



HAL
open science

ANAEROBIC DIGESTION OF VINASSE AND CFD MODELLING APPROACH CONTEXT AND OBJECTIVES OF THE WORK

Hélène Caillet, Alain Bastide, Graziella Chuppa-Tostain, Thomas Petit,
Laetitia Adelard

► **To cite this version:**

Hélène Caillet, Alain Bastide, Graziella Chuppa-Tostain, Thomas Petit, Laetitia Adelard. ANAEROBIC DIGESTION OF VINASSE AND CFD MODELLING APPROACH CONTEXT AND OBJECTIVES OF THE WORK. WasteEng 2018, Jul 2018, Prague, Czech Republic. hal-01857314

HAL Id: hal-01857314

<https://hal.science/hal-01857314v1>

Submitted on 15 Aug 2018

HAL is a multi-disciplinary open access archive for the deposit and dissemination of scientific research documents, whether they are published or not. The documents may come from teaching and research institutions in France or abroad, or from public or private research centers.

L'archive ouverte pluridisciplinaire **HAL**, est destinée au dépôt et à la diffusion de documents scientifiques de niveau recherche, publiés ou non, émanant des établissements d'enseignement et de recherche français ou étrangers, des laboratoires publics ou privés.

ANAEROBIC DIGESTION OF VINASSE AND CFD MODELLING APPROACH

Hélène Caillet¹ (helene.Caillet@univ-reunion.fr), Alain Bastide¹ (alain.bastide@univ-reunion.fr), Graziella Chuppa² (graziella.tostain@qualitropic.fr), Thomas Petit^{1,2} (Thomas.petit@univ-reunion.fr), Laetitia Adelard¹ (laetitia.adelard@univ-reunion.fr).

¹PIMENT Laboratory, Saint-Denis, Reunion Island, France
²LCSNSA Laboratory, Sainte-Denis, Reunion Island, France

CONTEXT AND OBJECTIVES OF THE WORK

- CHARACTERISATION of the substrates with the PHYSICO-CHEMICAL and RHEOLOGICAL properties ;
- MODELLING and OPTIMISATION of WET and DRY anaerobic digestion ;
- CFD MODELLING of the fluids flow with the LARGE-EDDY SIMULATIONS (LES) approach with Boussinesq approximation ;
- Development of 3D SINGLE-PHASE model considering MECHANICAL AGITATION ;

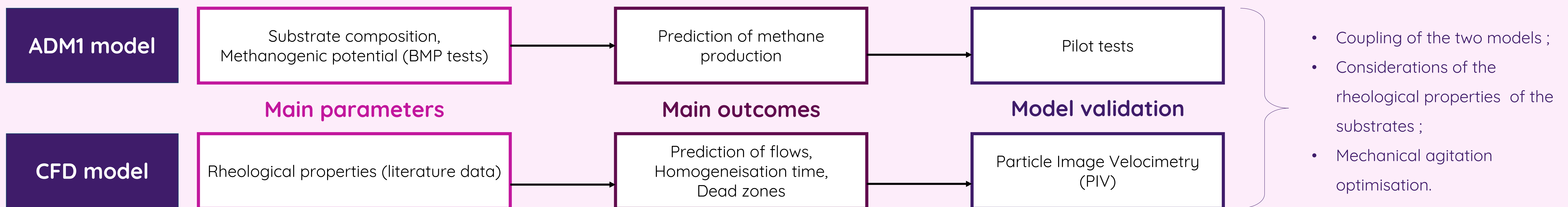

MATERIALS AND METHODS

EXPERIMENTATIONS:



Figure 1: Pilot (10L)

Physico-chemical tests:

- Hack Lange tests are used for the chemical oxygen demand (COD), the total carbon organic (TOC), the ammonium, the alkalinity and the Kjeldahl azote ;
- BMP tests in triplicate with blanks and positives ;
- I/S ratio of BMP: 2 ;
- Mesophilic digestion (37°C) ;

Pilot test:

- Mesophilic digestion ;
- Working volume: 7 L ;
- Volume added during digestion due to medium analysis: 1.6 L ;
- Initial pH: 7.29.

LITERATURE REVIEW OF PHYSICAL PROPERTIES:

- The vinasse is Newtonian ;
- The sludge is non-Newtonian and modelled with the Power-Law;
- The physical properties of liquid manure are used for the physical characterisation of sludge ;
- Studies have shown that the viscosity and shear stress increase exponentially as total solid (TS) increases.

Table 1: Physical parameters of Newtonian fluids

Fluid	Density kg.m ⁻³	Dynamic viscosity Pa.s
Vinasse	1044.69	0.001 009 7
Sludge	999.66	0.065

Table 2: Physical parameters of sewage sludges in pseudo-plastic model

TS %	T °C	k Pa.s ⁿ	n	Density kg.m ⁻³	η _{min} Pa.s	η _{max} Pa.s	γ̇ s ⁻¹	C _p J.kg ⁻¹ .°C ⁻¹	λ W.m ⁻¹ .°C ⁻¹
2.5	35	0.042	0.710	1000.36	0.006	0.008	4186.78	4186.78	0.6171
5.4	35	0.103	0.639	1000.72	0.009	0.025	50-702	4185.94	0.6169
7.5	35	0.525	0.533	1001.00	0.03	0.17	11-399	4185.33	0.6168
9.1	35	1.052	0.467	1001.31	0.07	0.29	11-156	4184.87	0.6167
12.1	35	5.885	0.367	1001.73	0.25	2.93	3-149	4184.00	0.6165
15	17-24	31.3	0.30	973.0	3.35	44.24	0.61-24.37	4183.17	0.6163
20	17-24	35.4	0.29	1091.8	3.69	48.6	0.64-24.14	4181.72	0.6159

Temperature (T), consistency coefficient (k), power-law index (n), viscosity (η), shear rate (γ̇), specific heat (C_p), thermal conductivity (λ).

CFD MODELLING:

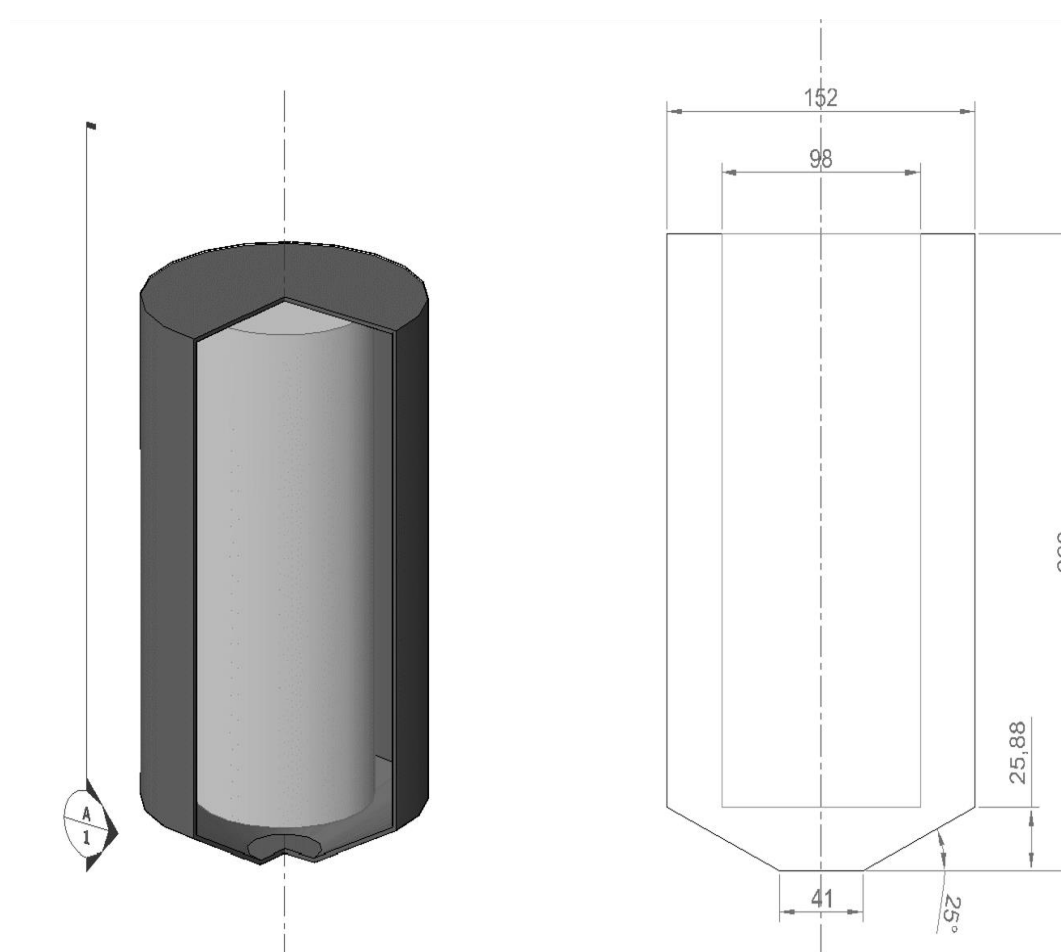

Figure 2: Digester geometry (mm)

We use the same geometry of Wu (2012). The internal cylinder is the sliding zone which contains the impeller.

- Mass and momentum conservation equations:

$$\frac{\partial \bar{u}_i}{\partial x_i} = 0 \quad \frac{\partial (\rho \bar{u}_i)}{\partial t} + \frac{\partial (\rho \bar{u}_i \bar{u}_j)}{\partial x_j} = -\frac{\partial \bar{P}}{\partial x_i} + \frac{\partial (\sigma_{ij})}{\partial x_j} - \frac{\partial \tau_{ij}}{\partial x_j} + g \beta \bar{\theta} e_z$$

- Heat transfer equation:
- SGS stress tensor:

$$\frac{\partial \bar{\theta}}{\partial t} + \bar{u}_r \cdot \frac{\partial \bar{\theta}}{\partial x_i} = \frac{\partial^2 D_r \bar{\theta}}{\partial x_j \partial x_j}$$

$$\tau_{ij} = -2\mu_s \bar{S}_{ij}$$

- Dynamic Lagrangian turbulence model.
- Pseudo-plastic model:

$$\tau = k \dot{\gamma}^n \quad \eta = k \dot{\gamma}^{n-1}$$

Velocity (u), fluid density (ρ), pressure (P), gravity (g), thermal expansion coefficient (β), temperature (θ), thermal diffusion coefficient (D_r), turbulent viscosity (μ_s), strain rate (S_{ij}).

RESULTS, DISCUSSIONS AND EXPECTED RESULTS

EXPERIMENTATION RESULTS:

Substrates	Total solid %	Volatile solid %	pH	COD g _{O2} .L ⁻¹	TOC mg.L ⁻¹	Ammonium mg.L ⁻¹	Alkalinity mg.L ⁻¹ .CaCO ₃	Kjeldahl nitrogen mg.L ⁻¹
Sewage sludge	2.2480	0.9700	4.84	9.93	-	517.67	-	-
Vinasse	6.6391	4.0378	7.57	79.67	27646.11	239.00	3651.25	1815.00

Table 3: Physico-chemical characteristics

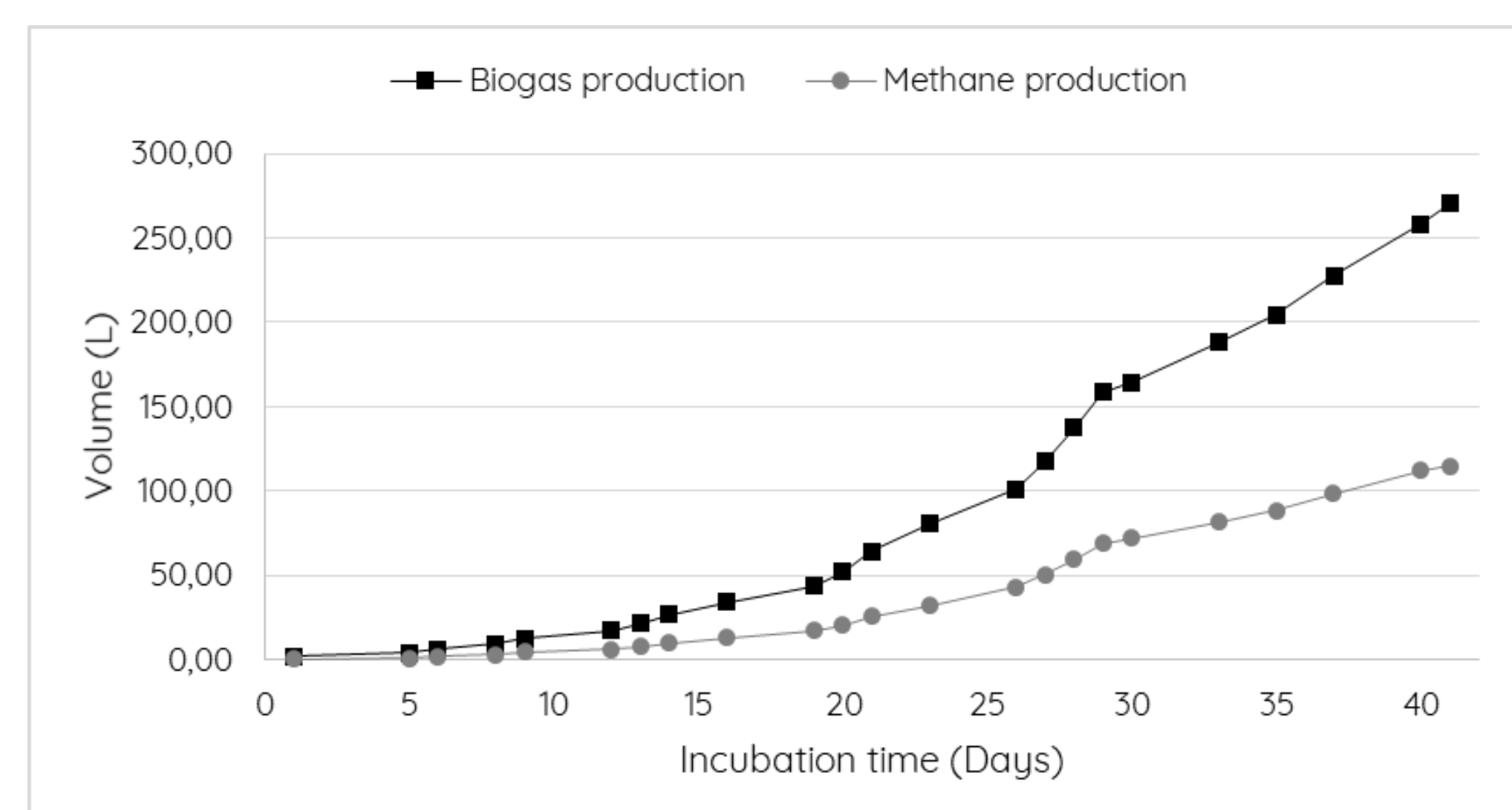
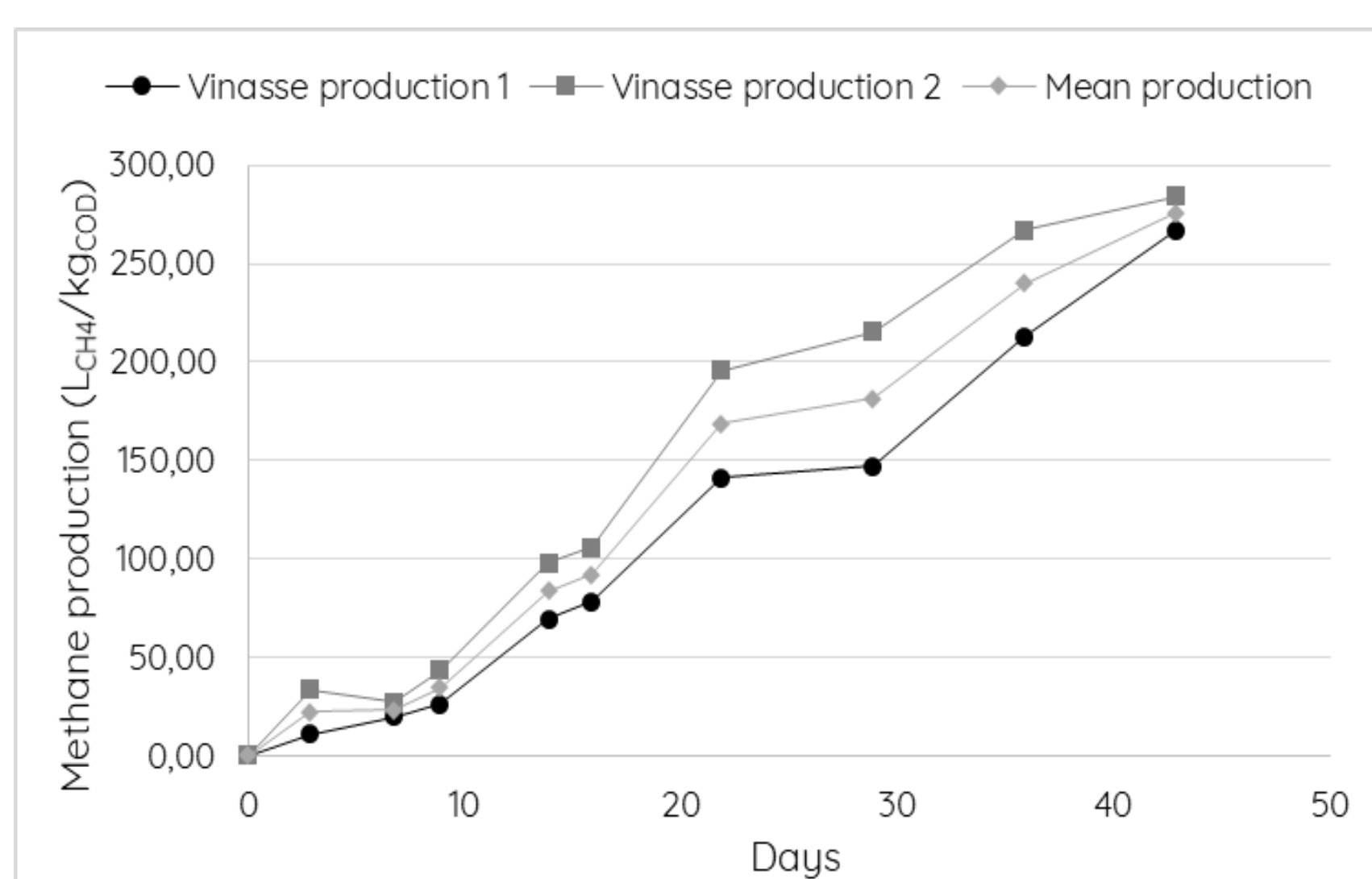

Figure 3: Cumulative methane production average as a function of time of vinasse in BMP (left) and pilot (right) tests

EXPERIMENTATION DISCUSSIONS:

- C/N ratio: 15.23
- Beyond 45 days to reach maximum methane production ;
- The vinasse is a complex substrate ;
- Vinasse methanogenic potential: 284.29 L_{CH4}.kg_{DCO}⁻¹ ;
- Pilot biogas production: 270.22 L_{Biogas} ;
- Pilot methane production: 114.64 L_{CH4}.

EXPECTED MODEL RESULTS:

- Validation of the CFD model ;
- The 3D single-phase simulations provide:
 - The velocities profiles ;
 - The temperature field ;
 - The power and the flow numbers ;
- Study of the dead zones (volume and position) and the homogenisation of the digestion medium.

CONCLUSION AND PERSPECTIVES

- Carry out CO-DIGESTION experimentations ;
- Carry out PILOT tests at different TS rates ;
- Develop MULTIPHASE model to predict the SPREAD OF MICROORGANISMS ;
- COUPLING of the CFD model to the ADM1 model ;
- OPTIMISATION of the MECHANICAL STIRRING of the process depending on the PHYSICAL PROPERTIES of the digestion medium.

REFERENCES

- B. Wu, "Large eddy simulation of mechanical mixing in anaerobic digesters," *Biotechnol. Bioeng.*, vol. 109, no. 3, pp. 804-812, Mar. 2012.
- C. Holliger et al., "Towards a standardization of biomethane potential tests," *Water Sci. Technol.*, vol. 74, no. 11, pp. 2515-2522, Dec. 2016.
- H. Landry, C. Laguë, and M. Roberge, "Physical and rheological properties of manure products," *Appl. Eng. Agric.*, vol. 20, no. 3, p. 277, 2004.
- V. A. Vavilin and I. Angelidaki, "Anaerobic degradation of solid material: Importance of initiation centers for methanogenesis, mixing intensity, and 2D distributed model," *Biotechnol. Bioeng.*, vol. 89, no. 1, pp. 113-122, Jan. 2005.