



HAL
open science

Fatigue crack growth in thin notched woven glass composites under tensile loading. Part I: experimental

Matthieu Bizeul, Christophe Bouvet, Jean-Jacques Barrau, Rémy Cuenca

► **To cite this version:**

Matthieu Bizeul, Christophe Bouvet, Jean-Jacques Barrau, Rémy Cuenca. Fatigue crack growth in thin notched woven glass composites under tensile loading. Part I: experimental. *Composites Science and Technology*, 2011, 71 (3), pp.289-296. 10.1016/j.compscitech.2010.11.019 . hal-01852900

HAL Id: hal-01852900

<https://hal.science/hal-01852900>

Submitted on 2 Aug 2018

HAL is a multi-disciplinary open access archive for the deposit and dissemination of scientific research documents, whether they are published or not. The documents may come from teaching and research institutions in France or abroad, or from public or private research centers.

L'archive ouverte pluridisciplinaire **HAL**, est destinée au dépôt et à la diffusion de documents scientifiques de niveau recherche, publiés ou non, émanant des établissements d'enseignement et de recherche français ou étrangers, des laboratoires publics ou privés.



Open Archive Toulouse Archive Ouverte (OATAO)

OATAO is an open access repository that collects the work of Toulouse researchers and makes it freely available over the web where possible.

This is an author -deposited version published in: <http://oatao.univ-toulouse.fr/>
Eprints ID: 4615

To link to this article: DOI:10.1016/j.compscitech.2010.11.019

URL: <http://dx.doi.org/10.1016/j.compscitech.2010.11.019>

To cite this version: BIZEUL Matthieu, BOUVET Christophe, BARRAU Jean-Jacques, CUENCA Rémy. Fatigue crack growth in thin notched woven glass composites under tensile loading. Part I: experimental. *Composites Science and Technology*, 2011, vol. 71, n° 3, pp. 289-296.
ISSN 0266-3538

Any correspondence concerning this service should be sent to the repository administrator:
staff-oatao@inp-toulouse.fr

Fatigue crack growth in thin notched woven glass composites under tensile loading. Part I: Experimental

M. Bizeul^a, C. Bouvet^{a,*}, J.J. Barrau^a, R. Cuenca^b

^a Université de Toulouse, INSA, UPS, Mines Albi, ISAE, Institut Clément Ader, 10 av. E. Belin F-31077 Toulouse, France

^b Eurocopter, 13725 Marignane, France

A B S T R A C T

Helicopter blades are made of composite materials mainly loaded in fatigue and have normally relatively thin skins. A through-the-thickness crack could appear in these skins. The aim of this study is to characterize the through-the-thickness crack propagation due to fatigue in thin woven glass fabric laminates. A technological test specimen is developed to get closer to the real loading conditions acting on these structures. An experimental campaign is undertaken which allows evaluating crack growth rates in several laminates. The crack path is linked through microscopic investigations to specify damage in woven plies. Crack initiation duration influence on experimental results is also underlined.

Keywords:

A. Structural composites

A. Glass fibres

B. Fatigue

B. Fracture

1. Introduction

Woven composites are advanced materials that are commonly used in aerospace applications. Their use is interesting owing to their excellent drapability over complex geometries, their effective manufacturing cost and their good damage tolerance properties.

For example, the skin of helicopter blades is often made of a few woven plies (Fig. 1). In these thin structure parts, a through-the-thickness crack might appear in service; such a crack could initiate and propagate from existing defects caused by manufacturing processes, stress concentration or low-energy impact [1]. In order to anticipate such a scenario which could slightly modify the rotor dynamic behaviour, it seems useful to study the crack propagation in these skins in fatigue. Blade loads are mainly defined by centrifugal forces and flap and drag bending moments due to cyclic aerodynamic loads. These structures are therefore subjected to fatigue stresses where the primary load is tension due to centrifugal effects.

Few studies are available related to fatigue crack propagation in woven laminates. Mandell [2] studied the propagation of a through-the-thickness crack in notched specimens loaded in tension-tension fatigue ($R = 0.1$, $f = 4-7$ Hz). Laminates were made of polyester resin and glass woven plies lined up with the load direction. The thickness was about 2.5 mm and the initial notch was cut with a 0.63 mm thickness diamond saw. The main characteristic underlined was that the crack growth was linked to fibre tow

width. Moreover, difficulty was encountered in measuring the crack length because of the stepwise nature of the crack growth and the extensive damage region associated with the crack tip. More recently, Shindo et al. [3] examined the mode I fatigue behaviour of notched plain woven glass laminates. For all specimens, the weft fibre bundles were aligned with the load axis. Load control fatigue tests were performed on CT specimens of thickness 25 mm. Crack lengths were calculated from the compliance data obtained during test using finite element analysis. Three stages of fatigue crack growth were identified: crack initiation, stable crack growth and unstable crack propagation. Optical micrograph of fatigue crack path taken at approximately $N/N_f = 90\%$ showed an amount of damage near the crack tip. The damage zone consisted especially of matrix cracks in the fibre bundle undulation region. Furthermore, the size scale of damage that occurred around the crack tip was not negligible compared to the other significant dimensions. Pegoretti and Ricco [4] investigated fatigue crack growth in polypropylene composites reinforced with short glass fibres. Experiments were conducted on a single-edge notched tension specimen of width 27 mm and of thickness 2.7 mm at room temperature: the notch length measured was 3 mm. The crack growth rate level was found to decrease as the fibre weight fraction increased. A further analysis of the data indicated that crack propagation was also governed by viscoelastic creep. Other works merely focused on the experimental determination of the fracture toughness of thin quasi-isotropic laminates made of glass woven plies in single edge notch (SEN) or center notch (CNT) specimens loaded in tension [5,6]. Constant values of fracture toughness are found for different crack lengths.

* Corresponding author.

E-mail address: christophe.bouvet@isae.fr (C. Bouvet).

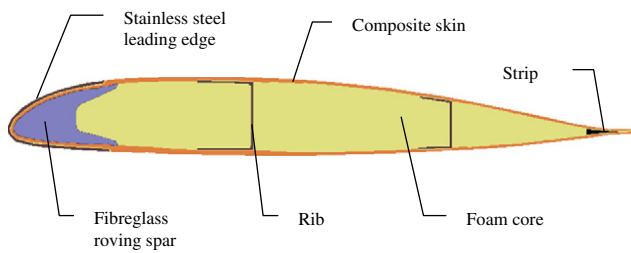

Fig. 1. Typical helicopter blade section.

The objective of this present paper is to study the tension–tension fatigue propagation of a through-the-thickness crack in notched laminates made of few woven glass plies. Several laminate stacking sequences are used for skin blades but some directions are commonly used. Thus, three simple stacking sequences are considered:

- An orthotropic laminate $[0]_2$ with two glass woven plies lined up with the tensile load. The influence of the tows nature (warp or weft) of the woven ply on the crack growth is supplemented. The fibre fatigue behaviour influence on the crack growth is then evaluated. In this paper, the laminate with the warp yarns of woven plies in the tensile direction is noted $[0^\circ]_2$ and actually presents 50% of fibres in 0° and in 90° directions; similarly, the laminate with the weft yarns in the tensile direction will be noted $[90^\circ]_2$ and presents 50% of fibres in 0° and in 90° directions.
- A bias laminate $[45]_2$. This laminate exhibits an important non-linear behaviour in tension. In this regard, the influence of matrix fatigue behaviour on the crack growth is assessed. It can be noted that this laminate presents the warp yarns in 45° direction and the weft ones in -45° direction, and in fact presents 50% of fibres in 45° and in -45° directions.
- A “quasi-isotropic” laminate $[45; 0; 45]$ with a middle woven ply having warp fibres in the load direction. This one may present coupled phenomena of the two previous laminates. Basically, this laminate is not quasi-isotropic, because quasi-isotropic needs the same number of plies in each direction, but this term is still used in the text below in order to simplify notations and is in quotes to avoid confusion.

2. Fatigue test specimen

The crack propagation is studied in glass/epoxy woven composite. These laminates are made of 8-harness satin balanced woven fabric (8-HS) pre-pegged plies with a fibre volume fraction of 50%. The yarn size is 0.5 mm-width and 0.1 mm-thickness. The elastic modulus are 21.5 and 20.5 GPa, the limit strength 385 and 280 MPa, respectively in the warp and weft directions, the shear modulus is 3.5 GPa and the shear strength 65 MPa. The samples are always manufactured with the warp woven face on the top of the thickness, so the top face is a warp side and the underside face a weft one.

In analyzing a typical blade section (Fig. 1), it can be stated that the skin has to follow the longitudinal strain of the spar mainly loaded by centrifugal effect. This remark leads to the development of a technological fatigue test specimen (Fig. 2) having a width 50 mm. A severe notch is performed on one edge with a 0.2 mm diameter diamond thread to limit the through-the-thickness crack initiation duration. On the other edge, a strip of T300/914 unidirectional carbon fibres having a stacking sequence of $[0]_2$ is placed to get closer to the real loading conditions and plays the role of spar. It also reduces the likelihood of global inelastic strains occurring

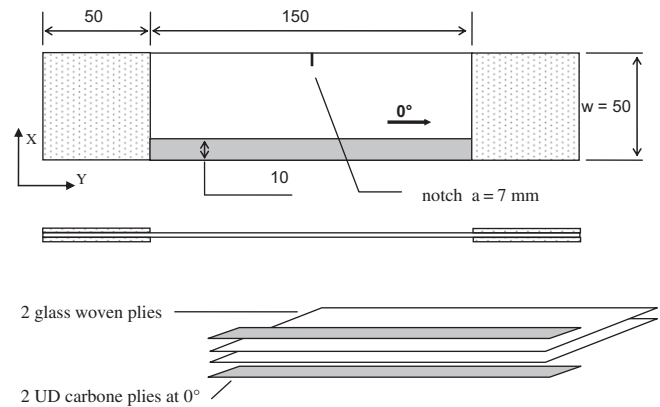

Fig. 2. Fatigue specimen test characteristics.

under fatigue loading. The fatigue tests are conducted under strain control at room temperature (about 20°C) on a 100 kN closed-loop servo-hydraulic Instron tension machine, with an extensometer placed on the carbon strip, at a frequency of 20 Hz. The imposed strain levels are $\epsilon_{\min} = 10^{-3}$ and $\epsilon_{\max} = 3 \times 10^{-3}$. This maximum fatigue strain level corresponds to the infinite life asymptote in $S-N$ curve [7–11] and is widely used as design fatigue strain for structures made of glass plies. The specimen is cooled down to room temperature by a fan and its temperature is saved (the thermocouple sensor is located 10 mm under the notch). Furthermore, no increase in temperature was recorded.

The crack growth is monitored with the help of a CCD camera (Fig. 3). The different devices are driven with the help of a Labview program. Due to the relative transparency of the glass fibres reinforced plastics, the propagation of a white damage zone by back-illumination is observed. This kind of phenomenon was also described by [5,9]. In a previous work [12], this damage zone was identified as a through-the-thickness crack all along by microscopic investigations. Since the beginning of the crack growth, this damage zone has presented tows breakage even in the tip. This damage zone also contains transverse yarn cracking and meta-delaminations [13].

3. Fatigue crack growth results

3.1. Warp and weft direction

Earlier experiments [12] showed a different behaviour between warp and weft directions of the studied balanced woven ply under static loading as well as in fatigue, especially in crack propagation tests in samples of 30 mm width (Fig. 4). The main fact underlined by these results is the large dispersion between samples in both cases, either for the laminates with warp tows coinciding with load direction, or for the weft ones. It can be noted on this figure, the six warp and weft samples are exactly the same, only the initial crack tip position relative to the yarns should be different (this manufacturing parameter is difficult to control). These differences have been connected to the crack initiation time [12] which depends on the solicitation direction and on the initial crack tip position relative to the yarns position. In fact, more the initiation time is long, more the crack growth decreases because of the extended of the damage zone. This fact may be due to the small number of plies [14] and perhaps because the experiments are led in strain controlled. Moreover, the crack growth initiation duration in warp laminates was lower than in weft laminates. As the weft direction undulation is more severe, the matrix damage in this direction appears sooner. So, the initiation phase lasts more and the crack growth rate decreases because of the extended damage zone.

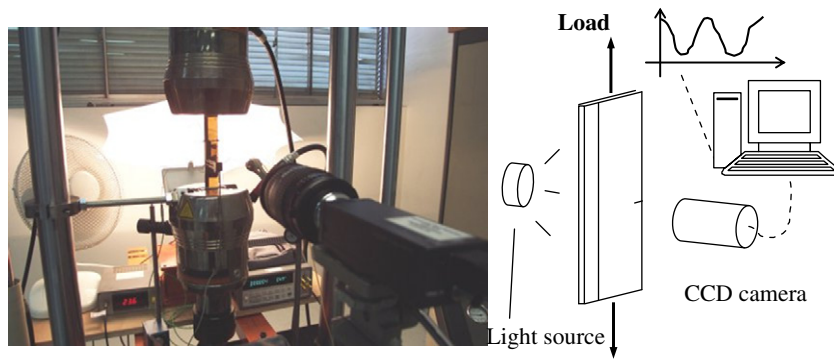

Fig. 3. General and schematic views of the experiment setup.

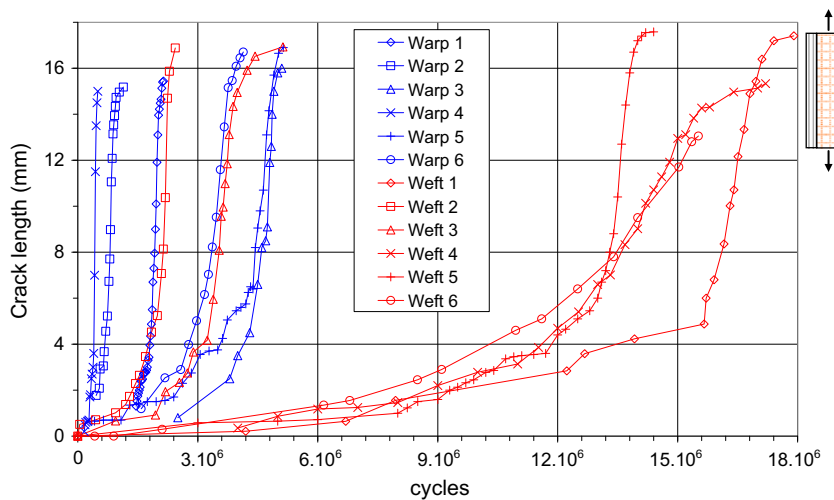

Fig. 4. Fatigue crack growth in warp $[0]_2$ (a) and weft $[90]_2$ (b) laminates in samples of 30 mm width.

In order to study the crack growth in a larger domain and to reduce the mean initiation duration, the geometric characteristics of the specimen have been modified (Fig. 2): The ratio a/w has been increased in order to limit the initiation duration and the specimen width is larger.

The crack growth in 50 mm width samples exhibits qualitative similarity (Fig. 5). It can be noted, on this figure, the three warp and the two weft samples are exactly the same, only the initial crack

position relative to the yarns should be different. Three stages are easily noticed: the first two are commonly observed [3,4]: the “initiation” phase where crack length does not exceed 3 mm and the “stable propagation” phase. The last one corresponds to the crack arrest due to the carbon strip influence.

Actually, two main observations are noteworthy. First, the different behaviour between warp and weft directions in crack propagation does not subsist, as the crack growths are similar and even

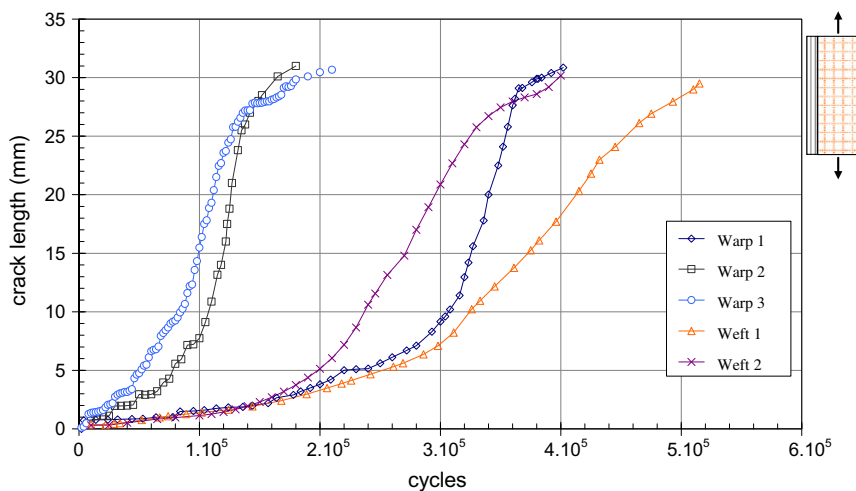

Fig. 5. Fatigue crack growth in warp $[0]_2$ and weft $[90]_2$ laminates in samples of 50 mm width.

overlap for two warp and weft samples. The second point is about the crack propagation test duration. This period of time is divided by around 10 compared to the previous geometry where the specimens' width was equal to 30 mm. Moreover, as the crack initiation duration does not vary as much as the one corresponding to 30 mm width specimens, the crack growth rates are of the same order (Table 1). Table 1 recalls the extreme results of crack growth in 30 mm width samples of the previous experimental campaign and specifies key results of crack growth in the 50 mm width samples. The initiation duration is determined owing to the typical decrease of crack growth rate at the beginning of the propagation (Fig. 6). This phenomenon is associated with the microstructure influence on crack growth [3,4]. Bizeul et al. [12] stated that crack growth evolves regularly when three to five tows are broken. In other words, as the yarn width is equal to 0.5 mm, microstructure influence seems to exist when the crack length is less than 3 mm.

The microstructure of the studied woven ply acts not only on the initiation duration but also on the crack path. It is interesting to examine the local crack path in relation to the woven scheme (Fig. 7). The warp side of the woven ply is observed on the photograph; the warp tows are then visible on the surface and lined up with the fatigue tensile load. The theoretical basic 8-harness satin weave pattern is shown next to the photograph. The crack path is overall straight but in focusing on the local crack path, it can be seen that the cross-over points of the woven plies are ideal places for fibre tow failure. The photograph also highlights that thin longitudinal matrix cracks are localized in the interstice between two consecutive tows and their lengths are limited by cross-over points.

These observations are in accordance with [5,8,10,15,16] where fatigue damage in the on-axis directions is initiated by cracks in transverse fibre yarn, and are deflected along the longitudinal yarn (meta-delamination) and finally leads to 0° tow fracture at crimp regions.

Additionally, from examination of the crack, it seems realistic to say that a tow of fibre always breaks entirely. This remark is consistent with the work of [17]. The crack extends in a discrete manner and is linked to tow width [2].

3.2. Bias direction

Usually, helicopter blade skins are mostly made of $\pm 45^\circ$ woven plies in order to ensure the torsional stiffness of the profile (Fig. 1). Thus, fatigue tests at controlled strain ratio are carried out on specific specimens (Fig. 2) with carbon strip on one edge in order to represent the blade spar and $\pm 45^\circ$ woven laminate elsewhere. The propagation of a white damage zone is monitored in particular test configurations detailed below. With the initial specimen (Fig. 2), the crack growth is very slow and even stops even in the case when the notch length is increased. A damage zone appears in the tip of the notch in a V-form (Fig. 8) and stays stationary. Owing to back-illumination, this zone appears in dark on the

photograph taken at the maximum fatigue strain level (5×10^6 cycles), which results in a through-the-thickness crack of less than 2 mm. It should be pointed out that matrix damage extends over the crack tip in the form of thin and straight matrix cracks between aligned tows.

The accumulation of matrix damage specific to $[\pm 45]_n$ laminates [18], tends to limit the stress concentration in the vicinity of the crack tip and basically the crack growth. Hence, changes are made on the specific specimen to improve the initiation and the propagation of a through-the-thickness crack in $[45]_2$ laminates while maintaining the fatigue strain levels previously fixed. In order to get closer to the complex service loading conditions of blade skins, the trailing edge strip influence has been taken into account (Fig. 1). This rear strip has many functions such as closing the torsion box of the profile, dragging a part of centrifugal load and adding trailing flexural stiffness to the blade. The fibres of this structural part are then aligned with the blade longitudinal axis like leading edge spar fibres. Yet, the initial specific specimen lacks longitudinal stiffness on the notch side and the main part of the tensile load goes on the other side in the carbon strip. A small part of the load is thus drained in the notch tip, slowing even the crack initiation. In order to observe a fatigue crack growth in these bias woven laminates, the technological specimen has been modified accordingly (Fig. 9). A similar UD carbon strip has been placed on the other edge of the sample, acting as a trailing edge spar. After polymerization and cutting a notch with a diamond thread, whose length is narrowly greater than the strip width.

The crack initiation is instantaneous with such a test configuration (Fig. 10), however the crack growth tends to slow down gradually. The fatigue tests show very similar results and have a duration of about 5×10^6 cycles. This may be attributed to the fact that in the beginning of the test, crack growth rate is high, the crack initiation duration remains thus low and relatively close to a specimen to another. Unlike oriented laminates, the initiation duration has negligible influence on crack growth.

After measuring the crack growth in fatigue, the crack growth rate is deduced and plotted versus crack growth for each sample (Fig. 11). In the beginning of the crack growth, its rate decreases and then reaches a steady state when crack length is between 10 and 20 mm. Finally, the crack growth tends to "stop" when the crack length measures 25 mm, corresponding to a distance of 8 mm from the carbon strip acting as a leading edge spar. Thus, inelastic strains are likely to occur in fatigue in $[45]_2$ laminates as reported by [8,19], especially in the vicinity of the crack tip. This phenomenon is due to the damage of the resin under shear solicitations and to the fibres rotations. As the fatigue tests are led in a strain control environment, the stress concentration in front of the crack is reduced with the appearance and development of inelastic strains. It seems that there is a threshold below which propagation cannot occur, as underlined by the fatigue tests on specimens without UD reinforcement corresponding to blade rear strip.

Table 1
Key results for fatigue crack growth in warp $[0]_2$ and weft $[90]_2$ laminates.

| | Notch length (mm) | Initiation duration (cycles) | Maximum recorded crack growth rate (mm/cy.) |
|---------------------------|-------------------|------------------------------|---|
| <i>Sample width 30 mm</i> | | | |
| Warp 5 | 2.9 | 1.3×10^6 | 2.6×10^{-5} |
| Warp 4 | 2.4 | 2.0×10^5 | 2.0×10^{-4} |
| Weft 4 | 2.8 | 11×10^6 | 4.0×10^{-6} |
| Weft 2 | 2.9 | 6×10^5 | 9.7×10^{-5} |
| <i>Sample width 50 mm</i> | | | |
| Warp 1 | 7.1 | 2.0×10^5 | 3.1×10^{-4} |
| Warp 2 | 6.9 | 6.5×10^4 | 5.0×10^{-4} |
| Warp 3 | 7.0 | 5.0×10^4 | 3.9×10^{-4} |
| Weft 1 | 6.9 | 2.4×10^5 | 2.6×10^{-4} |
| Weft 2 | 6.9 | 1.8×10^5 | 3.7×10^{-4} |

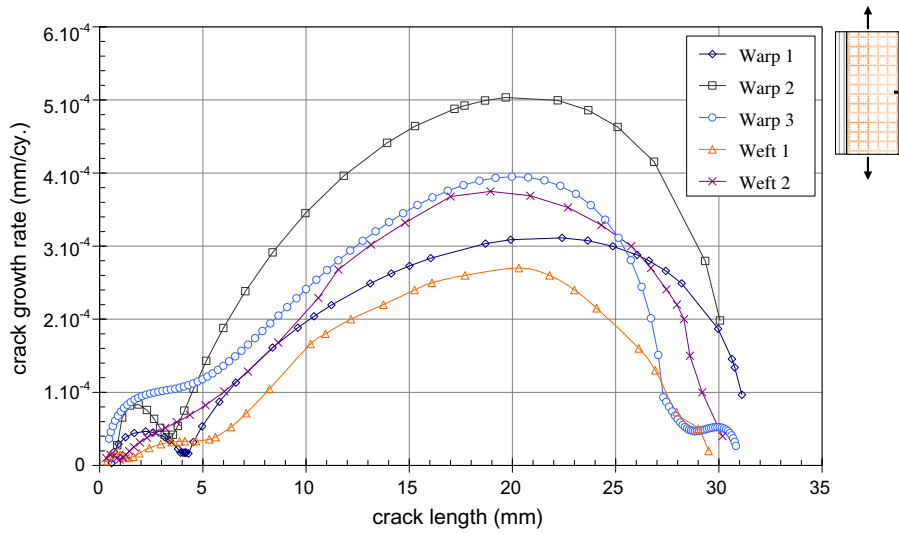

Fig. 6. Crack growth rates versus crack length in warp $[0]_2$ and weft $[90]_2$ laminates in samples of 50 mm width.

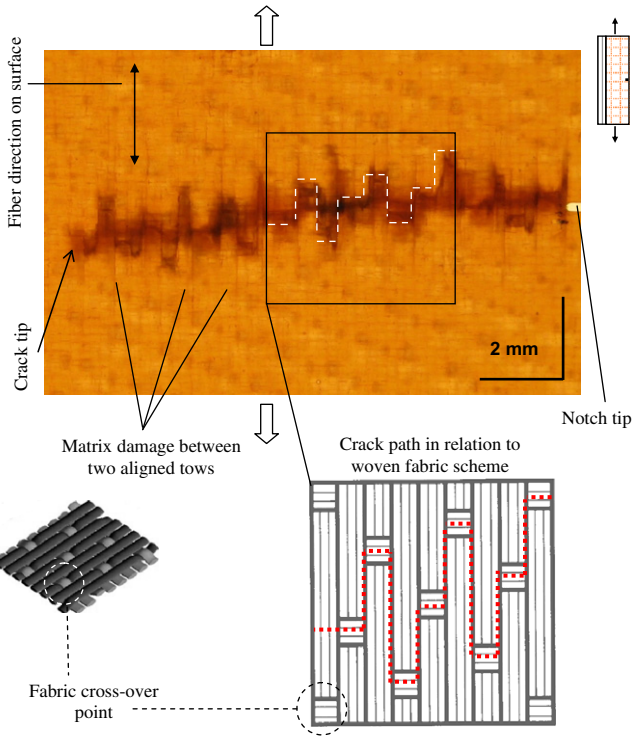

Fig. 7. Crack path in relation to woven fabric scheme in $[0]_2$ notched laminate loaded in fatigue.

The visible white damage zone which propagates corresponds to a through-the-thickness crack (Fig. 12). Tow breakage are easy to recognize in microscopic investigations if observations are carried out perpendicular to the fibres. Tow fracture mainly appear in the fibre undulation areas. Typical damages in woven ply also exist i.e., meta-delaminations, transverse microcracks, etc.

Again, optical analysis reveals that the local crack path in $[45]_2$ laminates is influenced by the weave pattern and the tow width (Fig. 12). As observed by Woo et al. [16], the through-the-thickness crack propagates perpendicular to yarn fibres and thus shifts alternately between $\pm 45^\circ$ directions. The entire crack path remains overall straight and perpendicular to the load direction. In addition,

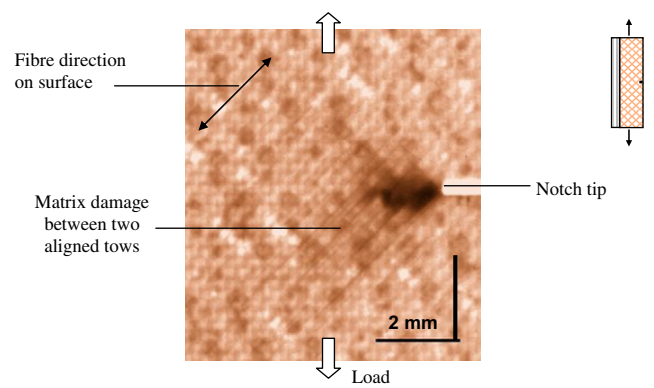

Fig. 8. Crack length after 5×10^6 cycles in $[45]_2$ notched laminate loaded in fatigue.

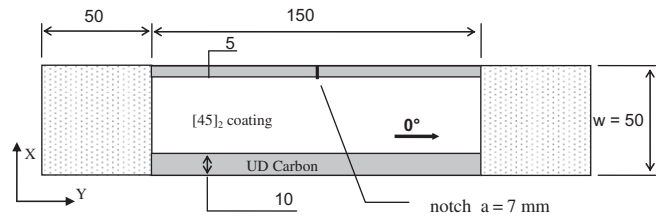

Fig. 9. Fatigue specimen test characteristics modified for $[45]_2$ laminates.

it is noticeable that the crack extends according to the fibre tow width and the tows always seem to break completely.

Once more the crack path has to go through the nearest cross-over points of the woven plies; yarn failures mainly occur in these crimp areas. Finally, it is interesting to note that matrix damage surround the crack path. These consist especially of thin and long matrix cracks parallel to the fibres. It seems appropriate to associate these observations with the matrix degradation in the gap that exists between two consecutive yarns. Only the thin cracks parallel to the fibres closest to the surface are visible. They form a halo around the crack which extends over a length around 2–3 mm in the direction of fibres on both sides. Damage in V-form is visible in the crack tip.

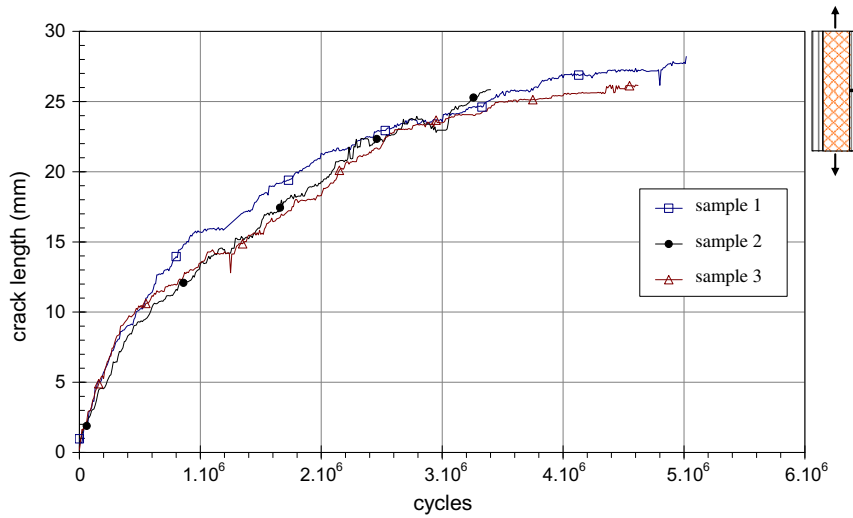

Fig. 10. Fatigue crack growth in $[45]_2$ laminates with two carbon strips.

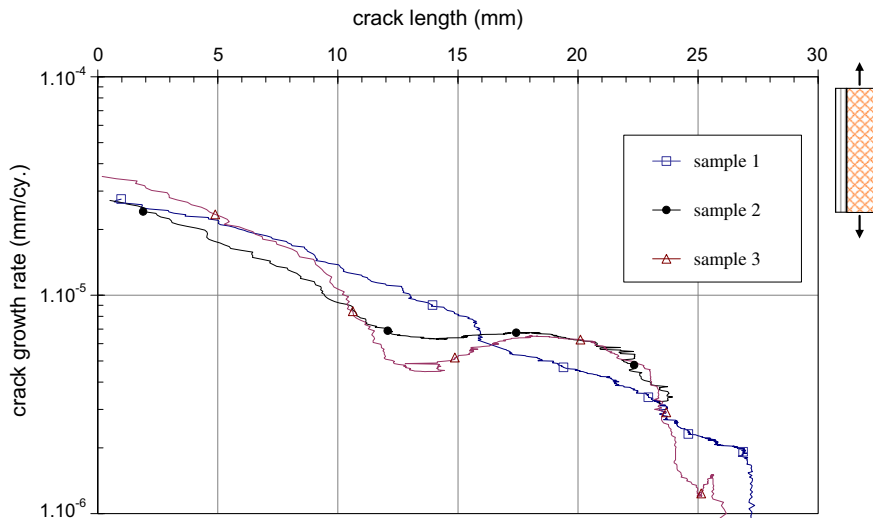

Fig. 11. Fatigue crack growth rate in $[45]_2$ laminates with two carbon strips.

3.3. “Quasi-isotropic” laminate

Stacking sequences of blades skins are mostly a combination of those simple ones previously studied. In accordance with this remark, the crack growth in $[45; 0; 45]$ “quasi-isotropic” laminates is investigated. The warp direction of the 0° woven ply corresponds to the loading direction. The specimen is similar to that used for the warp and weft campaign (Fig. 2) and thus presents a carbon strip on one edge. The other test characteristics are identical.

The crack growth in “quasi-isotropic” laminates follows the same three stages of the warp laminates i.e., the crack growth is very slow when the crack length remains less than 3 mm, then the crack growth rate increases until it reaches a maximum corresponding to a crack length of 20 mm and eventually decreases quickly (Fig. 13). The maximum crack growth rate levels are very close to those recorded in warp laminates. Nevertheless, it should be noted that the first stage of crack growth, usually called ‘initiation phase’, lasts a long time in comparison with the warp laminates one. The test duration is between 0.6×10^6 and 2.1×10^6 cycles and the ‘initiation phase’ corresponds to 70% of this period, while the test duration for warp laminates is four times lower and the first related stage is equal to 40% of this time.

These comparisons seem to show that the fatigue crack propagation in “quasi-isotropic” laminates amounts to crack growth in warp laminates whose initiation duration lasts a long time. Therefore, the layers at $\pm 45^\circ$ tend to slow the through-the-thickness crack initiation and its growth, at least until reaching a certain length. Then after this time period, the fatigue crack growth in “quasi-isotropic” laminates is similar to that found in the warp laminates. Marissen et al. [6] mentioned the same type of influence for $\pm 45^\circ$ plies in notched quasi-isotropic laminates.

4. Conclusions

Fatigue crack growth in thin woven glass laminates has been investigated in this research. A technological test specimen has been developed to get closer to the real loading conditions acting on helicopter blade skins. From the present experimental results, following conclusions can be drawn:

- in warp and weft laminates, the maximum crack growth rate level seems to be related to the crack initiation duration, namely when this duration increases the maximum rate decreases. As this time period does not vary for several samples,

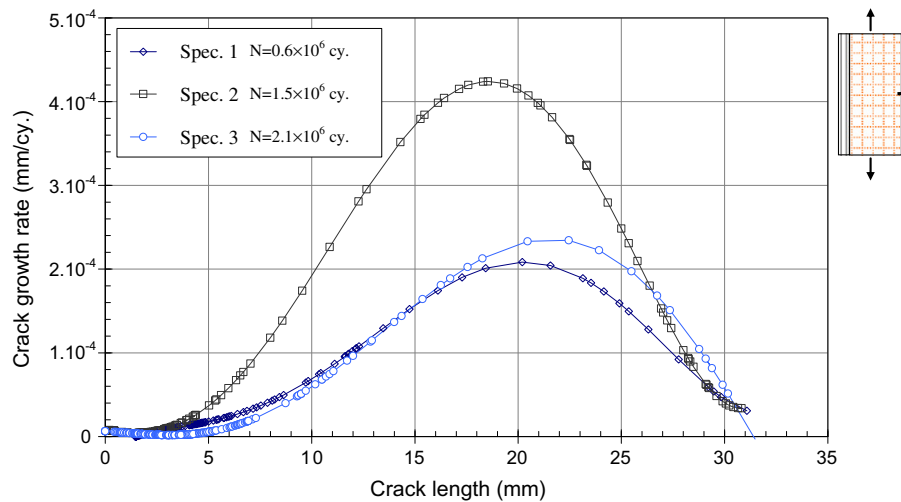

Fig. 13. Fatigue crack growth rate in [45; 0; 45] laminates.

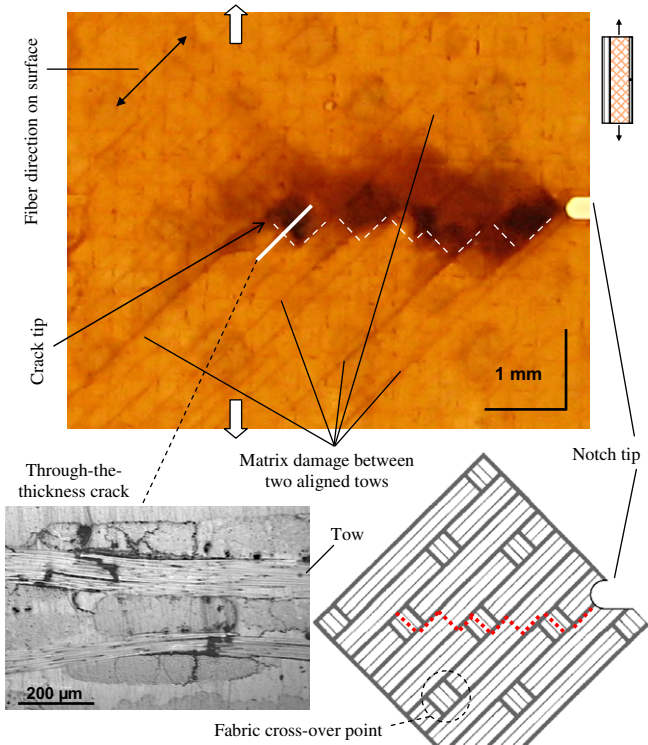

Fig. 12. Crack path in relation to woven fabric scheme in [45]₂ notched laminate loaded in fatigue.

the crack growth rate seems to be independent of the tow type (warp or weft). Nevertheless, weft laminates present longer crack initiation duration due to their earlier ability to matrix damage;

- in bias laminates, an amount of matrix damage avoids the crack initiation in front of the notch tip. This phenomenon leads to a modification of the technological test specimen in order to observe a crack growth;
- in "quasi-isotropic" laminates, the crack growth is similar to warp laminates qualitatively and quantitatively except the 'initiation phase' which lasts more. 45° woven plies seem to slow down the crack growth for crack lengths less than 3 mm;

- in each previous laminate, the microstructure influence is emphasized. The cross-over points of the woven ply are ideal places for fibres tow failure. Hence, the weave pattern influences the local crack path. Moreover, the crack propagates perpendicular to yarn fibres as the global crack path remains straight. It also seems that tow fibre always fails entirely. The through-the-thickness crack extends in a discrete manner and is linked to tow width. Typical matrix damage of woven ply also surrounds the crack path. On one hand it consists of meta-delaminations, while on the other hand, thin and long matrix cracks parallel to the fibres are located in the interstice between two consecutive tows, where their length is limited by cross-over points.

References

- [1] Hansen U. Damage development in woven fabric composites during tension-tension fatigue. *J Compos Mater* 1999;33(7).
- [2] Mandell JF. Fatigue crack propagation rates in woven and non woven fiber glass laminates. *Compos Rel ASTM STP* 1975;580:515-27.
- [3] Shindo Y, Inamoto A, Narita F. Characterization of Mode I fatigue crack growth in GFRP woven laminates at low temperatures. *Acta Mater* 2005;53:1389-96.
- [4] Pegoretti A, Ricco T. Fatigue crack propagation in polypropylene reinforced with short glass fibres. *Compos Sci Technol* 1999;59:1055-62.
- [5] Belmonte H, Manger C, Ogin S, Smith P, Lewin R. Characterisation and modelling of the notched tensile fracture of woven quasi-isotropic GFRP laminates. *Compos Sci Technol* 2001;61:585-97.
- [6] Marissen R, Westphal T, Sterk J. Fracture of quasi-isotropic composite sheets with sharp notches. *Compos Sci Technol* 2006;66:1803-12.
- [7] Shindo Y, Takano S, Horiguchi K, Sato T. Cryogenic fatigue behavior of plain weave glass/epoxy composite laminates under tension-tension cycling. *Cryogenics* 2006;46:794-8.
- [8] Pandita S, Huysmans G, Wevers M, Verpoest I. Tensile fatigue behaviour of glass plain-weave fabric composites in on - and off-axis directions. *Compos: Part A* 2001;32:1533-9.
- [9] Xiao J, Bathias C. Damage and fracture of notched non-woven and woven composites laminates. *Compos Sci Technol* 1994;52:99-108.
- [10] Fujii T, Amijima S. Microscopic fatigue processes in a plain-weave glass-fibre composite. *Compos Sci Technol* 1993;49:327-33.
- [11] Talreja R. Fatigue of composite materials: damage mechanisms and fatigue life diagrams. In: *Fatigue Compos Mater*. Lancaster, PA: Technomic; 1987.
- [12] Bizeul M, Bouvet C, Barrau JJ, Cuenca R. Influence of woven ply degradation on fatigue crack growth in thin notched composites under tensile loading. *Int J Fatigue* 2010;32:60-5.
- [13] Patel S, Case SW. Durability of a graphite/epoxy woven composite under combined hygrothermal conditions. *Int J Fatigue* 2000;22:809-20.
- [14] Boniface L, Ogin SL, Smith PA. Damage development in woven glass fibre/epoxy laminates under tensile loading. In: *Proc. 2nd int. conference deformation and fracture of composites*. UMIST, Manchester; 1993. p. 33-1-33-10.
- [15] Osada T, Asami N, Hiroyuki H. Initial fracture behaviour of satin woven fabric composites. *Compos Struct* 2003;61:333-9.
- [16] Woo SC, Choi NS. Analysis of fracture process in single-edge-notched laminated composites based on the high amplitude acoustic emission events. *Compos Sci Technol* 2007;67:1451-8.

- [17] Schulte K, Reese E, Chou T. Fatigue behaviour and damage development in woven fabric and hybrid fabric composites. In: Proceedings of the sixth international conference on composite materials (ICCM-VI) and second European conference on composite materials (ECCM-II), vol. 4. London, UK, 20-24 July; 1987.
- [18] Tong J. Characteristics of fatigue crack growth in GFRP laminates. *Int J Fatigue* 2002;24:291-7.
- [19] Hochard C, Payan J, Bordreuil C. A progressive first ply failure model for woven ply CFRP laminates under static and fatigue loads. *Int J Fatigue* 2006;28:1270-6.