



HAL
open science

New criteria for iterative decoding

Florence Alberge, Ziad Naja, Pierre Duhamel

► **To cite this version:**

Florence Alberge, Ziad Naja, Pierre Duhamel. New criteria for iterative decoding. ICASSP 2009 - 34th IEEE International Conference on Acoustics, Speech and Signal Processing, Apr 2009, Taipei, Taiwan. hal-01849643

HAL Id: hal-01849643

<https://hal.science/hal-01849643>

Submitted on 26 Jul 2018

HAL is a multi-disciplinary open access archive for the deposit and dissemination of scientific research documents, whether they are published or not. The documents may come from teaching and research institutions in France or abroad, or from public or private research centers.

L'archive ouverte pluridisciplinaire **HAL**, est destinée au dépôt et à la diffusion de documents scientifiques de niveau recherche, publiés ou non, émanant des établissements d'enseignement et de recherche français ou étrangers, des laboratoires publics ou privés.

New criteria for iterative decoding

Florence Alberge, Ziad Naja, Pierre Duhamel
International Conference on Acoustic Speech and Signal Processing 09

Univ. Paris-Sud, UMR 8506, Orsay
CNRS, Orsay, France

Laboratoire des Signaux et Systèmes
Supélec, Gif-sur-Yvette, France

Context: Turbo-like algorithms with iterative decoding

Goal: Make the link between iterative decoding and classical optimization techniques. Improve the performance of iterative decoding.

System model (Bit Interleaved Coded Modulation)(Zehavi, 1992; Li, 2002)

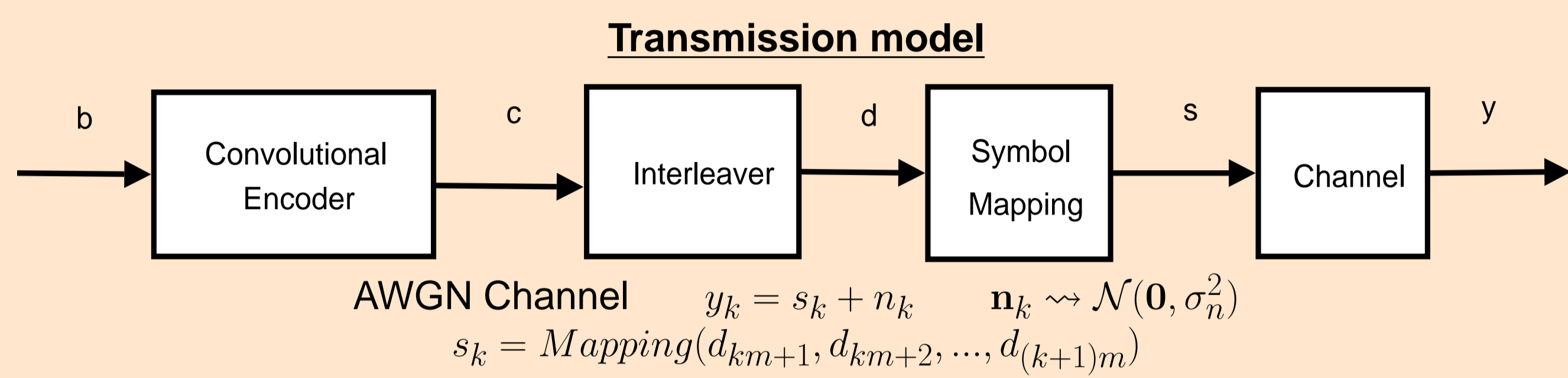

BICM-ID receiver with soft-decision feedback

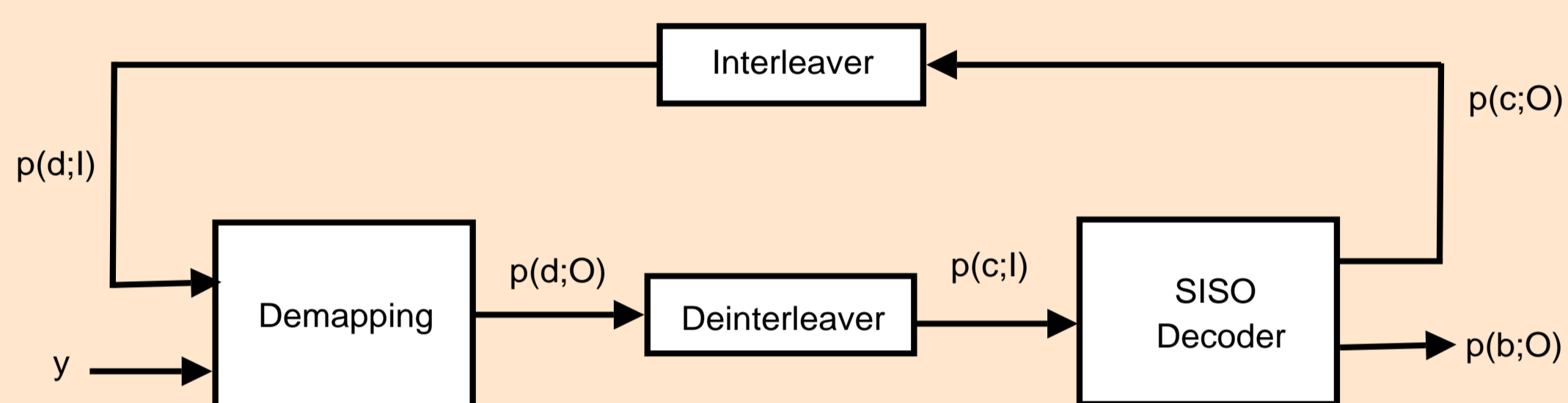

APP (Demapping) $p_{APP}(d_{km+i} = b) = K'_m \sum_{\mathbf{s}_k \in \Psi_b^i} p(\mathbf{y}_k | \mathbf{s}_k) \prod_j p(d_{km+j}; I)$

Prior \times Channel probability \rightarrow Marginalization

Extrinsic (Demapping) $p(d_{km+i} = b; O) = K_m \sum_{\mathbf{s}_k \in \Psi_b^i} p(\mathbf{y}_k | \mathbf{s}_k) \prod_{j \neq i} p(d_{km+j}; I)$

APP (Decoder) $p_{APP}(c_l = b) = K'_c \sum_{\mathbf{c} \in \mathcal{R}_b^l} \mathbf{I}_C(\mathbf{c}) \prod_j p(c_j; I)$ (\mathbf{I}_C indicator function of the code)

Prior \times Indicator function \rightarrow Marginalization

Extrinsic (Decoder) $p(c_l = b; O) = K_c \sum_{\mathbf{c} \in \mathcal{R}_b^l} \mathbf{I}_C(\mathbf{c}) \prod_{j \neq l} p(c_j; I)$

Information geometry and iterative decoding

Basic tools and Notations (Walsh, 2006)

$(\mathbf{B}_i) \in \{0, 1\}^N$ binary representation of integer i gathered into matrix $\mathbf{B} = (\mathbf{B}_0, \mathbf{B}_1, \dots, \mathbf{B}_{2^N-1})^T$.

PMF $\eta = (\Pr[\chi = \mathbf{B}_0], \Pr[\chi = \mathbf{B}_1], \dots, \Pr[\chi = \mathbf{B}_{2^N-1}])^T$

Log-coordinates of PMF η $(\theta_i)_{0 \leq i \leq 2^N-1} = \ln(\Pr[\chi = \mathbf{B}_i]) - \ln(\Pr[\chi = \mathbf{B}_0])$

Bitwise log-probability ratio $(\lambda_j)_{0 \leq j \leq N-1} = \log\left(\frac{\Pr[\chi_j=1]}{\Pr[\chi_j=0]}\right)$

For factorisable probability measures, the log-coordinates take the form $\theta = \mathbf{B}\lambda$.

Link with iterative decoding

Demapping sub-block

$$p_{APP}(d_{km+i} = b) = K'_m \sum_{\mathbf{s}_k \in \Psi_b^i} p(\mathbf{y}_k | \mathbf{s}_k) \prod_j p(d_{km+j}; I)$$

\downarrow θ_m \downarrow Log-coordinates $\mathbf{B}\lambda_1$

$$p_{APP}(d_{km+i} = b) = K''_m p(d_{km+i}; I) p(d_{km+i}; O)$$

\downarrow $\mathbf{B}\lambda_1$ \downarrow Log-coordinates $\mathbf{B}\lambda_2$

The demapping sub-block solves, with respect to λ_2 , $p_{\mathbf{B}(\lambda_1+\lambda_2)} = p_{\mathbf{B}\lambda_1+\theta_m}$

Decoding sub-block

$$p_{APP}(c_l = b) = K'_c \sum_{\mathbf{c} \in \mathcal{R}_b^l} \mathbf{I}_C(\mathbf{c}) \prod_j p(c_j; I)$$

\downarrow θ_c \downarrow Log-coordinates $\mathbf{B}\lambda_2$

$$p_{APP}(c_l) = K''_c p(c_l; I) p(c_l; O)$$

\downarrow $\mathbf{B}\lambda_2$ \downarrow Log-coordinates $\mathbf{B}\lambda_1$

The decoding sub-block solves, with respect to λ_1 , $p_{\mathbf{B}(\lambda_1+\lambda_2)} = p_{\mathbf{B}\lambda_2+\theta_c}$

Global criterion

Let $D_{FD}(\mathbf{p}, \mathbf{q}) = \sum_j p_j \ln\left(\frac{p_j}{q_j}\right) + \sum_j (1-p_j) \ln\left(\frac{1-p_j}{1-q_j}\right)$ denote the Fermi-Dirac entropy (Kullback-Leibler distance for bit probabilities).

The demapping sub-block solves the minimization problem $\min_{\lambda_2} D_{FD}(p_{\mathbf{B}\lambda_1+\theta_m}, p_{\mathbf{B}(\lambda_1+\lambda_2)})$.

The decoding sub-block solves the minimization problem $\min_{\lambda_1} D_{FD}(p_{\mathbf{B}\lambda_2+\theta_c}, p_{\mathbf{B}(\lambda_1+\lambda_2)})$.

New criteria

An hybrid proximal point algorithm

Goal: Link the two (independent) criteria using proximal point technique (Luque, 1984).

Demapping $\min_{\lambda_2} J_{\theta_m}(\lambda_1, \lambda_2) = \min_{\lambda_2} D_{FD}(p_{\mathbf{B}\lambda_1+\theta_m}, p_{\mathbf{B}(\lambda_1+\lambda_2)}) + \mu_m D_{FD}(p_{\mathbf{B}(\lambda_1^{(k)}+\lambda_2^{(k)})}, p_{\mathbf{B}(\lambda_1+\lambda_2)})$

Decoding $\min_{\lambda_1} J_{\theta_c}(\lambda_1, \lambda_2) = \min_{\lambda_1} D_{FD}(p_{\mathbf{B}\lambda_2+\theta_c}, p_{\mathbf{B}(\lambda_1+\lambda_2)}) + \mu_c D_{FD}(p_{\mathbf{B}(\lambda_1^{(k)}+\lambda_2^{(k+1)})}, p_{\mathbf{B}(\lambda_1+\lambda_2)})$

Optimal choice of the step-size :

Choose μ_m such that $J_{\theta_m}(\lambda_1^{(k)}, \lambda_2^{(k+1)}) \leq J_{\theta_m}(\lambda_1^{(k)}, \lambda_2^{(k)})$
 Choose μ_c such that $J_{\theta_c}(\lambda_1^{(k+1)}, \lambda_2^{(k+1)}) \leq J_{\theta_c}(\lambda_1^{(k)}, \lambda_2^{(k+1)})$

Both criteria decrease with the iterations. Convergence towards the same stationary point than the classical iterative decoding.

An hybrid minimum entropy algorithm

Goal: Improve the performance of the iterative decoding.

Rationale: The entropy of the APP gives a measure of the reliability of the decision : $E_B(\lambda_1+\lambda_2) \rightarrow 0$ means that the iterative decoding is confident about its decisions (Kocarev, 2006).

Demapping $\min_{\lambda_2} D_{FD}(p_{\mathbf{B}\lambda_1+\theta_m}, p_{\mathbf{B}(\lambda_1+\lambda_2)}) + \eta_m E_B(\lambda_1+\lambda_2)$
 Decoding $\min_{\lambda_1} D_{FD}(p_{\mathbf{B}\lambda_2+\theta_c}, p_{\mathbf{B}(\lambda_1+\lambda_2)}) + \eta_c E_B(\lambda_1+\lambda_2)$

Simulation

The generator polynomial of the encoder is $g = [111; 001; 100]$. The bits are mapped using subset partitioning to a 8-PSK modulation. The length of the coded bit sequence is $L_c = 6000$. The step-sizes η_m and η_c in the HMEA are both chosen equal to 0.05.

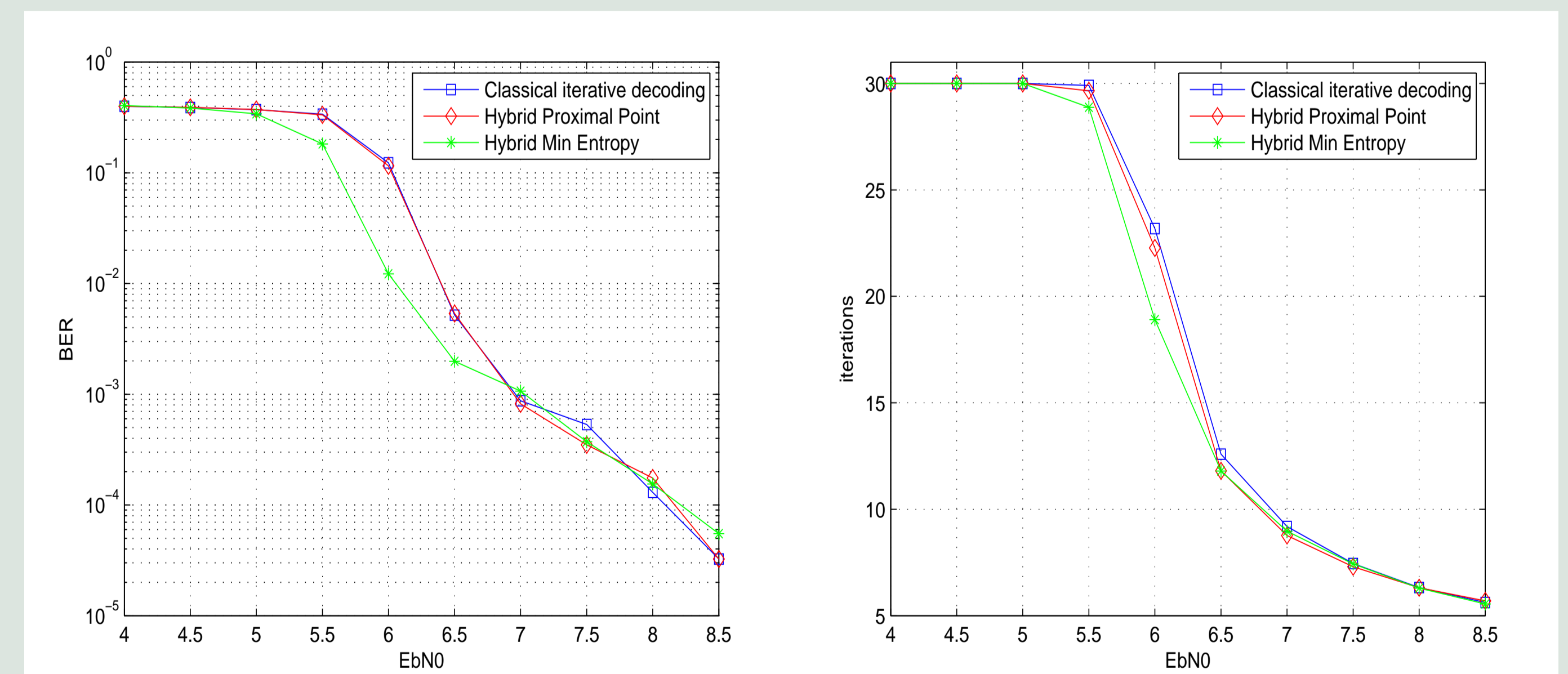

References

- Zehavi. 8-PSK trellis codes for a Rayleigh fading channel. *IEEE Trans on Commun.*, 40:873–883, May 1992.
- Li, A. Chindapol and J.A. Ritcey. Bit interleaved coded modulation with iterative decoding and 8-PSK signaling. *IEEE Trans on Commun.*, 50:1250–1257, Aug. 2002.
- J.M. Walsh, P.A. Regalia and C.R. Johnson. Turbo decoding as Iterative Constrained Maximum Likelihood sequence Decoding. *IEEE Trans on Inform Theory*, 52:5426–5437, Dec. 2006.
- F.J. Luque. Asymptotic convergence analysis of the proximal point algorithm. *SIAM Journal on Control and Optimization*, 22(2), pp. 277–293, 1984.
- L. Kocarev, F. Lehmann, G.M. Maggio, B. Scanavino, Z. Tatsev and A. Vardy. Nonlinear dynamics of iterative decoding systems: Analysis and Applications. *IEEE Trans. on Inform. Theory*, 52(4): 1366–1384, 2006.