



HAL
open science

Baffle silencer with tunable resonators for adaptive control of variable tonal noise

Valérie Pommier-Budinger, Olivier Cherrier

► **To cite this version:**

Valérie Pommier-Budinger, Olivier Cherrier. Baffle silencer with tunable resonators for adaptive control of variable tonal noise. *Journal of Vibration and Control*, 2015, 21 (9), pp.1801-1809. 10.1177/1077546313499928 . hal-01840857

HAL Id: hal-01840857

<https://hal.science/hal-01840857>

Submitted on 16 Jul 2018

HAL is a multi-disciplinary open access archive for the deposit and dissemination of scientific research documents, whether they are published or not. The documents may come from teaching and research institutions in France or abroad, or from public or private research centers.

L'archive ouverte pluridisciplinaire **HAL**, est destinée au dépôt et à la diffusion de documents scientifiques de niveau recherche, publiés ou non, émanant des établissements d'enseignement et de recherche français ou étrangers, des laboratoires publics ou privés.



Open Archive TOULOUSE Archive Ouverte (OATAO)

OATAO is an open access repository that collects the work of Toulouse researchers and makes it freely available over the web where possible.

This is an author-deposited version published in: <http://oatao.univ-toulouse.fr/>
Eprints ID : 14601

To link to this article : DOI :10.1177/1077546313499928
URL : <http://dx.doi.org/10.1177/1077546313499928>

To cite this version: Pommier-Budinger, Valérie and Cherrier, Olivier [Baffle silencer with tunable resonators for adaptive control of variable tonal noise](#). (2015)
Journal of Vibration and Control, vol.21 (n°9). pp.1801-1809. ISSN 1077-5463

Any correspondence concerning this service should be sent to the repository administrator: staff-oatao@listes-diff.inp-toulouse.fr

Baffle Silencer with Tunable Resonators for Adaptive Control of Variable Tonal Noise

VALERIE POMMIER-BUDINGER, OLIVIER CHERRIER

Institut Supérieur de l'Aéronautique et de l'Espace, Université de Toulouse, France

Corresponding author:

Valerie Pommier-Budinger, Institut Supérieur de l'Aéronautique et de l'Espace, 10 Avenue

Edouard Belin - 31055 Toulouse - France

Email: valerie.budinger@isae.fr

Baffle Silencer with Tunable Resonators for Adaptive Control of Variable Tonal Noise

Abstract

The article presents a baffle silencer with tunable resonators consisting of two superimposed and identically perforated plates associated with a partitioned cavity made of thermoplastic resin. One plate is fixed while the other is movable. Displacement of the mobile plate changes the internal shapes of the resonator necks and shifts the resonance frequency of the system to lower values. The contributions of this paper are firstly, the modeling of a panel with tunable resonators made of necks with a variable geometry and a partitioned cavity in resin and, secondly, the use of the model to elaborate a control strategy to attenuate variable tonal noise. All of the theoretical studies are validated by experimental measurements. Final results show the efficiency of the silencer in attenuating a tonal noise that varies between 2000 and 2800 Hz.

Keywords

Baffle silencer, tunable resonators, neck geometry, partitioned cavities, acoustic impedance, adaptive noise control

NOMENCLATURE

- c*: sound speed
- D*: mobile plate displacement
- k*: wave number equal to ω/c
- L*: cavity depth

- l_e : short distance between to two holes
- L_e : long distance between to two holes
- l_1 : thickness of plate 1
- l_2 : thickness of plate 2
- r : hole perforation radius
- R : normalized acoustic resistance
- R_s : normalized acoustic resistance per unit of area equal to $\sqrt{\frac{\mu\omega c_0}{2}}$
- S_{cavity} : cavity surface
- S_{hole} : hole surface
- ω : angular frequency pulsation
- X : normalized acoustic reactance
- Z : normalized acoustic impedance ($Z=R+jX$)
- δ_e : exterior mass end correction equal to $\frac{8r}{3\pi}$
- δ_i : interior mass end correction equal to $\delta_e(1-1.25\sigma^{0.5})$
- μ : dynamic viscosity of air
- σ : open area ratio
- σ_{cavity} : open area ratio of the cavity
- σ_{plate} : open area ratio of the plate

1. INTRODUCTION

The article focuses on silencers with acoustic resonators made of perforated sheets bonded onto honeycomb cavities for noise reduction. The advantage of these resonators is that they can be used

in harsh conditions. Their main drawback is that they are selective in frequency. They are thus efficient for tonal noise reduction. In the case of variable tonal noise, the efficiency is limited if the resonators are not tunable. Many studies have been performed on adaptive resonators and have led to patents: Kotera et al. (1994), McLean (1998), Cheng et al. (1999), Paschereit et al. (2003), Stuart (2003), Kotsun et al.(2004), Kudernatsch (2004), Ciray (2005). The reading of these patents enables identifying two types of solutions to obtain adaptive resonators: either by the control of the volume of the cavities, or by the control of the neck (perforated holes) geometry.

In order to control the volumes of the cavities, Konishi et al. (1998) proposed tunable acoustic resonators whose depth is controlled by C-shape micro actuators. De Bedout et al. (1997) used a rotating internal radial wall inside the resonator cavity to vary the volumes of the cavities. Kostek et al. (2000) studied the robust feedback control of such systems. Kobayashi et al. (2007) successfully implemented resonators with tunable cavities in a turbofan.

With respect to the control of the neck geometry and the study of its influence on the resonator acoustic behavior, Birnbach et al. (2006) studied a resonator with two perforated plates and an inlet air gap. They demonstrated that for a very small distance between the plates from 0.05 mm to 0.1 mm, the resonators have high acoustic impedance and low absorption and that, by increasing the distance, the impedance decreases and the absorption becomes maximum. Chanaud (1997) studied the radiation impedance for geometries of non-circular orifices. Tang (2005) studied a resonator with a tapered neck. Results show that the resonance frequency increases with the tapering length and that absorption increases with the tapered neck slope. Esteve et al. (2004) proposed to tune the resonator by using an accordion neck to vary the length of the neck or by using an iris diaphragm to vary the resonator opening.

As changing the volumes of cavities requires heavy machinery that may be unsuitable for some applications (e.g. aerospace applications), this article proposes to study adaptive resonators whose neck geometry can be controlled. An easy way to produce such resonators is to associate two superimposed and identically perforated plates with air cavities. One plate is fixed and bonded to the cavities and the other plate is movable. This concept enables changing the internal shapes of the holes of the perforated layers and the resonance frequency of the system. These tunable resonators have already been studied by Powell et al. (2000). They showed that the resonance frequency shifts to lower values but they failed to develop a model. A circular silencer with adaptive resonators based on the same principle (two inner cylinders, a fixed one and a movable one, associated with a cavity) has been developed by Nagaya (2001) in order to reduce a blower noise with two varying peaks. He proved the efficiency of the system but did not develop a model for the silencer. In Cherrier et al. (2012), we developed a model of such tunable resonators with two perforated plates. We now have built a baffle silencer with panels of tunable resonators made with two plates and this article proposes the model and the control of this baffle silencer.

Part 2 of the article develops the geometry of the tunable acoustic resonators and describes the baffle silencer. Part 3 deals with the modeling of a silencer panel made of an array of tunable resonators. The acoustic impedance at normal incidence of a tunable resonator panel is computed, as well as the acoustic absorption coefficient. All computation results are validated by experimental results in an impedance tube. Finally, in part 4, the performance of the silencer is evaluated and the control of the silencer is demonstrated. The capability of the silencer to track and attenuate a tonal noise that varies according to a frequency ramp is measured.

2. BAFFLE SILENCER WITH TUNABLE RESONATORS

2.1. Description of tunable resonators

Helmholtz resonators are characterized by a high absorption coefficient but are selective in frequency: such resonators are efficient around a resonance frequency that depends on the size, shape and porosity of the necks and on the thickness of cavities. In order to vary the resonance frequency, we propose to use tunable resonators whose necks are generated by two perforated plates, side by side, one fixed and one mobile (Figure 1). The mobile plate can translate a distance that can vary from zero to the hole perforation diameter ($2r$). These resonators have been studied in Cherrier et al. (2012).

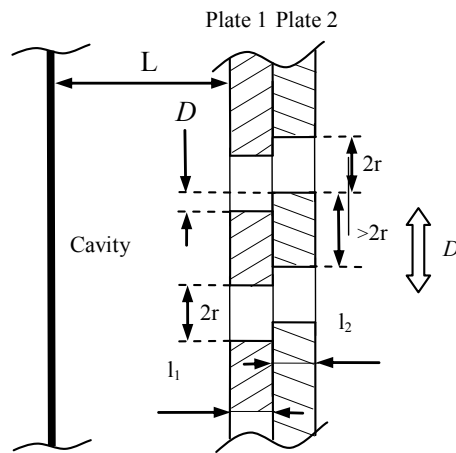

Figure 1. Principle of the tunable resonator with two perforated plates and a single cavity

2.2. Description of the baffle silencer

The silencer is made of three baffles with tunable resonators on each side (Figure 2 and Figure 3). There are so six noise absorbent panels. The mobile parts of the three baffles are actuated by a single electromechanical linear actuator (Part B). The link between the actuator and the mobile parts of baffles is rigid, so the displacement of the actuator is the same as that of the baffles. A loudspeaker (Part A) is connected to one end of the silencer to generate noise to test the silencer.

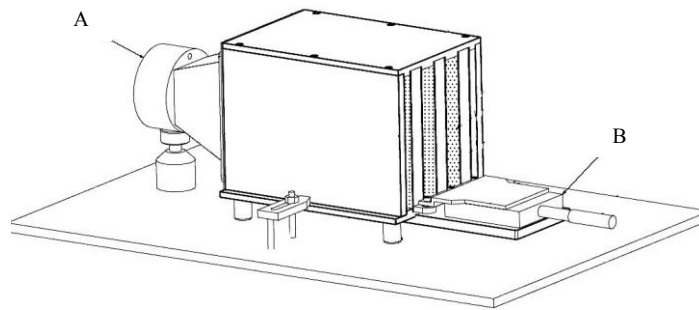

Figure 2. Scheme of the silencer

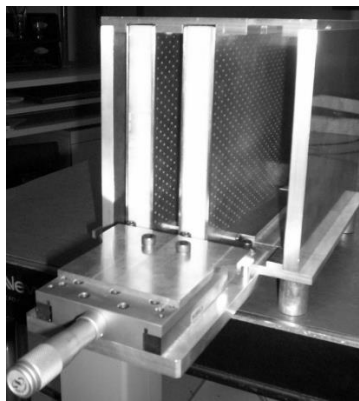

Figure 3. Picture of the silencer under manufacturing with 2 baffles inside

Each absorbent panel is composed of two brass plates and of an array of cavities made by rapid prototyping in Acrylonitrile Butadiene Styrene (ABS) thermoplastic resin. The cavities are distributed in a honeycomb structure as shown in Figure 4 with $L_e = 7\text{mm}$ and $l_e = 6\text{mm}$.

The characteristics of the baffles are as follows:

- baffle sizes:
 - length: 222mm
 - width: 148mm
- gap between 2 baffles: 22mm
- resonators sizes:
 - thicknesses of the perforated plates: 1mm

- diameter of the holes in the perforated plates: 1.5mm
- cavity depth: 7.2mm
- cavity sizes: hexagonal with circumscribed circle of diameter 6mm (Figure 4).

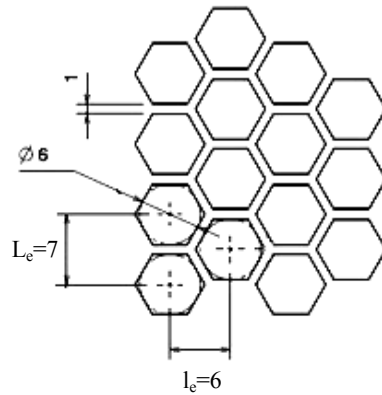

Figure 4. Cavities in honeycomb

3. MODEL OF A TUNABLE RESONATORS PANEL WITH AN ARRAY OF CAVITIES IN THERMOPLASTIC RESIN

3.1. Limitation of the previous model

In Cherrier et al. (2012), we have established a model for a panel of tunable resonators whose necks are generated by two perforated plates, one fixed and one mobile, and with a single cavity in metal. This model allows one to compute the normalized reactance and the normalized resistance in normal incidence, as well as the sound absorption coefficient for different displacements D of the mobile plate. It is then possible to deduce the resonance frequency for each case of displacements and thus to evaluate the useful frequency range of tunable resonators. When applying the proposed model to our silencer panel and when comparing modeling results and experimental results from measurements made in an impedance tube, differences appeared as shown in Figure 5. The

estimation of the resonance frequencies is accurate but the thicknesses and the amplitudes of the resonance peaks are either much lower or greater than the measured ones.

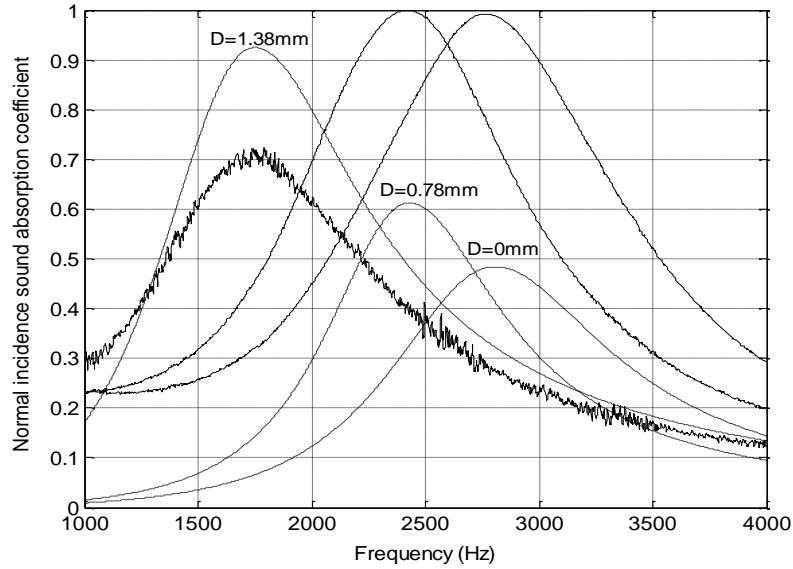

Figure 5. Absorption coefficient at normal incidence for displacements D of the mobile plate ($D=0\text{mm}$, $D=0.78\text{mm}$, $D=1.38\text{mm}$): computed with the model of Cherrier et al. (2012) (- - -) and measured (—)

The differences can be explained by two facts:

1 - Compared to the resonators studied in Cherrier et al. (2012), the cavity of the silencer panel is partitioned in several small cavities and, because of the manufacturing method, the thickness of the cavities wall is not negligible (1mm).

2 – The silencer cavities are made of ABS resin, and therefore the acoustic impedance of the bottom of the cavity cannot be regarded as infinite, as opposed to the bottom of a cavity in metal. Moreover, the surface of the cavities is rough because of the manufacturing process (3D printing) and there may be traces of glue in the cavities due to the bonding of the fixed perforated plate onto the cavities. This increases the acoustic resistance of the silencer panel.

3.2. Up-dating the model

The model proposed in Cherrier et al. (2012) can be improved to take into account the repartition of the resonators, the wall thickness and the influence of the cavities material.

To model the repartition of the resonators and the wall thickness, it is necessary to define another open area ratio as proposed in Allard et al. (2009). It corresponds to the open area ratio of the plate:

$$\sigma_{plate} = \frac{S_{hole}}{L_e l_e} \quad (1)$$

To model the losses in the ABS material and on its surface, an acoustic normalized resistance at the interface of the cavities and of the perforated plate 1 (Figure 1) must be added to the model. It has been measured on a sample in ABS material in an impedance tube and its mean value on the frequency range of the model is:

$$R_{loss} = 11 \quad (2)$$

Finally, the normalized impedance at normal incidence of the panel with tunable resonators in plastic resin can be expressed as:

$$Z_{panel} = R_{panel} + jX_{panel} \quad (3)$$

with normalized acoustic resistance R_{panel} :

$$R_{panel} = \frac{1}{\sigma_{plate}} \left(R_{loss} + 2R_s \left(\frac{1 - \frac{\ell_E}{2}}{r} + 1 \right) + \frac{S_{hole}}{S_E} 2R_s \left(\frac{\ell_E P_E}{4S_E} + 1 - \frac{S_E}{S_{hole}} \right) + 2R_s \left(\frac{1 - \frac{\ell_E}{2}}{r} + 1 \right) \right) \quad (4)$$

and normalized acoustic reactance X_{panel} :

$$X_{panel} = \frac{1}{\sigma_{plate}} \left(-\sigma_{cavity} \cot(kL) + k \left(1 - \frac{\ell_E}{2} + \delta_i \right) + k \ell_E \frac{S_{hole}}{S_E} + k \left(1 - \frac{\ell_E}{2} + \delta_e \right) \right) \quad (5)$$

that are both functions of the geometry and of mobile plate translation D .

In equation (5), interior mass end correction δ_i equals to $\delta_e \left(1 - 1.25\sigma_{plate}^{0.5}\right)$.

Note: P_E , S_E and ℓ_E were defined in Cherrier et al. (2012) as the perimeter, the surface and the length of an elliptic piston created by the overlapping of the two perforated plates and representing an additional mass of air in motion near the orifice lips of the tunable resonator.

3.3. Model validation

The new model is validated by comparing simulation results with experimental results obtained in an impedance tube with a sound level of 110dB. Figure 6 to Figure 8 show respectively the absorption coefficient, the normalized reactance and the normalized resistance for different displacements D in mm of the mobile plate. Figure 6 shows that the amplitudes of the resonance peaks and their thicknesses are now closer to the measurements results. Figure 7 shows that the estimation of the resonance frequency of the panel (frequency for which one reactance is null) is very accurate.

Table 1 gives the percentage error between computed and measured resonance frequencies. The estimation of the resistive effects that come from the viscous interaction between acoustic flow and structure (Figure 8) is less accurate. The behavior is not well-characterized in low frequencies. Modeling these phenomena is more difficult.

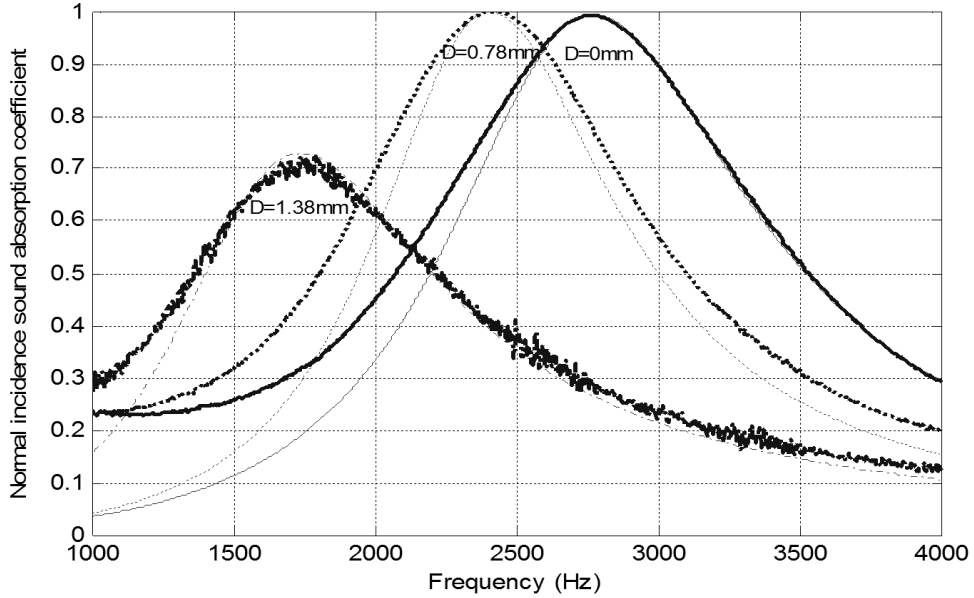

Figure 6. Absorption coefficient at normal incidence for displacements D of the mobile plate
 Curves computed with the new model: $D=0\text{mm}$ (—) , $D=0.78\text{mm}$ (- - - -), $D=1.38\text{mm}$ (- - - -)
 Measured curves: $D=0\text{mm}$ (——) , $D=0.78\text{mm}$ (- - - -) , $D=1.38\text{mm}$ (- · - · - · -)

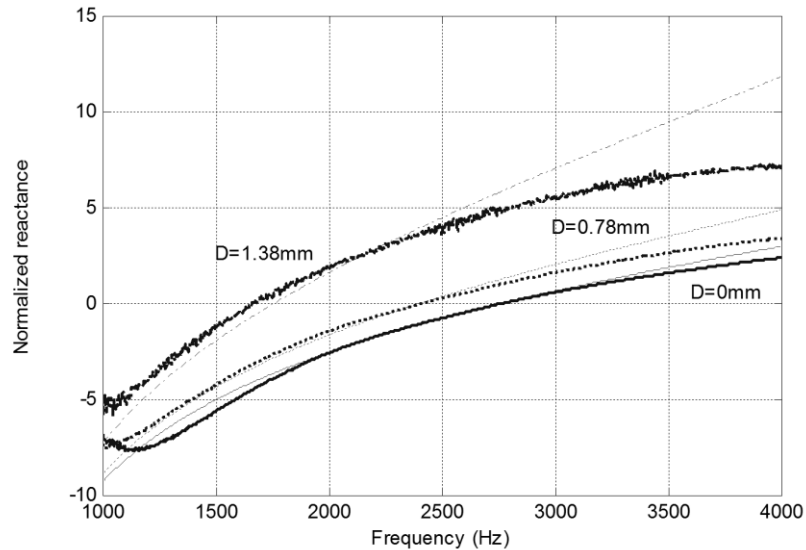

Figure 7. Normalized reactance at normal incidence for displacements D of the mobile plate
 Curves computed with the new model: $D=0\text{mm}$ (—) , $D=0.78\text{mm}$ (- - - -), $D=1.38\text{mm}$ (- - - -)
 Measured curves: $D=0\text{mm}$ (——) , $D=0.78\text{mm}$ (- - - -) , $D=1.38\text{mm}$ (- · - · - · -)

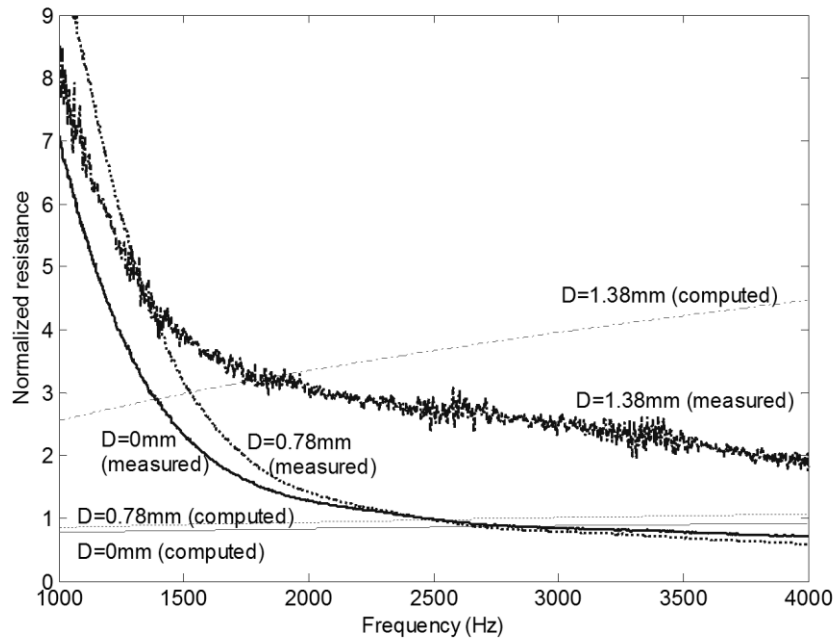

Figure 8. Normalized resistance at normal incidence for displacements D of the mobile plate
 Curves computed with the new model: $D=0\text{mm}$ (—), $D=0.78\text{mm}$ (- - -), $D=1.38\text{mm}$ (- - - -)
 Measured curves: $D=0\text{mm}$ (——), $D=0.78\text{mm}$ (- - - -), $D=1.38\text{mm}$ (- · - · - · -)

Mobile place displacement	Computed resonance frequencies (Hz)	Measured resonance frequencies (Hz)	Percentage error
$D = 0\text{mm}$	2773	2775	0.07%
$D=0.78\text{mm}$	2408	2420	0.5%
$D=1.39\text{mm}$	1675	1740	3.73%

Table 1. Comparison of computed and measured resonance frequencies

4. CONTROL OF THE BAFFLE SILENCER

4.1. Silencer attenuation

Before tackling the issue of control, the attenuation of the silencer is measured on the frequency range 1800-2800Hz with a step of 100Hz. An input tonal noise that consists of a single sine wave at fixed frequency is generated by the loud speaker and then the acoustic sound power of the source is measured with and without the silencer. The acoustic attenuation is the difference between these two acoustic sound powers.

For each frequency, the mobile plates of all panels are moved of the same displacement in order to get the best attenuation. The experimental results are given in Figure 9 and correspond to the legend “silencer in active mode”.

The acoustic attenuation is also measured when there is no displacement of the mobile plates. The silencer is then said to be in “passive mode”.

For frequencies around 2800 Hz, the silencer has the same behavior in active and passive mode since the displacement of the mobile plates is null. The maximum gain is obtained at 2400 Hz: the attenuation is increased by 20 dB with the silencer in active mode compared with the silencer in passive mode. Below 1800 Hz, the attenuation produced by the silencer is weak or null, even in active mode, since the maximum displacement of the mobile plates is reached.

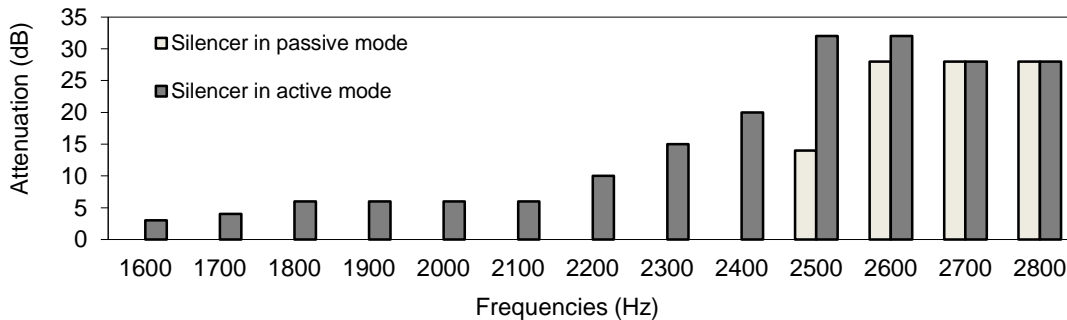

Figure 9. Silencer attenuation

4.2. Control strategy

The control strategy is synthetized by the diagram of Figure 10.

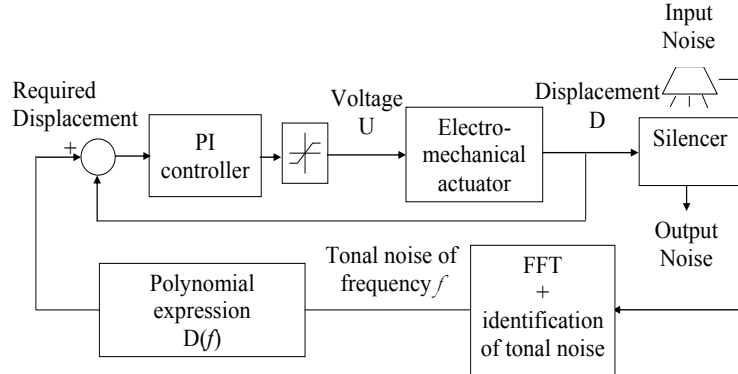

Figure 10. Control strategy of the silencer

The electromechanical actuator that enables the displacement of the mobile plates is controlled in position with a proportional-integral controller in order to ensure good accuracy. The displacement of the actuator rod is supposed to be equal to that of the mobile plates since the connection between the mobile plates and the actuator is rigid.

The mobile plates displacement required to best attenuate a tonal noise is computed from a FFT analysis of the measured noise. The FFT enables the determination of the frequency of the most disturbing tonal noise (tonal noise with the highest magnitude). The displacement required to attenuate the tonal noise is then computed by using a relation between the displacement of the mobile plates and the resonance frequency of the absorbent panels in the silencer. This relation has been extracted from the panel model of section 3.2. Indeed, for frequencies between 1800 and 3000Hz, the displacement for which the attenuation is the highest has been computed and a polynomial expression of the silencer acoustic behavior has been established. The polynomial that gives displacement D (in meter) versus frequency f (in Hz) is:

$$D(f) = 1.142e^{-12}f^3 - 8.6e^{-9}f^2 + 2e^{-5}f - 1.35e^{-2} \quad (6)$$

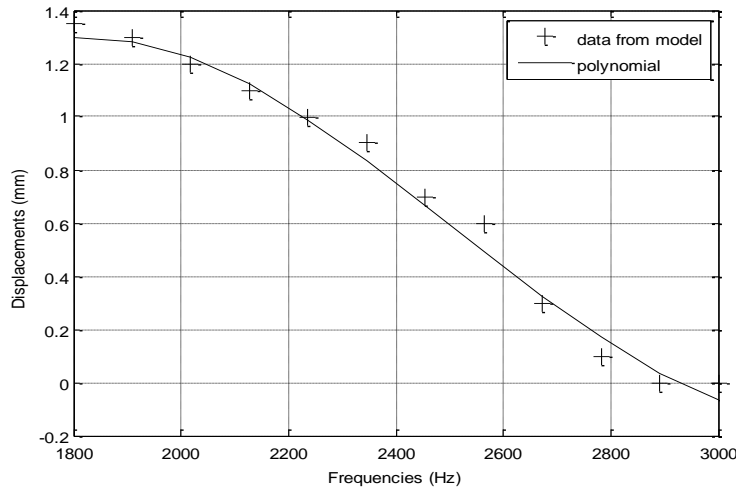

Figure 11. Acoustic behavior of the silencer

4.3. Experimental results

Some experimental tests are performed to validate the proposed adaptive noise control system. The silencer is placed in the middle of a room of large volume where reflection from the walls has been reduced with absorbent materials. The distance between the noise source and the floor is 1.2m. The distance between the microphone and the silencer output is 1m. The measurements are performed in the output axis of the silencer.

The silencer is first used to reduce a pure variable tonal noise consisting of a sine wave whose frequency varies as a ramp between 2800Hz and 2000 Hz in 10s. Figure 12(a) represents the frequency sweep of the sine wave. Figure 12(b) shows the sound level in dB at the output of the silencer when the silencer is in passive mode (no displacement of the mobile plates) and in active mode. The displacement of the mobile plates measured when the silencer is in active mode is shown in Figure 12(c).

In passive mode, as the displacement of the mobile plates is null, the silencer is configured to attenuate mainly the frequencies around 2800Hz. So the output noise is minimal at the beginning of

the test that starts at 2800 Hz and increases as the frequency of the input tonal noise decreases. In active mode, the displacement of the mobile plates increases as the frequency decreases. The output noise is also increasing but much less than in passive mode. For 2400Hz, the gain between the silencer in passive and active mode is of 20dB, which is consistent with the results of Figure 9.

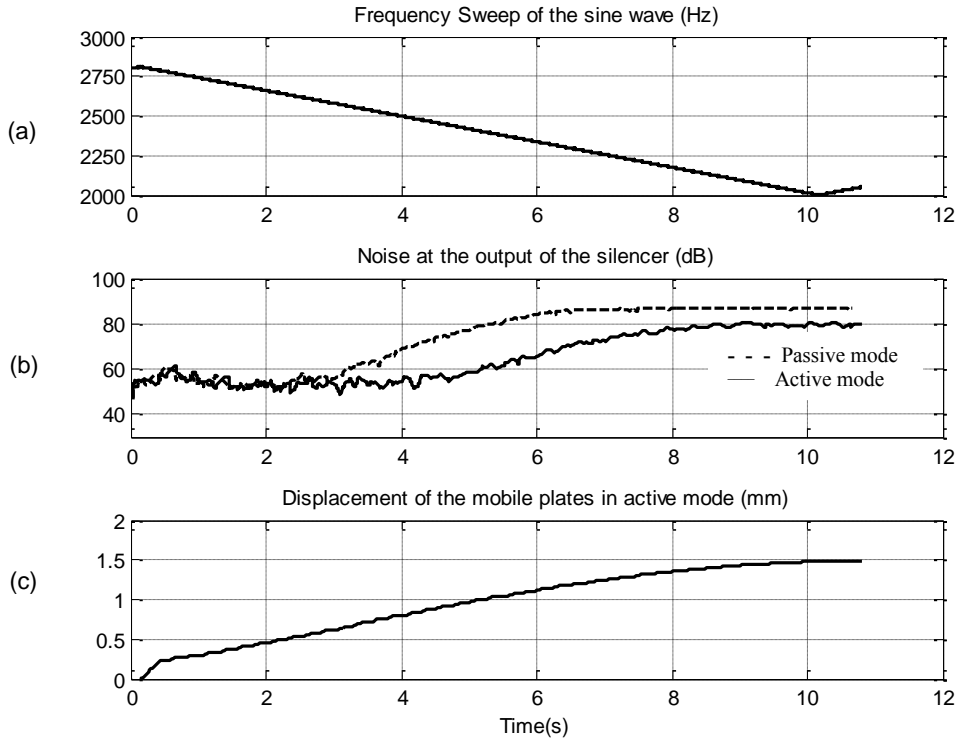

Figure 12. Experimental results of the baffle silencer with tunable resonators with a swept sine wave

The silencer is then tested where the noise consists of a stepped sine wave whose frequency varies between 2400Hz and 2800 Hz in 8s. Figure 13(a) represents the frequency step of the sine wave. Figure 13(b) gives the sound level in dB at the output of the silencer in active mode and Figure 13(c) the displacement of the mobile plates. This test shows that the control is efficient and allows evaluating the dynamics of the silencer under these conditions. It takes 1.6s for the plates to reach

the good position when the frequency of the sine wave varies from 2800Hz to 2400Hz and 0.9s when the frequency of the sine wave varies from 2400Hz to 2800Hz.

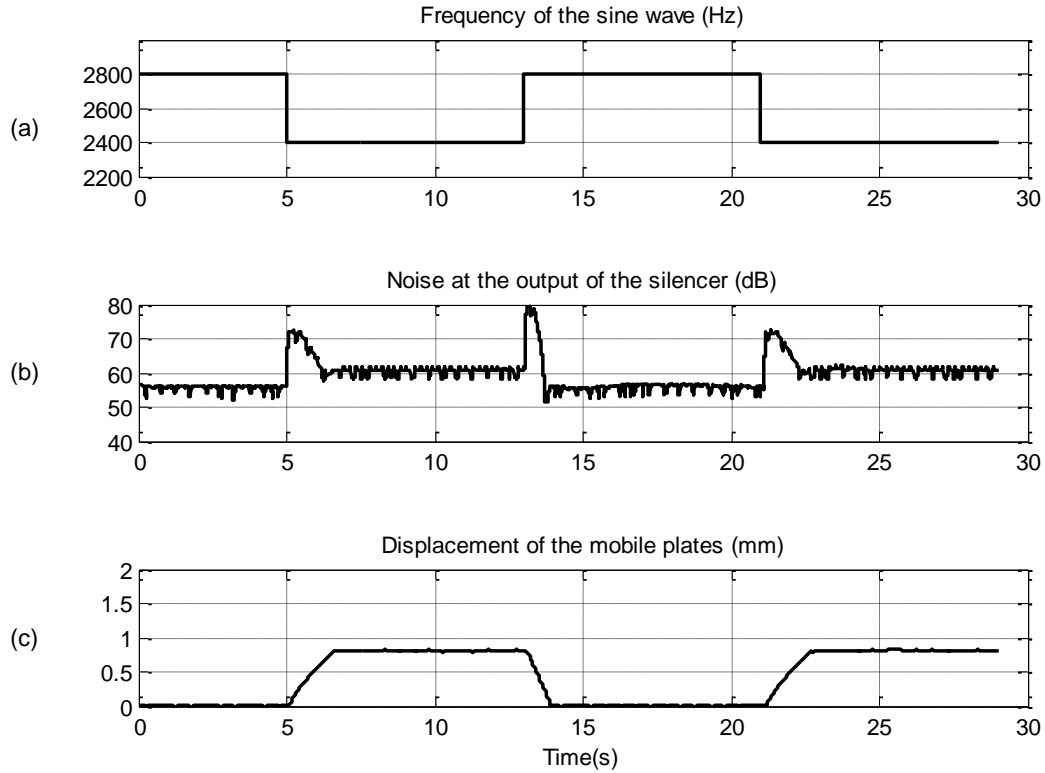

Figure 13. Experimental results of the baffle silencer with tunable resonators with a stepped sine wave

5. CONCLUSION

This article presents a baffle silencer with tunable resonators for the adaptive noise control of varying tonal noise. The tunable resonators consist of two superimposed and identically perforated plates associated with cavities. One plate is mobile and when it is moving, the necks of the resonators are restricted. The resonance frequency then shifts to lower values.

A model of a tunable resonator panel is proposed and validated by experimental measurements. This model is used to determine the frequency range at which the silencer will be efficient. It is also used to elaborate a strategy to control the silencer. Results show the efficiency of the silencer to attenuate a tonal noise that varies between 2000 and 2800 Hz.

The proposed adaptive noise control system is easy to implement and different from active noise control systems based on the interference with secondary noise sources. It can be used for machines with variable tonal noises such as fans of aircraft engines and rotating machines controlled at variable speed.

In reference to the model of the tunable resonators baffle, as some of the foreseen applications (e.g. fans controlled at variable speed) are exposed to flow, it would be relevant in future work to take into account the flow over the perforated interface. It could also be useful to build a model that includes high acoustic excitation levels.

With respect to the silencer, improvements can be made to the system by choosing a smaller actuator with a better dynamics to get a more compact solution and to improve the response time of the silencer. The control strategy can also be improved by regularly measuring the behavior of the silencer and by calculating from these measurements the polynomial used in the control law. This update of the polynomial would make the silencer less sensitive to system changes during its use.

REFERENCES

- Allard J and Attala N (2009) *Propagation of sound in porous media: modeling sound absorbing materials*. Wiley-Blackwell
- Birnback M, Sliwinski A and Zachara S (2006) Increasing of sound absorption proprieties of acoustical panels based on Helmholtz resonators of double plates with orifice

- inlet neck by geometrical configuration variations. In: *Proceedings of the Meeting of Internoise*, Hawaii, December 2006
- Chanaud RC (1997) Effects of geometry on the resonance frequency of Helmholtz resonators. *Journal of Sound and Vibration* 204: 829-834
- Cheng CR, McIntosh JD, Zuroski MT et al. (1999) Tunable acoustic system. *United States Patent* Number 5,930,371
- Cherrier O, Pommier Budinger V and Simon F (2012) Panel of resonators with variable resonance frequency for noise control, *Journal of applied Acoustics* 73: 781–790
- Ciray MS (2005) Exhaust processor with variable tuning system. *United States Patent* Number 6,915,876.
- De Bedout JM, Franchek MA, Bernhard RJ et al. (1997) Adaptive-passive noise control with self-tuning helmholtz resonators, *Journal of Sound and Vibration* 202: 109–123
- Estève SJ and Johnson ME (2004) Development of an Adaptive Helmholtz Resonator for Broadband Noise Control. In: *Proceedings of the ASME International Mechanical Engineering Congress and Exposition*, Anaheim, November 2004
- Kobayashi H, Koh M, Ozaki S et al. (2007) Newly-developed adaptive noise absorption control technology for high speed fan noise reduction. *JSME International Journal*, 49: 703-712
- Konishi S, Yoda M, Hosaka N et al. (1998) Tunable acoustic absorbing system using a deep hole array. In *Proceedings of the Micro Electro Mechanical Systems*, Germany, January 1998
- Kostek TM and Franchek MA (2000), Hybrid noise control in ducts. *Journal of Sound and Vibration* 237: 81-100

- Kotera H and Okhi S (1994) Resonator type silencer. *United State Patent* Number 5,5283,398
- Kotsun JD, Goenka LN, Moenssen DJ et al. (2004) Helmholtz resonator. *United States Patent* Number 6,792,907
- Kudernatsch G (2004) Exhaust gas system with Helmholtz resonator. *United States Patent* Number 6,705,428
- McLean IR (1998) Variably tuned Helmholtz resonator with linear response controller. *United States Patent* Number 5,771,851
- Nagaya K, Hano Y and Suda A (2001) Silencer consisting of a two stage Helmholtz resonator with auto-tuning control. *Journal of the Acoustical Society of America* 110: 289-295
- Paschereit CO, Weisenstein W, Flohr P et al. (2003) Apparatus for damping acoustic vibrations in a combustor. *United States Patent* Number 6,634,457
- Powell CA and Preisser JS (2000) NASA's subsonic jet transport noise reduction research, *NASA Langley Research Center*
- Stuart PER (2003) Variable resonator. *United States Patent* Number 6,508,331
- Tang SK (2005) On Helmholtz resonators with tapered neck. *Journal of Sound and Vibration* 279: 1085-1096