



**HAL**  
open science

## NoC based virtualized accelerators as cloud services

Hiliwi Leake Kidane, El-Bay Bourennane

► **To cite this version:**

Hiliwi Leake Kidane, El-Bay Bourennane. NoC based virtualized accelerators as cloud services. 11ème Colloque du GDR SoC-SiP, Jun 2016, Nantes, France. hal-01821101

**HAL Id: hal-01821101**

**<https://hal.science/hal-01821101>**

Submitted on 22 Jun 2018

**HAL** is a multi-disciplinary open access archive for the deposit and dissemination of scientific research documents, whether they are published or not. The documents may come from teaching and research institutions in France or abroad, or from public or private research centers.

L'archive ouverte pluridisciplinaire **HAL**, est destinée au dépôt et à la diffusion de documents scientifiques de niveau recherche, publiés ou non, émanant des établissements d'enseignement et de recherche français ou étrangers, des laboratoires publics ou privés.

## Abstract

Hardware accelerators (HwAcc) provide good performance in computation intensive applications. Integrating hardware accelerators in a cloud environment is the optimal way to improve the quality of service. However, mapping all possible application statically into the reconfigurable fabric of the FPGA is rather impractical and prohibitively expensive in terms of resource and power consumption. This problem can be alleviated via time multiplexing the access to the underlying hardware resources, FPGA, by designing dynamically reconfigurable accelerators in the cloud. Similarly, the connection and communication between the accelerators and the reconfigurable control will not be efficient without the use of Network-on-Chip (NoC). In order to address these issues, we propose a NoC based virtualized accelerators for cloud computing.

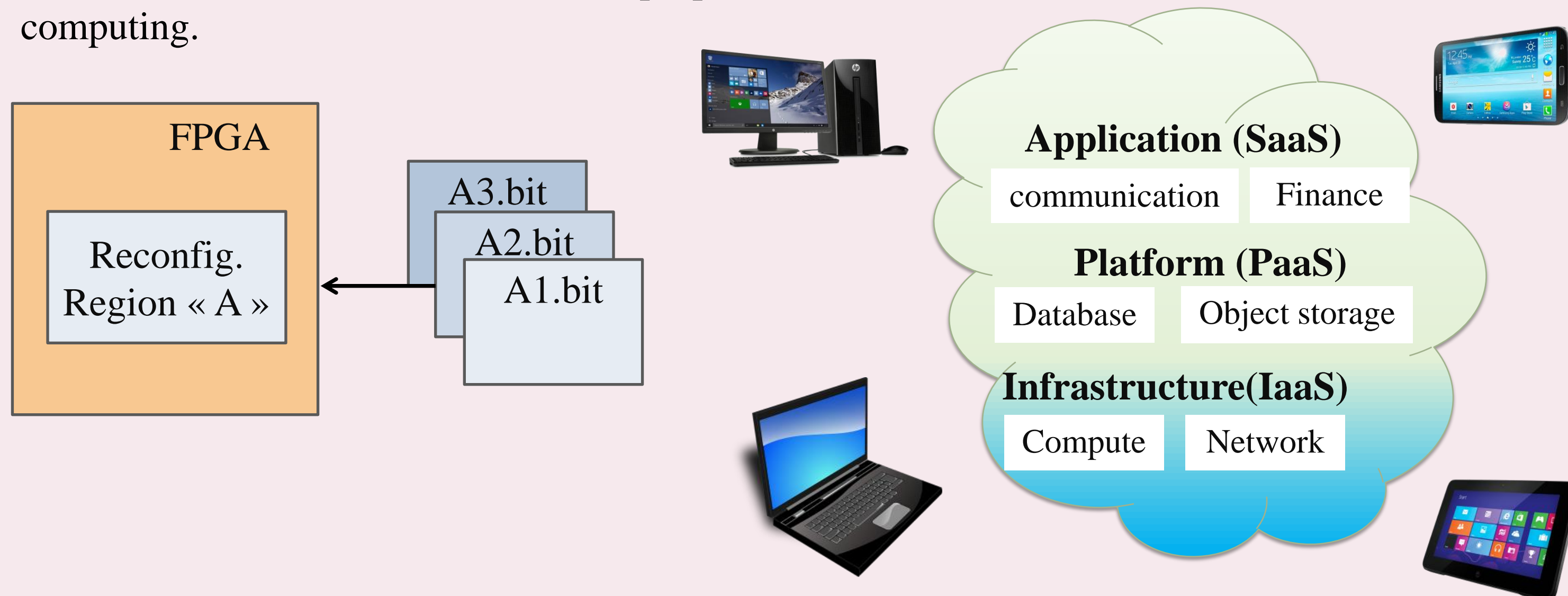

Figure 1. Basics of Partial reconfiguration and Cloud Computing

## OBJECTIVES

The main objective of this project is to integrate virtualized FPGA into cloud computing and then propose two possible FPGA based cloud service:

1. Reconfigurable IPs as a Service (RIPaaS)
2. Reconfigurable Region as a Service (RRaaS)

## METHOD

In recent years, it has been demonstrated that FPGA resources deployed in a cloud environment can be accessed with the same OpenStack software technology used to access virtual machines

OpenStack is a cloud operating system that controls large pools of compute, storage, and networking resources throughout a datacenter

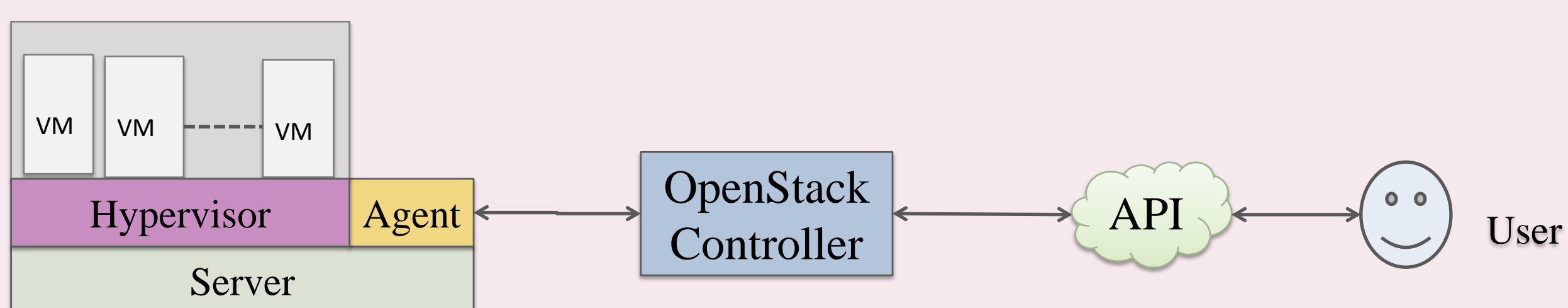

Figure 2. Virtual Machine service using Openstack

Similar to the above VM, the FPGA can be virtualized using the DPR technique so that multi-users can share it in time multiplexing. The static region of the FPGA will be the Hypervisor.

The NoC will allow HwAcc to communicate in parallel between each other and the control manager. In addition, it is faster than OpenFlow, a software-defined networking (SDN) proposed by [2] which is based on header matching

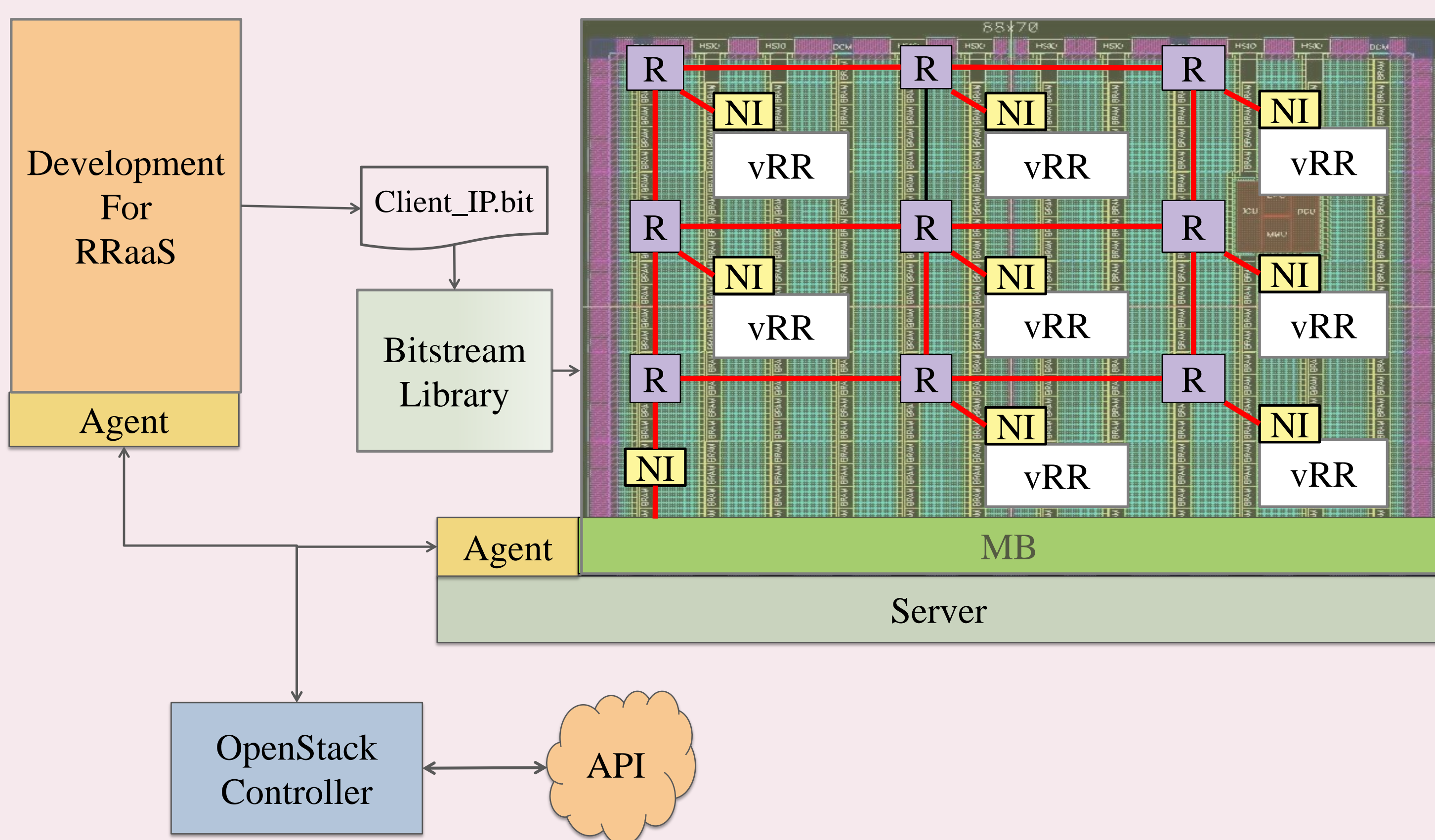

Figure 3. virtualized FPGA cloud services managed by Openstack

## Reconfigurable IPs as a Service (RIPaaS)

In this service the user will not have direct access to the FPGA.

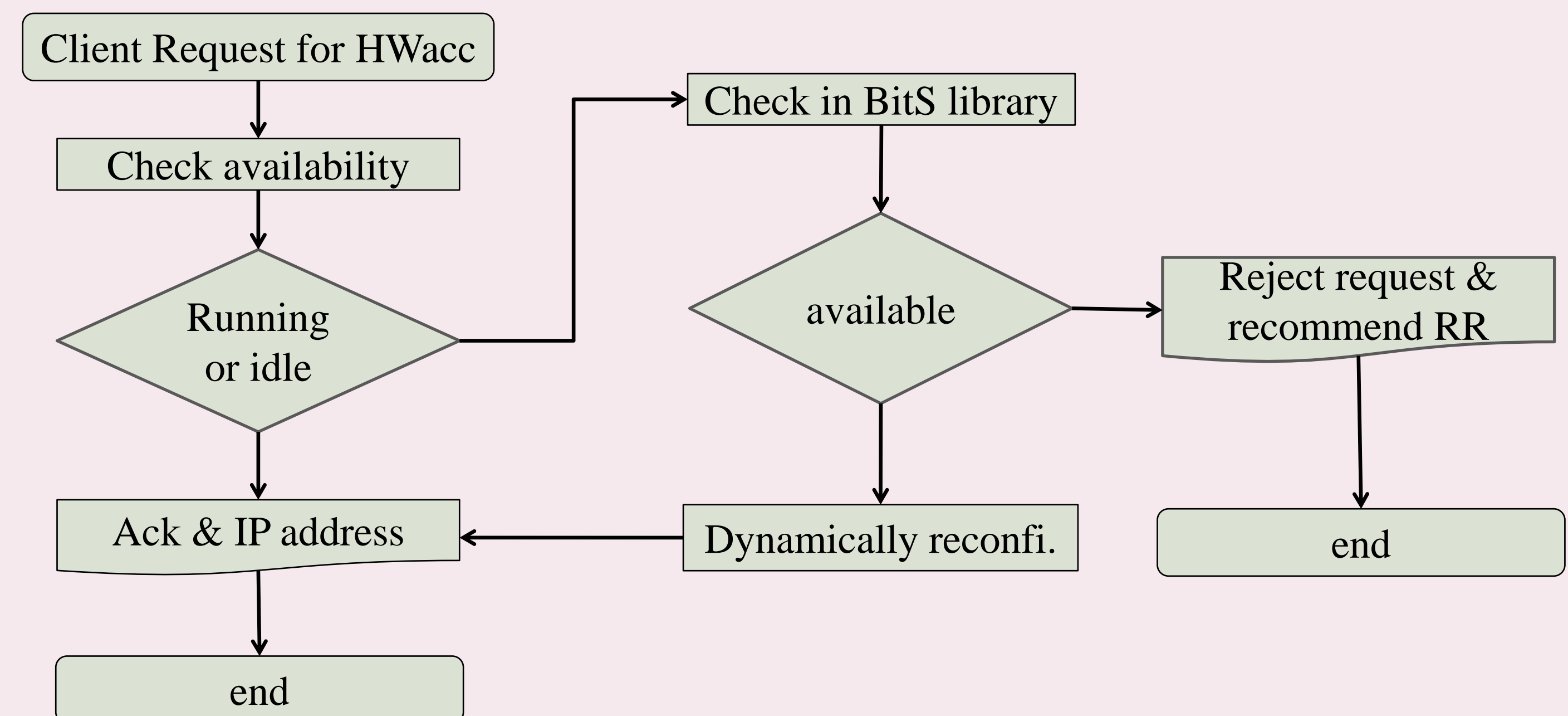

Figure 4. Flow diagram of HW accelerators as a service

## Reconfigurable Region as a Service (RRaaS)

In this service, the user has access to the top-level of available virtualized reconfigurable region.

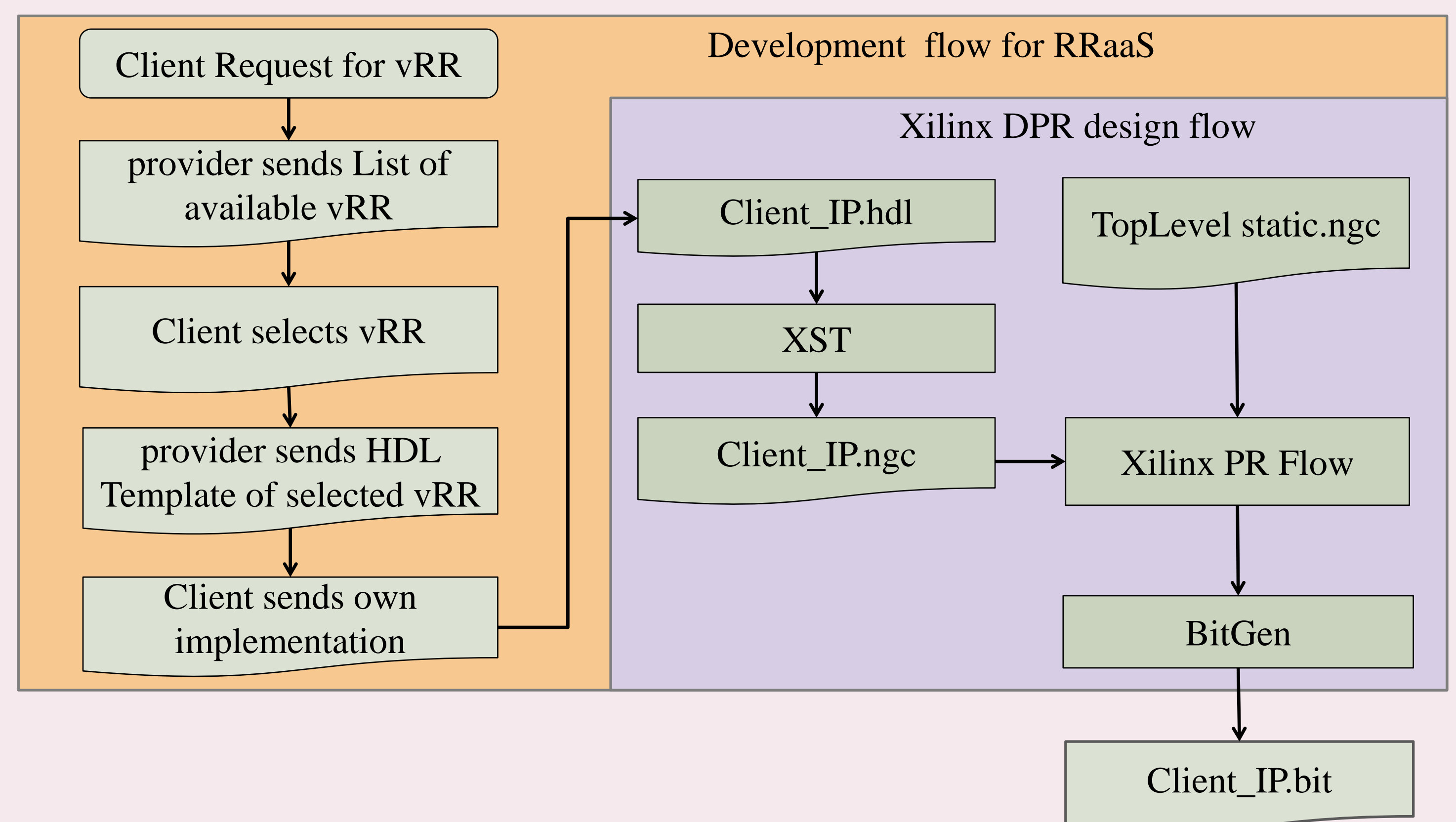

Figure 5. Flow diagram of RRaaS

## Conclusions

We have implemented a NoC based virtualized FPGA and tested locally to share the FPGA resources on cloud context. Integration of hardware accelerators in the cloud improves performance and computational efficiency. Moreover, the dynamic partial reconfigurable accelerators save resources as underutilized accelerators share the same resources in time multiplexing. The NoC provides a layered and scalable communication between accelerators.

## Future works

- Extend the NoC into dynamically reconfigurable
- Implement application layer to access the resources from remote or provide the service for remote users
- Deploy the NoC based virtualized accelerators into server and test via API

## REFERENCES

1. F. Chen, Y. Shan, Y. Zhang, et al., "Enabling FPGAs in the cloud", in Proceedings of the 11th ACM Conf. on Computing Frontiers, ACM, 2014, p. 3.
2. S. Byma, J. G. Steffan, H. Bannazadeh, et al., "FPGAs in the Cloud: Booting Virtualized Hardware Accelerators with OpenStack", Field-Programmable Custom Computing Machines (FCCM), 2014 IEEE 22nd Annual Int'l Symposium on, pp. 109–116, 2014.
3. J. Dondo Gazzano, F. Sanchez Molina, F. Rincon, et al., "Integrating reconfigurable hardware-based grid for high performance computing", The Scientific World Journal, 2015.
4. O. Knodel and R. G. Spallek, "RC3E : Provision and Management of Reconfigurable Hardware Accelerators in a Cloud Environment," 2015.
5. S. A. Fahmy, K. Vipin, and S. Shreejith, "Virtualized fpga accelerators for efficient cloud computing," in Cloud Computing Technology and Science (CloudCom), 2015 IEEE 7th International Conference on, Nov 2015, pp. 430–435.