



**HAL**  
open science

## 2nd YADE Workshop: Discrete-based modeling of multi-scale coupled problems. Booklet of abstracts

Jérôme Duriez

► **To cite this version:**

Jérôme Duriez (Dir.). 2nd YADE Workshop: Discrete-based modeling of multi-scale coupled problems. Booklet of abstracts. 72 p., 2018. hal-01818914

**HAL Id: hal-01818914**

**<https://hal.science/hal-01818914v1>**

Submitted on 19 Jun 2018

**HAL** is a multi-disciplinary open access archive for the deposit and dissemination of scientific research documents, whether they are published or not. The documents may come from teaching and research institutions in France or abroad, or from public or private research centers.

L'archive ouverte pluridisciplinaire **HAL**, est destinée au dépôt et à la diffusion de documents scientifiques de niveau recherche, publiés ou non, émanant des établissements d'enseignement et de recherche français ou étrangers, des laboratoires publics ou privés.



## 2<sup>nd</sup> Yet Another Discrete Element Workshop

*Discrete-based modeling of multi-scale coupled problems*

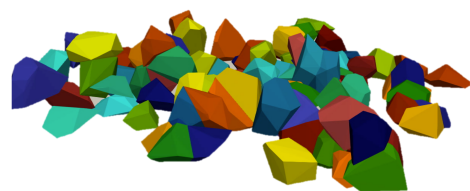
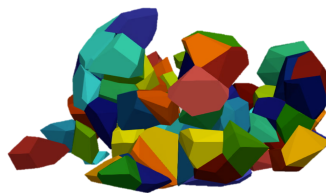
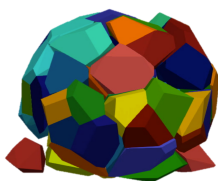
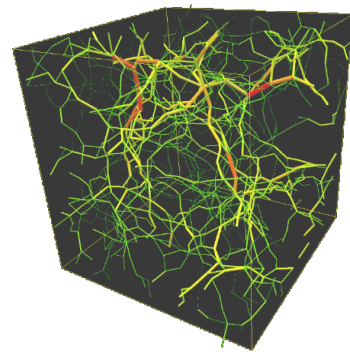
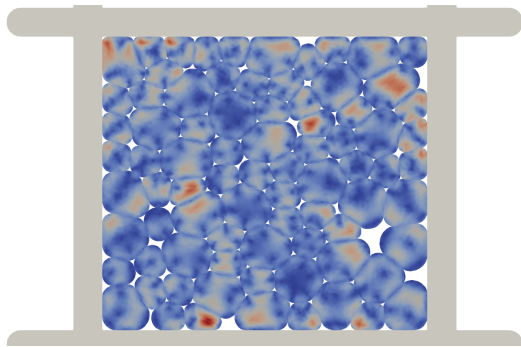
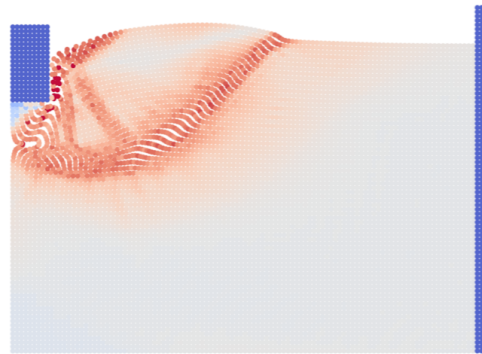
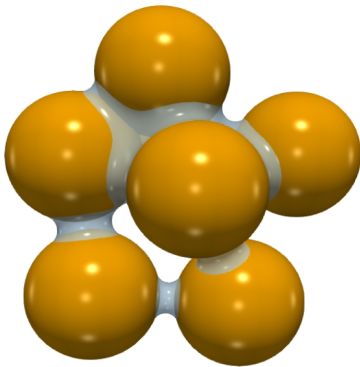

Aix-en-Provence, France, April 26–27, 2018

2<sup>nd</sup> YADE Workshop: Discrete-based modeling of multi-scale coupled problems  
Booklet of Abstracts  
ISBN 979-10-94074-06-0

Cover page images (from left to right, top to bottom) taken from

- E. P. Montellà et al. (University Grenoble Alpes ; Technical University of Catalonia)
- J. Zhao (Hong Kong University of Science and Technology ; HKUST Shenzhen Research Institute)
- T. L. Vu et al. (LMGC, Univ. Montpellier, CNRS)
- C. Thornton et al. (University of Birmingham ; Universidad Nacional de San Juan ; Newcastle University)
- L. F. Orozco et al. (LMGC, Univ. Montpellier, CNRS ; UMI 3466 CNRS-MIT, CEE, MIT ; INRA, UMR IATE ; CEA, DEN, DEC, SFER, LCU)

, this volume

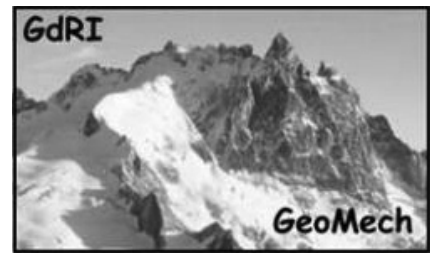

## 2<sup>nd</sup> Yet Another Discrete Element Workshop

*Discrete-based modeling of multi-scale coupled problems*

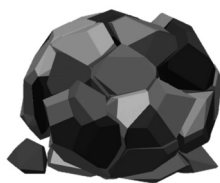
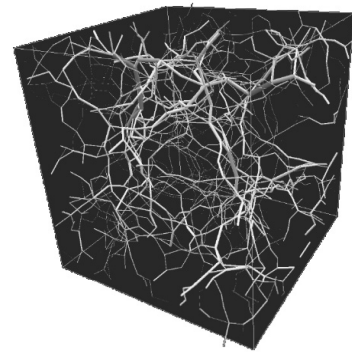
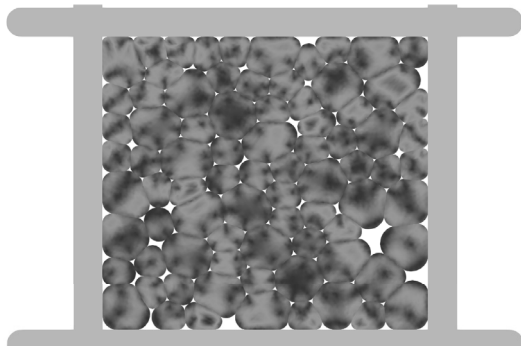
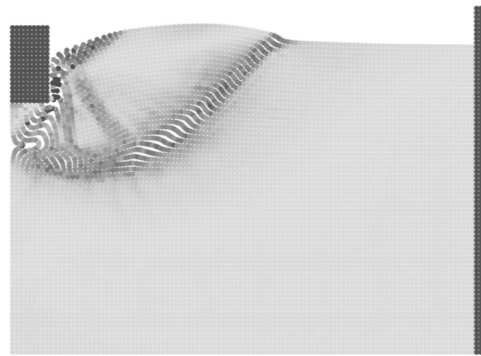
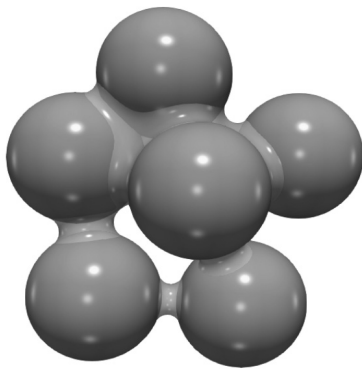

Aix-en-Provence, France, April 26–27, 2018



The present booklet includes the abstracts for the 4 keynote lectures and 34 regular talks delivered during the 2<sup>nd</sup> Yet Another Discrete Element Workshop *Discrete-based modeling of multi-scale coupled problems* that took place in Aix-en-Provence (France), on April 26–27, 2018.

Following a first edition in Grenoble University in 2014, we hope this 2<sup>nd</sup> YADE workshop starts the tradition of informal scientific events dedicated to numerical modeling approaches that are based on the Discrete Element Method (DEM). Gathering a very wide community of DEM users and developers, as shown in the Figure below, we also hope this workshop could be the place for a (respectful !) comparison of practices and that technical aspects will not be left over.

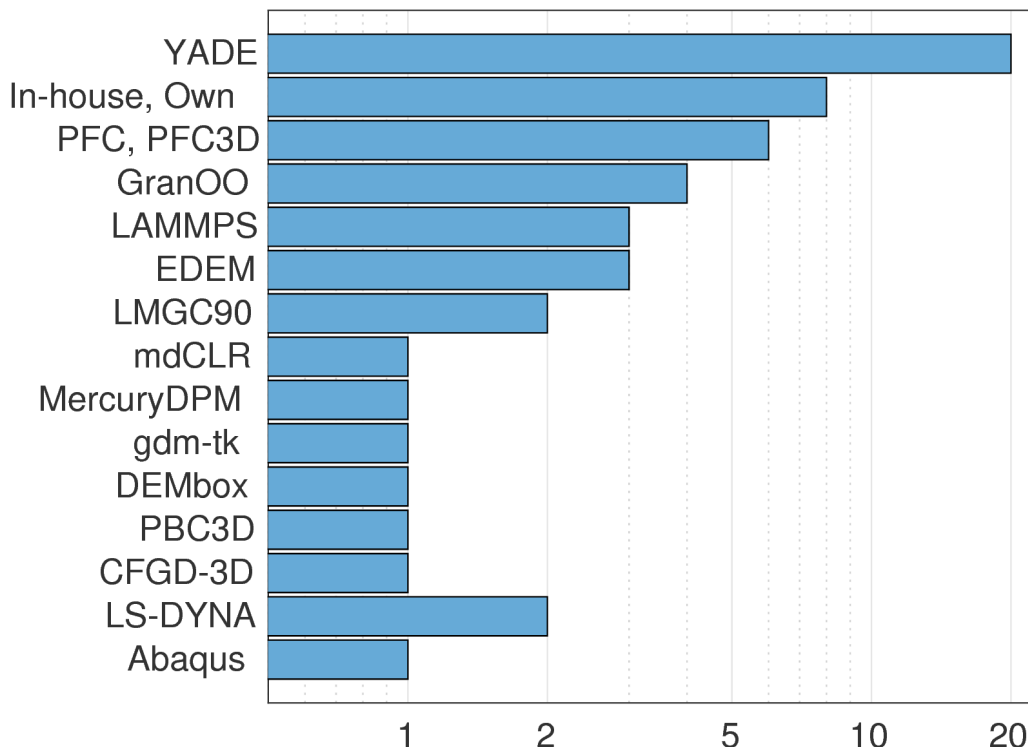

**Figure** DEM and FEM codes used by a sample of 40 participants to the workshop. Each participant may use several codes, the count of code uses is depicted along a logarithmic scale

Inspired by the free, open-source, YADE code (<https://yade-dem.org/>), the workshop has welcomed more than 70 international researchers and scientists free of charge, thanks to the full support of the French research institute IRSTEA, through its local RECOVER unit (<http://www.irstea.fr/en/research/research-units/recover>), in collaboration with the international research network GeoMech (<http://gdr-mege.univ-lr.fr/>). In case of institutional GeoMech members, one night accommodation in Aix-en-Provence also has been provided to the participants.

We trust this financial commitment enabled fruitful scientific discussions and will foster new and long-lasting collaborations in various fields relying on DEM-based numerical simulations.

Lastly, we would like to thank the keynote speakers for accepting our invitation, the authors for accommodating short time slots for their oral

presentations, and all participants for attending the workshop whether they came directly from Aix-en-Provence, or from North and South America, Australia and South Korea.

Jérôme Duriez (IRSTEA) Chairman of the Organizing Committee  
of the 2<sup>nd</sup> YADE workshop  
<https://2ndyadeworkshop.sciencesconf.org/>

Organizing Committee:

- Jérôme Duriez (IRSTEA)
- Christophe Bouillon (IRSTEA)
- Stéphane Bonelli (IRSTEA)
- Dominique Breil (IRSTEA)
- Naim Chaouch (IRSTEA)
- Vincent Garnier (Aix-Marseille University)
- Olivier Millet (La Rochelle University)
- François Nicot (IRSTEA)
- Laurent Peyras (IRSTEA)
- Pierre Philippe (IRSTEA)

## Table of Contents

### Keynote lectures

---

Hierarchical multiscale modeling of granular media: the good, the bad and the ugly	5
J. Zhao .....	5
Collapse of a water-saturated granular column in air	7
P. Aussillous and C. Nobili .....	7
Coupling DEM and fluids at the pore scale: recent advances and further issues	8
B. Chareyre, Y. Chao, E.P. Montella, S. Salager and A. Gens.....	8
From discrete particle micromechanics towards continuum theory	10
S. Luding .....	10

### DEM micro-mechanics of discrete materials

---

Modelling of flexible composite structures in YADE with an example in rockfall protection	11
K. Thoeni, A. Effeindzourou and A. Giacomini .....	11
Multi-scale analysis of failure in highly porous cohesive granular materials	13
T. Mede, G. Chambon, P. Hagenmuller and F. Nicot .....	13
Discrete modeling of clay as a micro-granular assembly of platelets	15
K. Lampoh, V. Richefeu, Y. F. Dafalias and F. Radjai.....	15
Micro-mechanical investigation of the effect of fine content on mechanical behavior of gap graded granular materials using DEM	17
N.-S. Nguyen, H. Taha, D. Marot, A. Hijazi and K. Abou-Saleh.....	17
Statistical Analysis of Stress in Wet Granular Materials	19
R. Wan, M. Pouragha and J. Duriez.....	19
3D simulations of the granulation of wet granular materials	20
T.-T. Vo, P. Mutabaruka, S. Nezamabadi, J.-Y. Delenne and F. Radjai.....	20
Elasticity and decomposition of strain in granular materials	22
M. Pouragha and R. Wan .....	22
Microscopic features of liquefaction	23
C. Thornton, E. Martin and S. Utili.....	23

### Grain crushing, and severe deformation, in DEM

---

Evolution of strength and structure of crushable grain assemblies	25
D. Cantor, E. Azéma, P. Sornay and F. Radjai .....	25
Dynamic fragmentation of grains under impact	26
L. F. Orozco, J.-Y. Delenne, P. Sornay and F. Radjai.....	26
Experimental and numerical investigation of highly deformable particle systems	28
T.-L. Vu, J. Barés, S. Nezamabadi and S. Mora .....	28
Modeling deformable granular materials using Material Point Method	29
S. Nezamabadi, T. H. Nguyen, J.-Y. Delenne and F. Radjai .....	29

### Coupled DEM simulations

---

Numerical and experimental modeling of cemented soils	30
P. Philippe, F. Brunier-Coulin, Z. Benseghier, P. Cuéllar, J.-Y. Delenne and S. Bonelli.....	30
Use of DEM-LBM modeling to prove the relevance of free jet model for soil erosion by impinging jet	32
Z. Benseghier, P. Cuéllar, L.-H. Luu, J.-Y. Delenne, S. Bonelli and P. Philippe.....	32
Multiscale numerical investigation of cover-collapse sinkhole in cohesive soils	34
L.-H. Luu, P. Philippe and G. Noury .....	34
Micromechanical study of multiphase flow based on the lattice Boltzmann method	36
E. P. Montellà, B. Chareyre, S. Salager and A. Gens .....	36



DEM-RANS coupling with YADE: presentation and application to turbulent bedload transport	
R. Maurin, J. Chauchat and P. Frey .....	38
YADE simulations of vertical size-segregation in bedload sediment transport	
R. Chassagne, P. Frey, J. Chauchat and R. Maurin.....	40
Simulation of Dense Granular Suspension	
L. Amarsid, J.-Y. Delenne, Y. Monerie, F. Perales and F. Radjai .....	42
Suffusion micro-mechanisms through DEM/PFV simulations	
A. Wautier, F. Nicot and S. Bonelli .....	43
DEM model and Suffusion-like Simulations	
R. Aboul Hosn, L. Sibille, N. Benahmed and B. Chareyre .....	44
Heat conduction in polydisperse granular media	
D. H. Nguyen, B. Collard, É. Azéma, P. Sornay and F. Radjai .....	45
Combined DEM-FEM Modeling of Shot Peening Process	
D. Bobba, P. Ramaprabhu and H. P. Cherukuri .....	46

### **DEM hydro-mechanical modeling of rock and concrete**

---

DFNFlow Engine: Hydraulic fracturing and progressive failure in saturated low permeability quasi brittle materials	
E. Papachristos, L. Scholtès, F. Donzé and B. Chareyre .....	48
Modelling of hydraulic fracturing in rocks using VPN fluid flow model in coupled DEM/CFD approach	
M. Krzaczek, J. Kozicki and J. Tejchman.....	50
Micromechanical modeling of acoustic emissions using strain energy and numerical wave propagation in heterogeneous rocks	
R. Caulk .....	52
DEM and FEM Modeling of Uniaxial and Triaxial Compressive Behavior of Plain Concrete	
A. Joshi, N. Tannu, R. Aguilar, H. P. Cherukuri and M. A. Pando .....	54
Numerical Investigation of Earthquake Rupture and Off-Fault Fracture Response with a Coupled Discrete-Continuum environment	
S. Emam, C. Darcel, M. H. Tran and J. Suikkanen .....	56
Assessing the hydromechanical properties along a listric fault, using DEM modelling	
V. Girardi, F.-V. Donzé and P. Simonini .....	57

### **Making DEM life easy : parameters' calibration and computational cost**

---

A Bayesian calibration toolbox for YADE	
H. Cheng, T. Shuku, K. Thoeni, P. Tempone, S. Luding and V. Magnanimo .....	59
A direct calibration method for cohesive beam bond models	
D. André, T. T. Nguyen and M. Huger .....	61
Genetic programming applied to DEM calibration	
M. De Simone, M. G. Filho, L. M. S. Souza, F. L. G. Pereira and D. Roehl.....	62
Timing comparison between two different approaches for wire mesh modelling	
A. Pol, F. Gabrieli and K. Thoeni.....	64
Building a high performing GPU accelerated Yade PFV computer at low cost	
R. Caulk .....	66

# Hierarchical multiscale modeling of granular media: the good, the bad and the ugly

Jidong Zhao<sup>1,2</sup>

<sup>1</sup> Hong Kong University of Science and Technology

<sup>2</sup> HKUST Shenzhen Research Institute  
jzhao@ust.hk

**Keywords:** Granular media; computational multiscale modeling; hierarchical coupling scheme; FEM  $\times$  DEM; MPM  $\times$  DEM

Hierarchical multiscale modeling provides a viable computational framework to solve engineering-scale boundary value problems (BVPs) for granular media without having to presume complex phenomenological constitutive models (Guo & Zhao, 2014, 2016a,b,c; Desrues et al., 2015). The framework typically consists of a continuum simulation tool that can effectively tackle the macro domain of a BVP under complex boundary/initial conditions, and a discrete-based method that suits well for describing the discrete nature of granular particles at the grain scale and for solving a meso-scale representative assembly (RVE) of them. The hierarchical coupling between the macro and meso scales is furnished through two-way information passing mechanisms that feed necessary solutions from one scale to drive the computations of the other. A typical workflow for HMM is demonstrated in Figure 1 where the continuum simulation method can be the classic FEM (Finite Element Method) or popular recent ones such as MPM (Material Point Method), and the discrete-based tool can be DEM (Discrete Element Method) or Peridynamics. HMM has witnessed increasing popularity in the community of geomechanics in the past decade. A brief review is devoted in this paper to the developments and status quo of HMM in granular media studies. The benefits one may gain from HMM of granular media and the pros and cons of specific coupling schemes in tackling different problems will be summarized. Special focuses will be placed on the major hurdles and challenges we have to address and related strategic directions we may strive to explore, in order to fully unleash the potentials of HMM to tackle a wider range of problems for a broader class of materials beyond geomechanics.

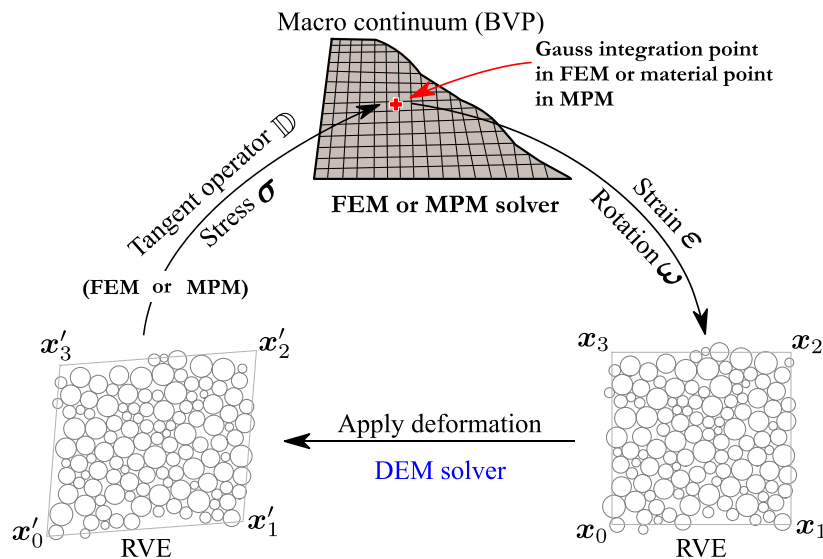

**Figure 1** Hierarchical multiscale modeling (HMM) of granular media based on coupled FEM or MPM with DEM

Discussion will encompass the following sub-topics on hierarchical multiscale modeling of granular media: (1) RVE characterization and selection (Shahin et al. 2016); (2) rigorous micromechanical modeling of fully and partially saturated granular media (Guo & Zhao, 2016a);

(3) grain morphology and crushing; (4) large deformation modeling (Liang & Zhao, 2018); (5) Integrated hierarchical/concurrent multiscale modeling for transition from continuum-discontinuum transitions; (6) fully dynamic multiscale modeling of geomechanics problems; (7) data-driven multiscale modeling in geomechanics. For example, though the existing HMM based on coupled FEM  $\times$  DEM (Guo & Zhao, 2014, 2016b) may partially account for large strain and large rotation, it has to resort to various remeshing and remapping techniques to solve the mesh distortion issue at very large deformation, e.g., in a footing problem (Figure 2a, Guo & Zhao, 2016b). If a coupled MPM  $\times$  DEM scheme is employed, HMM may capture the large deformation/distortion more effectively and robustly (Figure 2b, Liang & Zhao, 2018).

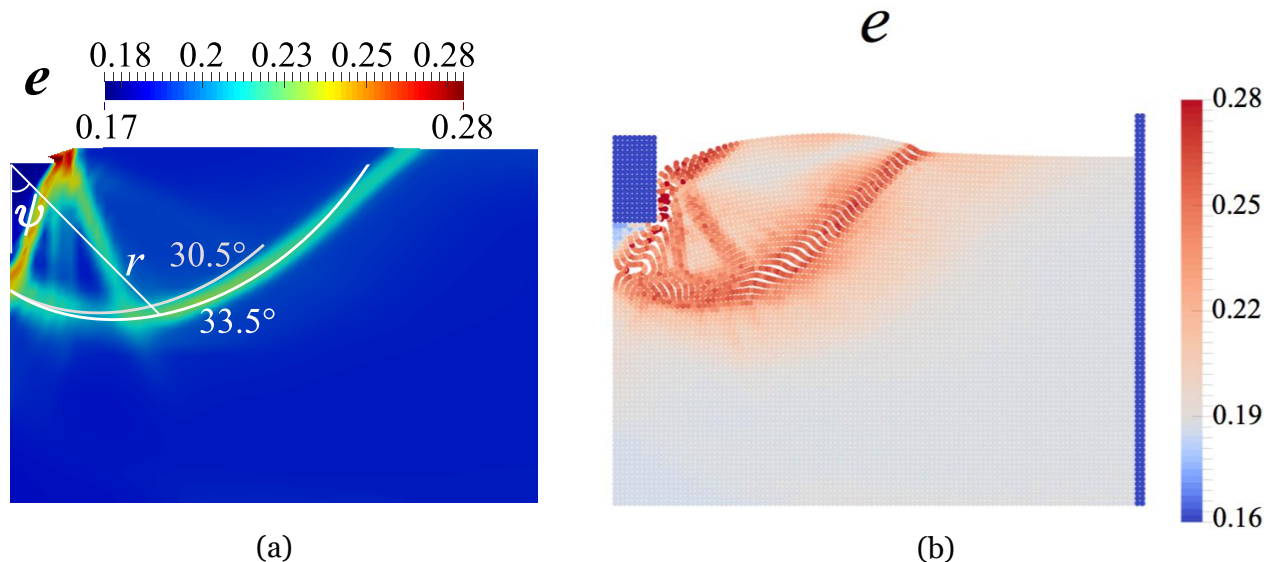

**Figure 2** Hierarchical multiscale modeling of general failure modes (per void ratio) of a footing on sand: (a) by FEM  $\times$  DEM (Guo & Zhao, 2016b); (b) by MPM  $\times$  DEM (Liang & Zhao, 2018).

## References

- Desrues J, Nguyen TK, Combe G, Caillerie D (2015) FEM  $\times$  DEM Multi-scale Analysis of Boundary Value Problems Involving Strain Localization. In K. Chau & J. Zhao (eds): *Bifurcation and Degradation of Geomaterials in the New Millennium*. Springer Heidelberg, Berlin, Germany. pp. 259–265.
- Guo N. and Zhao J.D. (2014) A coupled FEM/DEM approach for hierarchical multiscale modelling of granular media. *Int. J. Numer. Methods Eng.* 99:789–818.
- Guo N. and Zhao J.D. (2016a). Parallel hierarchical multiscale modelling of hydro-mechanical problems for saturated granular soils. *Computer Methods in Applied Mechanics and Engineering* 305: 37-61.
- Guo N. and Zhao J.D. (2016b). Multiscale insights into classical geomechanics problems. *Int. J. Numer. Anal. Methods Geomech.* 40(3): 367-390.
- Guo N, Zhao J.D. and Sun W.C. (2016c) Multiscale analysis of shear failure of thick-walled hollow cylinder in dry sand. *Géotechnique Lett.* 6:77–82.
- Liang W. and Zhao J.D. (2018). Multiscale modeling of large deformation in geomechanics. To be submitted to *Int. J. Numer. Anal. Methods Geomech.*
- Shahin G., Desrues J., Pont S.D., Combe G. and Argilaga A. (2016) A study of the influence of REV variability in double-scale FEM  $\times$  DEM analysis. *Int. J. Numer. Meth. Engng.* 107: 882-900.

## Acknowledgements

The author acknowledges financial supports from National Science Foundation of China under Project No. 51679207, Research Grants Council of Hong Kong under GRF Project N. 16210017 and a Theme-based Research Project No. T22-603/15N.

# Collapse of a water-saturated granular column in air

Pascale Aussillous<sup>1</sup>, Clément Nobili<sup>2</sup>

<sup>1</sup> Aix Marseille Univ, CNRS, IUSTI, Marseille, France

<sup>2</sup> Aix Marseille Univ, CNRS, IRPHE, Marseille, France  
pascale.aussillous@univ-amu.fr

**Keywords:** granular media; fluid/particle flow

We study experimentally the collapse of a granular column saturated with water. The granular column is initially stabilized by an air interface with an imposed Laplace pressure difference. We study the dynamics of the column when the Laplace pressure suddenly vanishes. The collapse is initiated either by a light knock, imposing the volume of water constant, or by imposing a constant positive fluid pressure.

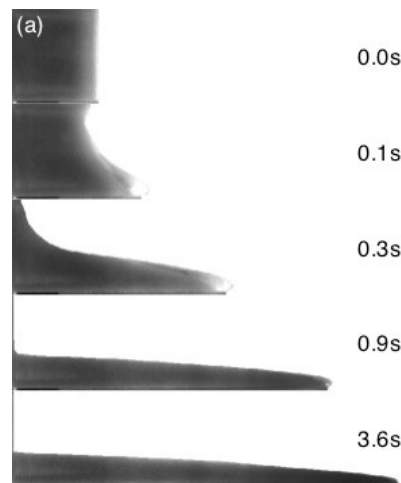

**Figure 1** Collapse of an initially loose water-saturated granular column

Similarly to the collapse of a fully immersed granular column (Rondon et al., 2011), the morphology of the deposit is mainly controlled by the initial volume fraction of the granular mass. Different regimes are identified according to the initial packing and the way the collapse is initiated. The initial loose packed columns give long and thin deposits with a fast dynamic that do not seem to depend on the collapse initiation (Figure 1). For dense packing, no motion is seen when the volume of water is kept constant, whereas the slow dynamics seem to depend on the imposed fluid pressure.

We compare the results to a depth-averaged two-phase continuum model, having a frictional rheology to describe particle-particle interactions (Ouriemi et al., 2009.; Boyer et al., 2011), and taking into account the mechanisms of dilatancy (Pailha et al., 2009), which can capture most of the experimental observations for the collapse of fully submerged granular columns.

## References

- Boyer F. and Guazzelli E. (2011) Unifying suspension and granular rheology, *Phys. Rev. Lett.* 107, 188301.
- Ouriemi, M., Aussillous P. and Guazzelli E. (2009) Sediment dynamics. Part 1. Bed-load transport by laminar shearing flows, *J. of Fluid Mech.* 636, 295-319.
- Pailha, M. and Pouliquen O. (2009) A two-phase flow description of the initiation of underwater granular avalanches. *J. Fluid Mech.* 633, 115–135.
- Rondon L., Aussillous P. and Pouliquen O. (2011) Granular collapse in a fluid: role of the initial volume fraction, *Phys. Fluids* 23, 073301.

## Coupling DEM and fluids at the pore scale: recent advances and further issues

Bruno Chareyre<sup>1</sup>, Yuan Chao<sup>1</sup>, Eduard Puig Montella<sup>1,2</sup>, Simon Salager<sup>1</sup>, Antonio Gens<sup>2</sup>

<sup>1</sup> Université Grenoble Alpes, Grenoble INP, 3SR lab., 38041, France

<sup>2</sup> Technical University of Catalonia (UPC), 08034, Barcelona, Spain  
bruno.chareyre@3sr-grenoble.fr

**Keywords:** seepage flow, capillarity, hydro-mechanical coupling, pore scale

Simulating complex hydro-mechanical couplings in large grain-fluid systems is a great challenge for the discrete element methods (DEM). For materials saturated by only one pore fluid, recent advances in pore-scale methods in which the porosity is discretized as a network of connected pores (Chareyre et al. 2012) enabled the resolution of large coupled problems in three dimensions. These methods can reflect the dominant viscous terms at the particle scale without actually solving a Navier-Stokes problem (Marzougui et al. 2015). The computational cost is thus reduced by orders of magnitudes, which opens up more realistic simulations - as illustrated by a few recent examples. In this presentation the following question is examined: can the pore-scale approach be extended to multiple (two) immiscible pore fluids to simulate the so-called unsaturated materials?

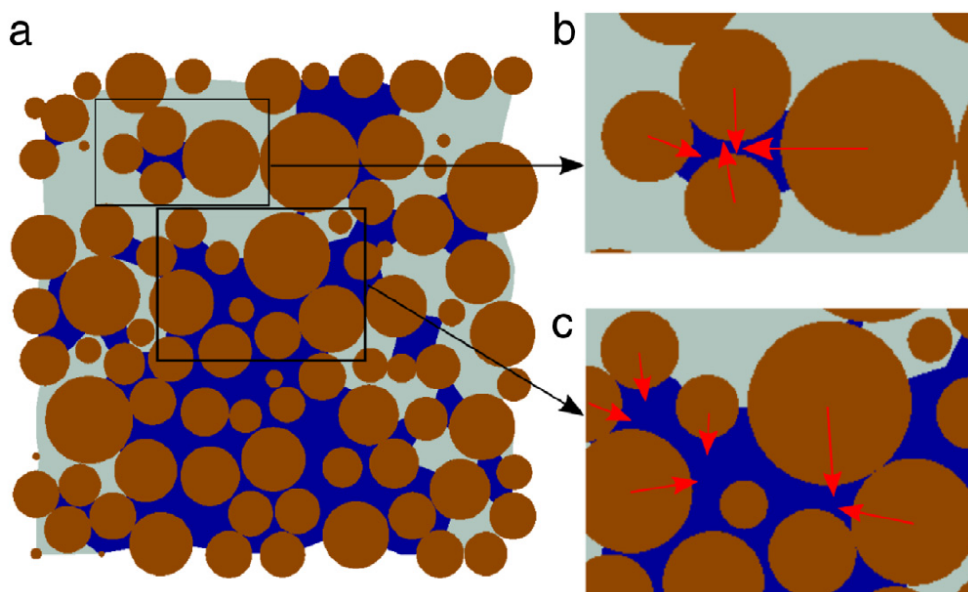

**Figure 1** (a) Distribution of the wetting phase (dark blue) and the non-wetting phase (light blue) during the primary drainage of a 3D sphere packing, simulated with the pore-scale model of Yuan and Chareyre (2017); (b,c) the red arrows indicate the capillary forces on individual particles.

Numerical models of partially saturated granular materials based on the DEM have been used extensively, yet the majority of them are strongly limited to the so-called pendular regime in which the wetting phase is present in such a little amount that it only forms pendular bridges associated to pairs of particles. In the other saturation regimes one hardly avoid time consuming surface minimization techniques or even the direct resolution of a 2-phase fluid dynamics problem at the microscale to capture the geometry of phases and interfaces. The pore-scale approach of this problem aims at a drastic decrease of this computational cost. We show how the movements of the fluid phases and the fluid-solid interactions can be described by introducing relevant geometrical

objects in a tetrahedrized granular domain, together with evolution laws. For a range of micro-scale processes this approach is successful and for instance, the primary drainage of a saturated sample can be reproduced accurately (Yuan et al. 2016). Unfortunately, a number of processes remain which still need significant efforts from both phenomenological and algorithmic points of view, such as bubble entrapment, coalescence of wetting phases, or viscous effects leading to mixed scenario of drainage-imbibition at the local scale.

A general framework is proposed in which the zoology of the pore-scale objects and their behavior is improved with the help of direct simulations with the Lattice-Boltzman method (LBM – see Montella et al. (2018)). Domain decomposition applied to a large granular specimen lets one identify relevant elementary units of the micro-structure made of less than a dozen particles typically. The LBM responses of these elementary units under particular boundary conditions are used to assemble a global two-phase flow problem to be solved by a pore-network solver, in a multiscale coupling. The numerical framework is evolutionary in the sense that the results it produces may help developing progressively analytical relationships between the hydrostatic properties of the elementary structures (such as the threshold values of capillary pressure for drainage/imbibition of one pore) and their geometrical parameters. Ultimately, the LBM resolution may only be required for a selection of subdomains where the process is too complex, while the evolution of the fluid phases in the most conventional subdomains would be entirely governed by analytical laws.

## **References**

- Chareyre, B., Cortis, A., Catalano, E., & Barthélemy, E. (2012). Pore-scale modeling of viscous flow and induced forces in dense sphere packings. *Transport in porous media*, 94(2), 595-615.
- Marzougui, D., Chareyre, B., & Chauchat, J. (2015). Microscopic origins of shear stress in dense fluid–grain mixtures. *Granular Matter*, 17(3), 297-309.
- Montella, E.P., Chareyre, B., Salager, S., & Gens, A. (2018) *Micromechanical study of multiphase flow based on the lattice Boltzmann method*, 2<sup>nd</sup> Yade Workshop.
- Yuan, C., Chareyre, B., & Darve, F. (2016). Pore-scale simulations of drainage in granular materials: finite size effects and the representative elementary volume. *Advances in Water Resources*, 95, 109-124.
- Yuan, C., & Chareyre, B. (2017). A pore-scale method for hydromechanical coupling in deformable granular media. *Computer Methods in Applied Mechanics and Engineering*, 318, 1066-1079.

## **Acknowledgements**

The first autor is grateful for the invitation to discuss this work at the 2<sup>nd</sup> Yade Workshop and he would like to thank IRSTEA and especially Jérôme Duriez for triggering and organizing this event.

# From discrete particle micromechanics towards continuum theory

Stefan Luding

Multiscale Mechanics (MSM), Faculty of Engineering Technology (ET), MESA+  
POBox 217, 7500 AE Enschede, Netherlands (<http://www2.msm.ctw.utwente.nl/sluding/>)  
s.luding@utwente.nl

**Keywords:** Particle simulations; Micro-macro; continuum theory of powders & granular matter

The dynamic behavior of particulate and granular matter – like sand, powder, suspended particles or molecules, often with a wide distribution of particle sizes – is of considerable interest in a wide range of industries and research disciplines since they can behave both solid-like and fluid-like. The related mechanisms/processes in particle systems are active at multiple scales (from nano-meters to meters), and finding the reasons for, e.g., natural disasters like avalanches or plant problems like silo-failure, is an essential challenge for both academia and industry.

In order to understand the fundamental micro-mechanics one can use particle simulation methods, where often the fluid between the particles is important too. However, large-scale applications (due to their enormous particle numbers) have to be addressed by coarse-grained models or by continuum theory. In order to bridge the gap between the scales, so-called micro-macro transition methods are necessary, which translate particle positions, velocities and forces into density-, stress-, and strain-fields. These macroscopic quantities must be compatible with the conservation equations for mass and momentum of continuum theory. Furthermore, non-classical fields are needed to describe the micro-structure (fabric, force-chains) or the statistical fluctuations, e.g. of the kinetic energy, before one can reach the ultimate goal of solving application problems.

Examples of multi-scale simulations, involving particle- and continuum-methods, are flows of particles/fluids in narrow channels/pores, dosing of cohesive fine powders in vending machines, avalanche flows on inclined slopes, segregation, rheology testing in ring-shear cells, as well as the study of non-linear elasto-plastic material mechanics related to the stability/failure of cohesive, frictional solids (Kumar et al., 2014 ; Singh et al., 2014, 2015 ; Roy et al., 2017).

## References

- N. Kumar, S. Luding and V. Magnanimo (2014) Macroscopic model with anisotropy based on micro-macro informations, *Acta Mechanica* 225:8, 2319–2343
- S. Roy, S. Luding and T. Weinhart (2017) A general(ized) local rheology for wet granular materials, *New J. Phys.* 19, 043014
- A. Singh, V. Magnanimo, K. Saitoh and S. Luding (2014) Effect of cohesion on shear banding in quasi-static granular material, *Phys. Rev. E* 90(2), 022202
- A. Singh, K. Saitoh, V. Magnanimo and S. Luding (2015) Role of gravity or confining pressure and contact stiffness in granular rheology, *New J. Phys.* 17, 043028

# Modelling of flexible composite structures in YADE with an example in rockfall protection

Klaus Thoeni, Anna Effeindzourou, Anna Giacomini  
 Centre for Geotechnical Science and Engineering  
 The University of Newcastle, Callaghan, NSW 2308, Australia  
 klaus.thoeni@newcastle.edu.au

**Keywords:** Geosynthetics; Membrane; Wire mesh; Deformable element; Minkowski sum;

Flexible structures are very common in geotechnical engineering. For instance, geogrids and geomembranes are used for ground improvement whereas metallic wire meshes are usually used for slope stabilization and rockfall protection. In some cases, geotextiles are also combined with metallic wires to build elements (e.g., cylinders, cubes) that are filled with granular material. This work presents a framework for the modelling of such composite structures.

First, the classical approach for the discrete modelling of flexible structures is discussed. This consists of bonding spheres, where spheres can either be in contact or not. The latter is known as remote interaction approach and it is generally used to model wires (Thoeni et al., 2013). Nevertheless, the main drawback is that no physical element is representing the wire. This can be overcome by introducing cylinder elements which connect the physical nodes. An approach using the Minkowski sum of a line segment has been proposed by Bourrier et al. (2013) for the modelling of plant roots. The model was further extended by Effeindzourou et al. (2016) to account for grids or interconnected cylinders and membrane elements, so-called PFacets. This approach is discussed in detail and it is shown how it can be used to model a composite structure made of a wire mesh, steel rings and a geomembrane. Figure 1a shows the general concept where the wire mesh and the steel ring are represented by cylinders. In addition to the cylinder elements, Pfacet elements are generated in the mesh openings to represent the geotextile (Figure 1b). Finally, the cylindrical structure is filled with granular material (Figure 1c).

Experimental tests of an impacting boulder are used to calibrate the numerical model. Once calibrated, the capabilities of the model are presented and discussed in detail.

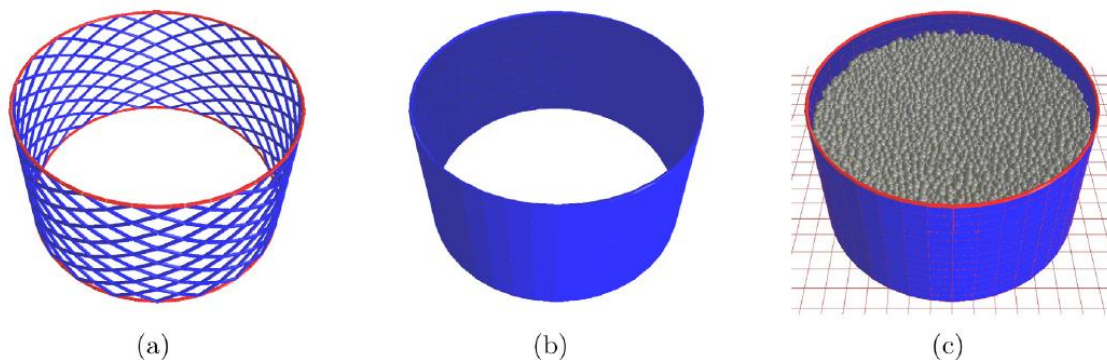

**Figure 1** Numerical representation of the composite rockfall protection structure: (a) wire mesh, (b) geotextile, and (c) with granular material filled composite structure (after Effeindzourou et al., 2017).

## References

- Bourrier F., Kneib F., Chareyre B. and Fourcaud T. (2013) Discrete modeling of granular soils reinforcement by plant roots, *Ecological Engineering*, 61:646–657
- Effeindzourou A., Chareyre B., Thoeni K., Giacomini A. and Kneib F. (2016) Modelling of deformable structures in the general framework of the discrete element method, *Geotextiles and Geomembranes* 44(2), 143–156



Effeindzourou A., Thoeni K., Giacomini A. and Wendeler C. (2017) Efficient discrete modelling of composite structures for rockfall protection, *Computers and Geotechnics* 87, 99–114

Thoeni K., Lambert C., Giacomini A. and Sloan, S.W. (2013) Discrete modelling of hexagonal wire meshes with a stochastically distorted contact model, *Computers and Geotechnics* 49, 158–169

### ***Acknowledgements***

The author would like to acknowledge the financial support by the Australian Coal Association Research Project.

# Multi-scale analysis of failure in highly porous cohesive granular materials

Tijan Mede<sup>1</sup>, Guillaume Chambon<sup>1</sup>, Pascal Hagenmuller<sup>2</sup>, François Nicot<sup>1</sup>

<sup>1</sup> University Grenoble Alpes, Irstea, 2 Rue de la Papeterie, 38402, Saint-Martin-d'Hères, France

<sup>2</sup> Météo France – CNRS, CNRM, CEN, 1441 Rue de la Piscine, 38400 Saint-Martin-d'Hères, France  
tijan.mede@irstea.fr

**Keywords:** Irregular grain; DEM; Snow; Porous

Weak snow layers are thin layers of low density and cohesion that consist of a complex network of sintered ice grains. Although the failure and collapse of these fragile layers is considered to be the primary cause of dry slab snow avalanche release, their mechanical behavior remains poorly understood.

The response of these layers to mechanical loading has been modelled with an original approach based on YADE software, using x-ray tomographical images of real snow samples as input data on the microstructure of the material (Mede et al. (2017), Mede et al. (2018)). The method enables the study of microscopic mechanisms of failure as well as the effect of microstructure on the macroscopic properties of the material.

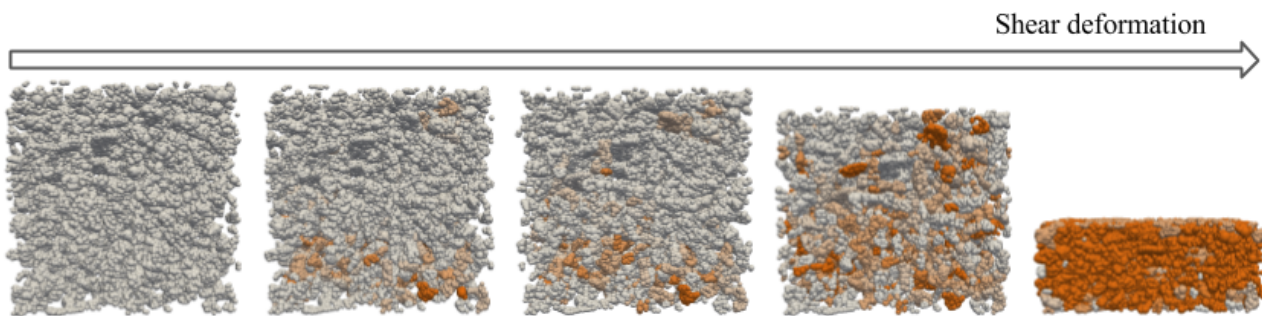

**Figure 1** Progressive collapse (from left to right) in a specimen during direct shear simulation with imposed normal stress. The orange color represents damage in the form of broken cohesive bonds.

The tomographical image of snow is divided into individual grains by detecting weak mechanical points i.e. neck regions in the snow matrix. Following the hypothesis of grain bond fracturing being the governing deformational mechanism within the material, these grains are modelled as the basic elements of the simulation, as separate unbreakable entities, which are sintered into the original matrix of intact snow. An original method for representing irregular grain shapes in the DEM is then introduced. The method is based on utilizing the medial axis concept to represent an arbitrary grain shape with an optimal set of overlapping spheres. A novel approach was also developed to connect these grains into the snow matrix via cohesive bonds with the neighbouring grains.

A thorough study of the effect of the grain approximating technique parameters on the key geometrical features of the grains is then carried out. Finally, the functionality of the model is demonstrated by performing mechanical tests on an image of a real snow sample. Systematically performing the mechanical tests with different combinations of values of grain approximating parameters enabled us to find an optimal grain approximation that enabled accurate mechanical results at a reasonable computational price. In addition, the effect of geometrical descriptors of approximated grains on the mechanical simulations was observed.

In conclusion we will show the macroscopic and microscopic features of sample deformation and collapse that can be obtained with the presented DEM simulation. In addition to macroscopic stress-strain curve, strain localization patterns, damage progression and the evolution of force chain network in the specimen can be observed.

## **References**

- Mede, T., Chambon, G., Hagenmuller, P., Nicot, F. (2018) “A medial axis based method for irregular grain shape representation in DEM simulations”, *Granular Matter* 20:1, 16
- Mede, T., Chambon, G., Hagenmuller, P., Nicot, F. (2017) “Mechanical behaviour of weak snow layers: modelling a porous structure of sintered grains” in *Proceedings of Powders and Grains*, 3-7.7.2017, EPJ Web of Conferences 140, 06008

## **Acknowledgements**

This project is Funded by Labex TEC21 (Investissements d’Avenir, Grant agreement ANR-11-LABX-0030).

# Discrete modeling of clay as a micro-granular assembly of platelets

Komlanvi Lampoh<sup>1</sup>, Vincent Richefeu<sup>2</sup>, Yannis F. Dafalias<sup>3</sup>, Farhang Radjai<sup>4</sup>

<sup>1</sup> INRA-Institut National de la Recherche Agronomique, (UMR, IATE), France

<sup>2</sup> Laboratoire 3SR -Sols, Solides, Structures - Risques, UMR 5521, France

<sup>3</sup> Department of Civil and Environmental Engineering, University of California, USA

<sup>4</sup> Laboratoire de Mécanique et Génie Civil, UMR 5508, France  
komlanvi.lampoh@inra.fr

**Keywords:** clay aggregates; Lennard-Jones potential; isotropic compaction; nematic ordering

The studies presented herein concern clay fabric evolution during deformation using DEM approach. The objective is to enrich existing rheological models considering clay fabric effect. At the nanoscale, clay particles interact through double-layer potential energy (Cygan et al, 2004), (Laird, 2006). The key step in DEM simulations of the mechanical response of clay under deformation due to various loading paths is the choice of appropriate approximation of local interactions so that a representative volume element with large number of platy-shaped particles can be simulated. In other words, a trade-off is necessary between the accuracy of the physical model at the scale of particles and their interactions on one hand, and the number of particles, on the other hand. For this purpose, an analytical form of point-wise repulsive and attractive interaction potentials was used together with a numerically efficient integration scheme of forces acting between the particles. This trade-off is all the more crucial that, even in the absence of attraction forces, long-range correlations and nematic ordering is induced by anisometric shapes of the particles, the particles tending to align themselves along their longest axes. The inclusion of colloidal forces has profound effects on the structures by enhancing particles clustering into layers and aggregates (figure 1).

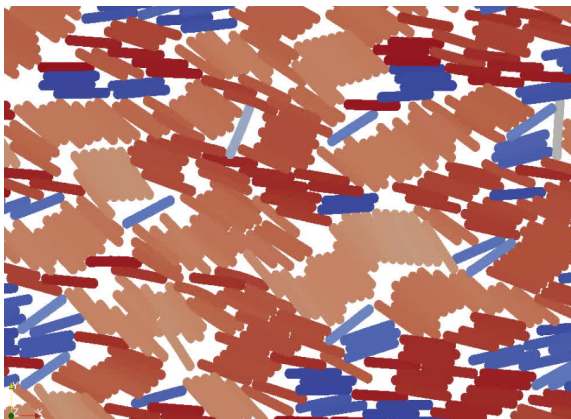

**Figure 1** Clustering of 2D platelets under shear loading. The colors indicate different platelet orientations.

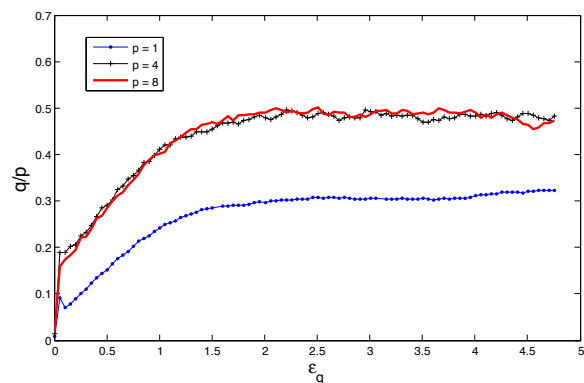

**Figure 2** Shear loading for 3 different values of the confining dimensionless pressure ( $p=1,4,8$ ).

This local ordering is used to define or identify the aggregates. The inter-aggregate fabric is then determined from the orientations of the aggregates and their interactions. The particles are modelled as chains of several sites each with an effective radius. These forms avoid complications of contact detection between non-spherical particles. The interaction potential between sites is of Gay-Berne type with an attraction part reminiscent of the Lennard-Jones potential and a repulsive electric part. The numerical samples are prepared by isotropic compaction with different values of the consolidation stress. The clustering state of the sample, i.e. the proportion of bonded particles, and initial void ratio are controlled by this stress. Then different loading paths and directions are

applied to drive the material towards or away from the critical state (Figure 2), including loading directions different from fabric orientation. Fully periodic boundary conditions are used in order to avoid wall effects and shear localization (Radjai & Dubois, 2011). A parametric study is performed of the evolution of fabric parameters (intensity, orientation), void ratio and stress and strain parameters (stress ratios, principal directions, dilatancy) at different scales, identifying aggregates and their sizes and shapes, fabric differentiated according to the geometry of contact.

### **References**

- Randall T. Cygan, Jian-Jie Liang, and Andrey G. Kalinichev. Molecular models of Hydroxide, Oxhydroxide, and clay phases and the Development of a General Force Field. *The Journal of Physical Chemistry B*, 108(4):1255-1266, 2004.
- David A. Laird. Influence of layer charge on swelling of smectites, *Applied Clay Science*, Volume 34, Issues 1–4, October 2006, Pages 74-87
- Farhang Radjai and Frederic Dubois. Discrete Element Modeling of Granular Materials. *ISTE WILEY*, 2011.

# Micro-mechanical investigation of the effect of fine content on mechanical behavior of gap-graded granular materials using DEM

Ngoc-Son Nguyen<sup>1</sup>, Habib Taha<sup>1,2</sup>, Didier Marot<sup>1</sup>, Abbas Hijazi<sup>2</sup>, Khalil Abou-Saleh<sup>2</sup>

<sup>1</sup> GeM Institute, University of Nantes, 58 rue Michel Ange, BP 420, 44606, Saint-Nazaire Cedex, France

<sup>2</sup> MPLAB-Multidisciplinary Physics Laboratory, Faculty of Sciences, Lebanese University, Hadat-Baabda, Lebanon  
ngocson.nguyen@univ-nantes.fr

**Keywords:** gap-graded materials; fine content; DEM; micro-mechanical investigation

Granular materials are often used for construction of hydraulic structures such as dikes, levees, dams, etc. Under the action of the fluid flow, widely graded granular materials are susceptible to internal erosion, during which fine particles can be detached and transported with the fluid flow through the pore space between coarse particles (Sail et al., 2011). The loss of fine particles can impact the mechanical behavior of eroded materials, and then the stability of hydraulic structures. To predict this impact, it is important to deeply understand the effect of the fine content on the mechanical behavior of granular materials and consequences of the loss of fine particles on mechanical properties.

Experimental tests performed by several authors have shown that the fine content affects greatly the macroscopic behavior of granular materials (Thevanayagam et al., 2002). A loss of fine particles leads to a significant reduction in shear strength of granular mixtures (Chen et al., 2016). However, from a micro-mechanical point of view, this effect is not yet well understood. This is due to the fact that it is difficult, experimentally, to get an insight into granular samples. In this study, we use the Discrete Element Method (DEM) implemented in the open-source software YADE (Šmilauer et al., 2015) to simulate triaxial loadings on gap graded granular samples. Gap-graded granular samples with fine content  $f_c$  varying from 0% to 40% are simulated. It is shown that a low fine content  $f_c \leq 15\%$  has a negligible effect, but when  $f_c > 15\%$ , the shear strength and dilatancy of gap-graded samples increase with fine content  $f_c$ . This numerical result is qualitatively in good agreement with the experimental finding shown by Salgado et al. (2000). A micro-structural study shows that, at low fine content ( $f_c \leq 15\%$ ) fine particles are almost floating within voids between coarse particles, but at high fine content ( $f_c > 15\%$ ), they come into contact with coarse particles. Two opposing effects are observed when adding fine particles into a granular mixture: on one hand, fine particles weaken the granular skeleton by intercalating between coarse particles, but on the other hand, strengthens the granular skeleton by surrounding coarse particles. Fine particles carry almost zero-stress at low fine content, but they participate significantly in carrying the applied stress at high fine content, and their participation increases with fine content. In addition, the fine fraction plays a more important role in carrying the mean stress than in carrying the stress deviator. It is also shown that the contribution of the fine fraction to the macroscopic stress is not proportional to fine content. A fine content of 40% contributes 30.9% to the macroscopic mean stress and only 21.5% to the macroscopic stress deviator.

In a gap-graded sample, we define a loose fraction composed of fine particles which do not take part in the strong force chain. Therefore, particles in this loose fraction do not participate significantly in carrying the applied stress and they are vulnerable to internal erosion. A certain amount of fine particles in this loose fraction is then removed from the sample to mimic the loss of fine particles due to internal erosion. It is shown that a significant loss of fine particles, although they are in the loose fraction, leads to a significant reduction in shear strength of granular mixtures. A micro-mechanical study is also performed to explain this reduction in shear strength.

Moreover, the results obtained with the proposed method are compared to those obtained with other methods proposed in the literature (Scholtès et al., 2010).

### **References**

- Chen C., Zhang L.M., Chang D.S. (2016) Stress-Strain Behavior of Granular Soils Subjected to Internal Erosion. *Journal of Geotechnical and Geoenvironmental Engineering* 142:12, 06016014.
- Sail Y. , Marot D., Sibille L., Alexis A. (2011) Suffusion tests on cohesionless granular matter. *European Journal of Environmental and Civil Engineering* 15:5, 799–817.
- Salgado P., Bandini P., Karim A. (2000) Shear Strength and Stiffness of Silty Sand. *Journal of Geotechnical and Geoenvironmental Engineering ASCE* 126:5.
- Šmilauer et al. (2015) Yade Documentation 2nd ed. *The Yade Project*. DOI 10.5281/zenodo.34073 (<http://yade-dem.org/doc/>).
- Scholtès L., Hicher P.-Y., Sibille L. (2010) Multiscale approaches to describe mechanical responses induced by particle removal in granular materials. *Comptes Rendus Mécanique* 338:10-11, 627–638.
- Thevanayagam S., Shenthan T., Mohan S., Liang J. (2002) Undrained Fragility of Clean Sands, Silty Sands, and Sandy Silts. *Journal of Geotechnical and Geoenvironmental Engineering ASCE* 128:10, 849–859.

# Statistical analysis of stress in wet granular materials

Richard Wan<sup>1</sup>, Mehdi Pouragha<sup>1</sup>, Jérôme Duriez<sup>1,2</sup>

<sup>1</sup> University of Calgary, AB T2N 1N4, Calgary, Canada

<sup>2</sup> Irstea, UR RECOVER, F-13182, Aix-en-Provence, France  
wan@ucalgary.ca

**Keywords:** unsaturated conditions; effective stress; statistical analysis

The micromechanics of wet granular materials encompasses complex microstructural and capillary interconnects that can be readily described through a formal derivation of stress transport in such a three-phase medium (Duriez & Wan, 2016 ; Duriez et al., 2017). In the quest for defining an appropriate effective stress measure, the stress tensor expression that results from homogenization of such a medium provides theoretical insights necessary to extract useful information on the relationship between capillary effects and microforce interactions via several small-scale parameters whose evaluation can be challenging (Duriez et al., 2018 ; Duriez & Wan, 2018).

Using instead a statistical approach where microvariable distributions are described by probability density functions (PDFs), the current study provides simple estimates of stress components in terms of only a few tractable microvariables such as coordination number and fabric anisotropy. In particular, the latter recognizes details of contacts such as force interactions being either mechanical, capillary or distant. The developed expressions are in a good agreement with Discrete Element Method (DEM) simulation results of the triaxial loading of a wet granular assembly, notably for hydrostatic (mean) pressure. A new set of dimensionless groups is also identified to characterize the significance of mechanical and capillary physics, which facilitates a better understanding of the contribution of dominating elements to stress, while also providing the opportunity to incorporate important capillary effects in micromechanically-based constitutive formulations.

## References

- Duriez J. and Wan R. (2016) Stress in wet granular media with interfaces via homogenization and discrete element approaches, *Journal of Engineering Mechanics* 142:12
- Duriez J., Eghbalian M., Wan R. and Darve F. (2017) The micromechanical nature of stresses in triphasic granular media with interfaces, *Journal of the Mechanics and Physics of Solids* 99, 495–511
- Duriez J. and Wan R. (2018) A micromechanical  $\mu$ UNSAT effective stress expression for stress-strain behaviour of wet granular materials, *Geomechanics for Energy and the Environment*, doi:10.1016/j.gete.2017.12.003
- Duriez J., Wan R., Pouragha M. and Darve F. (2018) Revisiting the existence of an effective stress for wet granular soils with micromechanics, *International Journal for Numerical and Analytical Methods in Geomechanics*, doi:10.1002/nag.2774



## 3D simulations of the granulation of wet granular materials

Thanh-Trung Vo<sup>1,2</sup>, Patrick Mutabaruka<sup>3</sup>, Saeid Nezamabadi<sup>1</sup>, Jean-Yves Delenne<sup>4</sup>, Farhang Rad-jai<sup>1,3</sup>

<sup>1</sup> Laboratoire de Mécanique et Génie Civil, Université de Montpellier, CNRS, Montpellier, France.

<sup>2</sup> Bridge and Road Department, Danang Architecture University, Danang, Vietnam.

<sup>3</sup> <MSE>, UMI 3466 CNRS-MIT, MIT, 77 Massachusetts Av, Cambridge 02139, USA.

<sup>4</sup> IATE, UMR1208 INRA-CIRAD-Université de Montpellier-SupAgro, Montpellier, France.

thanh-trung.vo@umontpellier.fr

**Keywords:** size ratio; capillary bridge; molecular dynamics; rotating drum; iron ore

Agglomeration of fine particles is used in many industrial processes such as powder metallurgy (Nosrati et al. 2012), iron-making industry (Aguado et al. 2013), food and pharmaceutical industries (Chien et al. 2003). Fine granular materials are prepared and mixed in required proportions, compacted into a granule or tablet and finally sintered to acquire sufficient mechanical strength and toughness needed for subsequent operations. We present a numerical model for the agglomeration of wet particles. The particles interact through capillary liquid bridges, which are modeled by accounting for the cohesive and viscous forces expressed analytically as a function of different parameters such as the distance between primary particles, liquid volume and viscosity, surface tension and particle sizes (Richefeu et al. 2007). The model also assumes that the liquid is transported by the primary particles modeled as agglomerates of finer particles. We find that this model is able to simulate the agglomeration of particles in a rotating drum in which a given amount of liquid is homogeneously distributed. Our simulation show that the granule size increases exponentially with the number of drum rotations and in proportion to the amount of liquid. We investigate the effects of process parameters such as particle size distribution, friction coefficient between the primary particles and liquid viscosity. We also consider the effect of cohesion on different flow regimes as a function of Froude number.

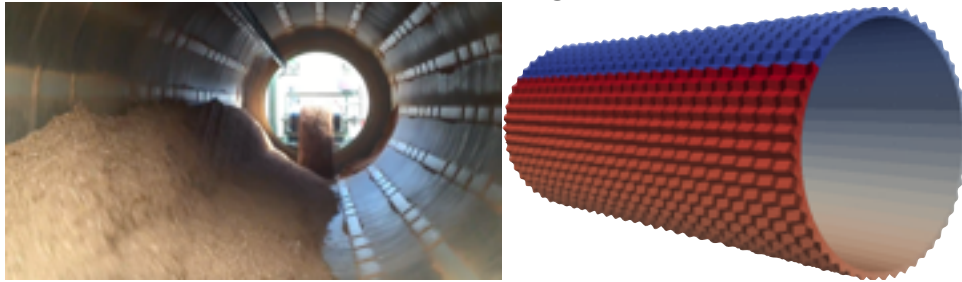

**Figure 1** Industrial and numerical granulation drum.

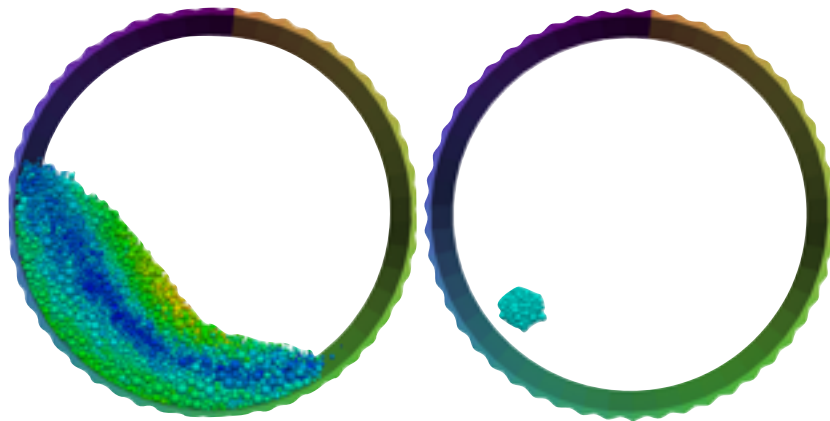

**Figure 2** Snapshots represent the agglomeration process of solid particles in a horizontal rotating drum, granular flow on the left and granule is formed and it grows with the number of rotations of drum on the right.

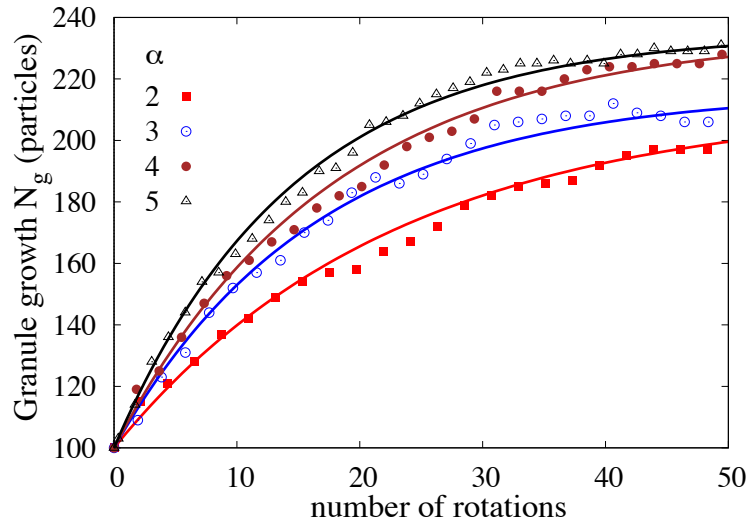

**Figure 3** The evolution of the size of the granule as a function of the number of rotations for different values of the size ratio.

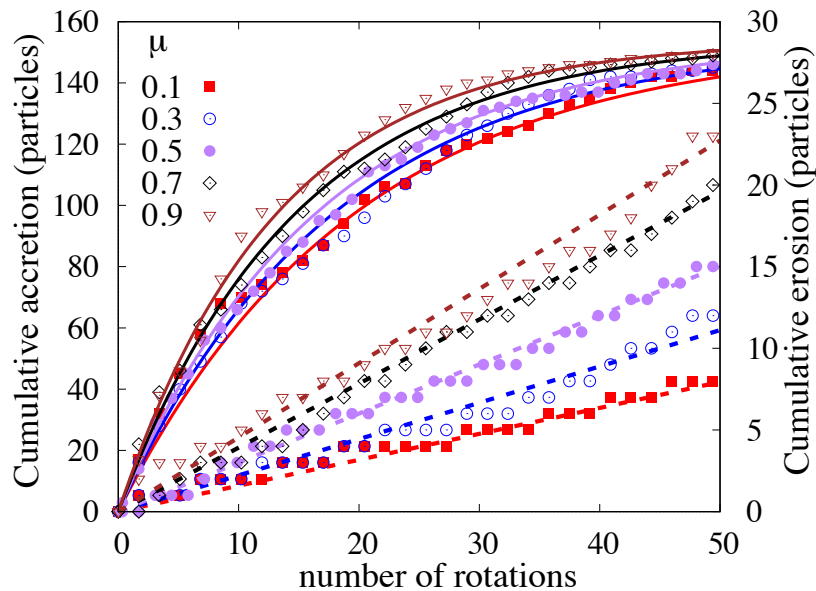

**Figure 4** The exponential increase function of accretion (continuous lines) and the nearly linear function of erosion (dash lines) for different values of friction coefficient.

## References

- A. Nosrati, J. Addai-Mensah, D.J. Robinson. (2012), *Drum agglomeration behavior of nickel laterite ore: Effect of process variables*, Hydrometallurgy 125–126, 90
- R. Aguado, S. Roudier, L. Delgado. (2013) *Best available techniques (BAT) reference document for iron and steel production*, Joint Research Centre of the European Commission.
- S.H. Chien, G. Carmona, L.I. Prochnow, E.R. Austin. (2003), *Cadmium availability from granulated and bulk-blended phosphate-potassium fertilizers*, J Environ Qual 32 (5), 1911
- V. Richefeu, F. Radjai and M.S.E. Yousoufi. (2007), *Stress transmission in wet granular materials*, Eur. Phys. J. E 21, 359

# Elasticity and decomposition of strain in granular materials

Mehdi Pouragha<sup>1</sup>, Richard Wan<sup>1</sup>

<sup>1</sup> University of Calgary, AB T2N 1N4, Calgary, Canada  
mpouragh@ucalgary.ca

**Keywords:** Elasticity; Granular materials; Micromechanics; Contact fabric

The origin of global deformations in granular media stems from various concurrent mechanisms at the microscopic scale. Recent micromechanical studies have pointed out inadequacies of traditional elasto-plastic theories with elastic nucleus to describe such materials. In addition, the fundamentals of additive decomposition of global strain into mechanism-specific contributions have also been questioned from a multiscale point of view due to appearance of emergent nonlinearities in the global response. The current study addresses the decomposability of strain and the existence of an elastic zone by systematically scrutinizing the energy aspects of granular deformation under quasi-static loading regime. The results show that the assumption of an exclusively elastic nucleus can potentially introduce non-negligible errors, even at strain ranges below  $10^{-4}$ . By relaxing commonly used assumptions which are often restrictive, a new constitutive model for elastic deformations in granular materials is developed to capture material response as a function of microstructure of the granular assembly (Pouragha & Wan, 2018). After verification through comparisons with discrete elements simulations, the model has been used to investigate the decomposability of strain. The results demonstrate that the elastic strain component can only be extracted through numerical simulations where the dissipative mechanisms are “artificially” prohibited, which relegates the strain decomposition to an abstract concept.

## References

Pouragha M. and Wan R. (2018) On elastic deformations and decomposition of strain in granular media, *International Journal of Solids and Structures* 138, 97–108

# Microscopic features of liquefaction

Colin Thornton<sup>1</sup>, Eduardo Martin<sup>2</sup>, Stefano Utili<sup>3</sup>

<sup>1</sup> University of Birmingham, B15 2TT, Birmingham, UK

<sup>2</sup> Universidad Nacional de San Juan, San Juan, Argentina

<sup>3</sup>Newcastle University, NE1 7RU, Newcastle, UK

c.thornton@bham.ac.uk

**Keywords:** DEM; cyclic straining; liquefaction; isostaticity

Discrete element simulations of undrained axisymmetric compression have been applied to gravel-sand mixtures using the YADE code. Assemblies were subjected to cyclic straining in order to examine their liquefaction potential. Here, we focus on one assembly of 10000 particles with a relative density of 40% (porosity = 0.416), 25% sand content and initial confining pressure of 250 kPa. Throughout cyclic loading the mechanical coordination number,  $Z_m$ , the redundancy index,  $I_R$ , and the cluster evolution were monitored.

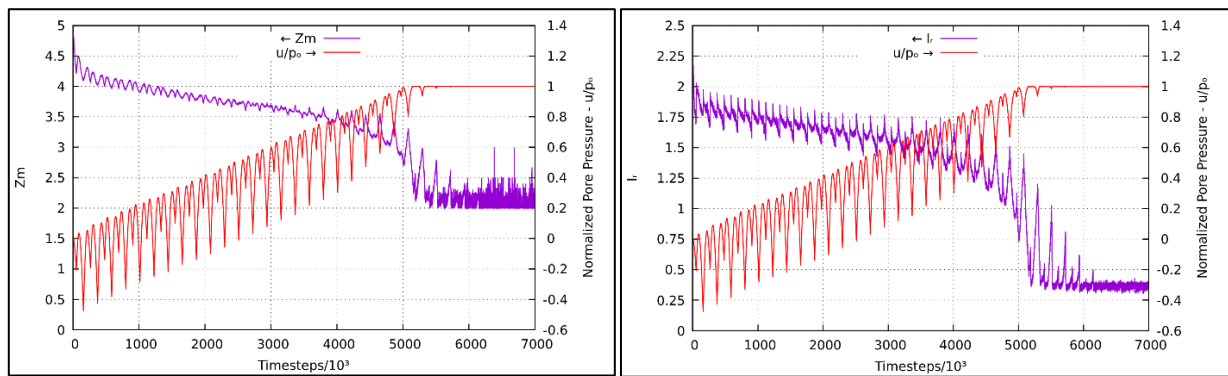

**Figure 1** Evolution of the normalized pore pressure, the mechanical coordination number and the redundancy index

Figure 1 shows the evolution of the normalized pore pressure, the mechanical coordination number and the redundancy index. It can be seen that the normalized pore pressure first reaches unity after 5 million timesteps and that, at this point, the mechanical coordination number  $Z_m = 3$  and the redundancy index  $I_R = 1$ . Hence, at this point the system is isostatic.

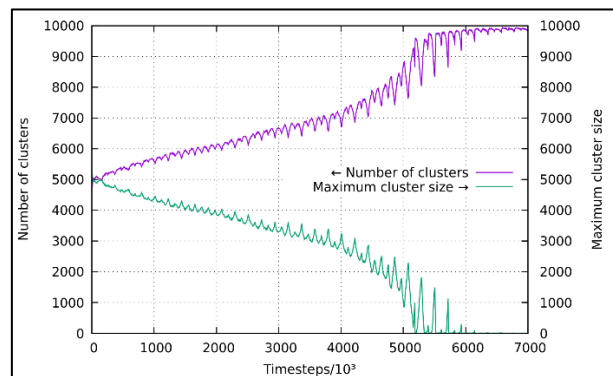

**Figure 2** Evolution of maximum cluster size and number of clusters

Figure 2 shows the evolution of the size of the maximum cluster and the number of clusters. It can be seen that with continued cyclic loading the maximum cluster size decreases and the number of clusters increases.

It is concluded that as the pore pressure increases (the mean effective stress decreases) the magnitude of the normal contact forces reduces. With continued decrease in the mean effective stress an increasing number of contact normal forces reduce to zero and contacts are lost. Interestingly, the figure suggests that the loss of contacts is uniformly distributed throughout the assembly and that there is no breakup of the large cluster into smaller clusters. It appears that, during degradation of the initial large cluster, only singlets are created increasing the number of ‘rattlers’. Figure 3 illustrates the largest remaining cluster of 1229 particles when  $u/p_0$  first becomes unity.

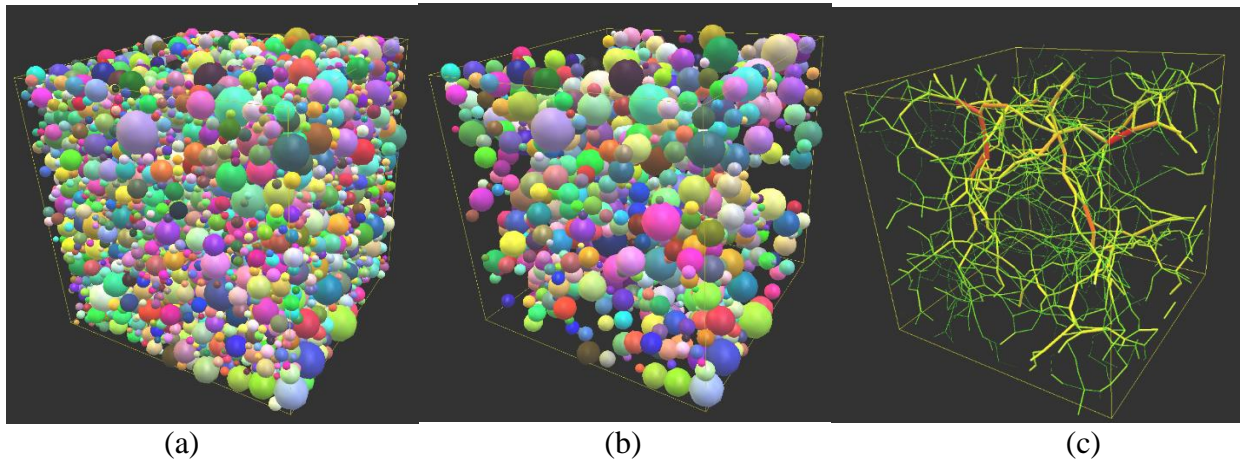

**Figure 3** Particle assembly details after 5 million timesteps (a) complete arrangement of particles (b) the largest remaining cluster and (c) the force chain network within the cluster

## Evolution of strength and structure of crushable grain assemblies

David Cantor <sup>1,2</sup>, Emilien Azéma<sup>1</sup>, Philippe Sornay <sup>2</sup>, Farhang Radjaï<sup>1</sup>  
<sup>1</sup> LMGC, Univ. Montpellier, CNRS, 34095, Montpellier, France  
<sup>2</sup> CEA, DEN, DEC, SFER, LCU, F-13108, Saint Paul lez Durance, France  
 david.cantor@umontpellier.fr

**Keywords:** Compaction; grain fragmentation; grain shape; grain size distribution

By means of a discrete element approach to grain fragmentation in 3D, known as Bonded Cell Method (BCM) (Nguyen et al. 2015; Cantor et al. 2017), we studied the oedometric compression of assemblies of grains. This approach allows grains and fragments to evolve in diverse sizes and polyhedral shapes (see Fig. 1). Different assemblies, with varying grain strength, were built and tested. We analyzed the load-density relations, the grain size distribution and the grain shape evolution during the compaction. In particular, we find that the load-density evolution follows a logarithmic relation due to the grain rearrangement and fragmentation. Remarkably, the early stages of the compression, at relative low stress levels, seems to strongly determine the later evolution of the granular system. The grain size distribution is found to follow a well-defined power law with no characteristic size, and the grain shape, regardless of the grain strength, tends always to a self-similar aspect ratio.

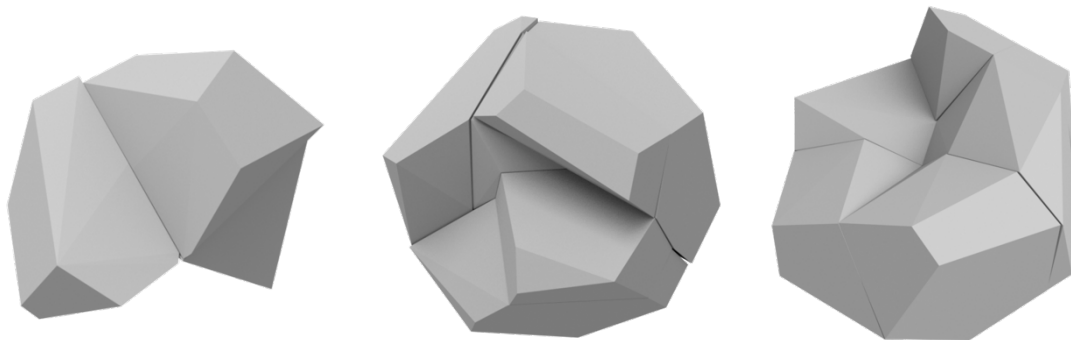

**Figure 1** Examples of fragments shapes produced during the compaction.

### References

- Cantor, D. et al., 2017. Three-dimensional bonded-cell model for grain fragmentation. *Computational Particle Mechanics*, 4(4), pp.441–450. Available at: <http://link.springer.com/10.1007/s40571-016-0129-0>.
- Nguyen, D.-H. et al., 2015. Bonded-cell model for particle fracture. *Physical Review E*, 91(2), p.22203. Available at: <http://link.aps.org/doi/10.1103/PhysRevE.91.022203>.

### Acknowledgements

This research was financially supported by the French Alternative Energies and Atomic Energy Commission. D. Cantor thanks J. Laithier for her advice and stimulating discussions.

## Dynamic fragmentation of grains under impact

Luisa Fernanda Orozco<sup>1,4</sup>, Jean-Yves Delenne<sup>3</sup>, Philippe Sornay<sup>4</sup>, Farhang Radjai<sup>1,2</sup>

<sup>1</sup>LMGC, Univ. Montpellier, CNRS, Montpellier, France

<sup>2</sup>UMI 3466 CNRS-MIT, CEE, Massachusetts Institute of Technology (MIT), 77

<sup>3</sup>INRA, UMR IATE Montpellier, France

<sup>4</sup>CEA, DEN, DEC, SFER, LCU, 13108 Saint Paul les Durance, France

luisa.orozco@umontpellier.fr

**Keywords:** Dynamic fragmentation; Breakage; Granular materials; Contact Dynamics Method.

Many industrial granular processes involve desired or undesired fragmentation of grains. However, despite experimental measurements and numerical modelling approaches, the mechanisms of single grain fragmentation under dynamic conditions and its effects on the behaviour of granular materials are still poorly understood. In this work, we investigate the fracture and fragmentation of a single grain due to impact, using three dimensional DEM simulations by means of the contact dynamics method. The grains are assumed to be perfectly rigid but modelled as an assembly of glued polyhedral Voronoï cells. The cells are connected/glued to each other by means of a cohesive law that is defined by two resistance parameters: in the normal direction at the contact level the tensile strength ( $C_n$ ) restrains the separation between cells and, in the tangential direction a shear resistance ( $C_t$ ) is imposed. When the contact forces between cells divided by the contact surface reach  $C_n$  or  $C_t$ , a crack may start to develop, and the cohesive behaviour will be lost when the energy consumed by this process reach the free surface energy of the material  $\gamma$ .

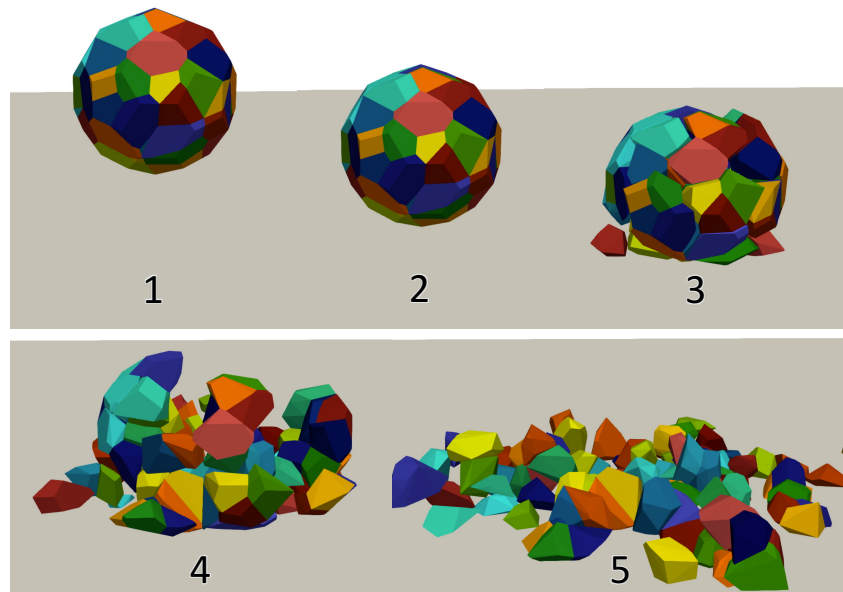

**Figure 1** Sequence of a single grain fragmentation impacting a rigid plane. Each of the 100 cells that conform the grain is presented with a unique colour.

In order to understand how the model parameters influence the energy absorbed in the process, a set of tests have been performed varying the impact velocity, number of cells,  $\gamma$ , among others. Both, the absorbed energy and the number of generated fragments regarding the impact velocity, presents an ‘S’ shaped curve, wherein the lower velocities produce almost no fragmentation; as it is increased a bigger amount of energy is absorbed reaching a saturation at high values of velocity. With regard to the fragmentation efficiency, defined as the ratio between the absorbed energy and the kinetic energy at the impact, the results evidence an optimal value. It means that is possible to find a force that will reduce the amount of energy lost in the process.

### ***Acknowledgements***

The authors would like to acknowledge the financial support from CEA to this investigation.



# Experimental and numerical investigation of highly deformable particle systems

Thi Lo Vu, Jonathan Barés, Saeid Nezamabadi, Serge Mora  
LMGC, Univ.Montpellier, CNRS, Montpellier, France  
thi-lo.vu@umontpellier.fr

**Keywords:** Hertz's contact law; Large deformations; Digital Image; Finite element simulations

Granular materials composed of soft particles which can undergo large deformations are ubiquitous in pharmaceutical, food, cosmetic industries as well as in biological systems. The large deformations of the particles strongly affect the mechanical behavior of the system compared to hard particle granular materials more often considered in research on granular materials. In this work, we investigated and analyzed the rheological behavior of a model system of deformable particles subjected to uniaxial compression by means of experimental and numerical approaches. The experimental studies are carried out using an original apparatus capable of compressing the soft grains while imaging them. A Digital Image Correlation algorithm (Mora, 2017) is developed to measure the displacement field inside the particle. These experimental results are compared with finite element simulations (Figure 1) using the software LMGc90 (LMGC).

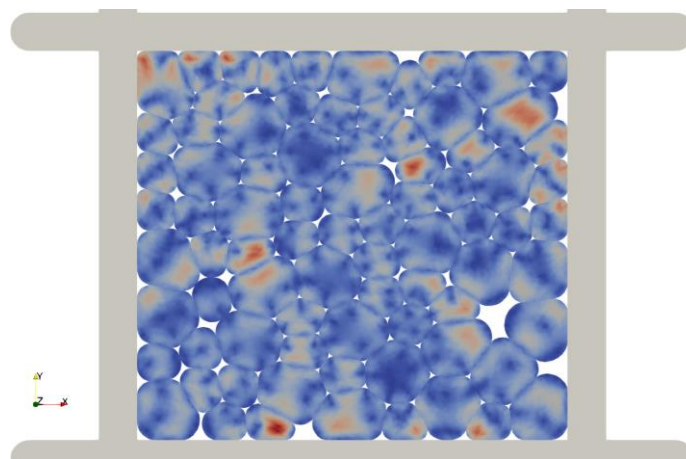

**Figure 1** Uniaxial compression of a system of deformable particles

## References

- LMGC. Lmgc90. [https://git-xen.lmgc.univ-montp2.fr/lmgc90/lmgc90\\_user/wikis/home](https://git-xen.lmgc.univ-montp2.fr/lmgc90/lmgc90_user/wikis/home).  
S. Mora (2017) Highly deformed grain: from the Hertz contact limitation to a new strain field description in 2D, *EPJ Web of Conferences* 140, 05011.

# Modeling deformable granular materials using Material Point Method

Saeid Nezamabadi<sup>1</sup>, Thanh Hai Nguyen<sup>2</sup>, Jean-Yves Delenne<sup>3</sup> and Farhang Radjai<sup>1,4</sup>

<sup>1</sup> LMGC, Université de Montpellier, CNRS, Montpellier, France

<sup>2</sup> University of Danang - University of Science and Technology, Danang, Vietnam

<sup>3</sup> IATE, CIRAD, INRA, Montpellier SupAgro, Université de Montpellier, Montpellier, France

<sup>4</sup> <MSE><sup>2</sup>, UMI 3466 CNRS-MIT, CEE, Massachusetts Institute of Technology, Cambridge, USA  
saeid.nezamabadi@umontpellier.fr

**Keywords:** Material point method; Contact dynamics; Granular materials

This work concerns modeling of deformable granular materials in which the grains can change their shape by deforming elastically or inelastically. These materials can hence reach high packing fraction and flow by particle shape change as well as particle rearrangements. Most cosmetics, food products, pastes, many powders, emulsions and colloidal suspensions are such materials. Here, the rheological behavior of deformable granular systems are studied by means of two numerical approaches: (i) an implicit formulation of the Material Point Method (MPM) combined with the Contact Dynamics (CD) method to deal with contact interactions (Nezamabadi et al. 2015), and (ii) Bonded Particle Model (BPM), in which each deformable particle is modeled as an aggregate of rigid primary particles using the CD method (Nezamabadi et al. 2017). These two approaches allow us to investigate the compaction and shear behavior of an assembly of elastic or plastic grains by analyzing the effects of grain shape change on the stress-strain relationship and volume change behavior as well as the evolution of the microstructure.

## References

- Nezamabadi S., Radjai F., Averseng J. and Delenne J.-Y. (2015) Implicit frictional- contact model for soft particle systems, *Journal of the Mechanics and Physics of Solids* 83, 72–87.
- Nezamabadi S., Nguyen T.H., Delenne J.-Y. and Radjai F., Modeling soft granular materials, *Granular Matter* 19, 8.

## Numerical and experimental modeling of cemented soils

Pierre Philippe<sup>1</sup>, Florian Brunier-Coulin<sup>1</sup>, Zeyd Benseghier<sup>1</sup>, Pablo Cuéllar<sup>2</sup>,  
Jean-Yves Delenne<sup>3</sup>, Stéphane Bonelli<sup>1</sup>

<sup>1</sup> IRSTEA, 13182, Aix-en-Provence, France

<sup>2</sup> BAM, 12205, Berlin, Germany

<sup>3</sup> INRA, 34060, Montpellier, France  
pierre.philippe@irstea.fr

**Keywords:** Discrete Element Method; Lattice Boltzmann Method; Soil erosion; Cohesion

The present contribution reports a methodology to investigate, both experimentally and numerically, the resistance to fluid flow erosion of a so-called cemented soil, considered here as cohesive granular material whose particles are bonded by solid bridges. To this end, artificial granular systems are used, constituted of spherical grains interconnected by solid bonds with a yield strength  $\tau_Y$  that can be varied systematically. It is proposed to introduce a cohesion number  $Co$  comparing this bond yield strength to the buoyant weight of a particle, in order to implement a parametric analysis against this dimensionless group.

In more details, the experimental system is made of borosilicate glass beads, bridged in pairs by solid bonds of resin, while a mixture of mineral oils is used as surrounding liquid phase so as to almost match optically all phases (solid spheres, solid bonds and liquid). Then, as illustrated in Figure 1, a combination with Planar Laser Induced Fluorescence allows probing non-intrusively the system and therefore observing locally soil erosion generated by an impinging jet (Brunier-Coulin et al., 2017). Additionally, both micro-scale and sample-scale set-ups have been developed to determine the tensile strength of these artificial cemented materials.

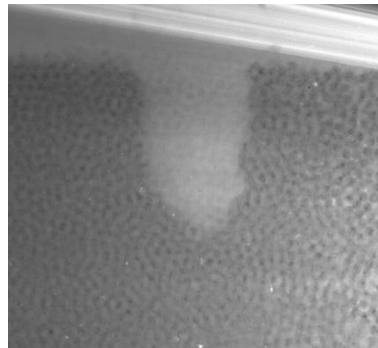

**Figure 1** Typical image obtained by optical techniques for impinging jet erosion of an artificial cemented soil made of glass beads, resin bonds and mineral oil mixture as surrounding liquid.

From a numerical point of view, a 2D modeling has been implemented, based on the coupling of Discrete Element Method (DEM) and Lattice Boltzmann Method (LBM) (Cuéllar et al., 2015). As demonstrated by its increasingly widespread use, this technique is one of the best enabling to specify consistently the hydrodynamic interaction between a discrete solid phase and a surrounding fluid flow. The DEM part was further enriched by the introduction of a contact rheology where the yield condition of the solid bonds is prescribed by a paraboloid yield surface comprising traction, shear and rolling efforts (Delenne et al., 2004). A bond damage model is also included, thus introducing an internal time scale for contact bond failure (Silvani et al., 2009). A simple Couette flow configuration is investigated here (see Figure 2), much less complicated than jet's impingement, in order to relate quantitatively the erodibility parameters, which quantify soil's resistance to erosion at sample-scale, to the input microscopic parameters of the solid bonds.

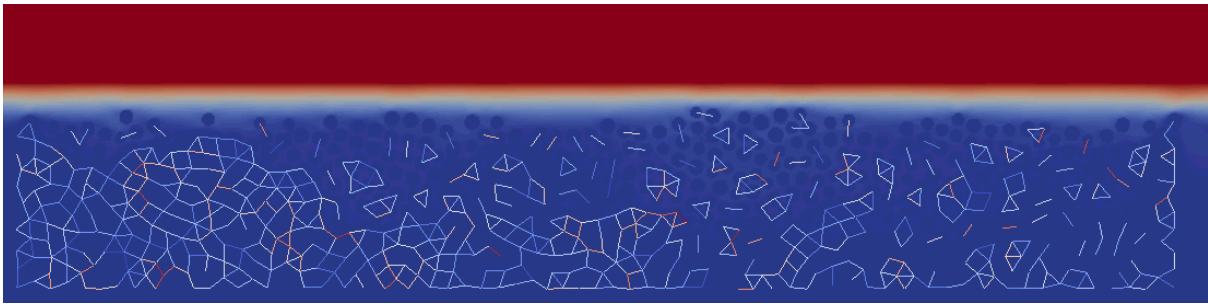

**Figure 2** DEM-LBM simulation of a cemented soil being eroded by a Couette fluid flow.

### **References**

- Brunier-Coulin F., Cuéllar P. and Philippe P. (2017) Erosion onset of a cohesion-less granular medium by an immersed impinging round jet, *Physical Review Fluids* 2, 034302.
- Cuéllar P., Philippe P., Bonelli S., Benahmed N., Brunier-Coulin F., Ngoma, J. Delenne, J.-Y. and Radjai, F. (2015) Micromechanical analysis of the surface erosion of a cohesive soil by means of a coupled LBM-DEM model, *Proc. 4th Int. Conf. on Particle-based Methods, PARTICLES*.
- Delenne J.-Y., El Youssoufi M.S., Cherblanc F. and Bénéat J.-C. (2004) Mechanical behaviour and failure of cohesive granular materials, *Int. J. Numer. Anal. Meth. Geomech.* 28: 1577–1594.
- Silvani C., Bonelli S. and Désoyer T. (2009) A discrete modelling of the time-dependent behavior of rockfill, *Int. J. Numer. Anal. Meth. Geomech.* 33: 665–685.

### **Acknowledgements**

F. Brunier-Coulin and Z. Benseghier's PhD thesis benefited from studentship fundings of Provence-Alpes-Côte-d'Azur (PACA) region. The authors also acknowledge another financial help from PACA region through the project ESCAPE (APEX program).

## Use of DEM-LBM modeling to prove the relevance of free jet model for soil erosion by impinging jet

Zeyd Benseghier<sup>1</sup>, Pablo Cuéllar<sup>2</sup>, Li-Hua Luu<sup>1</sup>, Jean-Yves Delenne<sup>3</sup>, Stéphane Bonelli<sup>1</sup> and Pierre Philippe<sup>1</sup>

<sup>1</sup> IRSTEA, French Research Institute of Science and Technology for Environment and Agriculture, 3275 route de Cézanne, 13100 Aix-en-Provence, France.

<sup>2</sup> Federal Institute for Materials Research and Testing (BAM), Division 7.2 for Buildings and Structures, Unter den Eichen 78, 12205 Berlin, Germany.

<sup>3</sup> INRA/CIRAD/Montpellier Supagro/UM2, 2 place Pierre Viala, 34060 Montpellier, France.

**Keywords:** Free jet; Impingement jet; Lattice Boltzmann Method; Discrete Element Method; Soil erosion.

The surface erosion of a cohesive soil by an impinging jet is the principle behind the Jet Erosion Test (JET), a common experimental test which was first introduced by Hanson & Cook (2004) to characterize the resistance against erosion of cohesive soils. In this work, the JET is investigated numerically at the microscale by a coupled fluid-particle modeling (Cuéllar et al, 2015). The methods chosen for the present simulation are the Lattice Boltzmann Method (LBM) for the fluid phase and the Discrete Element Method (DEM) proposed by Cundall & Strack (1979) for describing the motion of the solid particles. In addition, cohesion between particles is insured by a visco-elastic cohesive model with paraboloidal yield surface proposed by Delenne et al (2004). Here, we focus specifically on the determination of the flow characteristics of a vertical impinging jet on a fixed horizontal granular bed surface in order to assess the suitability and relevance of commonly used empirical estimations based on the free jet self-similar model (Figure 1). Then the erosion thresholds for both cohesive and cohesionless particles can be accurately determined and compared to previous experimental data (Figure 2).

In the present contribution, we firstly introduce a 2D model of a laminar free jet which is validated against well-known theoretical solutions. Then, we present a parametric study of a frontal jet impingement, at first on a solid regular surface and afterwards on a fixed granular layer, while taking into account variations of particle sizes, of distance from the jet origin and of jet's Reynolds number. This analysis helps us understand the hydrodynamics phenomenology and quantify the flow characteristics at the bed surface, including maximum velocity and wall shear stress which can be regarded as the main cause of particles detachment under hydrodynamic forces. We found that overall results obtained agree with the free jet self-similar model by introducing some simple empirical coefficients.

Finally, we perform series of jet erosion test on both cohesive and non-cohesive particles with varying particle size and inter-particle cohesion. The corresponding erosion threshold values, at which the motion of particles start to initiate, are qualitatively in good agreement compared to both Shields diagram and previous experimental results (Badr et al, 2014; Brunier-Coulin et al, 2017) for cohesionless particles and to the modified Shields parameter for cohesive granular materials proposed by Brunier-Coulin et al (2016).

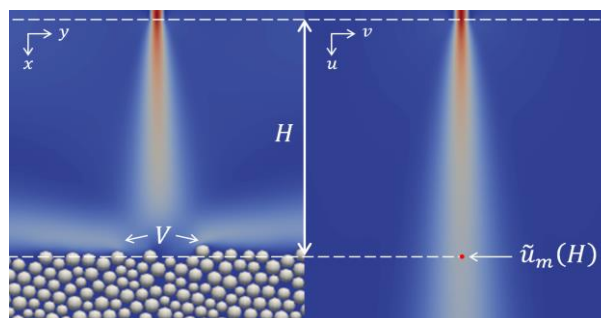

**Figure 1** Simulations of: (a) a jet impinging a granular sample and (b) the corresponding free jet.

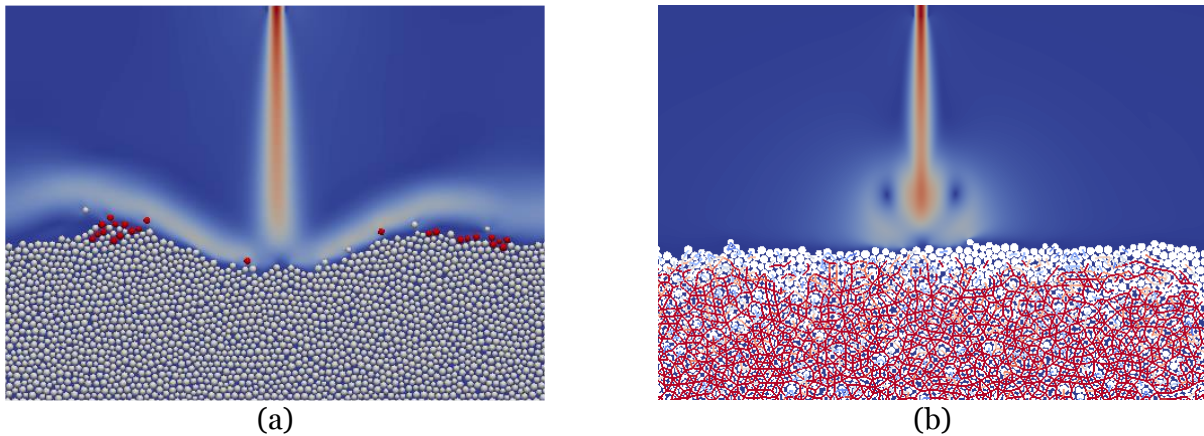

**Figure 2** Jet Erosion Test simulation for: (a) non-cohesive and (b) cohesive particles.

### References

- Badr, S., Gauthier, G., and Gondret, P. (2014) Erosion threshold of a liquid immersed granular bed by an impinging plane liquid jet, *Physics of Fluids*, 26(2), 023302.
- Brunier-Coulin, F. (2016). Etude des mécanismes élémentaires de l'érosion d'un sol cohésif, Ph.D. thesis, Aix-Marseille university.
- Brunier-Coulin, F., Cuéllar, P., and Philippe, P. (2017) Erosion onset of a cohesionless granular medium by an immersed impinging round jet. *Physical Review Fluids*, 2(3), 034302
- Cuéllar, P., Philippe, P., Bonelli, S., Benahmed, N., Brunier-Coulin, F., Ngoma, J., Delenne, J.-Y., and Radjai, F. (2015) Micromechanical analysis of the surface erosion of a cohesive soil by means of a coupled LBM-DEM model, *Proc. 4<sup>th</sup> Int. Conf. on Particle-based Methods, PARTICLES 2015*.
- Cundall P.A. and Strack O. D. L. (1979) A discrete numerical model for granular assemblies, *Géotechnique* 29:1, 47–65.
- Delenne, J.-Y., El Youssoufi, M.S., Cherblanc, F. and Bénéat, J.-C. (2004) Mechanical behavior and failure of cohesive granular materials, *Int. J. Numer. Anal. Meth. Geomech.*, Vol. 28, pp. 1577–1594.
- Hanson, G. and Cook, K. (2004) Apparatus, test procedures, and analytical methods to measure soil erodibility in situ, *Applied engineering in agriculture*, 20(4), 455.

### Acknowledgements

Z. Benseghier is supported through a studentship funding provided by PACA region. A fruitful partnership with the engineering company SAFEGE is also gratefully acknowledged.

## Multiscale numerical investigation of cover-collapse sinkhole in cohesive soils

Li-Hua Luu<sup>1,2</sup>, Pierre Philippe<sup>2</sup>, Gildas Noury<sup>1</sup>

<sup>1</sup> BRGM, DRP, 3 Av. Claude Guillemin, 45060 Orléans, France

<sup>2</sup> IRSTEA, UR RECOVER, 3275 route de Cézanne, 13182 Aix-en-Provence, France  
li-hua.luu@irstea.fr

**Keywords:** sinkhole; cohesive soil; backward erosion; coupled LBM-DEM method

Cover-collapse sinkholes severely damage agricultural sites, roads and buildings, leading to substantial engineering and environmental issues. This study aims to better understand how excessive groundwater seeping can trigger hydro-mechanical instabilities in a cohesive soil overlying a finite size cavity, as for instance encountered within soluble bedrock in karstic context. To tackle this problem from a physical perspective, we propose to investigate the elementary mechanisms at the scale of the interaction between a fluid phase and an assembly of solid particles by using a numerical method which combines the Lattice Boltzmann Method and the Discrete Elements Method. This coupled LBM-DEM method has recently proved its relevance in dealing with complex geomechanical problems that involve water-flow erosion (Tran *et al.*, 2017; Cuéllar *et al.*, 2017). Here, a previously developed two-dimensional coupled DEM-LBM code that includes a cohesion model is implemented to reproduce the backward erosion of a cohesive soil above an underground cavity (Luu *et al.*, 2017). In particular, our investigation focuses on the clogged conduit washout (Fig. 1), considered as a frequent scenario in real in-situ situations. To capture the physical origin of this regressive process, our analyses notably examine the evolution of both the hydrodynamic parameters (velocity field, pore pressure, hydrodynamic force) and the granular cohesion parameters at different scales (interparticle force, force chain).

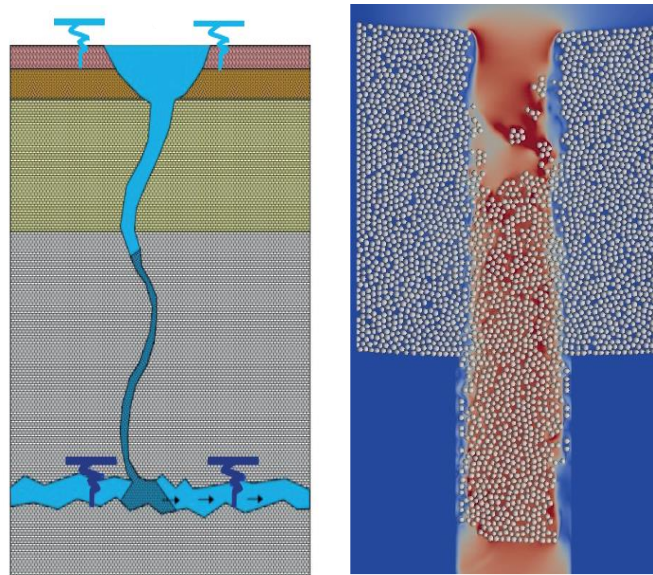

**Figure 1** Plausible scenario in field situation of soil collapse within a flooded underground conduit proposed by BRGM (left). LBM-DEM numerical simulation of a backward erosion (right).

### **References**

- Cuéllar, P., Benseghier, Z., Luu, L.H., Bonelli, S., Delenne, J.-Y., Radjai, F., & Philippe, P. (2017) Numerical insight into the micromechanics of jet erosion of a cohesive granular material. *EPJ Web of Conferences* (Vol. 140, p. 15017). *EDP Sciences*.
- Luu, L. H., Philippe, P., Noury, G., Perrin, J., & Brivois, O. (2017) Erosion of cohesive soil layers above underground conduits. *EPJ Web of Conferences* (Vol. 140, p. 09038). *EDP Sciences*.
- Tran, D. K., Prime, N., Froiio, F., Callari, C., & Vincens, E. (2017) Numerical modelling of backward front propagation in piping erosion by DEM-LBM coupling, *European Journal of Environmental and Civil Engineering* 21.7-8: 960-987.

### **Acknowledgements**

This work is funded by the PERCIVAL French regional project (Région Centre, 2017 call). We thank P. Cuéllar, Z. Benseghier, O. Brivois and J. Perrin for fruitful discussions.



## Micromechanical study of multiphase flow based on the lattice Boltzmann method

Eduard Puig Montellà<sup>1,2</sup>, Bruno Chareyre<sup>1</sup>, Simon Salager<sup>1</sup>, Antonio Gens<sup>2</sup>

<sup>1</sup> University Grenoble Alpes (UGA), F-38000 Grenoble, France

<sup>2</sup> Technical University of Catalonia (UPC), 08034, Barcelona, Spain  
 eduard.puigmontella@3sr-grenoble.fr

**Keywords:** Multiphase flow; lattice Boltzmann; porous media;

Evolution of liquid structures in unsaturated granular media is studied at the pore scale in order to better understand the solid-liquid interactions. Flow through porous media is simulated using the multicomponent Shan-Chen lattice Boltzmann method (LBM) (Shan & Chen, 1993). The hydrodynamic behavior of the model is validated by simulating the capillary rise in a tube.

Fluid displacement is simulated for capillary tubes of different cross-section (see Figure 1). Capillary pressure ( $P_c$ ) and degree of saturation ( $S_w$ ) curves are obtained and compared with the analytical results provided by the solution given by Mason & Morrow (1984) (MS-P solution). Good agreement with MS-P solution is also found in terms of meniscus curvature.

Liquid bridges and clusters are simulated (see Figure 2) under drying condition. Simple sphere-pack systems of 2-spheres and 3-spheres connected by liquid structure are presented. Capillary forces, volume and profile are compared with the analytical solution and approximations inspired by the MS-P method. A simplified model based on pore-network subsets of a granular assembly is being develop to simulate unsaturated granular materials. A proof of concept is offered in 2D. This model tracks the evolution of the interface and the primary drainage curve when the liquid of the cluster is dried out. Drainage is modeled in a network represented by pore throats and pore bodies. The algorithm for the drainage simulation proceeds with an increment of curvature as the capillary pressure is increased finding a new equilibrium configuration. Analytical results presented with the 2D model coincide with the LB simulations (see Figure 3).

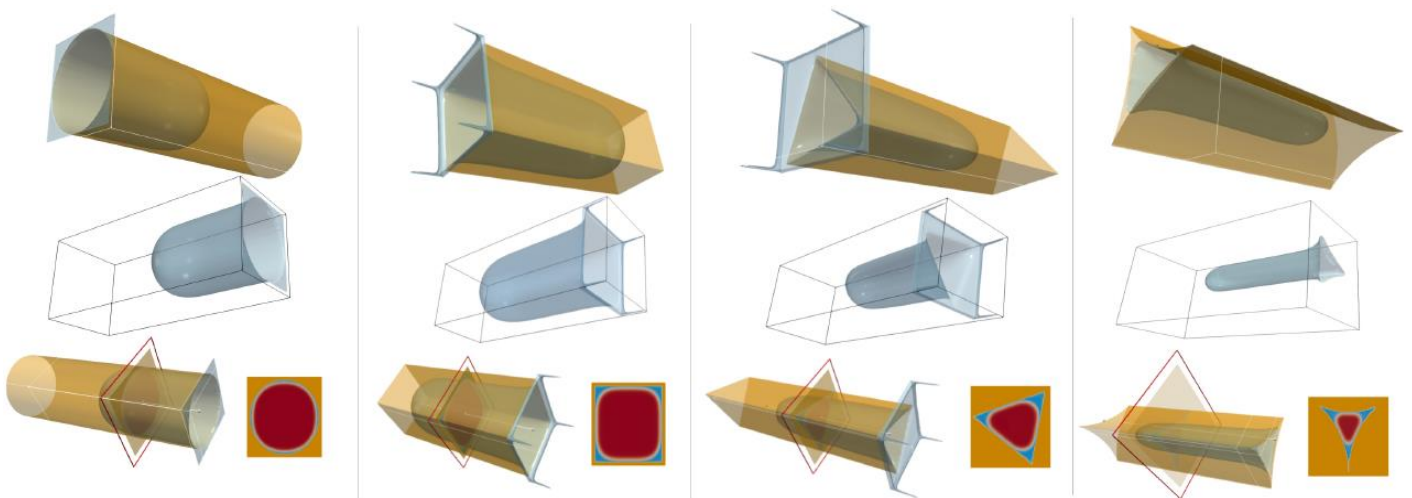

**Figure 1** Fluid displacement through circular and polygonal tubes.

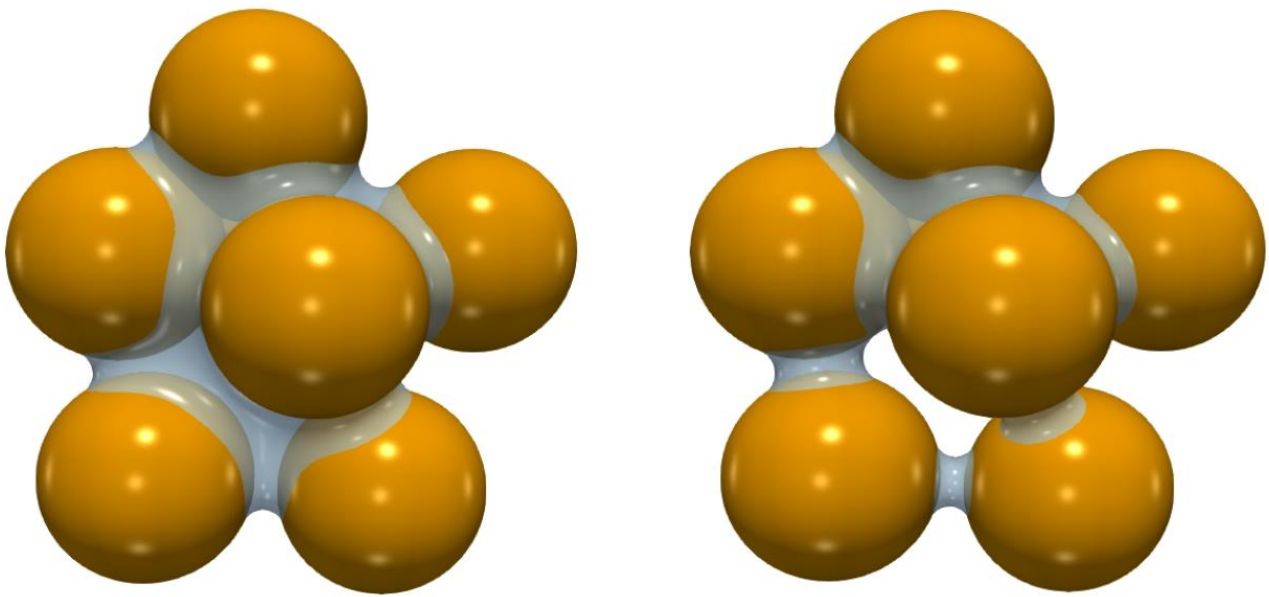

**Figure 2** Evolution of a fluid cluster simulated using the LBM. Liquid cluster on the initial state on the left. Isolated liquid bridges after the drying process on the right.

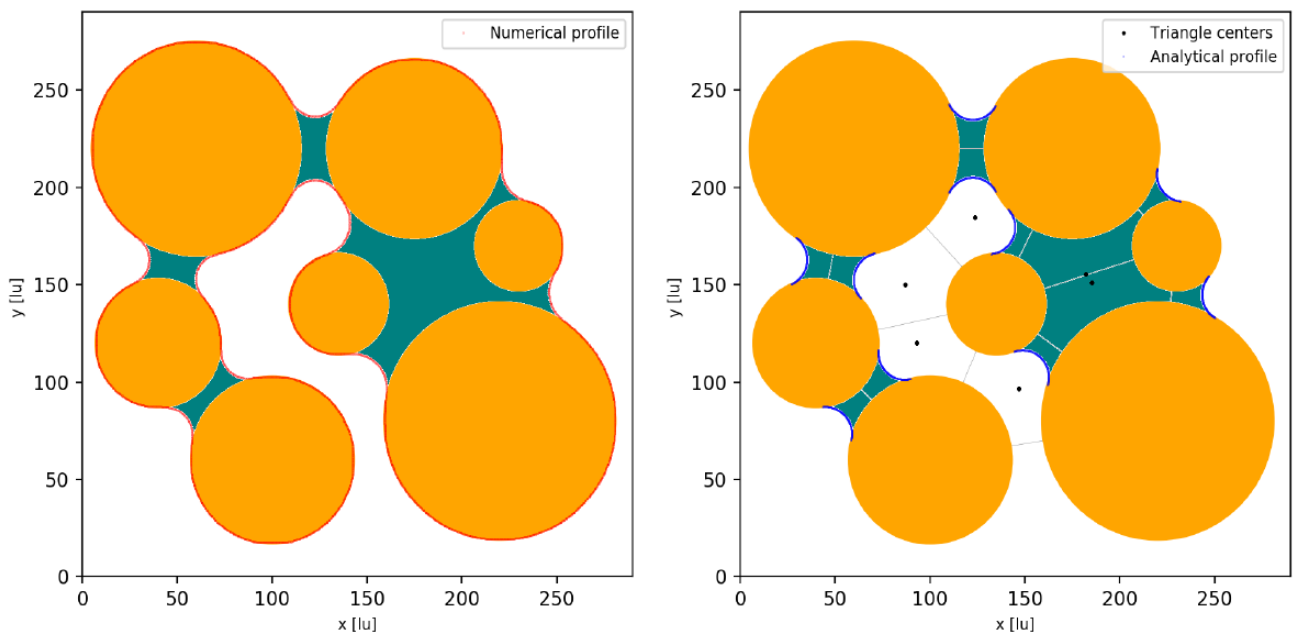

**Figure 3** Evolution of a 2D fluid cluster using the LBM on the left. On the right, the analytical model presented in this work. Qualitative agreement is observed between both interfaces.

## References

- Mason, G., & Morrow, N. R. (1984). Meniscus curvatures in capillaries of uniform cross-section. *Journal of the Chemical Society, Faraday Transactions 1: Physical Chemistry in Condensed Phases*, 80(9), 2375-2393.
- Shan, X., & Chen, H. (1993). Lattice Boltzmann model for simulating flows with multiple phases and components. *Physical Review E*, 47(3), 1815.

# DEM-RANS coupling with YADE: presentation and application to turbulent bedload transport

Raphael Maurin<sup>1</sup>, Julien Chauchat<sup>2</sup>, Philippe Frey<sup>3</sup>

<sup>1</sup> IMFT, Univ. Toulouse, CNRS, Toulouse, France

<sup>2</sup> LEGI, Univ. Grenoble Alpes, CNRS, Grenoble France

<sup>3</sup> Irstea, Univ. Grenoble Alpes, Grenoble, France

raphael.maurin@imft.fr

**Keywords:** DEM-RANS coupling; HydroForceEngine; turbulent bedload transport

YADE has recently been coupled with a 1-D volume-averaged fluid resolution in order to simulate turbulent bedload transport configurations (Maurin, 2015). The model has been detailed and compared to experiments (Maurin et al., 2015), and further applied to analyze the local granular rheology (Maurin et al., 2016), the slope influence (Maurin et al., 2018) and size-segregation (Frey et al., 2017) in turbulent bedload transport. The goal of this contribution is to present the fluid resolution and the corresponding tools implemented in YADE, and to give an idea on how it can be used in practice from examples of turbulent bedload transport simulations.

Fluid-particle flows are ubiquitous in nature and in industrial applications, as for example in sediment transport, pipe flow or fluidized bed processes. Large scale modeling for such applications represents a major issue, and remains a challenge considering the complexity of granular media and turbulent fluid flows. In this framework, it is worth adopting a particle-scale description in order to better understand the mechanisms at play and determine physically-based closures for larger scale model. Focusing on the granular phase description, this is achieved in the present contribution by considering a coupling between a discrete element method (DEM) and a volume-averaged fluid resolution (RANS). In such an approach, each particle is described independently using the DEM and considering the interaction with the solved averaged fluid velocity field. The momentum transfer associated to the fluid forces applied to the particles is accounted for in the fluid resolution, so that the momentum of the whole system is conserved.

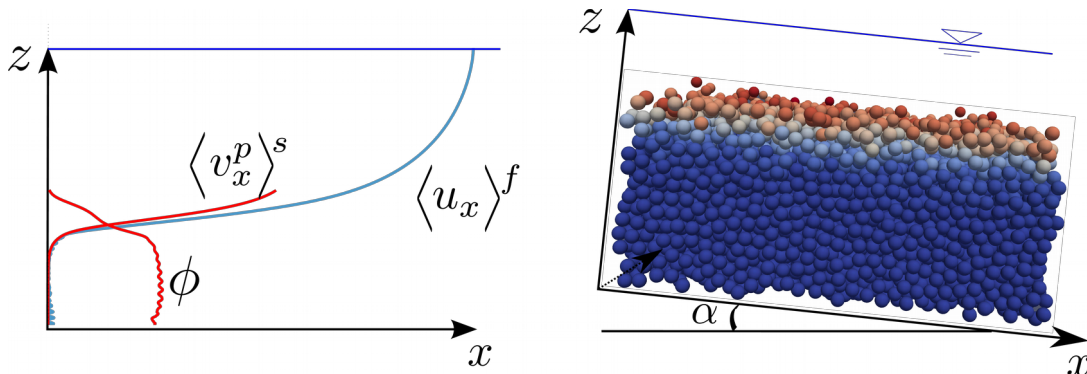

**Figure 1** Schematical description of the configuration considered for the DEM-1D RANS coupling

Considering steady uniform turbulent bedload transport, the volume-averaged fluid resolution reduces to a 1-D fluid momentum balance on the streamwise fluid velocity  $\langle u_x \rangle^f$  (Jackson, 2000; Maurin et al. 2015):

$$\epsilon \rho^f \frac{\partial \langle u_x \rangle^f}{\partial t} = \frac{d(\epsilon \langle \tau_{xz} \rangle^f)}{dz} + \frac{dR_{xz}^f}{dz} + \epsilon \rho^f g \sin \alpha - n \langle f_x \rangle^s, \quad (1)$$

where  $\epsilon = 1 - \phi$  is the fluid volume fraction,  $\phi$  is the solid volume fraction,  $\rho^f$  is the fluid density,  $\langle \mathbf{u}^f \rangle = \langle u_x \rangle^f(z) \mathbf{e}_x$  is the volume-averaged fluid velocity profile,  $\tau_{xz}$  and  $R_{xz}$  are the viscous and turbulent fluid stresses,  $g$  is the acceleration of gravity,  $\alpha$  is the channel inclination angle, and  $n \langle f_x \rangle^s$  is the momentum transfer associated to the fluid-particle interactions. To solve

equation (1), the latter and the solid volume fraction are determined by averaging the discrete particle phase.

The DEM-1D RANS coupling has been implemented in YADE through an engine named HydroForceEngine, which is able to (i) apply fluid forces to each particle from a 1-D fluid velocity profile  $\langle \mathbf{u}^f \rangle = \langle u_x \rangle^f(z) \mathbf{e}_x$ , (ii) compute the volume-averaged 1-D depth profiles of solid volume fraction, solid velocity and drag forces applied by the fluid to the particles, and (iii) solve equation (1) from the latter profiles, for a given time and with a given time-step.

When added to the engine list, the HydroForceEngine applies drag and buoyancy forces to each particle contained in the engine id list, with the following formulations:

$$\begin{aligned} \vec{f}_D^p &= \frac{1}{2} \rho^f \frac{\pi d^2}{4} C_D \left\| \langle \vec{u} \rangle_{x^p}^f - \vec{v}^p \right\| \left( \langle \vec{u} \rangle_{x^p}^f - \vec{v}^p \right), & C_D &= \left( 0.4 + \frac{24.4}{Re_p} \right) (1 - \phi)^{-\zeta}, \\ \vec{f}_b^p &= V^p \left( -\vec{\nabla} \langle P \rangle^f + \vec{\nabla} \cdot \langle \overline{\boldsymbol{\tau}}^f \rangle \right), \end{aligned} \quad (2)$$

where  $d$  is the particle diameter,  $v^p$  is the particle velocity,  $Re_p$  is the particle Reynolds number,  $\zeta$  is the Richardson-Zaki exponent,  $V^p$  is the particle volume, and  $P$  is the fluid pressure.

The function `averageProfile` of HydroForceEngine allows to compute the 1-D volume-averaged depth profiles of solid velocity, volume fraction, and drag force. The stored vectors are used for the fluid resolution, but the function can also be called independently.

Last, the function `fluidResolution` takes as parameters the simulated time and the fluid resolution time step. It solves a discretized version of equation (1), using implicit finite differences and solving the resulting tri-diagonal system with a double-sweep algorithm (see Maurin et al., 2015; and Chauchat, 2017). More details about HydroForceEngine, the corresponding functions and the different parameters can be found in YADE manual.

The example folder `trunk/example/HydroForceEngine` contains validation scripts of the fluid resolution (`fluidValidation`), diverse examples to show how HydroForceEngine can be used (`oneWayCoupling`), and a script to simulate steady uniform turbulent bedload transport configurations with the DEM-1D RANS coupling described above (`twoWayCoupling`). Those examples come with associated post-processing scripts. Focusing on the DEM-1D RANS coupling script (`sedimentTransportExample_1DRANSCoupling.py`), it allows tracking for example the sediment transport rate as a function of time, and to compute the solid depth profiles (Maurin et al. 2015) or the local granular rheology as a function of the depth from `getStressProfile` function (Maurin et al. 2016).

## References

- Chauchat, J. (2017) A comprehensive two-phase flow model for unidirectional sheet-flows, *Journal of Hydraulic Research*. DOI: 10.1080/00221686.2017.1289260
- Jackson R. (2000) The dynamics of fluidized particles, *Cambridge University Press*
- Frey P., Maurin R., Morchid-Alaoui L., Gupta S. and Chauchat J. (2017) Vertical size-segregation numerical experiments in bedload sediment transport with a coupled fluid-discrete element model, In proceedings *Powder and Grains 2017*
- Maurin R. (2015) Investigation of granular behavior in bedload transport using an Eulerian-Lagrangian model, PhD Thesis, Univ. Grenoble Alpes, 142pp
- Maurin R., Chauchat J., Chareyre B. and Frey P. (2015) A minimal coupled fluid-discrete element model for turbulent bedload transport, *Physics of Fluids* 27, 113302
- Maurin R., Chauchat J., Chareyre B. and Frey P. (2016) Granular rheology in turbulent bedload transport, *Journal of Fluid Mechanics* 804: 490-512
- Maurin R., Chauchat J., Chareyre B. and Frey P. (2018) Revisiting slope influence in turbulent bedload transport: consequence for vertical flow structure and transport rate scaling, *Journal of Fluid Mechanics*, 839: 135-156

## Acknowledgements

Raphael Maurin would like to thank the Yade community for support during the development.

## YADE simulations of vertical size-segregation in bedload sediment transport

Rémi Chassagne<sup>1</sup>, Philippe Frey<sup>1</sup>, Julien Chauchat<sup>2</sup>, Raphaël Maurin<sup>3</sup>

<sup>1</sup> Irstea, Univ. Grenoble Alpes, UR ETNA, St Martin d'Herès, France

<sup>2</sup> LEGI, Univ. Grenoble Alpes, CNRS UMR 5519 - Grenoble, France

<sup>3</sup> IMFT, Univ. Toulouse, CNRS - Toulouse, France

remi.chassagne@irstea.fr

**Keywords:** Bedload; Segregation; HydroForceEngine

Bedload sediment transport (transport of particles by a flowing fluid along the bed by rolling, sliding and/or saltating) has major consequences for public safety, water resources and environmental sustainability. In mountains, steep slopes drive intense transport of a wide range of grain sizes implying size sorting or segregation largely responsible for our limited ability to predict sediment flux and river morphology.

Concerning size sorting, most studies have concentrated on the spontaneous percolation of fine grains into immobile gravels. However when the substrate is moving, the segregation process is different as statistically void openings permit downward percolation of larger particles, a process also known as ‘kinetic sieving’.

In order to gain understanding of this process, bedload transport numerical experiments of two-size particle mixtures were carried out, using a coupled Eulerian-Lagrangian fluid-discrete element model developed at Irstea and validated with experiments (Maurin et al. 2015, 2016). It is composed of a 3D discrete element model (based on the open source code Yade), describing each individual particle, coupled with a one dimensional Reynolds average Navier Stokes model (Chauchat 2017) (HydroForceEngine module in YADE). A 3D 10% steep domain (angle of 5.71°) consisting at initial time of a given number of layers of 4 mm spherical particles deposited on top of a 6 mm particle bed, were submitted to a turbulent, hydraulically rough and supercritical water flow and let evolved with time. Shields numbers (dimensionless water shear stress) of 0.1 and 0.3 were considered.

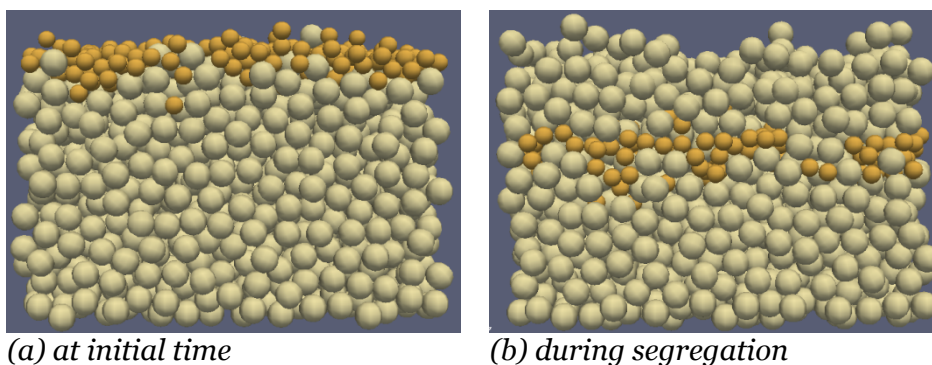

**Figure 1** Segregation simulation with YADE. The fine particles infiltrate inside the bed formed by the coarse particles

For a given Shields number, the elevation of the center of mass of the infiltrated fine particles has been shown to remarkably follow the same logarithmic decrease with time, whatever the number of fine layers initially deposited. This decrease is steeper for a higher Shields number.

These numerical experiments were also analysed in the framework of a continuum theoretical model for the segregation of binary mixtures based on a kinematic approach (Thornton

et al. 2006). Modelling bedload size sorting at the particle scale and upscaling in continuum models should improve our knowledge of sediment transport and river morphology.

### **References**

- Chauchat J. (2017) A comprehensive two-phase flow for unidirectional sheet-flows. *Journal of Hydraulic Research*: 10.1080/00221686.2017.1289260
- Maurin R, Chauchat J, Chareyre B, Frey P. 2015. A minimal coupled fluid-discrete element model for bedload transport. *Physics of Fluids* 27(11): 113302.
- Maurin R, Chauchat J, Frey P. 2016. Dense granular flow rheology in turbulent bedload transport. *Journal of Fluid Mechanics* 804: 490-512.
- Thornton AR, Gray J, Hogg AJ. 2006. A three-phase mixture theory for particle size segregation in shallow granular free-surface flows. *Journal of Fluid Mechanics* 550: 1-25.

## Simulation of Dense Granular Suspension

Lhassan Amarsid<sup>1</sup>, Jean-Yves Delenne<sup>2</sup>, Yann Monerie<sup>1</sup>, Frederic Perales<sup>3</sup> & Farhang Radjai<sup>1</sup>

<sup>1</sup> LMGC, CNRS-University of Montpellier, 163 rue Auguste Broussonnet, 34090 Montpellier, France

<sup>2</sup> IATE, UMR1208 INRA - CIRAD - University of Montpellier - SupAgro, 34060 Montpellier, France

<sup>3</sup> IRSN, PSN, CE Cadarache, BP3-13115 St Paul-Lez-Durance Cedex, France

lhassan.amarsid@umontpellier.fr

**Keywords:** immersed granular materials; numerical modeling; dense suspension; Lattice Boltzmann

The shear behavior of granular materials immersed in a viscous fluid depends on fluid properties (viscosity, density), particle properties (size, density) and boundary conditions (shear rate, confining pressure). Using computational fluid dynamics simulations coupled with molecular dynamics for granular flow, and exploring a broad range of the values of parameters, we show that the parameter space can be reduced to a single parameter that controls the packing fraction and effective friction coefficient. This control parameter is a modified inertial number that incorporates viscous effects.

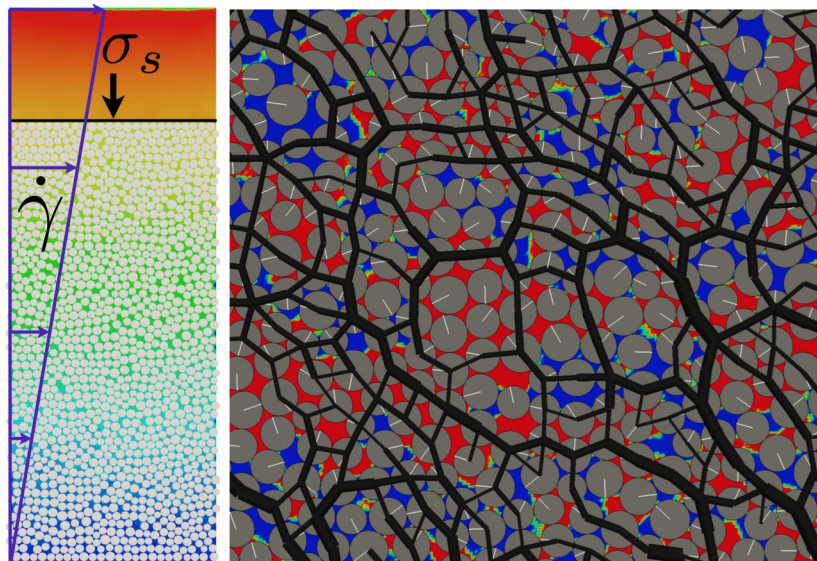

**Figure 1** A snapshot of the suspension and its boundary conditions (left); a snapshot of the force network and negative and positive fluid pressures in blue and red, respectively.

# Suffusion micro-mechanisms through DEM/PFV simulations

Antoine Wautier<sup>1,2,3</sup>, François Nicot<sup>3</sup>, Stéphane Bonelli<sup>2</sup>

<sup>1</sup> AgroParisTech-ENGREF, 19 avenue du Maine, 75732 Paris, France

<sup>2</sup> Irstea UR RECOVER, 3275 Rte Cézanne, CS 40061, 13182 Aix-en-Provence Cedex 5, France

<sup>3</sup> Université Grenoble Alpes, Irstea UR ETGR, 2 rue de la Papeterie-BP 76, F-38402 St-Martin-d'Hères, France  
antoine.wautier@irstea.fr

**Keywords:** internal erosion ; instabilities ; DEM ; PFV

Suffusion is the selective erosion of the finest particles of a granular material subjected to an internal flow. Among the four kinds of internal erosion processes identified today, it is the only one that can be considered at the material point scale. Indeed, the internal flow modifies the microstructure as a whole. Consequently, the effect of suffusion on a granular material may be seen as a modification of the constitutive properties of the material itself and not as a boundary value problem. This fundamental remark enables to analyse the elementary mechanisms of suffusion at the scale of a representative elementary volume (REV) of soil.

In this study, granular materials are modelled at the REV scale using the open source code YADE based on a discrete element method (DEM). In addition to standard contact forces, fluid/grain interactions are accounted for with a recently developed pore scale finite volume (PFV) scheme (Chareyre et al. 2012). Based on the full coupled problem, the impact of the fluid flow in terms of grain erosion, grain clogging and force chain reorganization is explored numerically at the microscale. This analysis relies mostly on recently developed micromechanical tools based on force chain and pore network definitions (Wautier et al. 2017). In parallel, the flow impact is assessed at the REV scale in terms of mechanical stability according to the second order work criterion (Nicot et al. 2009). The elementary mechanisms are shown to have different impacts on the evolution of the bifurcation domain. In particular, clogging might play an unexpected stabilizing role.

In addition to the above considerations, details on the numerical modelling will be given and the issue of computational cost will be raised. In particular, the choice in the boundary conditions, the definition of an erosion criterion and the size of the sample in terms of particle size distribution and number of particles will be discussed.

## References

- Chareyre B., Cortis A., Catalano E. and Barthélemy E. (2012) Pore-scale modeling of viscous flow and induced forces in dense sphere packings. *Transp. Porous Media* 94(2), 595–615.
- Nicot F., Sibille L. and Darve F. (2009) Bifurcation in granular materials: An attempt for a unified framework. *International Journal of Solids and Structures* 46 (22), 3938–3947.
- Wautier A., Bonelli, S. and Nicot F. (2017) Scale separation between grain detachment and grain transport in granular media subjected to an internal flow. *Granular Matter* 19 (2), 22.



## DEM Model and Suffusion-like Simulations

Rodaina Aboul Hosn<sup>1</sup>, Luc Sibille<sup>2</sup>, Nadia Benahmed<sup>1</sup>, Bruno Chareyre<sup>2</sup>

<sup>1</sup> IRSTEA, Research Unit Recover, 13182 Aix-en-Provence cedex 5, France

<sup>2</sup> Université Grenoble Alpes, CNRS, Grenoble INP, 3SR, F-38000 Grenoble, France  
rodaina.aboul-hosn@irstea.fr

**Keywords:** Internal erosion; suffusion; discrete element method; fluid-solid coupling; soil's microstructure.

Suffusion is a particular internal erosion process that can lead to important disorders in water retaining structures such as embankment dams and levees. Therefore, the aim of this study is to further investigate the mechanical behavior of erodible soils and their microstructure. We present such an investigation through a numerical study based on the discrete element method (DEM). The discrete numerical model used in this study consists of a 3D granular assembly modeled with spherical discrete elements (Aboul Hosn et al. 2017). Previous studies from the literature showed that such a simplified particles' shape leads to excessive rolling, limiting the mechanical resistance of the soil. Thus, contact rolling resistance is taken into consideration in this work to model the grain's angularity and to better represent the macroscopic behavior of granular materials. The influence of elastic and plastic local parameters will be discussed. Moreover, a procedure to obtain an initial density, ranging from loose to dense samples, is proposed and a calibration procedure based on all these considerations is defined. Thereafter, a numerical extraction procedure developed in this study to mimic the suffusion process is presented (Aboul Hosn et al. 2018). Suffusion constitutes a strongly coupled fluid-solid interaction problem. Seepage flow through the porous medium exerts forces on soil particles leading to their displacement which in turn affects the fluid flow. Thus, only a fully coupled hydro-mechanical model is capable of describing such a complex process. However, using a complete hydro-mechanical coupling approach constitutes a difficult task which requires an important computational cost. Therefore, the newly developed extraction procedure presents an alternative and original approach based on a one-way fluid-solid coupling which allows taking into account both hydraulic and geometric criteria to describe the detachment and the migration of fine particles with a reasonable computational cost. All details of the new approach are discussed. Moreover, the defined extraction procedure is applied on a soil sample and the consequences of suffusion on the mechanical properties of the soil are characterized. A microstructural analysis of eroded soils is then considered to better understand how the microstructure of the soil is modified after suffusion.

### References

- Aboul Hosn R., Sibille, L., Benahmed N., and Chareyre B. (2017). Discrete numerical modeling of loose soil with spherical particles and interparticle rolling friction. *Granular matter*, doi:10.1007/s10035-016-0687-0, 19:4.
- Aboul Hosn R., Sibille L., Benahmed N., and Chareyre B. (2018). A discrete numerical model involving partial fluid-solid coupling to describe suffusion effects in soils. *Computers and Geotechnics*, 95:30-39.

## Heat conduction in polydisperse granular media

Duc Hanh Nguyen<sup>1,2,3</sup>, Bruno Collard<sup>3</sup>, Émilien Azéma<sup>1</sup>, Philippe Sornay<sup>2</sup>, Farhang Radjai<sup>1</sup>

<sup>1</sup> Laboratoire de Mécanique et Génie Civil, Université de Montpellier, 34000, Montpellier, France

<sup>2</sup> CEA/DEN/DEC/SFER/LCU, F-13108, Saint Paul lez Durance, France

<sup>3</sup> CEA/DEN/DEC/SESC/LSC, F-13108, Saint Paul lez Durance, France  
frank.radjai@umontpellier.fr

**Keywords:** granular media; polydisperse; heat transfer; Discrete Element Method; PFV

We investigate the heat conductivity of granular samples as a function of the distribution of particle sizes. A thermal model embedded in a discrete element scheme is used for this study. Several granular samples are built, from mono-disperse to very polydisperse (Figure 1). We find that the thermal conductivity increases first and then decreases with size span for a uniform distribution of particle volume fractions (Figure 2). This behavior is the reflect of the volume fraction of particles which contributes to the heat transfer network. The characteristics of the systems such as the volume fraction, the contact network, the forces, the local heat flux and the path of heat are analyzed. The variation of thermal conductivity with particle size span is a consequence of two contradictory effects: As the size span increases, the path of heat becomes shorter, and the average force and thus the heat flux at the contacts increase, thus enhancing the heat transfer. On the other hand, for a granular media of high size span, we observe a large number of floating particles thus excluded from the heat transfer network, with a significant decrease in the number of contacts.

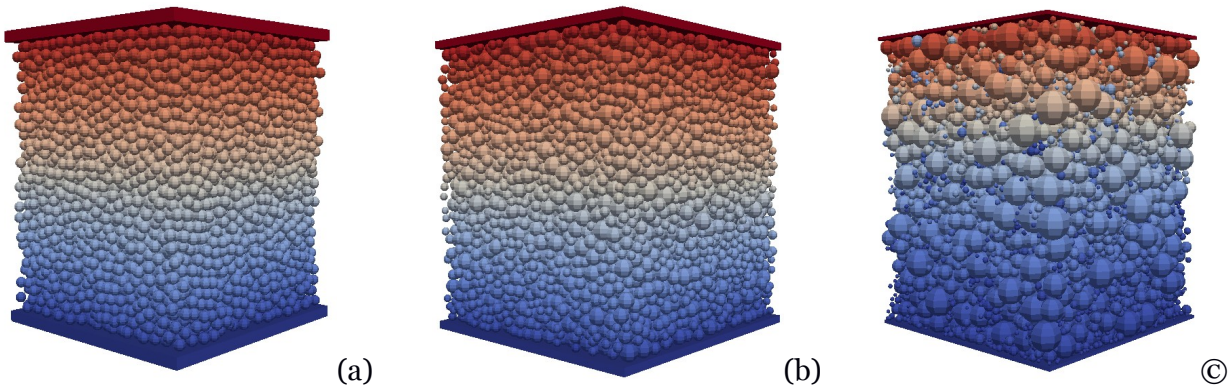

**Figure 1:** Temperature distribution in assemblies for different size spans  $s$ . Here, for  $s=0.0$  (a),  $s=0.4$  (b) and  $s=0.8$  (c)

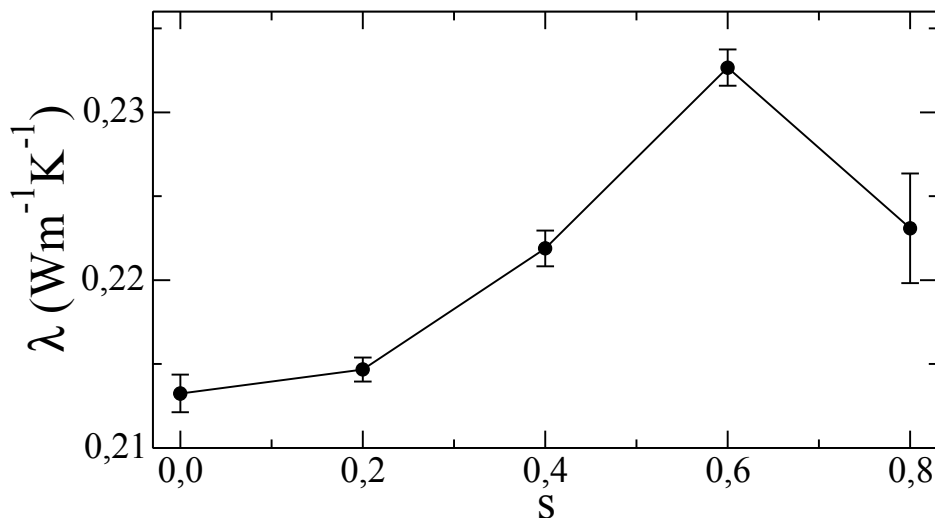

**Figure 2:** Effective thermal conductivity as a function of size span  $s$

## Combined DEM-FEM Modeling of Shot Peening Process

Dhanooj Bobba<sup>1</sup>, Praveen Ramaprabhu<sup>1</sup>, Harish P. Cherukuri<sup>1</sup>  
<sup>1</sup> Department of Mechanical Engineering and Engineering Science  
 UNC Charlotte, Charlotte, NC 28223-0001, USA  
 hcheruku@uncc.edu

**Keywords:** Shot peening; Almen intensity; DEM; FEM

Shot peening is a surface hardening technique used to improve the fatigue life of metallic components in a wide variety of industries such as aerospace, energy generation and automotive. It involves projection of a large number of small spherical particles with high velocities onto the target surfaces. Due to the impact, the surfaces deform plastically and develop compressive residual stresses that resist the development of cracks and thereby increasing the fatigue life of the components significantly.

The effectiveness of the peening process is mainly controlled by two factors, namely coverage area and intensity. The intensity of the shot peening process is measured using a special technique known as the Almen intensity test, where a thin strip is shot peened by fixing it on to a holder and when the constraints are removed, the strip bends forming an arc like structure. The height of the resulting arc is used as an indirect measure for the intensity of the shot peening process, also known as Almen intensity. Various numerical studies have been made to accurately model the shot peening process and to study the effects of peening parameters on the development of the residual stresses (Schulze et al., 2008). But due to the complexity of the process, the models were limited to few number of shots with pre-selected impact locations. To develop a full-scale model, particle methods have been used but are limited to the study of shot stream dynamics (Jianming et al., 2011) and (Murugaratnam et al., 2015). The purpose of our study is to develop a realistic model of the shot peening process that more accurately simulates the Almen intensity tests and that can be used for studying the impact of various process parameters on Almen intensity.

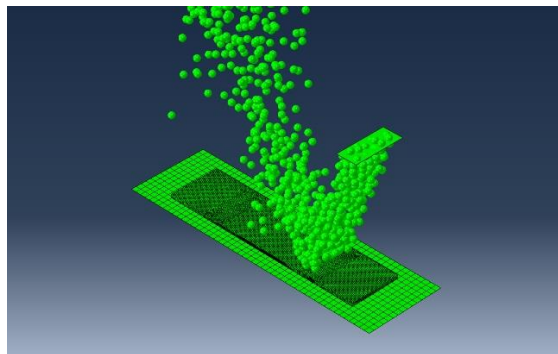

**Figure 1.** Almen intensity test with shots modeled as DEM particles.

The shot peening model uses the discrete element method coupled with the finite element method. The shots are modeled as DEM particles and the strip and supporting structure are modeled using finite elements in Abaqus\Explicit. The DEM particles are generated using the top plate in Figure 1, also known as the particle generator. The mass flow rate and the velocity of the flow are defined. The Almen strip is modeled using Johnson Cook parameters with strain rate dependency. The resulting arc height of the Almen strip is obtained by transferring the results from Abaqus\Explicit to Abaqus\Standard. The influence of the shot velocity, size and the angle of impact on the Almen intensity have been studied.

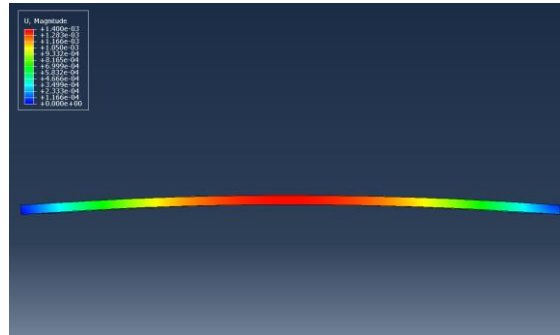

**Figure 2.** Arc height of the Almen strip due to shot peening.

### **References**

- Jianming W., Feihong L., Feng Y. and Gang Z. (2011) *Shot peening simulation based on SPH method*, The International Journal of Advanced Manufacturing Technology, 56(5-8), pp. 571-578
- Murugaratnam K., Utili S. and Petrinic N. (2015) *A combined DEM-FEM numerical method for Shot Peening parameter optimization*, Advances in Engineering software, 79, pp. 13-26.
- Schulze V., Klemenz M. and Zimmermann M. (2008) *State of the art in shot peening simulation*, In: 10<sup>th</sup> International Conference on Shot Peening, pp. 15-18.

# DFNFlow Engine: Hydraulic fracturing and progressive failure in saturated low permeability quasi brittle materials

Efthymios Papachristos<sup>1</sup>, Luc Scholtès<sup>2</sup>, Frédéric Donzé<sup>3</sup>, Bruno Chareyre<sup>4</sup>

<sup>1</sup>Université Paris-Est, Laboratoire Navier (UMR 8205), CNRS, ENPC, IFSTTAR, F-77455 Marne-la-Vallée cedex 2, France

<sup>2</sup>Université de Lorraine, CNRS, GREGU, Laboratoire GeoRessources, 54500 Vandoeuvre-lès-Nancy, France

<sup>3</sup> Université Grenoble-Alpes, CNRS, IsTerre, CS 40700, 38058 Grenoble cedex 9, France

<sup>4</sup>Université Grenoble-Alpes, CNRS, 3SR, F-38000 Grenoble, France

efthymios.papachristos@enpc.fr

**Keywords:** Hydraulic Fracturing; Dual Permeability; Rock Mechanics; Progressive Failure; Hydromechanical Coupling

A detailed modelling of hydraulic fracturing is becoming vital for the sustainable development of enhanced geothermal systems and fossil fuel extraction as well as for understanding important phenomena related to naturally induced hydraulic fractures. The great majority of existing models are restricted to the simulation of single, non-interacting hydraulic fractures in homogeneous media and are most of the times formulated in two dimensions. However, the inhomogeneity of the rock, the potential and very probable interaction between hydraulic fractures and natural fractures or neighbouring hydraulic fractures as well as the 3<sup>rd</sup> spatial dimension are key aspects for the hydraulic fracture growth.

In an attempt to gain insight into hydraulic fracturing processes taking place in low permeability, non-homogeneous cohesive media, a hydro-mechanical DEM model was developed. The proposed model is based on the bonded particle method (BPM) specifically developed for rock modelling purpose (Scholtès & Donzé, 2013). Through the possibility to adjust the degree of particle interlocking in relation with the texture of the material under consideration, the BPM can reproduce non-linear macroscopic failure envelopes as well as high UCS/UTS ratios as an alternative to clumps or computationally heavier constitutive laws. The fluid flow is modelled through the PFV scheme (Chareyre et al., 2012, Catalano et al., 2014) specifically modified for double permeability, cohesive materials (Papachristos, 2017, Papachristos, et al., 2017). The fluid space corresponds to the physical geometrical space between the discrete elements. Local conductances between adjacent “pores” are based on the Hagen-Poiseuille law if the rock is intact or on the cubic law if a crack exists between the pores. The above configuration leads to a two way coupling between fluid flow, rock deformation and fracture opening (or closure).

The model has been applied in a number of applications including single and multiple hydraulic fractures propagation in intact rock specimen (Figure 1) as well as in specimen containing persistent and non-persistent natural fractures (Figure 2). From the analysis many important aspects arose regarding the spatio-temporal hydraulic fracture growth, its intensity and volume.

The model, after detailed verification could open the way for tackling a large variety of hydro-mechanical problems related to rocks or other tight permeability brittle and quasi-brittle media.

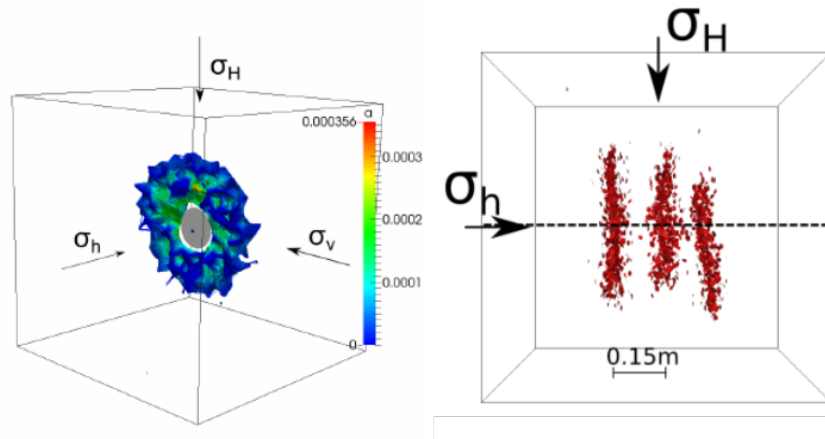

**Figure 1** (Left) 3D view of aperture distribution on single hydraulic fracture. (Right) Side view of final patterns of three closely spaced, sequential hydraulic fractures.

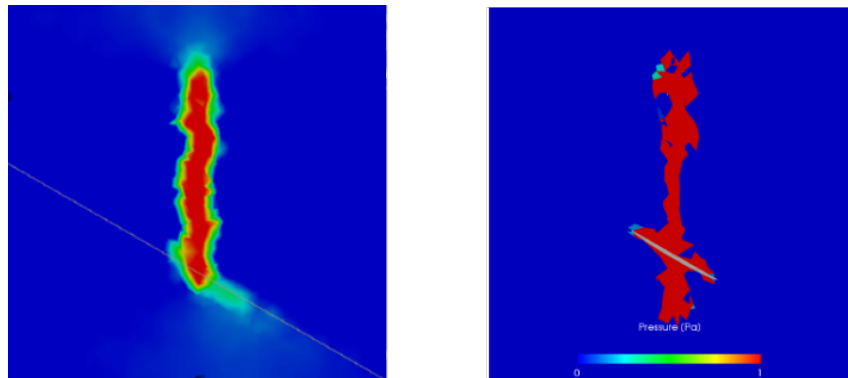

**Figure 2** (Left) Volumetric strain (dilation) due to propagating hydraulic fracture in specimen with a persistent discontinuity. (Right) Binary pressure field demonstrating crossing of the pre-existing defect by the hydraulic fracture.

## References

- Catalano, E., Chareyre, B. and Barthélemy, E., 2014. Pore-scale modeling of fluid-particles interaction and emerging poromechanical effects. *International Journal for Numerical and Analytical Methods in Geomechanics*, 38(1), pp.51-71.
- Chareyre, B., Cortis, A., Catalano, E. and Barthélemy, E., 2012. Pore-scale modeling of viscous flow and induced forces in dense sphere packings. *Transport in porous media*, 94(2), pp.595-615.
- Papachristos, E., 2017. *A 3D hydro-mechanical discrete element model for hydraulic fracturing in naturally fractured rock* (Doctoral dissertation, Grenoble Alpes).
- Papachristos, E., Scholtès, L., Donzé, F.V. and Chareyre, B., 2017. Intensity and volumetric characterizations of hydraulically driven fractures by hydro-mechanical simulations. *International Journal of Rock Mechanics and Mining Sciences*, 93, pp.163-178.
- Scholtès, L. and Donzé, F.V., 2013. A DEM model for soft and hard rocks: role of grain interlocking on strength. *Journal of the Mechanics and Physics of Solids*, 61(2), pp.352-369.

# Modelling of hydraulic fracturing in rocks using VPN fluid flow model in coupled DEM/CFD approach

Marek Krzaczek<sup>1</sup>, Janek Kozicki<sup>1</sup>, Jacek Tejchman<sup>1</sup>  
<sup>1</sup> Gdańsk University of Technology, 80-233 Gdańsk, Poland  
 mkrzacze@pg.edu.pl, jkozicki@pg.edu.pl, tejchmk@pg.edu.pl

**Keywords:** CFD; Virtual Pore Network; Hydraulic Fracturing; Deformable Spheres

Hydraulic fracturing is a stimulation technique used to increase the productivity of petroleum reservoirs in which rocks are fractured by a pressurized liquid. The process involves the high-pressure injection of fluid with proppants into a wellbore to create cracks in the deep-rock formations through which natural gas and petroleum will flow more freely. When the hydraulic pressure is removed from the well, small proppant grains remain to hold the fractures open.

The modeling of the fluid-driven fracture initiation and propagation in rocks comprises the coupling of different physical mechanisms: (1) large deformation of the solid skeleton induced by the fluid pressure on fracture surfaces and (2) flow of the pore fluid along new fractures and through the region of surrounding existing fractures. Hydraulic fracturing results in very complex fracture patterns composed of pre-existing and new fractures that greatly influence the process at the global scale. Since hydraulic fracturing strongly depends on heterogeneous rocks' meso-structure the DEM is a suitable numerical tool for investigating the formation process of complex fracture patterns at the mesoscopic level (Suchorzewski et al. 2017).

The aim of our research work is to develop a novel model of the fluid-driven fracture initiation and propagation in rocks based on the three-dimensional DEM that combines mechanics of discontinuous bodies with fluid dynamics. Here, the Virtual Pore Network (VPN) fluid flow model coupled with DEM is proposed. The VPN model is a significant extension of Pore Network (also called Pore Finite Volume) method (Yoon et al. 2014, Shimizu et al. 2011). The basic concept of VPN is to reproduce geometry of voids (fluid domain) in the rock matrix. The fluid domain is discretized by using the mesh of triangular (2D) or tetrahedral (3D) cells further called virtual pores.

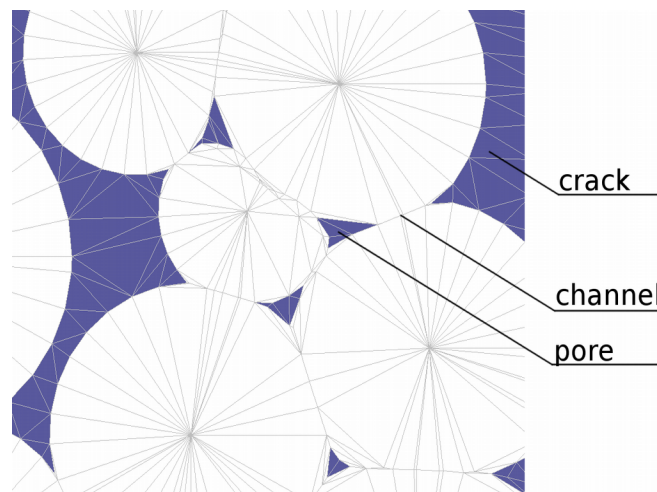

**Figure 1** Example mesh in 2D with large grain deformations at the grain-scale level.

Full detailed treatment of geometry is performed at the level of grain scale both in 2D (Fig. 1) and 3D. The DEM model is extended to account for geometrical deformation of DEM elements, since soft-sphere approach in which spheres overlap does not make it possible to precisely capture the pore geometry. The channels, pores and fracture geometry follow the changing geometry of DEM grains deformations. The remeshing is performed to account topological DEM changes due to formation or closing of cracks. This is achieved by overlapping the affected regions of old mesh over the new mesh to find the exact geometrical overlapping volume between each virtual pore element from new grid with respective virtual pore elements in the old

grid. An exact change of two-phase pore pressure is recalculated according to contributions of volume from the old elements to the new elements in the new mesh. This results in complete change of mesh topology, including formation and destruction of pores, cracks and channels. Furthermore to improve the algorithm accuracy the change of pores/channels into cracks and vice-versa will be accounted for by using full energy, momentum and mass preserving system of nonlinear equations.

It is assumed that fluid flows only through the channels which connect centroids of virtual pores. To model fluid flow in the channels, the Poiseuille fluid flow model is applied. In general, the voids in the rock matrix can be filled with a multi-phase fluid, partly with gas phase and partly with liquid phase. Thus, a full multi-phase fluid flow model is assumed. The Volume of Fluid method is implemented to track the liquid-gas interface. The fluid flows in the channels connecting virtual pores, while the virtual pores accumulate pressure and the volume fraction of each of the fluids. The interaction between discrete and continuum media is modeled by the mutual transfer of viscous and pressure forces from fluid to grains and by transfer of grains velocities from grains to fluid. Special attention is paid to the effect of rapid crack growth and displacements of the rock meso-structure on the fracture patterns and fluid pressures. The algorithm is based on an assumption that mass is a topological invariant. It enables to investigate fluid flow in a topologically variable pores and fractures system in which some pores, fractures and channels may vanish while some new others may appear.

The fully coupled hydro-mechanical 3D DEM/CFD model for rocks with pre-existing and newly created fractures will be implemented into the open source platform YADE (Kozicki & Donze 2008, Šmilauer V., Chareyre B., et al. 2011). At present a 2D version is working and a code rewrite to full 2D/3D is in progress. The DEM/CFD model will be validated based on the tests listed in the research literature.

## References

- Kozicki J. and Donze F.V. (2008) A new open-source software developed for numerical simulations using discrete modeling methods. *Comput. Methods Appl. Mech. Eng.* 197, 4429–4443.
- Shimizu H., Murata S. and Ishida T. (2011) The distinct element analysis for hydraulic fracturing in hard rock considering fluid viscosity and particle size distribution. *International Journal of Rock Mechanics & Mining Sciences* 48, 712-727.
- Suchorzewski J., Tejchman J. and Nitka M. (2017) Discrete Element Method simulations of fracture in concrete under uniaxial compression based on its real internal structures. *International Journal of Damage Mechanics*, doi: 10.1177/1056789517690915.
- Šmilauer V., Chareyre B., et al. (2011) Yade DEM Formulation. Manual, <http://yade-dem.org/doc/formulation.html>
- Yoon J. S., Zang A. and Stephansson O. (2014) Numerical investigation on optimized stimulation of intact and naturally fractured deep geothermal reservoirs using hydro-mechanical coupled discrete particles joints model. *Geothermics* 52, 165–184.

## Acknowledgements

The 2<sup>nd</sup> author thanks warmly the organizers for organizing this 2<sup>nd</sup> YADE Workshop.



# Micromechanical modeling of acoustic emissions using strain energy and numerical wave propagation in heterogeneous rocks

Robert Caulk<sup>1</sup>

<sup>1</sup> University of California, San Diego, 92122, La Jolla, California  
rcaulk@eng.ucsd.edu

**Keywords:** Acoustic Emissions; rock heterogeneity; wave propagation; micromechanics

A micromechanical investigation of acoustic emissions (AE) in heterogeneous rocks is performed. First, the heterogeneity model of a sandstone rock is developed and imposed on a Yade DEM specimen using cathodoluminescent image analysis (Figure 1). Next, the strain energy change AE simulation model developed by Hazzard et al. (2000) and Hazzard and Damjanac (2013) are added to Yade and validated experimentally (Figure 2). Finally, an array of numerical AE “transducers” is used to collect numerical wave propagation associated with broken bonds (Figure 3). The arrival times of these waves are used to localize the source event and strain energy based AE locations are used to validate the method. A relationship is established between numerical wave arrival time and dynamic heterogeneity, damping magnitude, and intrinsic heterogeneity. We find that the development of dynamic heterogeneity (damage) results in greater AE localization error due to the increased presence of frictional bonds. Damping magnitude plays a minor role in the collection and identification of numerical waves due to the application of low band pass filtering. As intrinsic heterogeneity increases, the localization error also increases due to an anisotropic velocity structure.

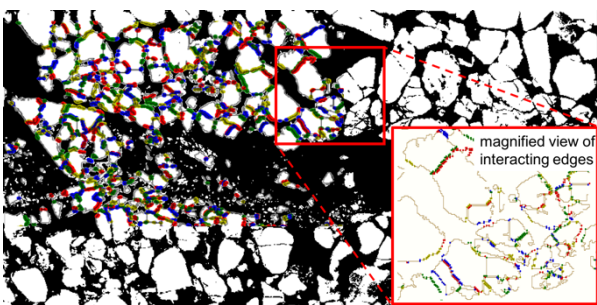

**Figure 1** Cathodoluminescent image analysis used to build a grain edge-interaction-length distribution for the heterogeneity model implemented in Yade (Caulk 2018)

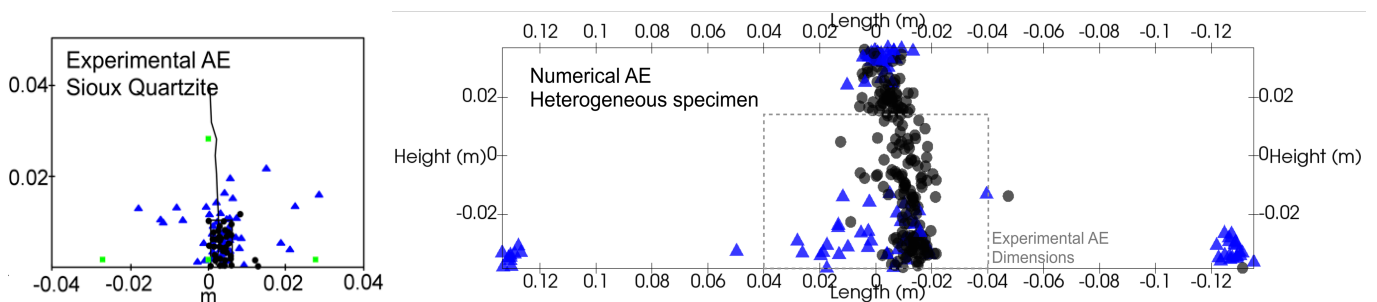

**Figure 2** DEM strain energy based Acoustic Emissions at 90-95% peak load (blue triangles) and 95-100% peak load (black circles) for a heterogeneous rock (Caulk 2018)(right). AE model and heterogeneity model both validated using Zietlow and Labuz (1998) data (left).

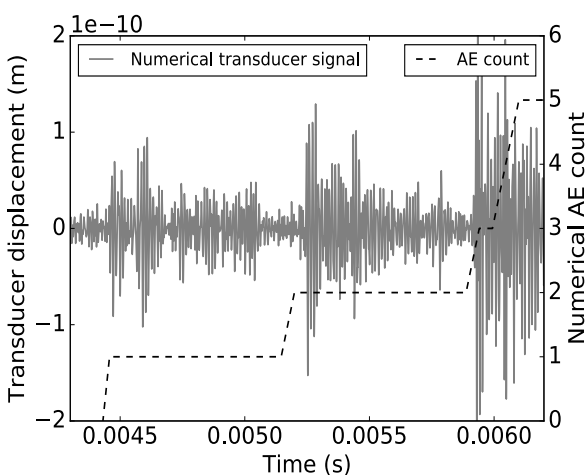

**Figure 3** Comparison of DEM synthetic wave to micromechanical strain energy based AE count. Synthetic waveforms arrive shortly after the strain based AE occur in the specimen, exhibiting the direct connection between micromechanical sources and realistic wave propagation

**References**

- Caulk, R. (In preparation, 2018) Stochastic augmentation of a discrete element model for the investigation of tensile rupture in heterogeneous rock.
- Hazzard, J., & Young, R. . (2000). Simulating acoustic emissions in bonded-particle models of rock. *International Journal of Rock Mechanics and Mining Sciences*, 37(5), 867–872.  
[http://doi.org/10.1016/S1365-1609\(00\)00017-4](http://doi.org/10.1016/S1365-1609(00)00017-4)
- Hazzard, J. F., & Damjanac, B. (2013). Further investigations of microseismicity in bonded particle models. *3rd International FLAC/DEM Symposium*, 1–11.
- Zietlow, W. K., & Labuz, J. F. (1998). Measurement of the Intrinsic Process Zone in rock using acoustic emission. *Int. J. Rock Mech. Min. Sci.*, 35(3), 291–299.  
[http://doi.org/10.1016/S0148-9062\(97\)00323-9](http://doi.org/10.1016/S0148-9062(97)00323-9)

# DEM and FEM Modeling of Uniaxial and Triaxial Compressive Behavior of Plain Concrete

Anay Joshi<sup>1</sup>, Nakul Tannu<sup>1</sup>, Rafael Aguilar<sup>2</sup>, Harish P Cherukuri<sup>1</sup>, Miguel A. Pando<sup>3</sup>

<sup>1</sup> Mechanical Engineering & Engineering Science, UNC Charlotte, Charlotte, NC, USA

<sup>2</sup> Civil Engineering, Pontificia Universidad Católica del Perú (PUCP), Lima, Perú

<sup>3</sup> Civil & Environmental Engineering, UNC Charlotte, Charlotte, NC, USA  
mpando@uncc.edu

**Keywords:** Uniaxial; Triaxial; Compressive response; FEM; DEM.

Concrete is a widely used material in civil infrastructure. Traditional analysis and design typically considers only the uniaxial behavior of the material. Predicting the stress-strain response of plain concrete under uniaxial compression is not trivial. A large number of structural elements involve concrete material under a multiaxial compressive state where the effect of the confining stress can be very important for design. The numerical prediction of the multiaxial compressive stress-strain behavior of plain concrete is more involved. In this presentation we will present results from an experimental program by Flores and Pando (2008) where triaxial compression tests were performed to assess the stress-deformation behavior and damage patterns of concrete under multiaxial compression. The authors will also present numerical predictions carried out using the finite element method (FEM) using several constitutive models. This will serve the purpose to highlight the challenging nature of this problem. Finally the authors will show numerical predictions performed using the Discrete element method (DEM) (Cundall & Strack, 1979). The initial set of DEM models were performed by Tannu (2017) using LS-Dyna (LSTC, 2017) (Figure 1a). The second set of DEM analyses are being modeled in YADE (Šmilauer et al., 2015). An example of one of the DEM models used is shown in Figure 1b.

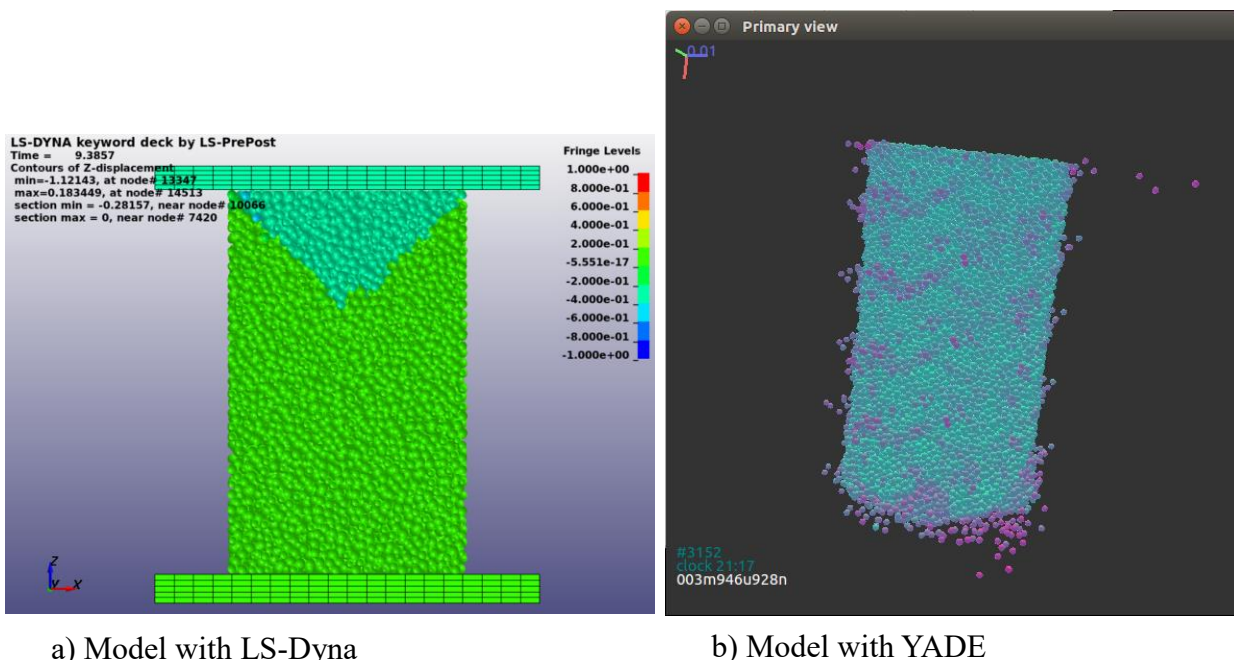

**Figure 1** Examples of DEM models used for uniaxial compression of plain concrete

The FEM and DEM models were used to predict uniaxial and triaxial compression experiments on plain concrete by Flores and Pando (2008). Uniaxial compression test results from this study are shown in Figure 2. This figure shows the axial compressive stress versus axial strain and also as a function of radial strain.

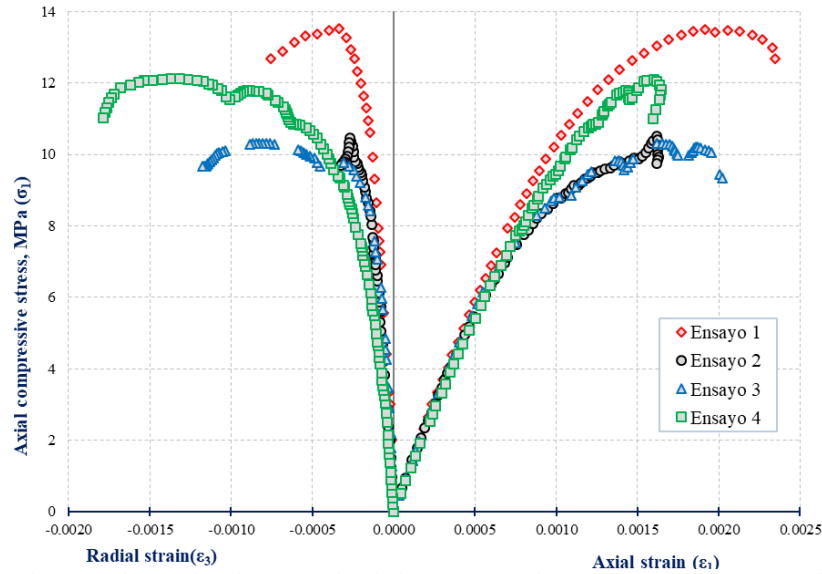

**Figure 2** Experimental results from uniaxial compression tests by Flores and Pando (2008).

FEM predictions were performed using the software TNO Diana and the constitutive laws Total Strain Crack Model (Vecchio and Collins, 1993) and UBCSAND (Puebla et al., 1997). The FEM predictions were found to be quite sensitive to the constitutive model used (Chinchay-Poma, 2017). The approach involved calibrating the different FEM models considered with the uniaxial compression test results and then perform blind predictions of the triaxial compression tests. The FEM models of the triaxial compression tests did a reasonably good job at predicting the compressive strength values, and were less accurate at predicting the volumetric strains that the specimens experienced during triaxial compression testing.

The DEM predictions, which is the focus of this presentation, also required a careful calibration as results are sensitive to particle size and shape, initial packing density, and the type of contact model used. Similarly to the FEM modeling, the DEM models were calibrated using the uniaxial compression test results. The DEM results to date show that this numerical approach can adequately predict the measured compressive strengths. The DEM prediction of the axial strain to failure, and the volumetric change is more sensitive to the variables mentioned above as reported by Tannu, 2017). The DEM modeling using YADE is ongoing to carefully investigate the effect of bond parameters, initial packing density, and other key variables. The authors will present FEM and DEM predictions for the purposes of comparison and to discuss key differences in initial model setup and general challenges of these two well established modeling approaches.

## References

- Chinchay-Poma, D.A. (2017). Finite element analyses of plain concrete under uniaxial and triaxial compression. MS thesis, PUCP, Lima, Peru.
- Cundall P.A. and Strack O. D. L. (1979) A discrete numerical model for granular assemblies, *Géotechnique* 29:1, 47–65
- Flores, O. and Pando, M. (2008). Triaxial experiments on plain concrete. University of Puerto Rico at Mayaguez, Civil Engineering Research Center, Report CERC-08--010, 95 p.
- LSTC (2017) LS-Dyna User's Manual. Livermore Software Technology Corporation, Livermore California.
- Puebla, H., Byrne, P.M., and Phillips, R. (1997). Analysis of CANLEX Liquefaction Embankments: Prototype and Centrifuge Models. *Canadian Geotechnical Journal*, 34(5), 641-657.
- Šmilauer, V. et al. (2015) Using and Programming in Yade Documentation. 2nd ed. The Yade Project. DOI: 10.5281/zenodo.34043.
- Tannu, N.S. (2017) A discrete element approach to predicting the uniaxial compressive response of plain concrete. MS thesis. UNC Charlotte.
- Vecchio, F.J., and Collins, M.P. (1993). Compression response of cracked reinforced concrete. *Journal of Structural Engineering*, 119(12), 3590-3610.

# Numerical Investigation of Earthquake Rupture and Off-Fault Fracture Response with a Coupled Discrete-Continuum environment

Sacha Emam<sup>1</sup>, Caroline Darcel<sup>1</sup>, Manh Huy Tran<sup>1</sup>, Johannes Suikkanen<sup>2</sup>

<sup>1</sup> Itasca Consultants S.A.S., 69130, Écully, France

<sup>2</sup> Posiva Oy, FI-27160, Eurajoki, Finland  
s.emam@itasca.fr

**Keywords:** distinct-element method; finite-difference method; earthquake rupture

Conservative estimates of seismically induced secondary fracture shear displacements are crucial to assess long-term safety of nuclear waste deep repositories.

The Distinct Element Method is a simulation method well suited to the investigation of rock mass behavior via the Synthetic Rock Mass approach (Mas Ivars et. al., 2011). Intact rock is modeled using a bonded-particle approach, and discontinuities are inserted using contact constitutive models able to represent smooth interfaces. This representation incorporates key mechanisms at the micro-scale, including bond breakage and large displacements, and reproduces observed emergent behavior at the macroscopic scale. Being computationally intensive, the drawback of this method lies in its inability to address boundary-value problems, for which continuum or coupled discrete-continuum approaches are generally required.

The work presented uses a three-dimensional coupled discrete-continuum environment to simulate the boundary-value problem (Li et. al., 2015). The inner region is modeled using the distinct element software PFC3D. The outer region is modeled using the finite-difference software FLAC3D. The discrete and continuum regions overlap. In the overlapping region, particle displacements in the discrete model are required to conform to the continuum displacements at the corresponding particle positions using a linear interpolation function, and the continuum grid-point velocities are corrected using averages of the discrete model velocities over a wavelength that is consistent with the zones size. This approach prevents spurious mechanical wave reflection at the discrete-continuum interface by filtering high-frequency components, and is therefore well suited for the investigation of the mechanical response of rock masses subject to dynamic solicitations.

The presentation describes the coupled environment and validation tests, and then the application of the environment to simulate a boundary value problem is discussed. The boundary value problem investigates the case of a rupture along a shallow, gently dipping deformation zone. A controlled earthquake rupture is input on a primary fault, and temporal evolution of the shear displacements along the primary fault and secondary fractures are monitored.

## References

- Li M., Yu H., Wang J., Xia X. and Chen, J. (2015). A multiscale coupling approach between discrete element method and finite difference method for dynamic analysis, *International Journal for Numerical Methods in Engineering* 102, 1–21.
- Mas Ivars D., Pierce M.E., Darcel C., Reyes-Montes J., Potyondy D.O., Paul Young R., and Cundall P.A. (2011) The synthetic rock mass approach for jointed rock mass modelling, *International Journal of Rock Mechanics and Mining Sciences* 48, 219–244.

## Assessing the hydromechanical properties along a listric fault, using DEM modelling

Veronica Girardi<sup>1</sup>, Frédéric Victor Donzé<sup>2</sup>, Paolo Simonini<sup>1</sup>

<sup>1</sup> DICEA – University of Padua, via Ognissanti 39, 35129 Padua, Italy

<sup>2</sup> ISTERre – Université Grenoble Alpes, CNRS, 38000 Grenoble, France  
Veronica.girardi.1@studenti.unipd.it

**Keywords:** fault modelling; hydromechanical properties; permeability

Listric faults are curved normal faults, with a surface concavity upward and dip angle decreasing with the depth. This bending trend depends on a combination of crossed layers' mechanical properties, but also on the values and orientation of the maximum principal stress acting. Tectonic extensional regimes along passive margins, where sedimentation and subsidence are common dominant phenomena, are the typical location for listric fault's onset and development. Plastic deformations progressively accumulates in the hanging-wall above the fault, till the emergence of growth fault secondary systems, synthetic or antithetic. These faults often bound well-defined rock blocks which rotate generating typical rollover anticlines. These complex geological features around major listric faults, are believed to represent optimal hydrocarbon sites. Therefore, it's fundamental to explore the coupling of mechanical and hydraulic processes acting at different scales in these natural systems.

Among them the abnormal pore pressure values, frequently higher than the hydrostatic pressures, traditionally employed as marker for HC presence at high depths, are one of the major cause of fluid mobilization in sedimentary basins crossed by faults. These pressure could become even too high to undermine the seal integrity, over the reservoirs. These complex hydromechanical aspects are object of conceptual geomechanical models aiming to assess the maximum overpressures in petroleum systems, to constrain the height of HC columns, like the “dynamic capacity model” (T. Finkenberget al., 2011). The present study focuses on the diving mechanisms involved in fluid migration: hydraulic fracturing, when reservoir pore pressure is equal to the minimum principal stress in the seal, and leakage through fault reactivation, when reservoir pore pressure is equal to a critical pressure generating shear.

A simple model of a stratified system crossed by a listric fault was realized with a CAD software, Rhinoceros, in order to reproduce a real representative cross section, later extruded in the third direction. The listric fault separates a hanging-wall with a pre-existent deformation, from an initially undeformed footwall. An automatic mesh converter tool, “Griddle”, was used to obtain a discontinuous medium mesh, consisting in several tetrahedral shape blocks, ready to be exported in a DEM software for hydromechanical simulations: 3DEC by Itasca.

3DEC software based on the distinct element method, has been used to model 3D discontinuous systems. This method is characterized by a “soft” contact approach and an explicit scheme to solve the equation of motion of each discrete element. For the model built in this study, it was assumed an elastic linear isotropic behaviour for the blocks, localizing failure only along the joints whose behaviour is governed by two linear laws; one for the limitation of the maximum traction force, considering the joint tensile strength, and the other one for the maximum shear force, a Coulomb slip law, taking in account friction and cohesion along the joint.

Concerning the hydromechanical analysis, Terzaghi's effective stress principle is used to calculate both the states of stress in the blocks and along the discontinuities. The flow formulation is only along the discontinuities, the “joint fluid flow”, based on the parallel plate model for laminar flow, with roughness homogenized along a REA (Representative Elementary Area). It includes a cubic dependence of the specific discharge on the hydraulic aperture, which in turn depends on the mechanical aperture, variable in a prefixed range during the simulations.

In 3DEC, after the geometry definition and the material properties assignment, a series of “one-way” coupled simulations were set: a first computational cycle only mechanic, to stabilize the model under gravity loading, followed by a purely hydraulic cycle, and the last one again mechanical, to evaluate the states superpositions.

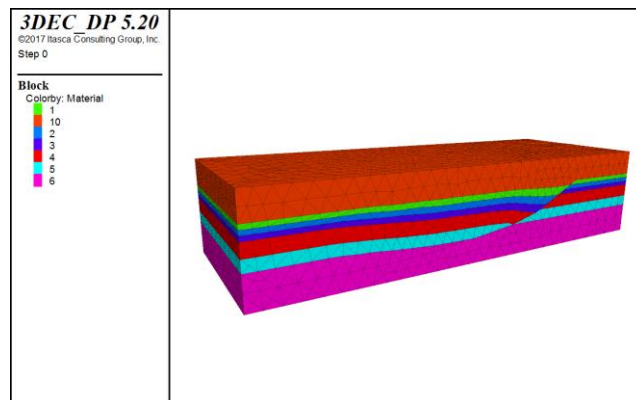

**Figure 1** Model of the stratified system crossed by a major listric fault.

The first natural process simulated was the migration of fluid from a low source rock till a shallower permeable layer. Thus, after the installation of a hydrostatic gradient of pore pressure, an overpressure was applied along the model base, and the flow paths were evaluated, as a consequence of changes in permeability of the layers and of the fault. Afterwards, an hydrofracturing process and fault reactivation were evaluated, after an over-pressurization of the reservoir layer localized in an intermediate position of the model.

## References

- Anowai C., Onuoha K.M., Opara A.I. et al. (2012) Geopressure and Trap Integrity Predictions from 3- D Seismic Data: Case Study of the Greater Ughelli Depobelt, Niger Delta, *Oil & Gas Science and Technology - Rev. IFP Energies nouvelles*, Vol. 68.
- Brun J.P., Mauduit T. (1998) Growth fault/rollover systems' birth, growth, and decay, *Journal of geophysical research*, 103(B8): 18,119–18,136.
- Finkenberg T., Flemings P., Stump B., Zoback M. (2001) Stress, pore pressure, and dynamically constrained hydrocarbon columns in the South Eugene Island 330 field, northern Gulf of Mexico, *AAPG Bulletin*, 85 (6): 1007:1031.
- Graulds D. (1999) Overpressures: causal mechanisms, conventional and hydromechanical approaches, *Oil & Gas Science and Technology - Rev. IFP Energies nouvelles*, Vol. 54.
- Gregg Erickson S., Strayer L. M., Suppe J. (2001) Mechanics of extension and inversion in the hanging walls of listric normal faults, *Journal of geophysical research*, 106 (B11): 26,655–26,670.
- Nauroy Jean-F. (2011) Geomechanics applied to the petroleum industry, IFP Energies Nouvelles Publications.
- Osborne M.J., Swarbrick R.E. (1997) Mechanisms for Generating Overpressure in Sedimentary Basins: A Reevaluation, *AAPG Bulletin*, 81(6): 1023-1041.
- Papazoglou A. (2015). Basin-scale fault architecture study based on DEM modelling, GCER master thesis.
- Singh M., Kumar A., Samadhiya N.K. et al. (2015). A nonlinear criterion for triaxial strength of inherently anisotropic rocks, *Rock Mech Rock Eng.*, 48: 1837-1405.

## Acknowledgements

The authors acknowledge Total S.A. for the project funding and special thanks go to Claude Gout for his support and expert advice.

## A Bayesian calibration toolbox for YADE

Hongyang Cheng<sup>1</sup>, Takayuki Shuku<sup>2</sup>, Klaus Thoeni<sup>3</sup>, Pamela Tempone<sup>4</sup>, Stefan Luding<sup>1</sup>, Vanessa Magnanimo<sup>1</sup>

<sup>1</sup>Multi Scale Mechanics (MSM), Faculty of Engineering Technology, MESA+, University of Twente, P.O. Box 217, 7500 AE Enschede, The Netherlands

<sup>2</sup> Graduate School of Environmental and Life Science, Okayama University, 3-1-1 Tsushima naka, Kita-ku, Okayama 700-8530, Japan

<sup>3</sup> Centre for Geotechnical and Materials Modelling, The University of Newcastle, Callaghan, NSW 2308, Australia

<sup>4</sup> Division of Exploration and Production, Eni SpA, Milano, Lombardy, Italy  
h.cheng@utwente.nl

**Keywords:** Iterative parameter estimation; Sequential Monte Carlo; Uncertainty quantification; Discrete element method; X-ray tomography

The nonlinear history-dependent macroscopic behavior of geomaterials is rooted in the micromechanics at contacts and the irreversible rearrangement of the microstructure. The discrete element method (DEM) can predict the micromechanics using contact laws (Cundall & Strack, 1979), but the prior knowledge about contact laws and micromechanical parameters is generally unknown because of the diversity of granular materials (Cheng et al., 2018). We propose an iterative Bayesian filtering framework to infer the posterior distribution of micromechanical parameters and update the posterior probabilities conditioned to time-dependent experimental data. Data-driven Bayesian calibration is conducted for the DEM simulation of glass beads under oedometric compression, using the a priori particle configuration obtained from 3D X-ray computed tomography images. The posterior means of the respective micromechanical parameters converge within three iterations (Fig. 1), leading to excellent agreement between the experimental results and the numerical predictions given by the optimal parameter sets and the ensemble (Fig. 2).

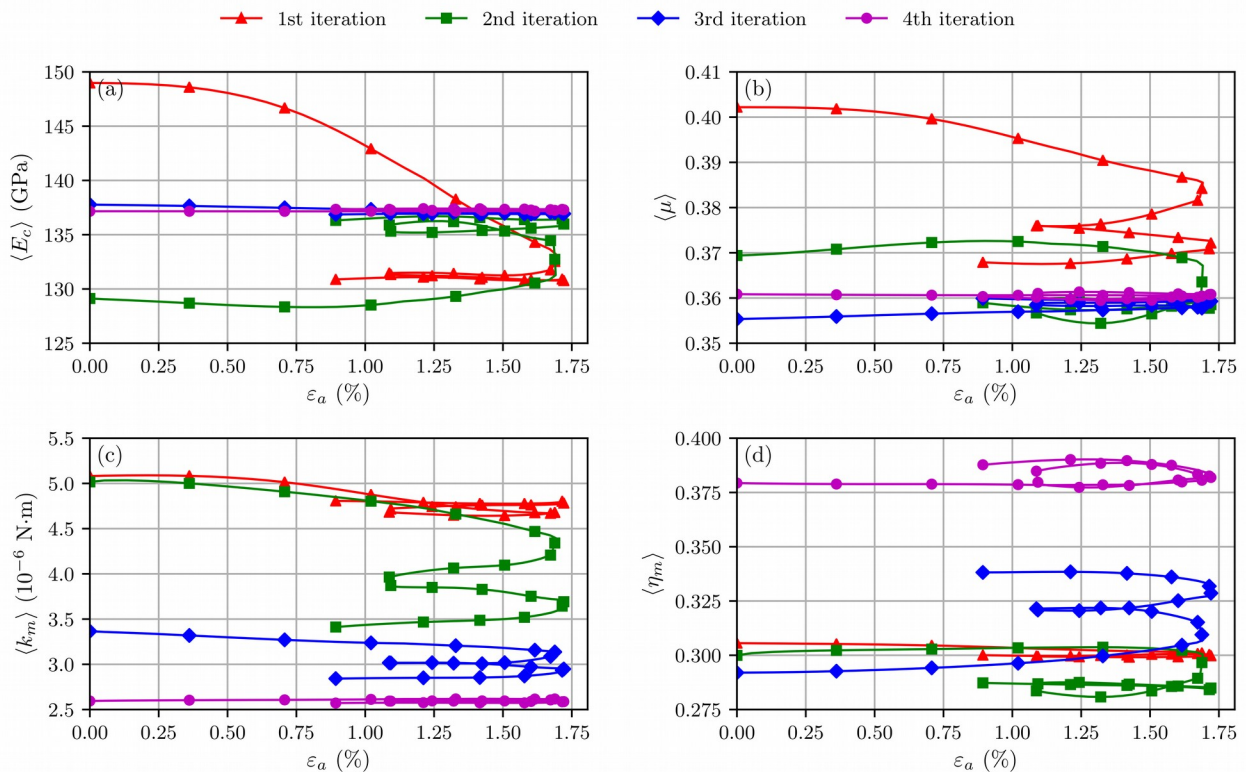

**Figure 1** Evolution of identified values for Young's modulus  $E_c$ , friction angle  $\mu$ , rolling stiffness  $k_m$  and friction  $\eta_m$  over axial strain during each iteration.



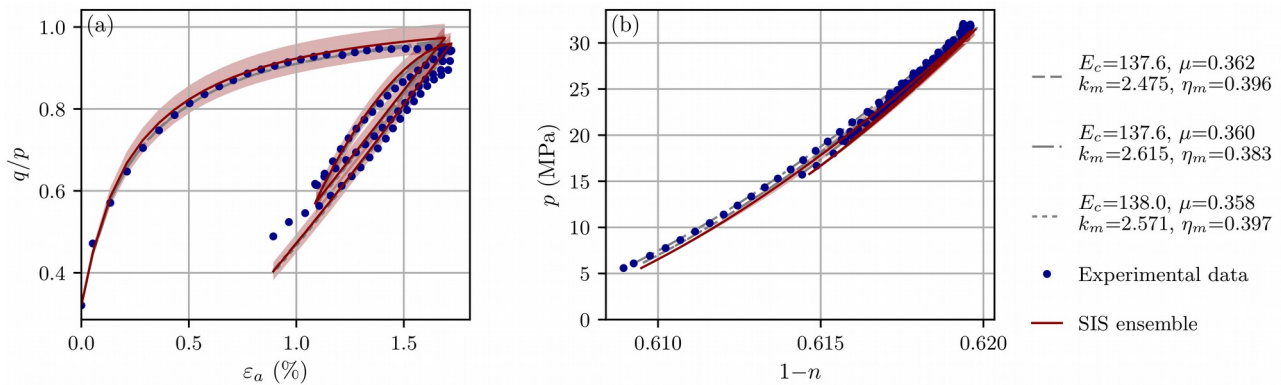

**Figure 2** Comparison of experimental data and numerical predictions at the third iteration. Gray lines represent predictions given by the top three most probable parameter sets. Dark red line indicates the ensemble averages of the sequential importance sampling (SIS) samples. The shaded area shows the uncertainties

The proposed calibration method is fast, efficient and automated. It iteratively uses the previous posterior as the new proposal distribution and limits the simulations to the one within highly probable parameter subspaces. The Bayesian calibration provides a better understanding of micro-macro uncertainty propagation, from the posterior distribution over the micromechanical parameters and macroscopic quantities of interest, conditioned to the experimental stress-strain relationship of the glass bead specimen. The present work shows that the iterative Bayesian filtering framework has a great potential for uncertainty quantification and propagation in multiscale characterization and simulations of granular materials.

## References

- Cundall P.A. and Strack O. D. L. (1979) A discrete numerical model for granular assemblies, *Géotechnique* 29:1, 47–65
- Cheng, H., Shuku, T., Thoeni, K. and Yamamoto, H. (2018) Probabilistic calibration of discrete element simulations using the sequential quasi-Monte Carlo filter, *Granular Matter* 20 (1), 11

## Acknowledgements

This work was financially supported by Eni S.p.A.

# A direct calibration method for cohesive beam bond models

Damien André<sup>1</sup>, Truong Thi Nguyen<sup>1</sup>, Marc Huger<sup>1</sup>

<sup>1</sup> Univ. Limoges, IRCER, UMR 7315, F-87000 Limoges, France

damien.andre@unilim.fr

**Keywords:** calibration; continuum; cohesive beam; fracture

Discrete Element Method (DEM) could be an interesting approach to study multi-damaged materials because it takes naturally into account discontinuities. The discrete element approach used here is a mix between lattice models and particle bond models as it was first proposed by Potyondy & Cundall (2004). In order to simulate brittle elastic media such as rocks, glasses or ceramics, discrete elements are bonded by “cohesive beams”. In such model, the discrete elements are bonded by Euler-Bernoulli beams that can be loaded in a tensile, a bending and a torsion mode. For details see André et al. (2012). The given whole assembly leads to an emergent behavior that mimics a brittle elastic media characterized by Young’s modulus, Poisson’s ratio and failure strength.

The great advantage of this method, in comparison with continuous approaches, is the introduction of local failure criterion. If this criterion is reached during a simulation, some bonds are removed from the model in order to simulate crack propagations and coalescences. In the proposed study, the failure criterion is based on the computation of local Cauchy stress tensors as described in André et al. (2013). Based on the Rankine’s criterion well adapted to the fracture of brittle solids, bonds are removed if maximal principal stresses computed from these Cauchy stress tensors reach a given value.

The main difficulty of this approach is to tackle quantitative simulations. Local parameter values must be correctly chosen in order to simulate quantitatively at the assembly scale the right tensile strength. By consequence, calibration steps of such models is very important to reach quantitative results. These steps are generally fastidious because they involve many computations and analyses. In some cases, this task must be restart from zero if the geometry and/or the configuration of the initial domain changes. This is a huge limitation that prevents the dissemination of this original and interesting method.

The study presented here proposes to tackle this difficulty. Simple mathematical functions were deduced from more than 5,000 DEM computations. So, relations between local parameters, that needs to be calibrated, and global parameters, that are generally known, are described though analytical functions. This approach allows for users to simplify the computational pre-processing of brittle elastic material because they are able to enter directly the values of Young’s modulus, Poisson’s ratio and failure strength in the DEM code without any fastidious calibration steps.

## References

- Potyondy, D. & Cundall, P. A. (2004), A bonded-particle model for rock, *International Journal of Rock Mechanics and Mining Sciences* 41(8), 1329–1364. Rock Mechanics Results from the Underground Research Laboratory, Canada.
- André, D., Iordanoff, I., luc Charles, J. & Néauport, J. (2012), Discrete element method to simulate continuous material by using the cohesive beam model, *Computer Methods in Applied Mechanics and Engineering* 213216(0), 113–125.
- André, D., Jebahi, M., Iordanoff, I., luc Charles, J. & Nauport, J. (2013), Using the discrete element method to simulate brittle fracture in the indentation of a silica glass with a blunt indenter, *Computer Methods in Applied Mechanics and Engineering* 265(0), 136 – 147.

## Genetic programming applied to DEM calibration

Marcelo De Simone, Marcos G. Filho, Lourdes M. S. Souza, Fernanda L.G. Pereira, Deane Roehl  
 Tecgraf Institute and Department of Civil Engineering, Pontifical Catholic University, Marquês de  
 São Vicente 225, Gávea, RJ, 22451-900, Rio de Janeiro, Brazil  
 msampaio@tecgraf.puc-rio.br

**Keywords:** Discrete Element Method; Genetic Programming; Calibration; Uniaxial Compressive Test.

The use of the discrete element method (DEM) has risen lately in the field of geomechanics. DEM applications aim mainly at understanding rock and soil behaviour at the grain scale. DEM models can be quite different regarding model initialization, model structure (clumps) or particle shapes. Each of these features can affect the results of the analyses. Besides that, the microparameters must be carefully chosen in order to simulate a specific rock. This work focuses on this calibration process, which relates the microparameters with the macroproperties of the material.

Different calibration techniques are used when modelling with DEM. The most used method is the trial and error, in which several models with different parameter values are analysed seeking the best fit to laboratory tests. This is very time consuming because it is necessary to run a great number of models until agreement is reached. Another approach is presented by Koolivand-Salooki et al. (2017), who use the Genetic Programming (GP) model in order to get the Uniaxial Compressive Strength (UCS) from formation porosity, bulk density and water saturation.

GP is based on natural genetic operations (crossover, mutation and reproduction), following the Darwinian principle of reproduction and survival. The nodes in the GP tree structure are divided into two groups: terminal (constants and variables) and function (arithmetic operations). These two groups are used in order to form expression trees, giving the solution to a problem. According to the authors, this method needs fewer data than other artificial intelligence methods. In this work, the GP is used to calibrate the microparameters from the Jointed Cohesive Frictional (JCF) bonded contact model, described by Scholtès & Donzé (2013). The equations for this bonded contact model are presented in Eq. (1) and Eq.(2) for the normal force ( $F_n$ ) and maximum admissible normal force ( $F_{n,max}$ ). In Eq. (3) and Eq. (4) the shear force ( $F_s$ ), which is evaluated in an incremental manner, and the maximum admissible shear force ( $F_{s,max}$ ) are presented.

$$F_n = k_n \cdot \Delta D \quad (1)$$

$$F_{n,max} = -t \cdot A_{int} \quad (2)$$

Here,  $k_n$  is the contact normal stiffness,  $\Delta D$  is the overlap between the particles (positive) or the distance between them (negative),  $t$  is the tensile strength and  $A_{int}$  is the interacting surface between the particles.

$$F_s = \{F_s\}_{updated} + k_s \cdot \Delta U_s \quad (3)$$

$$F_{s,max} = F_n \cdot \tan(\phi) + c \cdot A_{int} \quad (4)$$

In addition,  $k_s$  is the shear stiffness,  $\Delta U_s$  is relative incremental tangential displacement,  $\phi$  is the frictional angle and  $c$  is the cohesion of the contact between two particles.

Figure 1 presents the DEM model of the rock sample. It consists of 1,204 particles, with radius of 2 mm in a cylinder with diameter of 37 mm and height of 65 mm.

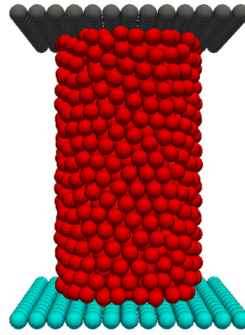

**Figure 1** Rock sample used for the uniaxial compressive test.

The objective of the GP procedure is to use the numerical model to find the same UCS and Young's Modulus ( $E$ ) from the laboratory test. Therefore, one hundred models were carried out using an in house DEM software in order to train and test the GP. Hence, the result is a function relating the five microparameters ( $k_n$ ,  $k_s$ ,  $\phi$ ,  $c$  and  $t$ ) with the UCS and another function relating these microparameters with  $E$ .

The following step is to perform an optimization procedure, similar to the one presented by Yoon (2007), using the commercial software, Matlab. Knowing rock UCS and  $E$ , this procedure enables finding the values for the five microparameters. A brief result from this group of models is presented in Table 1. After having the results, nine new tests are carried out using GP equations and the in house DEM solver in order to validate this procedure. The results are presented in Table 1.

**Table 1** Results from the models run for the GP and the validation models.

Number of Models	Objective	Max E error (%)	Max UCS error (%)	Mean E error (%)	Mean UCS error (%)
80	Training	5.63	9.75	1.00	2.31
20	Test	6.38	7.75	1.33	2.81
9	Validation	1.82	5.77	0.79	2.85

The results obtained in this work show good agreement between the values of UCS and Young's Modulus from the GP equations and those obtained numerically with the DEM solver.

## References

- Koolivand-Salooki, M., M. Esfandyari, E. Rabbani, M. Koulivand, and A. Azarmehr. 2017. "Application of Genetic Programming Technique for Predicting Uniaxial Compressive Strength Using Reservoir Formation Properties." *Journal of Petroleum Science and Engineering* 159(April):35–48.
- Scholtès, Luc and Frédéric-Victor Donzé. 2013. "A DEM Model for Soft and Hard Rocks: Role of Grain Interlocking on Strength." *Journal of the Mechanics and Physics of Solids* 61:352–69.
- Yoon, Jeoungseok. 2007. "Application of Experimental Design and Optimization to PFC Model Calibration in Uniaxial Compression Simulation." *International Journal of Rock Mechanics and Mining Sciences* 44(6):871–89.

## Acknowledgements

The authors gratefully acknowledge support from Shell Brasil through the "Coupled Geomechanics" project at TecGraf Institute (PUC-Rio) and the strategic importance of the support given by ANP through the R&D levy regulation.

# Timing comparison between two different approaches for wire mesh modelling

Antonio Pol<sup>1</sup>, Fabio Gabrieli<sup>1</sup>, Klaus Thoeni<sup>2</sup>

<sup>1</sup> Dept. ICEA, University of Padova, 35129, Padova, Italy

<sup>2</sup> Centre for Geotechnical Science and Engineering, University of Newcastle, Callaghan, NSW 2308, Australia  
antonio.pol@phd.unipd.it

**Keywords:** Wire mesh; GridConnection; Computational cost;

This work deals with a comparison between two different numerical discrete element approaches for modelling a double-twisted hexagonal wire mesh: a node-wire-based (NWB) and a cylinder-wire-based (CWB) approach. In the former each wire is schematized with a remote interaction between two nodes without a physical shape (Nicot et al., 2001, Thoeni et al., 2014), whereas in the latter cylindrical elements are used to represent the wires (Effeindzourou et al., 2016, Albaba et al., 2017). A single hexagonal mesh element, for both the approaches, is presented in Figure 1a for clarity.

In the NWB approach the density of the node is artificially increased in order to keep the total mass of the mesh panel constant. Moreover, the particle radius is fixed equal to 4 times the single wire diameter (4x2.7 mm) for arbitrary convention. In the second approach the cylinders have the same diameter of the single wires and their density is equal to the real one. In both approaches the interaction between the nodes, which is possible only in tensile direction, is represented by a piecewise force-displacement curve derived from a laboratory tensile test on a wire; two different curves are used to represent the single and the double-twisted wire. The mechanical response of the numerical mesh has been compared with experimental results (tensile and punch tests) showing a good agreement (Gabrieli et al., 2017).

Two cases are studied: one where the mesh interacts with a limited number of external bodies and one other with a considerable number of bodies. In the first case a 3x3 m<sup>2</sup> mesh panel interacts with a punching element made of several triangular elements which are moved against the mesh with a constant velocity, whereas in the second case a 2.88x9 m<sup>2</sup> mesh panel is loaded by a column of sphere under gravity (mesh-soil test). In the latter case the force and the displacement are monitored in the center of the panel. In the aforementioned cases the two approaches are compared with regards to the mechanical response of the wire mesh and the computational cost of the simulation.

The mechanical response of the two approaches, in the different conditions of testing, is shown in Figure 1. The curves are normalized with respect to the maximum value of force and displacement at the failure obtained with the node-wire-based approach for the considered test.

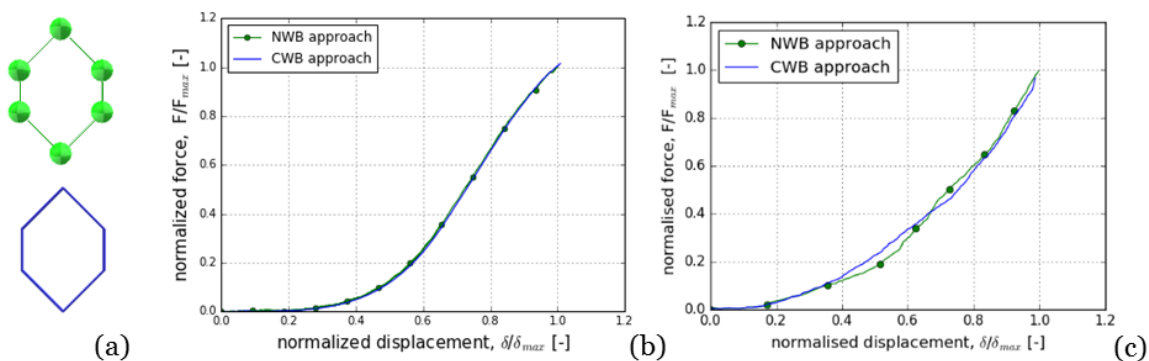

**Figure 1** (a) Example of a periodic hexagon of the wire mesh: NWB (green), CWB (blue). Numerical response of the mesh: (b) punch test, (c) mesh-soil test.

It is clear that the mechanical response of the mesh is approximately the same for both approaches, as the same tensile law is used in both cases. However, small discrepancies between the two approaches are visible in Figure 1c which are probably ascribable to some differences in the positions and directions of contacts between the mesh and the deformable soil column.

The computational cost of the two approaches with reference to the different phases of the DEM algorithm and a comparison of the ratio of the computational time to the total number of bodies are reported in Figure 2. In all the simulation the time step is fixed and equal to  $1.3 \times 10^{-6}$  s and the time statistics refer to a fixed number of steps (150000 for the punch test, 100000 for the mesh-soil test).

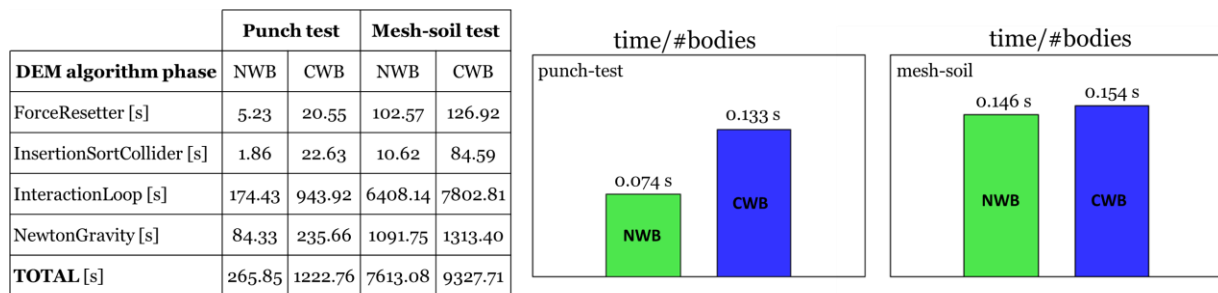

**Figure 2** Comparison of the computational time for the different approaches (NWB and CWB) in the two test conditions.

As a first result it is interesting to note that the total time required with the cylinder-wire-based approach is equal to 4.5 times, for the punch test, and 1.2 times, for the mesh-soil test, the one required with the node-wire-based approach. Focusing on the ratio of the total time to the number of bodies, the computational time required by the CWB (#bodies = 9197), for the punch test is approximately equal to 2 times the one required by the NWB (#bodies = 3584). For the mesh-soil test the two times are approximately the same for the two approach: CWB (#bodies = 64252), NWB (#bodies = 52063). Therefore, the higher computational demand required by the CWB approach is mainly controlled by the higher number of elements.

Moreover, in the CWB there is also a costlier contact detection phase (InsertionSortCollider) which is independent of the number of bodies; however, its influence on the total time of the simulation is very low.

Concluding, both the approaches are approximately equivalent in terms of mechanical response when the mesh interacts with large bodies, whereas some discrepancies are visible when the contact with smaller bodies has to be handled. Nevertheless, the CWB appears more suited to deal with angular particles and with other external elements.

This simple timing comparison between the two approaches shows that the computational cost is mainly influenced by the number of bodies, therefore when the number of external bodies (i.e. facets, blocks or soil particles) is considerably larger than the one of the elements of the mesh (i.e. nodes or cylinders) the computational effort required by the two approaches becomes comparable.

## References

- Albaba, A. et al. (2017). DEM modeling of a flexible barrier impacted by a dry granular flow, *Rock Mechanics and Rock Engineering* 50:11, 3029-3048
- Effeindzourou, A. et al (2016). Modelling of deformable structures in the general framework of the discrete element method, *Geotextiles and Geomembranes* 44(2): 143-156
- Gabrieli, F. et al. (2017). Comparison of two DEM strategies for modelling cortical meshes, *V International Conference on Particle-based Methods – Fundamentals and Applications, Particles 2017*: 489-496.
- Nicot, F. et al. 2001. Design of rockfall restraining nets from a discrete element modelling, *Rock Mechanics and Rock Engineering* 34: 99-118
- Thoeni K., et al. (2014). A 3D discrete element modelling approach for rockfall analysis with drapery systems, *International Journal of Rock Mechanics and Mining Sciences* 68: 107-119.

# Building a high performing GPU accelerated Yade PFV computer at low cost

Robert Caulk<sup>1</sup>

<sup>1</sup> University of California, San Diego, 92122, La Jolla, California  
 rcaulk@eng.ucsd.edu

**Keywords:** GPU acceleration; Pore Finite Volume; computer build; price performance

This presentation demonstrates the feasibility of building a low cost, high-performing GPU-accelerated Yade computer for running coupled DEM-Pore Finite Volume simulations. First, we focus on the part selection. Luckily, Yade does not necessarily need the biggest and most powerful processor, Yade does not need an inordinate amount of ultra-fast RAM, and Yade does not require a brand new video game dream GPU. In fact, used 12-core server processors can be purchased for under 100 USD, 16 GB RAM stick prices have dropped significantly over the past few years, and a six year old Tesla GPU has four times the double precision computing power as brand new gaming cards at 1/5 of the price. This talk hopes to show how a typical Yade user could naively spend an extraordinary amount of money on an over built (and incorrectly built) workstation, simply to find out their simulations run at the same speed as if they had purchased a well configured laptop. We show some benchmarks demonstrating the efficiency of GPU acceleration in comparison to CPU based computing (Figure 1). Finally, we discuss the uses cases, strengths, and weaknesses of GPU acceleration.

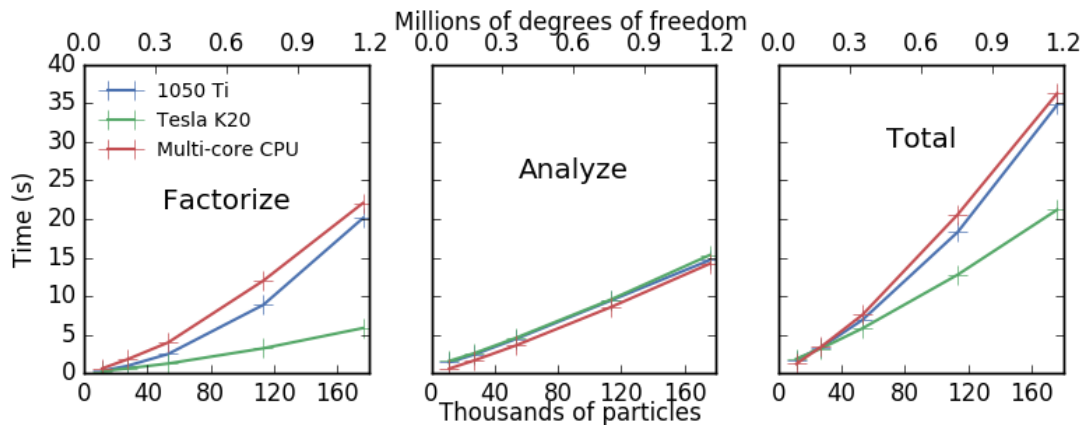

**Figure 1** Factorization and analyze times for PFV matrices using GPUs and 10-core CPUs





## Organizing Committee

- Chairman: Jérôme Duriez (IRSTEA)
- Stéphane Bonelli (IRSTEA)
- Christophe Bouillon (IRSTEA)
- Dominique Breil (IRSTEA)
- Naim Chaouch (IRSTEA)
- Vincent Garnier (Aix-Marseille University)
- Olivier Millet (La Rochelle University)
- François Nicot (IRSTEA)
- Laurent Peyras (IRSTEA)
- Pierre Philippe (IRSTEA)

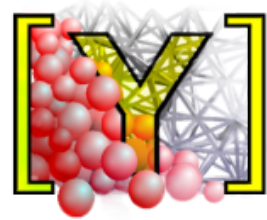

ISBN 979-10-94074-06-0

