



**HAL**  
open science

## Modelling the absorption of a gas mixture in a cross-flow hollow-fiber membrane module

Valentin Fougerit, Julien Lemaire, Marc-André Theoleyre, Moncef Stambouli

### ► To cite this version:

Valentin Fougerit, Julien Lemaire, Marc-André Theoleyre, Moncef Stambouli. Modelling the absorption of a gas mixture in a cross-flow hollow-fiber membrane module. 13th International Conference on Gas-Liquid and Gas-Liquid-Solid Reactor Engineering, Aug 2017, Brussels, Belgium. hal-01816508

**HAL Id: hal-01816508**

**<https://hal.science/hal-01816508v1>**

Submitted on 15 Jun 2018

**HAL** is a multi-disciplinary open access archive for the deposit and dissemination of scientific research documents, whether they are published or not. The documents may come from teaching and research institutions in France or abroad, or from public or private research centers.

L'archive ouverte pluridisciplinaire **HAL**, est destinée au dépôt et à la diffusion de documents scientifiques de niveau recherche, publiés ou non, émanant des établissements d'enseignement et de recherche français ou étrangers, des laboratoires publics ou privés.

# Modeling the absorption of a gas mixture in a cross-flow hollow-fiber membrane module

FOUGERIT Valentin, LEMAIRE Julien, THEOLEYRE Marc-André, STAMBOULI Moncef

Laboratoire Génie des Procédés et Matériaux, CentraleSupélec, Université Paris-Saclay, SFR Condorcet FR  
CNRS 3417, Centre Européen de Biotechnologie et de Bioéconomie (CEBB),  
chemin des Sohettes F-51110 Pomacle, FRANCE.

## Introduction

Among the industrial processes involving gas-liquid exchanges, hollow-fiber membrane module (HFMM) is an efficient technology thanks to their higher specific area per volume compared to packed columns. Furthermore, it avoids operational problems such as flooding, foaming or plugging.

To help the development of HFMM at an industrial scale, models need to be developed to understand and predict mass transfers. Several studies have described the gas-liquid mass transfer occurring in a hydrophobic gas-liquid HFMM. As carbon capture is a large application of HFMM, most of them have focused on CO<sub>2</sub> absorption as a pure gas (Mavroudi et al., 2006; Boributh et al., 2011) or mixed in an inert flow (Lu et al., 2008; Al-Marzouqi et al., 2008; Khaisri et al., 2010; Goyal et al., 2015) under atmospheric pressure. To assess the efficiency of a biogas upgrading process, the CH<sub>4</sub> losses due to its absorption in the solvent is a key-point. Therefore, an absorption model for a multi-components gas mixture under pressure (0-5 bar g) was developed to identify possible thermodynamic interactions or transfer limitations. The total transfer coefficient  $K_{tot}$  is based on the resistance-in-series model:

$$\frac{1}{K_{tot} d_{fo}} = \frac{1}{k_l d_{fo}} + \frac{k_H^{cc}}{k_m d_{in}} + \frac{k_H^{cc}}{k_g d_{fi}}$$

$k_l$ ,  $k_m$  and  $k_g$  are the respective mass transfer coefficients for liquid, membrane and gas phases.

$k_{H,i}^{cc} = \frac{c_i^{aq}}{c_i^g}$  is the adimensional Henry coefficient.  $d_{fo}$ ,  $d_{fi}$  and  $d_{in}$  are respectively the outer, inner and logarithmic mean diameters of the hollow-fiber.

Previous models described counter-current flow modules. However, industrial HFMM may include a baffle to divert the liquid flow and increase mass transfer efficiency. Then, for this geometry, the liquid hydrodynamic in the shellside is best described by a cross-flow model.

Moreover, mass transfer in membrane contactor is limited by pore wetting. After some hours of operation, mass-transfer resistance increases (Mavroudi et al., 2006). Wetting was described by liquid condensation in the largest pores of the membrane (Lu et al., 2008; Goyal et al., 2015). As it is a limiting factor for gas absorption efficiency, the model must be validated to ensure process up-scaling.

The present work aims at developing a predictive gas-liquid mass-transfer model for a binary gas mixture which integrates the liquid flow pattern (cross-flow). This model can be extended to a multi-components gas mixture. The second objective is to implement and experimentally validate a model for the membrane wetting phenomenon under varying working pressures. In the end, model predictions will be compared to experimental data from a biogas upgrading process.

## Materials and methods

Figure 1 presents the pilot equipment used to run the experiments for optimizing model parameters and validating the membrane wetting model. The mixture of inlet gas (CO<sub>2</sub>/CH<sub>4</sub>) was adjusted (100-

700 NI/h) and the outlet gas flow was measured with mass flow controllers (Bronkhorst). Gas analysis was performed at the inlet and outlet of the membrane contactor with a micro gas chromatography (Agilent 490) with two columns. Softened water was used as the solvent. The liquid flow on the shellside (1-3.5 L/min) was regulated by a vortex flowmeter (Liqui-View) and pressure was controlled at the inlet and the outlet of the membrane contactor (3-5.5 bar g). The CO<sub>2</sub> and CH<sub>4</sub> absorption flowrates were calculated by mass balance. HFMM was Membrana Liqui-Cel Extra-Flow 2.5x8 equipped with X-50 fibers.

Figure 1: Experimental set-up

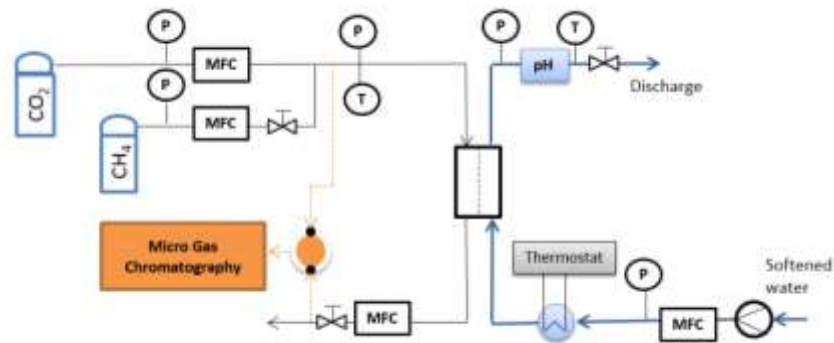

Up to now, tests using CO<sub>2</sub> as a pure gas were performed. Results in the non-wetting mode were used to optimize parameters from the Chilton-Colburn analogy to calculate liquid mass-transfer coefficient. In the dry mode, concentration profiles can be displayed for a binary gas mixture (Figure 2).

Figure 2: CO<sub>2</sub> concentration profiles in the gas and the liquid phase

Inlet gas 60 % CH<sub>4</sub> + 40 % CO<sub>2</sub>, P<sub>gas</sub> = 5 bar g, Q<sub>gas</sub> = 500 NI/h, Q<sub>liq</sub> = 1 L/min

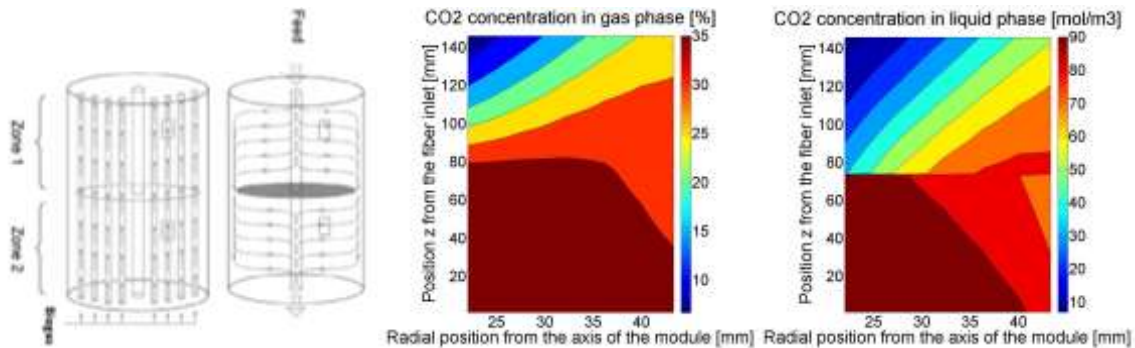

Next, the results in the wetting mode will validate the model for membrane wetting.

Tests at different inlet compositions and operating parameters will be performed for further validation with a binary gas mixture.

## References

- Al-Marzouqi, M.H., El-Naas, M.H., Marzouk, S.A.M., Al-Zarooni, M.A., Abdullatif, N., and Faiz, R. (2008). Modeling of absorption of CO<sub>2</sub> in membrane contactors. *Sep. Purif. Technol.* 59, 286–293.
- Boributh, S., Assabumrungrat, S., Laosiripojana, N., and Jiratananon, R. (2011). A modeling study on the effects of membrane characteristics and operating parameters on physical absorption of CO<sub>2</sub> by hollow fiber membrane contactor. *J. Membr. Sci.* 380, 21–33.
- Goyal, N., Suman, S., and Gupta, S.K. (2015). Mathematical modeling of CO<sub>2</sub> separation from gaseous-mixture using a Hollow-Fiber Membrane Module: Physical mechanism and influence of partial-wetting. *J. Membr. Sci.* 474, 64–82.
- Khaisri, S., deMontigny, D., Tontiwachwuthikul, P., and Jiratananon, R. (2010). A mathematical model for gas absorption membrane contactors that studies the effect of partially wetted membranes. *J. Membr. Sci.* 347, 228–239.
- Lu, J.-G., Zheng, Y.-F., and Cheng, M.-D. (2008). Wetting mechanism in mass transfer process of hydrophobic membrane gas absorption. *J. Membr. Sci.* 308, 180–190.
- Mavroudi, M., Kaldis, S.P., and Sakellariopoulos, G.P. (2006). A study of mass transfer resistance in membrane gas–liquid contacting processes. *J. Membr. Sci.* 272, 103–115.