



HAL
open science

A new hybrid Bayesian network approach for modeling reliability

Florence Petiet, Olivier Francois, Laurent Bouillaut

► **To cite this version:**

Florence Petiet, Olivier Francois, Laurent Bouillaut. A new hybrid Bayesian network approach for modeling reliability. ESREL2018, European Safety and Reliability Conference, Jun 2018, Trondheim, Norway. pp.765-771, <10.1201/9781351174664-95>. <hal-01816353>

HAL Id: hal-01816353

<https://hal.science/hal-01816353v1>

Submitted on 15 Jun 2018

HAL is a multi-disciplinary open access archive for the deposit and dissemination of scientific research documents, whether they are published or not. The documents may come from teaching and research institutions in France or abroad, or from public or private research centers.

L'archive ouverte pluridisciplinaire **HAL**, est destinée au dépôt et à la diffusion de documents scientifiques de niveau recherche, publiés ou non, émanant des établissements d'enseignement et de recherche français ou étrangers, des laboratoires publics ou privés.



HAL Authorization

A new hybrid Bayesian network approach for modeling reliability

F. Petiet, O. François & L. Bouillaut

Gretia, Ifsttar, Univ. Paris Est, France

ABSTRACT: In this paper, a hybrid discrete-continuous Graphical Duration Models is proposed. Since the interest of the Weibull density was demonstrated for reliability analysis, this paper focuses on the use of Weibull densities for modeling sojourn times in each state of the system. This extension of the standard GDM requires a specific structure that we call Weibull-Hybrid Graphical Duration Models (W-HGDM). The main contribution of this study lays in the proposal of a specific inference algorithm for such hybrid networks. Finally, comparisons of reliability estimation will be proposed for both standard GDM and W-HGDM.

1 GENERAL INTRODUCTION

Reliability analysis is an integral part of system design and operating, especially for systems performing critical applications.

A wide range of works about reliability analysis is available in the literature.

Most of the time, the system failure is caused by the failure of one or more components. In this case, it is possible to use statistical distributions as the exponential distribution to model the lifetime. The Weibull Distribution (Weibull 1951) allows to describe each phase of the bathtub curve. In (Bertholon 2001) a new modeling of aging is proposed.

These distributions do not allow to focus on the dynamics of degradation. They cannot be applied to a system that is repaired when it fails. They cannot be used to assess the expected number of failures during the warranty period, or maintain a minimum mission reliability, or determine when to replace or overhaul a system. These methods are often called "classics".

Dynamic models explicitly take into account the temporal aspect modeling the evolution of the degradation of the system over time by stochastic methods (Cocozza-Thivent 1997). In order to address the reliability characteristics of complex repairable systems, a process is often used instead of a distribution, such as a Poisson process, a Gamma process, or a Weibull process.

Rather than considering the different components of the system, it is also possible to consider the whole system. Several methods are commonly used to model the different states of a dynamic system, in order to analyze its reliability, such as Markov Chain, Petri net, or Bayesian Network (Demri 2009).

Recent works have shown the interest of using Bayesian networks (BN) (Jensen 1996) in the field of reliability. For example (Boudali & Dugan 2005) shows how to model the reliability of a complex system using Bayesian networks.

(Weber & Jouffe 2003) explains how to use dynamic Bayesian networks (DBN) (Murphy 2002) to study the reliability of a multi-state system that depends on a certain context.

However DBN suppose that the sojourn time in each state are exponentially distributed, whereas most of the industrial applications underline non Markovian behaviors. In these cases, a Markovian degradation process modeling can introduce non negligible biases.

So an original Bayesian Network structure was proposed, named Graphical Duration Models (GDM), in order to fit systems whose sojourn time in each state are not necessary exponentially distributed (Donat, Leray, Bouillaut, & Aknin 2010). A GDM is characterized by a duration variable, allowing the use of any kind of distribution for modeling the sojourn time in each state of the considered system.

However the complexity is directly related to the size of the discrete space of the sojourn time variable. It can induce some technical problems in terms of storage capacity and computation time. A solution could be to consider a continuous duration variable.

In the theory of Bayesian Networks, there are several approaches that contain both continuous and discrete variables.

In hybrid Bayesian networks, where both discrete and continuous variables appear simultaneously, it is possible to apply inference schemes similar to those for discrete variables. The first model that allowed

exact inference in hybrid networks was based on the conditional Gaussian (CG) distribution (Lauritzen & Lauritzen 1992)

The restriction of discrete variables with continuous parents in CG may also be partially lifted using logit or probit function, generalized in the multinomial case by the softmax function (Murphy 1999)

Another way to lift the restriction caused by discrete variables with continuous parents is the using of a mixture of exponentials (Koller, Lerner, & Angelov 1999), but the inference is approximated.

The Mixture of Truncated Exponential model has been introduced in (Moral, Rumí, & Salmerón 2001). The advantage with respect to CG is that discrete nodes with continuous parents are allowed and inference can be exact (Cobb & Shenoy 2006).

Given that hybrid approaches thus exist in the Bayesian Network framework, such a perspective could be envisaged in a Graphical Duration Model.

According to expert feedback, sojourn-time variables follow a Weibull distribution in many systems (Weibull 1951).

Our goal is to integrate sojourn-time variables following a Weibull distribution in a graphical duration model by proposing a new approach.

First, this paper will briefly describe the formalisms of the Bayesian Networks of the Graphical Duration Models. We then introduce the our proposed formalism named Weibull-Hybrid Graphical Duration Models (W-HGDM) and the inference algorithm associated.

Then a toy system is introduced. Before some conclusions and prospects, a comparison of reliability analysis results, obtained from both Graphical Duration Models and Weibull-Hybrid Graphical Duration Models approaches, will be done.

2 INTRODUCTION OF THE FORMALISM

2.1 Bayesian Network

Bayesian Networks (Jensen 1996) are mathematical tools relying on the probability theory and the graph theory. They allow to qualitatively and quantitatively represent uncertain knowledge.

Bayesian Networks are Probabilistic Graphical Models that allow to intuitively represent the distribution of a set of random variables $\mathbf{X} = (X_1, \dots, X_N)$. Basically, a BN is defined as a pair $\mathcal{M} = (\mathcal{G}, (p_n)_{1 \leq n \leq N})$. $\mathcal{G} = (\mathbf{X}, \mathcal{E})$ is a Directed Acyclic Graph in which each node i is associated to a random variable X_i , that takes its values in a finite and countable set χ_i , and in which each directed arc $(i, j) \in \mathcal{E}$ represents dependencies between random variables X_i and X_j . $(p_n)_{1 \leq n \leq N}$ is a set of Conditional Probability Distributions (CPD) such that each p_n denote the conditional probability distribution associated to random variable X_n given its parents X_{pa_n} , pa_n referring to the sequence of parents indices of the random

variable X_n in \mathcal{G} .

The conditional independence relationships introduced by the arcs of the graph enable to factor the joint probability distribution of the set of random variables \mathbf{X} as follows :

$$P(\mathbf{X}) = P(X_1, \dots, X_N) = \prod_{n=1}^N P(X_n | X_{\text{pa}_n}) \quad (1)$$

Besides, tools have been developed to automatically learn the structure and the parameters of the graph and those of the CPD from complete or incomplete data or if a priori knowledge is available (e.g. expert opinion) (Neapolitan 2003).

Using BN is particularly interesting because of the possibility to propagate knowledge through the network. Indeed, various inference algorithms can be used to compute marginal probabilities of the system variables. One of the most classical inference procedures relies on the use of a junction tree (Lauritzen & Spiegelhalter 1988). Nevertheless, in our experiments, we use the elimination algorithm (Dechter 1999). This choice is motivated by the simplicity and the efficiency of the method.

2.2 Dynamic Bayesian Network

Inspired by the formalism of classical BN, the Dynamic Bayesian Networks (DBN) framework (Murphy 2002) allowed to unify many approaches from modeling of time series such as HMMs. A DBN aims to model the probability distribution of a random variables set $(\mathbf{X}_t)_{1 \leq t \leq T} = (X_{1,t}, \dots, X_{N,t})_{1 \leq t \leq T}$. It consists of a pair of Bayesian Networks $(\mathcal{M}_1, \mathcal{M}_\rightarrow)$. \mathcal{M}_1 defines the prior distribution $P(X_{1,1}, \dots, X_{N,1})$ as in (1). \mathcal{M}_\rightarrow defines the transition model which describes the dependencies between variables in slice $t-1$ and variables in slice t , i. e. the distribution of $\mathbf{X}_t | \mathbf{X}_{t-1}$.

$$\begin{aligned} P(\mathbf{X}_t | \mathbf{X}_{t-1}) &= P(X_{1,t}, \dots, X_{N,t} | X_{1,t-1}, \dots, X_{N,t-1}) \\ &= \prod_{n=1}^N P(X_{n,t} | X_{\text{pa}_{n,t}}) \end{aligned} \quad (2)$$

where $\text{pa}_{n,t}$ refers to the sequence of parents indices of the random variable $X_{n,t}$ in the graph of \mathcal{M}_\rightarrow .

A Dynamic Bayesian Network is actually a static Bayesian Network, that is repeated several times. So DBN inherit the convenient properties of static BN, particularly with regard to learning and inference.

The state of the system at future time $t+1$, \mathbf{X}_{t+1} , is decided by the system state at the current time t , \mathbf{X}_t , and does not depend on the state at earlier time instants $1, \dots, t-1$; and the conditional probability distributions of \mathcal{M}_\rightarrow do not depend on the slice t ; so the distribution of time spent in each state is geometric. Whereas most of industrial applications have not this behavior. Such a modeling can introduce non negligible biases in the estimations.

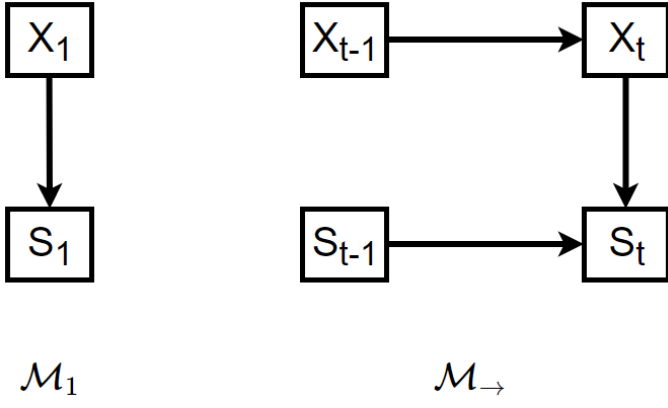

Figure 1: Discrete Duration Graphical Model

2.3 Graphical Duration Model

A Graphical Duration Model (Donat, Leray, Bouilaut, & Aknin 2010) relies on the two following variables : the system state X_t and the duration variable S_t describing the time spent in any system state (remaining sojourn time) (fig. 1).

Firstly, the Conditional Probability Distribution associated with the distribution of the initial system state is defined as follows, over the discrete and finite domain $\Omega_X = \{1, \dots, N_X\}$:

$$P(X_1 = i) = P_{X_1}(i) \quad (3)$$

The initial sojourn-time CPD gives the distributions for each initial state. This CPD is defined over the discrete and finite domain $\Omega_S = \{1, \dots, N_S\}$:

$$P(S_1 = k | X_1 = i) = P_{S_1}(i, k) \quad (4)$$

Then, it is necessary to define the system state and the Sojourn-time transition CPDs.

A transition occurs if and only if $S_{t-1} = 1$.

$$P(X_t = j | X_{t-1} = i, S_{t-1} = 1) = Q^{sys}(i, j) \quad (5)$$

where Q^{sys} is a $N_X \cdot N_X$ matrix, called static system transition matrix.

A new sojourn-time is selected according to the following CPD :

$$P(S_t = k | X_t = i, S_{t-1} = 1) = F^{sys}(i, k) \quad (6)$$

where F^{sys} is a $N_X \cdot N_S$ matrix.

While there is no transition, the system deterministically remains in the previous state i :

$$P(X_t = j | X_{t-1} = i, S_{t-1} \geq 2) = I(i, j) \quad (7)$$

and the sojourn-time in the current state is decreased deterministically by one unit :

$$P(S_t = k | X_t = i, S_{t-1} = k' \geq 2) = \begin{cases} 1 & \text{if } k = k' - 1 \\ 0 & \text{otherwise} \end{cases} \quad (8)$$

2.4 Reliability computation

Let assume that the set of system state Ω_X is partitioned into two sets \mathcal{U} and \mathcal{D} respectively for "up" states and for "down" states (i.e. OK and failure situations).

The discrete-time system reliability is defined as the function $R : \mathbf{N}^* \mapsto [0, 1]$ where $R(t)$ represents the probability that the system has always stayed in an up state until moment t , i.e. $R(t) = P(X_1 \in \mathcal{U}; \dots; X_t \in \mathcal{U})$.

In addition, it is possible to derive some interesting metrics such as the failure rate or the MTTF (Pham 2006) from the reliability definition.

Hence, this issue boils down to an inference problem, i.e. to the computation of $P(X_1 \in \mathcal{U}; \dots; X_t \in \mathcal{U})$

The system cannot repair itself. The failure state is absorbing. The reliability is then equal to the availability, ie $P(X_1 \in \mathcal{U}; \dots; X_t \in \mathcal{U}) = 1 - P(X_t \in \mathcal{D})$.

Then the reliability computation is reduced to the computation of the marginal distribution of X_t :

$$\begin{aligned} R(t) &= P(X_t \in \mathcal{U}) \\ &= 1 - \sum_{\substack{X_1, \dots, X_{t-1} \\ S_1, \dots, S_{t-1}}} P(X_t \in \mathcal{D}, X_{t-1}, \dots, X_1, S_{t-1}, \dots, X_1) \\ &= 1 - \sum_{\substack{X_1, \dots, X_{t-1} \\ S_1, \dots, S_{t-1}}} \prod_{u=1}^{t-1} P(X_u | \text{pa}(X_u)) \times P(S_u | \text{pa}(S_u)) \\ &= 1 - \sum_{\substack{X_1, \dots, X_{t-1} \\ S_1, \dots, S_{t-1}}} \prod_{u=1}^{t-1} P(X_u | \text{pa}(X_u)) \times P(S_u | \text{pa}(S_u)) \quad (9) \end{aligned}$$

2.5 Limitation of GDM

The larger N_S is, the more accurate the representation of the sojourn-time distribution. On the other hand, choosing a too large N_S value will have immediate consequences on both the space needed to store the Conditional Probability Distributions, i.e. $N_X \cdot N_S$ values, and the time complexity of inference.

That can induce some technical problems in terms of storage capacity and computation time. A solution could be to consider a continuous duration variable. With c the number of parameters needed by the chosen distribution, the CPD will be constituted of $N_X \cdot c$ values, so the space needed to store the continuous CPD is smaller than if they are discrete.

Since the interest of the Weibull density was demonstrated for reliability analysis (Weibull 1951), this paper focuses on the use of Weibull densities for modeling sojourn times in each state of the system.

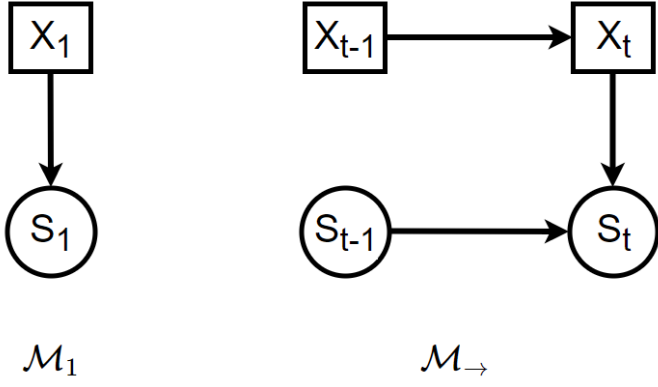

Figure 2: Continuous Duration Graphical Model

3 WEIBULL-HYBRID GRAPHICAL DURATION MODELS

In the following paragraphs, we propose a new formalism to represent the evolution of a dynamic system over time, in order to estimate its reliability. This particular model is called Weibull-Hybrid Graphical Duration Models (W-HGDM). In the following, we will describe its conditional probability distributions, and an inference algorithm in order to compute the reliability.

3.1 Generalities

The collection $(X_t)_{1 \leq t \leq T}$ represents the system state over a sequence of length T . The collection $(S_t)_{1 \leq t \leq T}$ represents the remaining time before a system state modification. More clearly, we refer to the random variable S_t as the remaining sojourn time in the current system state. These variables are called duration variables or sojourn-time variables. A Weibull-Hybrid Graphical Duration Model is illustrated in figure 2.

Expressions (3), (4), (5), (6), (7) and (8) become expressions (10), (11), (13), (14), (15) and (16).

The Conditional Probability Distribution associated with the distribution of initial system state must be defined as follows, over the discrete and finite domain $\Omega_X = 1, \dots, N_X$:

$$P(X_1 = i) = p_i^{ini} \quad (10)$$

The initial sojourn-time CPD gives the distribution for each initial state, it is defined over the continuous domain $\Omega_S =]0, +\infty[$:

$$f_{S_1|X_1=i} = f_{\mathcal{W}_{\alpha_i, \beta_i}} \quad (11)$$

with

$$f_{\mathcal{W}_{\alpha, \beta}}(s) = \frac{\beta}{\alpha} \left(\frac{s}{\alpha}\right)^{\beta-1} e^{-\left(\frac{s}{\alpha}\right)^\beta} \quad (12)$$

where α is the scale parameter and β the shape parameter.

Then, it is necessary to define the system state and the sojourn-time transition CPD :

A transition occurs if and only if $S_{t-1} < 1$.

$$P(X_t = j | X_{t-1} = i, S_{t-1} < 1) = Q^{sys}(i, j) \quad (13)$$

where Q^{sys} is a $N_X \cdot N_X$ matrix, called static system transition matrix.

A new sojourn-time is selected according to the following CPD :

$$f_{S_t=s|S_{t-1}<1, X_t=i} = f_{\mathcal{W}_{\alpha_i, \beta_i}}(s) \quad (14)$$

While there is no transition, the system deterministically remains in the previous state i :

$$P(X_t = j | X_{t-1} = i, S_{t-1} > 1) = I(i, j) \quad (15)$$

and the sojourn-time in the current state is decreased deterministically by one unit :

$$f(S_t = s | X_t = i, S_{t-1} = s' > 1) = \begin{cases} 1 & \text{if } s = s' - 1 \\ 0 & \text{otherwise} \end{cases} \quad (16)$$

3.2 Inference

As shown in 2.4, the reliability of a non-repairable system is equal to the availability of the system :

$$\begin{aligned} R(t) &= P(X_t \in \mathcal{U}) \\ &= 1 - \sum_{\substack{X_1, \dots, X_{t-1} \\ S_1, \dots, S_{t-1}}} P(X_t \in D, X_{t-1}, \dots, X_1, S_{t-1}, \dots, S_1) \\ &= 1 - \sum_{\substack{X_1, \dots, X_{t-1} \\ S_1, \dots, S_{t-1}}} \prod_{u=1}^{t-1} P(X_u | \text{pa}(X_u)) \times f(S_u | \text{pa}(S_u)) \\ &= 1 - \sum_{\substack{X_1, \dots, X_{t-1} \\ S_1, \dots, S_{t-1}}} \prod_{u=1}^{t-1} P(X_u | \text{pa}(X_u)) \times f(S_u | \text{pa}(S_u)) \quad (17) \end{aligned}$$

We have to compute successively the following distributions :

- $\Phi_{t,u} = P(X_t | X_u, S_{u-1})$ for $u \in \llbracket 2; t-1 \rrbracket$ and $\Phi_{t,1} = P(X_t | X_1)$
- $\Lambda_{t,u} = P(X_t | X_{u-1}, S_{u-1})$ for $u \in \llbracket 2; t \rrbracket$ and $\Lambda_{t,1} = P(X_t)$

The required distributions are expressed as follows:

The computation in (18) and (19) can be developed as follows :

In (18) :

For $u \in \llbracket 2; t-1 \rrbracket$

$$P(X_t | X_{t-q}, S_{t-q-1} = s) = \quad (23)$$

$$\begin{aligned} \Phi_{t,u} &= \int_0^\infty P(X_t | X_u, S_u = s_u) f(S_u = s_u | X_u, S_{u-1}) ds_u \\ &= \int_0^\infty \Lambda_{t,u+1} \times f(S_u = s_u | X_u, S_{u-1}) ds_u \quad (18) \end{aligned}$$

$$\begin{cases} Q^{(q)} & \text{if } s < 1 \\ Q^{sys} * Q^{(q-1)} & \text{if } 1 < s < 2 \\ \dots & \\ Q^{sys} * Q^{(q-j)} & \text{if } j < s < j+1 \\ \dots & \\ Q^{sys} & \text{if } q < s < q+1 \\ I & \text{if } q+1 < s \end{cases} \quad (24)$$

and

$$\text{with } Q^{(q)}(x, y) = \sum_{k=1}^q \int_{k-1}^k f_{W_{\alpha_x, \beta_x}}(s) ds \times [Q^{sys} Q^{(q-k)}](x, y) + \int_q^\infty f_{W_{\alpha_x, \beta_x}}(s) ds \times I(x, y).$$

$$\begin{aligned} \Lambda_{t,u} &= \sum_{x \in \Omega_{X_u}} P(X_t | X_u = x, S_{u-1}) P(X_u = x | X_{u-1}, S_{u-1}) \\ &= \sum_{x \in \Omega_{X_u}} \Phi_{t,u} \times P(X_u = x | X_{u-1}, S_{u-1}) \quad (19) \end{aligned}$$

In (19) :

$$P(X_t | X_{t-q-1}, S_{t-q-1} = s) = \quad (25)$$

$$\begin{aligned} \text{For } u = 1 \\ \Phi_{t,1} &= \int_0^\infty P(X_t | X_1, S_1 = s_1) f(S_1 = s_1 | X_1) ds_u \\ &= \int_0^\infty \Lambda_{t,2} f(S_1 = s_1 | X_1) ds_u \quad (20) \end{aligned}$$

$$\begin{cases} Q^{sys} * Q^{(q)} & \text{if } s < 1 \\ Q^{sys} * Q^{(q-1)} & \text{if } 1 < s < 2 \\ \dots & \\ Q^{sys} * Q^{(q-j)} & \text{if } j < s < j+1 \\ \dots & \\ Q^{sys} & \text{if } q < s < q+1 \\ I & \text{if } q+1 < s \end{cases} \quad (26)$$

and

$Q^{sys} \times Q^{(q)}$ is actually the natural transition of the system between q slices.

$$\begin{aligned} \Lambda_{t,1} &= \sum_{x \in \Omega_{X_1}} P(X_t | X_1 = x) P(X_1 = x) \\ &= \sum_{x \in \Omega_{X_1}} \Phi_{1,1} P(X_1 = x) \quad (21) \end{aligned}$$

4 ILLUSTRATIONS

The W-HGDM used has been implemented in MATLAB[®] environment, using the open source Bayes Net Toolbox (BNT).

The elements required by the computation (18) are given by (19), (14) and (16) ; and those required by (20) are given by (19) and (11).

4.1 Test

To validate this algorithm, we consider a two-state system, one of the states being "up", the other being "down". The reliability can be written as follows :

The elements required by the computation (19) are given by (18), (13) and (15) ; and those required by (21) are given by (18) and (10).

Equations 18, 19, 20, 21 define an iterative algorithm, that give at the end : $\Lambda_{t,1} = P(X_t)$, that allows to have the value of the reliability :

$$\begin{aligned} R_{sys}(t) &= P(X_1 \in \mathcal{U} \cap \dots \cap X_t \in \mathcal{U}) \\ &= P(S_1 \geq t | X_1 \in \mathcal{U}) P(X_1 \in \mathcal{U}) \\ &= 1 - F_{W_{\alpha_u, \beta_u}}(t) \\ &= e^{-\left(\frac{t}{\alpha_u}\right)^{\beta_u}} \quad (27) \end{aligned}$$

$$R(t) = 1 - P(X_t \in \mathcal{D}) = \sum_{x \in \mathcal{U}} P(X_t = x) \quad (22)$$

The application of the inference algorithm presented in 3.2 to such a model is supposed to return a Weibull distribution.

Table 1: System transition Conditional Probability Table

	State 1	State 2	State 3
state 1	0	0.9	0.1
state 2	0	0	1
state 3	0	0	1

Table 2: Sojourn-time distribution for each state

	α	β
State 1	30	1
State 2	20	1

The figure 3 shows that the estimated reliability is exactly the reliability given by the Weibull distribution.

4.2 Comparison with standard GDM

Let's illustrate our approach using a GDM modeling the behavior of a 3-states production machine, i. e. $\Omega_X = \{1, 2, 3\}$, with $\mathcal{D} = \{3\}$. The transition rate between system states is given in table 1. The parameter of the Weibull distribution that characterize the sojourn-time variable when a transition occurs are given in table 2. The algorithm presented in subsection 3.2 was used to make the computations.

A standard GDM is then built. The state system variable of this standard GDM model has the same static system transition matrix as the W-HGDM (table 1). The distribution of sojourn-time variable of this standard GDM model is constructed by discretizing the continuous Weibull distribution, with the same parameters as the W-HGDM (table 2), and with $N_S = 150$ (Donat, Bouillaut, Aknin, Leray, & Bondeux 2008).

The method presented in 3.2 has been used to compute reliability estimations presented in figure 4.

We obtain the same results with both methods.

5 CONCLUSIONS

In this paper, a new hybrid approach for the duration model in which sojourn-time follows a Weibull distribution, called Weibull-Hybrid Graphical Duration Model, has been proposed. An associated inference algorithm has been therefore developed and introduced allowing the estimation of the reliability of the system in such models.

Finally, first results introduced in this paper underline the feasibility of the proposed approach in terms of inference accuracy. This validates the interest we have had in proposing such a hybrid approach for the modeling of degradation dynamics. Indeed, the expected advantage of W-HGDM leads mainly in the non discretization of the sojourn variable in GDM that can become a drag to reliability computation for complexity reasons.

Now, many things can be done and investigated through this new approach. The first perspective is to go further in the algorithm validation, by comparing the complexities and the speeds between stan-

dard GDM and W-HGDM. We also have planned to add some nodes to the presented W-HGDM, such as context variables, and, of course, maintenance actions. The long-term goal of this study is to improve VirMaLab (Virtual Maintenance Laboratory, fig. 5), a generic decision support tool developed by the GRETTIA (Bouillaut, Aknin, Donat, & Bondeux 2011) in order to evaluate, optimize and compare maintenance strategies for discrete state space system, by allowing sojourn-time variables to follow a Weibull distribution.

REFERENCES

- Bertholon, H. (2001). *Une modélisation du vieillissement*. Ph. D. thesis, Université Joseph Fourier, Grenoble.
- Boudali, H. & J. B. Dugan (2005). A discrete-time bayesian network reliability modeling and analysis framework. *Reliability Engineering and System Safety* 87, 337–349.
- Bouillaut, L., P. Aknin, R. Donat, & S. Bondeux (2011). VirMaLab - A generic approach for optimizing maintenance policies of complex systems. In *WCRR 2011 - 9th World Congress on Railway Research*, Lille, France, pp. 11p. WCRR. WCRR 2011 - 9th World Congress on Railway Research, Lille, FRANCE, 22-/05/2011 - 26/05/2011.
- Cobb, B. R. & P. P. Shenoy (2006). Inference in hybrid bayesian networks with mixtures of truncated exponentials. *International Journal of Approximate Reasoning* 41(3), 257 – 286.
- Coccoza-Thivent, C. (1997). *Processus stochastiques et fiabilité des systèmes*. Mathématiques et Applications. Springer Berlin Heidelberg.
- Dechter, R. (1999). Bucket elimination: A unifying framework for reasoning. *Artificial Intelligence* 113(1), 41 – 85.
- Demri, A. (2009). *Reliability estimation of mechatronic systems using functional and dysfunctional analysis*. Ph. D. thesis, Université d'Angers.
- Donat, R., L. Bouillaut, P. Aknin, P. Leray, & S. Bondeux (2008, June). Specific graphical models for analyzing the reliability. In *2008 16th Mediterranean Conference on Control and Automation*, pp. 621–626.
- Donat, R., P. Leray, L. Bouillaut, & P. Aknin (2010, January). A dynamic bayesian network to represent discrete duration models. *Neurocomputing* 73(4-6), 570–577.
- Jensen, F. V. (1996). *Introduction to Bayesian Networks* (1st ed.). Secaucus, NJ, USA: Springer-Verlag New York, Inc.
- Koller, D., U. Lerner, & D. Angelov (1999). A general algorithm for approximate inference and its application to hybrid bayes nets. pp. 324–333.
- Lauritzen, S. L. & S. L. Lauritzen (1992). Propagation of probabilities, means and variances in mixed graphical association models. *Journal of the American Statistical Association* 87, 1098–1108.
- Lauritzen, S. L. & D. J. Spiegelhalter (1988). Local computations with probabilities on graphical structures and their application to expert systems. *Journal of the Royal Statistical Society. Series B (Methodological)* 50(2), 157–224.
- Moral, S., R. Rumí, & A. Salmerón (2001). Mixtures of truncated exponentials in hybrid bayesian networks. In *Proceedings of the 6th European Conference on Symbolic and Quantitative Approaches to Reasoning with Uncertainty, ECSQARU '01*, London, UK, UK, pp. 156–167. Springer-Verlag.
- Murphy, K. P. (1999). A variational approximation for bayesian networks with discrete and continuous latent variables. In *Proceedings of the Fifteenth Conference on Uncertainty in Artificial Intelligence, UAI'99*, San Francisco, CA, USA, pp. 457–466. Morgan Kaufmann Publishers Inc.
- Murphy, K. P. (2002). *Dynamic Bayesian Networks: Representen-*

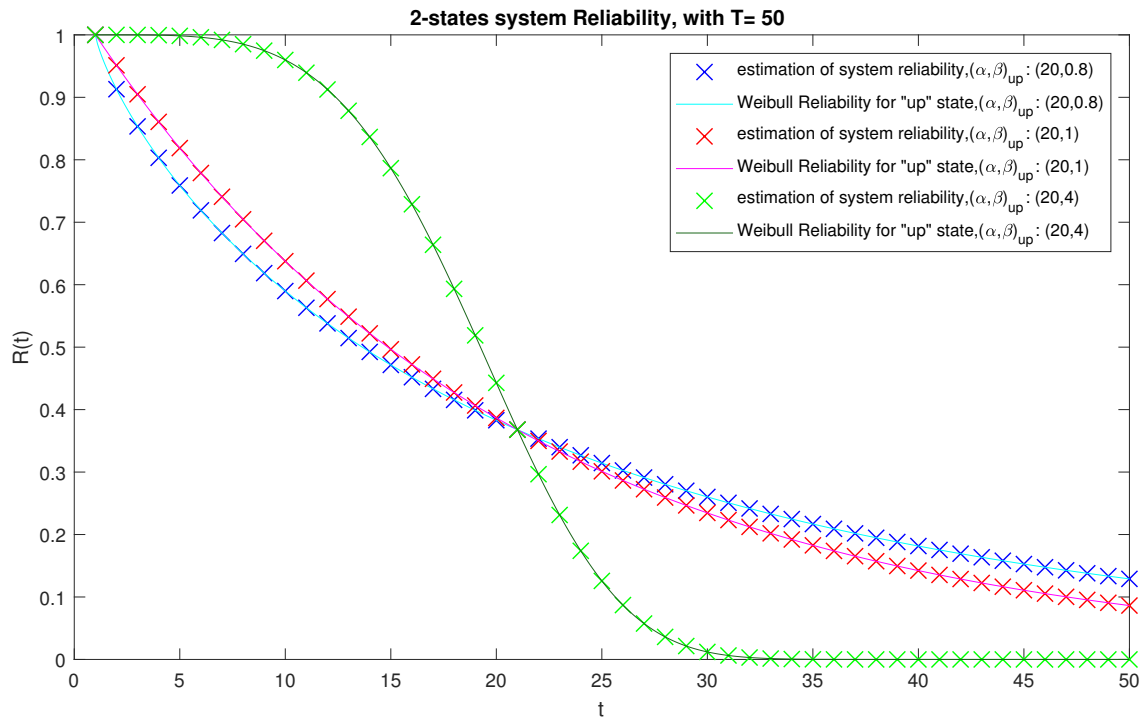

Figure 3: Reliability of a 2 states-sytem and of weibull distributions

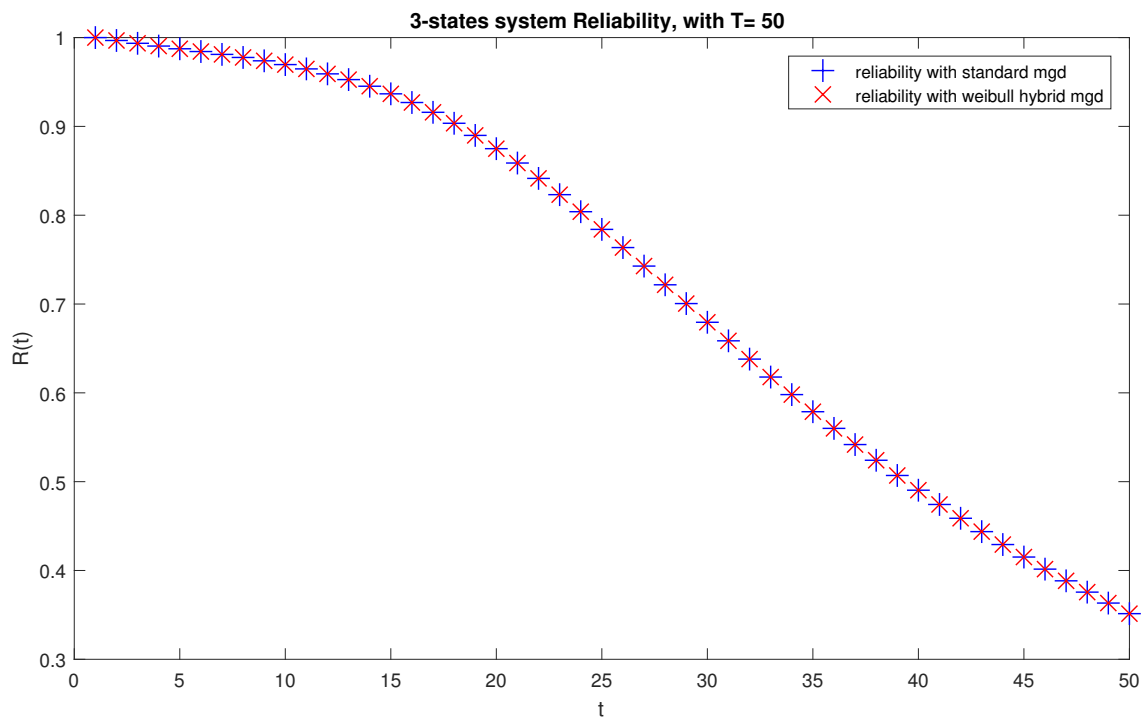

Figure 4: Comparison between discrete GDM and W-HGDM

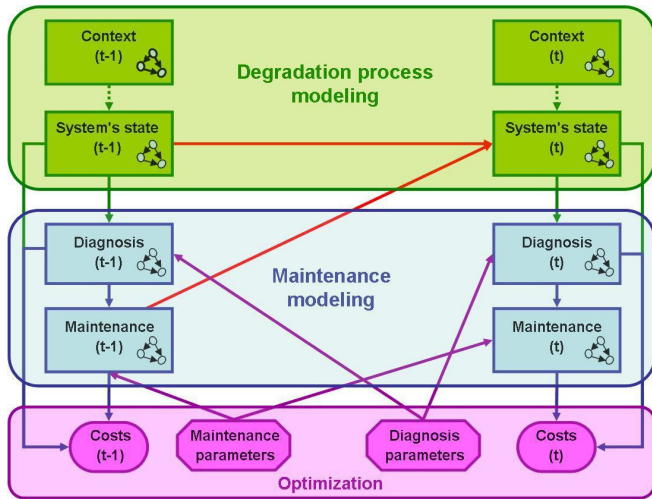

Figure 5: Virtual Maintenance Laboratory

tation, Inference and Learning. Ph. D. thesis, University of California, Berkeley.

Neapolitan, R. E. (2003). *Learning Bayesian Networks*. Upper Saddle River, NJ, USA: Prentice-Hall, Inc.

Pham, H. (2006). *System Reliability Concepts*, pp. 9–75. London: Springer London.

Weber, P. & L. Jouffe (2003, June). Reliability modelling with dynamic bayesian networks. pp. 57–62. IFAC.

Weibull, W. (1951). A statistical distribution function of wide applicability. *Journal of applied mechanics* 18(3), 293–297.