



**HAL**  
open science

## Multi-variable model reduction of smart structure in active vibration control

Peng Wang, Gérard Scorletti, Anton Korniienko, Manuel Collet

► **To cite this version:**

Peng Wang, Gérard Scorletti, Anton Korniienko, Manuel Collet. Multi-variable model reduction of smart structure in active vibration control. 9th IFAC ROCOND'18, Sep 2018, Florianópolis, Brazil. pp.441-446, 10.1016/j.ifacol.2018.11.152 . hal-01800664

**HAL Id: hal-01800664**

**<https://hal.science/hal-01800664>**

Submitted on 12 Jun 2018

**HAL** is a multi-disciplinary open access archive for the deposit and dissemination of scientific research documents, whether they are published or not. The documents may come from teaching and research institutions in France or abroad, or from public or private research centers.

L'archive ouverte pluridisciplinaire **HAL**, est destinée au dépôt et à la diffusion de documents scientifiques de niveau recherche, publiés ou non, émanant des établissements d'enseignement et de recherche français ou étrangers, des laboratoires publics ou privés.

# Multi-variable model reduction of smart structure in active vibration control

Peng Wang<sup>\*,\*\*</sup> Gerard Scorletti<sup>\*</sup> Anton Kornienko<sup>\*</sup>  
Manuel Collet<sup>\*\*</sup>

<sup>\*</sup> *Laboratoire Ampère, UMR CNRS 5005, Ecole centrale de Lyon, Université de Lyon, Ecully, France, peng.wang@doctorant.ec-lyon.fr, {gerard.scorletti,anton.kornienko}@ec-lyon.fr*

<sup>\*\*</sup> *LTDS UMR CNRS 5513, Ecole centrale de Lyon, Université de Lyon, Ecully, France, manuel.collet@ec-lyon.fr*

---

**Abstract:** In this paper, a new model reduction method is proposed to further reduce the structural model obtained by classical model reduction techniques. The reduction is in the frequency domain and is able to obtain a reduce-order model that is close to the initial model in a specified frequency range. The reduced-order model keeps the poles of the initial model in the frequency range of interest. LMI is used to minimize the relative error. This method is effective on both single-input single-output (SISO) system and multi-input multi-output (MIMO) system. The application on a beam-piezo model with multiple actuators and sensors validates its effectiveness.

Keywords: model reduction, MIMO system, pole truncation, modal form, relative error, LMI constraint

---

## 1. INTRODUCTION

Light structure has attracted increasing attentions for many applications. The light weight and low production cost are the main advantages. However, the disadvantage is that it is always flexible thus more susceptible to vibration problem. Active vibration control with smart materials becomes an objective of crucial economic importance. With the development of optimal control theories, more and more efficient controller synthesis methods have been applied to solve active vibration control problems, for example LQR control in Wang (2016),  $H_2$  control in Stavroulakis et al. (2005),  $H_\infty$  control in Zhang et al. (2016), etc. In order to obtain a low-order controller, a low-order model is necessary.

In actual applications, the controller is always designed to reject the excitation in a specific frequency range that covers a finite number of vibration modes. The controller design methods are frequency based approaches. The quality of a low-order model in frequency response is critical to obtain an effective design. Therefore, a low-order model should refer to a model whose frequency response is close, which means the correspondence around both resonance responses and anti-resonance responses, to the full system only in the frequency range of interest that covers the modes to be controlled. To obtain a low-order model, an initial full-order model of the structure should be first built.

The actual smart structure has an infinite number of physical Degree of Freedom (DOF) and dimension. Finite element method (FEM) is always applied to discretize the structure and gives a mathematical expression with infinite DOF and very large dimension. Then, it is simplified by

classical model reduction techniques. Modal Displacement Method, presented by Besselink et al. (2013), is based on the free vibration modes, only the first several modes that correspond to the lowest eigenfrequencies are kept while higher modes are truncated. There are also projection-based model reduction techniques. They are variations of Petrov-Galerkin Projection, see Antoulas et al. (2010), where it is aimed to find two modeling subspaces used as the base change of the initial modal. For example Krylov Subspace Projection in Liew and Pinsky (2010) and Rational Interpolation in Beattie and Gugercin (2014). Balanced Truncation, see Heinkenschloss et al. (2008), reduces the model by neglecting the states with low controllability and observability. Rayleigh-Ritz Method, see Seuaciuc-Osório and Daqaq (2009), approximates the solution of the eigenfunctions with infinite DOF by the sum of a finite set of orthogonal functions. The common point of the above mentioned classical model reduction techniques is that they focus on the global behavior of the structure. They are able to approximate the actual system with infinite DOF and large dimension by a model with finite DOF and low dimension in form of state-space representation or transfer function. It makes possible to design the controller because usual controller synthesis methods cannot be applied on an infinite DOF system and a large dimensional model needs high computing cost. However, none of them are able to obtain a low-order model by flexibly specifying a certain frequency range. For example, although Modal Displacement Method truncates the higher order modes which implies the ignorance of high frequency dynamics, the low frequency dynamics are still kept which should also be neglected. Therefore, new method should be developed to further reduce the model obtained by these classical

model reduction methods, considered as initial full-order model, by considering frequency range.

This paper proposes two steps to solve the above problem. First, truncate the poles outside the frequency range of interest. This can be achieved by applying the Aggregation Technique, see Singh (1979), where the reduced-order model is obtained in the way that its poles belongs to a subset of the poles of the initial model, which allows us to choose the modes to be controlled. In this way, the reduced-order model will have the same resonance responses as the initial model in the frequency range of interest. Second, modify the reduced-order model such that the relative error between the initial model and the reduced-order model in the frequency range of interest is minimized. Although the truncation keeps the resonance responses, it introduces errors around anti-resonance responses. Minimizing the relative error helps match the anti-resonance responses because relative error allows us to capture the difference around anti-resonance responses. In addition, the reduced-order model based controller should also be able to stabilize the initial model, which is referred to as robust stability. In robust control, the error between two systems is always considered as an uncertainty and the Small Gain Theorem, see Zhou et al. (1995), is applied where the upper bound of the uncertainty in the frequency range of interest must be limited to ensure the existence of the robust controller. In the case when the resonance responses are already kept, the precision of anti-resonance responses becomes critical. However, it is not easy to match the anti-resonance responses with the poles already been fixed. In case of a multi-input multi-output (MIMO) system, it is even more difficult.

The specialty of the relative error minimization problem is that only the error over a specific frequency range is minimized. Instead of using weighting functions with a result very sensible to their choices, an extension of the so-called KYP lemma, see Popov and Georgescu (1973), and Loop-shifting, see Desoer and Vidyasagar (1975), is applied to transform this problem into Linear Matrix Inequality (LMI) constraints. The proposed method is effective on both single-input single-output (SISO) system and multi-input multi-output (MIMO) system.

The outline of this paper is as follows. Section 2 points out the model reduction problem. Section 3 explains the basic theory of the proposed model reduction method. Section 4 applies this method on the model of a smart structure. The conclusion is in Section 5.

*Notation:* Let us denote  $\Lambda(A)$  and  $\bar{\sigma}(A)$  respectively the set of the eigenvalue and the maximum singular value of a matrix  $A$ , as well as  $|\lambda|$  the norm of a complex number  $\lambda$ .

## 2. PROBLEM STATEMENT

Let us consider an initial MIMO system, denoted  $G$ , in the following state-space representation:

$$\begin{cases} \dot{x}(t) = A \cdot x(t) + B \cdot u(t) \\ y(t) = C \cdot x(t) + D \cdot u(t) \end{cases} \quad (1)$$

with  $A \in \mathbf{R}^{n \times n}$ ,  $B \in \mathbf{R}^{n \times n_u}$ ,  $C \in \mathbf{R}^{n_y \times n}$ ,  $D \in \mathbf{R}^{n_y \times n_u}$ .  $u(t)$  is the actuation input vector,  $y(t)$  the sensing output

vector, and  $x(t)$  the state vector. Define the frequency range of interest, denoted  $\Omega$ , as  $\Omega = \{\omega | 0 < \underline{\omega} \leq \omega \leq \bar{\omega}\}$ .

The problem is to compute a reduced-order model  $G_r$  in the following state-space representation:

$$\begin{cases} \dot{x}(t) = A_r \cdot x(t) + B_r \cdot u(t) \\ y(t) = C_r \cdot x(t) + D_r \cdot u(t) \end{cases} \quad (2)$$

with  $A \in \mathbf{R}^{n_r \times n_r}$ ,  $B \in \mathbf{R}^{n_r \times n_u}$ ,  $C \in \mathbf{R}^{n_y \times n_r}$ ,  $D \in \mathbf{R}^{n_y \times n_u}$ , and  $n_r < n$ , such that:

$$\Lambda(A_r) \subset \Lambda(A) \quad \text{and} \quad \forall \lambda \in \Lambda(A_r), |\lambda| \in \Omega. \quad (3)$$

and the relative error  $\Delta(j\omega)$ , defined as:

$$\Delta(j\omega) = G(j\omega)^{-1}(G(j\omega) - G_r(j\omega)),$$

satisfies:

$$\begin{aligned} \min_{G_r} \quad & \gamma \\ \text{such that} \quad & \forall \omega \in \Omega, \bar{\sigma}(\Delta(j\omega)) < \gamma \end{aligned} \quad (4)$$

## 3. MAIN RESULT

Conditions (3) and (4) are satisfied in two steps. First, the poles in the frequency range of interest, which correspond to the vibration modes to be controlled, are kept in  $G_r$  while all the other poles are truncated.  $A_r$  and  $B_r$  can be obtained with  $A_r$  satisfying (3). Second,  $C_r$  and  $D_r$  are modified to minimize the relative error defined in (4). A new theorem is proposed to transform (4) into LMI constraints.  $C_r$  and  $D_r$  are the solutions of the LMI problem.

### 3.1 Pole truncation

The idea of pole truncation comes from the Aggregation Technique, see Singh (1979). In order to truncate the specified poles, they must first be represented independently. Therefore, base change is done on the state space representation (1) to transform it into a modal form, equivalently named Diagonal Canonical Form in Williams and Lawrence (2007). The modal form of  $G$  in the shorthand for state-space representation is:

$$G = \begin{bmatrix} \hat{A}_1 & & & & \hat{B}_1 \\ & \ddots & & & \vdots \\ & & \hat{A}_p & & \hat{B}_p \\ & & & \ddots & \vdots \\ & & & & \hat{A}_q & \hat{B}_q \\ & & & & & \ddots \\ & & & & & & \hat{A}_n & \hat{B}_n \\ \hline \hat{C}_1 & \cdots & \hat{C}_p & \cdots & \hat{C}_q & \cdots & \hat{C}_n & \hat{D} \end{bmatrix} \quad (5)$$

where the dynamic matrix  $\hat{A}$  is block-diagonal and  $\Lambda(\hat{A}) = \Lambda(A)$ . Each block  $\hat{A}_i$  for  $i = 1, 2, \dots, n$  is either a  $1 \times 1$  scalar or a  $2 \times 2$  matrix. Denote  $\hat{A}_j$  for  $j = p, \dots, q$  with  $1 \leq p < q \leq n$  such that  $\forall \lambda \in \Lambda(\hat{A}_j), |\lambda| \in \Omega$ , then  $A_r$  and  $B_r$  are in the form below:

$$A_r = \begin{bmatrix} \hat{A}_p & & \\ & \ddots & \\ & & \hat{A}_q \end{bmatrix}, B_r = \begin{bmatrix} \hat{B}_p \\ \vdots \\ \hat{B}_q \end{bmatrix} \quad (6)$$

with  $\Lambda(A_r) \subset \Lambda(A)$ .

$A_r$  has smaller dimension implies that  $G_r$  has lower order.

*Remark 1.* Pole truncation also allows us to obtain  $C_r = [\hat{C}_p, \dots, \hat{C}_q]$  and  $D_r = \hat{D}$  which gives us  $G_r = (A_r, B_r, C_r, D_r)$ . We can call this method the Modal Form Truncation (MFT). However, such  $C_r$  and  $D_r$  can not assure a minimum relative error.

### 3.2 Relative error minimization

In this part,  $C_r$  and  $D_r$  will be modified while  $A_r$  and  $B_r$  stay unchanged. Condition (4) is reformulated as:

$$\min_{C_r, D_r} \gamma$$

such that  $\forall \omega \in (\underline{\omega}, \bar{\omega}), \bar{\sigma}(G(j\omega)^{-1}(G(j\omega) - G_r(j\omega))) < \gamma$  (7)

The major difficulty of this problem is the infinite number of constraints as it considers every frequency in a specific frequency range. Nevertheless, by introducing new matrix variables, this infinite number of constraints can be transformed into a finite number of constraints which defines a Linear Matrix Inequality (LMI) constraint.

*Theorem 2.* Let be  $G$ , an LTI continuous system with the state-space representation (1),  $G_r$ , a reduced model of  $G$  with the state-space representation (2), and  $\gamma$  a real positive number. The solution of (7) is obtained by solving the following LMI problem:

$$\min_{C_r, D_r, P \in \mathbb{C}^{n_a \times n_a}} \gamma^2$$

such that  $P + P^* < 0, K + K^* > 0$  (8)

where  $n_a = n + n_r$  and:

$$K = XN + Q,$$

$$X = \begin{bmatrix} P & 0 \\ C_r & D_r & 0 \\ 0 & 0 & \gamma^2 I \end{bmatrix}, N = \begin{bmatrix} \tilde{A} & \tilde{B} \\ 0 & -E_{r\delta} & 0 & F_{r\delta} \\ 0 & 0 & 0 & -I \\ 0 & 0 & 0 & \frac{I}{2} \end{bmatrix},$$

$$Q = \begin{bmatrix} B_\delta B_\delta^* / 2 & 0 & 0 & 0 \\ 0 & 0 & 0 & 0 \\ D_\delta B_\delta^* & 0 & D_\delta D_\delta^* / 2 & D_\delta \\ B_\delta^* & 0 & 0 & 0 \end{bmatrix},$$

$$\tilde{A} = \begin{bmatrix} A_\delta^* & 0 \\ 0 & A_{r\delta} \end{bmatrix}, \tilde{B} = \begin{bmatrix} C_\delta^* & 0 \\ 0 & B_{r\delta} \end{bmatrix},$$

$$E_{r\delta} = (I + \frac{j}{\underline{\omega}} A_r)^{-1}, F_{r\delta} = \frac{j}{\underline{\omega}} E_{r\delta} B_r$$

$$A_\delta = -\bar{\omega} I - j(1 - \frac{\bar{\omega}}{\underline{\omega}}) A (I + \frac{j}{\underline{\omega}} A)^{-1},$$

$$B_\delta = -j(1 - \frac{\bar{\omega}}{\underline{\omega}}) (I + \frac{j}{\underline{\omega}} A)^{-1} B,$$

$$C_\delta = C (I + \frac{j}{\underline{\omega}} A)^{-1},$$

$$D_\delta = D - \frac{j}{\underline{\omega}} C (I + \frac{j}{\underline{\omega}} A)^{-1} B,$$

$$A_{r\delta} = -\bar{\omega} I - j(1 - \frac{\bar{\omega}}{\underline{\omega}}) A_r (I + \frac{j}{\underline{\omega}} A_r)^{-1},$$

$$B_{r\delta} = -j(1 - \frac{\bar{\omega}}{\underline{\omega}}) (I + \frac{j}{\underline{\omega}} A_r)^{-1} B_r,$$

$$C_{r\delta} = C_r (I + \frac{j}{\underline{\omega}} A_r)^{-1},$$

$$D_{r\delta} = D_r - \frac{j}{\underline{\omega}} C_r (I + \frac{j}{\underline{\omega}} A_r)^{-1} B_r.$$

Problem (8) is a linear cost minimization problem. There exist efficient algorithms to solve this problem, see Boyd et al. (1994).

*Remark 3.* The order of the model is in fact reduced by MFT who selects the poles. Relative error minimization modifies the reduced-order model without changing the order. The controller synthesis methods used in active vibration control always lead to a controller who has the same order with the model. As a result, a low-order model leads to a low-order controller.

#### Proof.

The constraint in (7) can be interpreted as below:

$$\forall \omega \in (\underline{\omega}, \bar{\omega}),$$

$$\bar{\sigma}(G(j\omega)^{-1}(G(j\omega) - G_r(j\omega))) < \gamma$$

$$\Leftrightarrow \left( (G(j\omega)^* - G_r(j\omega)^*) G(j\omega)^{-*} \right)$$

$$\left( G(j\omega)^{-1}(G(j\omega) - G_r(j\omega)) \right) < \gamma^2$$

$$\Leftrightarrow \gamma^2 I - \left( G(j\omega) - G_r(j\omega) \right)^*$$

$$\left( G(j\omega) G(j\omega)^* \right)^{-1} \left( G(j\omega) - G_r(j\omega) \right) > 0$$

$$\Leftrightarrow \begin{bmatrix} G(j\omega) G(j\omega)^* & G(j\omega) - G_r(j\omega) \\ G(j\omega)^* - G_r(j\omega)^* & \gamma^2 I \end{bmatrix} > 0$$

by using the Schur complement, see Boyd et al. (1994).

If we define:

$$\Phi(j\omega) = \begin{bmatrix} G(j\omega)^* & I \\ 0 & G_r(j\omega) \\ 0 & (\gamma^2 - 1) \frac{I}{2} \\ I & 0 \\ 0 & I \end{bmatrix}, H = \begin{bmatrix} I & 0 & 0 & 0 & 0 \\ 0 & 0 & 0 & -I & 0 \\ 0 & 0 & 0 & 0 & I \\ 0 & -I & 0 & 0 & 0 \\ 0 & 0 & I & 0 & 0 \end{bmatrix},$$

then:

$$\Phi(j\omega)^* H \Phi(j\omega) = \begin{bmatrix} G(j\omega) G(j\omega)^* & G(j\omega) - G_r(j\omega) \\ G(j\omega)^* - G_r(j\omega)^* & \gamma^2 I \end{bmatrix}.$$

As a result, (11) is equivalent to:

$$\forall \omega \in (\underline{\omega}, \bar{\omega}), \Phi(j\omega)^* H \Phi(j\omega) > 0. \quad (14)$$

A lemma developed in Rossignol et al. (2001), which is deduced from Loop-shifting, see Desoer and Vidyasagar (1975), and KYP lemma, see Popov and Georgescu (1973), allows us to transform (14) into LMI constraints. This lemma is recalled below:

*Lemma 4.* Consider  $\Psi(\delta) = \delta I \star \begin{bmatrix} A_\psi & B_\psi \\ C_\psi & D_\psi \end{bmatrix}$  and  $H$  (an hermitian matrix), the two following propositions are equivalent:

$$(i) \quad \forall \delta \in (0, +\infty), \Psi(\delta)^* H \Psi(\delta) > 0 \quad (15)$$

(ii) There exists a complex matrix  $P$  such that  $P + P^* < 0$  and:

$$\begin{bmatrix} C_\psi^* \\ D_\psi^* \end{bmatrix} H \begin{bmatrix} C_\psi & D_\psi \end{bmatrix} + \begin{bmatrix} A_\psi^* P^* + P A_\psi & P B_\psi \\ B_\psi^* P^* & 0 \end{bmatrix} > 0 \quad (16)$$

By introducing a finite matrix variable  $P$ , the infinite dimensional constraint on  $\delta$  is transformed into a finite dimensional LMI constraint. However, this lemma can not be directly applied because  $\Phi$  is defined on  $\omega \in (\underline{\omega}, \bar{\omega})$  while  $\Psi$  on  $\delta \in (0, +\infty)$ . In order to apply this lemma, variable substitution must be done to transform  $\Phi(j\omega)$  into  $\Psi(\delta)$ . As  $\Phi$  is computed by  $G$  and  $G_r$ , the objective is to transform  $G(j\omega)|_{\omega \in (\underline{\omega}, \bar{\omega})}$  and  $G_r(j\omega)|_{\omega \in (\underline{\omega}, \bar{\omega})}$  into  $\mathcal{G}(\delta)|_{\delta \in (0, +\infty)}$  and  $\mathcal{G}_r(\delta)|_{\delta \in (0, +\infty)}$ . The transformation can be done through state-space representation.

The state-space representation of  $G(s)$  with  $s$  the Laplace operator can be presented in block diagram as shown in Fig. 1a. Replacing  $s$  by  $j\omega$  and then removing  $j$  from the upper block, we have Fig. 1b. The expression of  $G(j\omega)$  becomes:

$$G(j\omega) = \frac{1}{\omega} I \star \begin{bmatrix} -jA & -jB \\ C & D \end{bmatrix} \quad (17)$$

Variable substitution is done to  $\frac{1}{\omega} I$  by defining  $\frac{1}{\omega} I = \delta I \star T_\Omega$  as shown in Fig. 1c. Then  $G(j\omega)$  becomes:

$$\mathcal{G}(\delta) = \delta I \star \left( T_\Omega \star \begin{bmatrix} -jA & -jB \\ C & D \end{bmatrix} \right) = \delta I \star \begin{bmatrix} A_\delta & B_\delta \\ C_\delta & D_\delta \end{bmatrix}. \quad (18)$$

Fig. 1d shows the block diagram of  $\mathcal{G}(\delta)$ .  $A_\delta$ ,  $B_\delta$ ,  $C_\delta$ , and  $D_\delta$  are complex matrices. Similarly, the reduced model  $G_r(s)$  also has the same form:

$$\mathcal{G}_r(\delta) = \delta I \star \left( T_\Omega \star \begin{bmatrix} -jA_r & -jB_r \\ C_r & D_r \end{bmatrix} \right) = \delta I \star \begin{bmatrix} A_{r\delta} & B_{r\delta} \\ C_{r\delta} & D_{r\delta} \end{bmatrix}. \quad (19)$$

To transform  $\omega \in (\underline{\omega}, \bar{\omega})$  into  $\delta \in (0, +\infty)$ ,  $T_\Omega$  is chosen as:

$$T_\Omega = \left[ \begin{array}{c|c} -\bar{\omega}I & (1 - \frac{\bar{\omega}}{\omega})I \\ \hline I & \frac{1}{\omega}I \end{array} \right], \quad (20)$$

then:

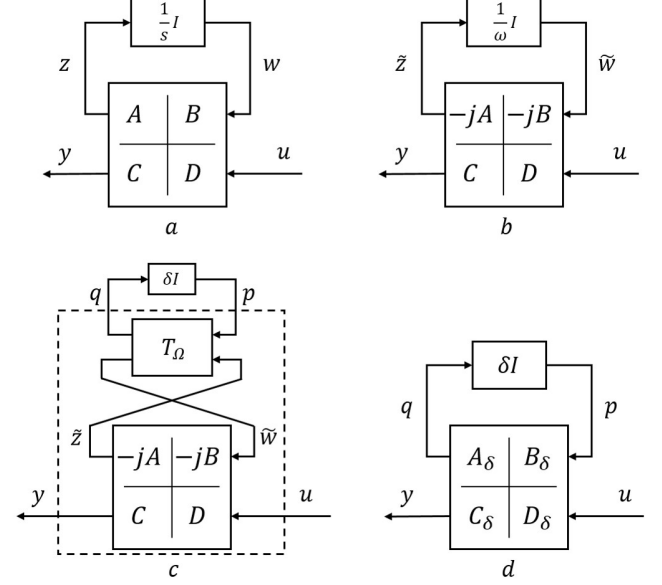

Fig. 1. Block diagram of  $G$  in state-space representation

$$\begin{aligned} \frac{1}{\omega} I &= \delta I \star \left[ \begin{array}{c|c} -\bar{\omega}I & (1 - \frac{\bar{\omega}}{\omega})I \\ \hline I & \frac{1}{\omega}I \end{array} \right] \\ &= \frac{1}{\omega} + \delta(1 + \delta\bar{\omega}I)^{-1}(1 - \frac{\bar{\omega}}{\omega})I \\ &= \frac{1 + \delta\omega}{\omega(1 + \delta\bar{\omega})} I. \end{aligned} \quad (21)$$

$\delta \in (0, +\infty)$  exactly implies  $\omega \in (\underline{\omega}, \bar{\omega})$ . In this way, we transform the system  $G(j\omega)$  and  $G_r(j\omega)$  with  $\omega \in (\underline{\omega}, \bar{\omega})$  into  $\mathcal{G}(\delta)$  and  $\mathcal{G}_r(\delta)$  with  $\delta \in (0, +\infty)$ . By substituting  $T_\Omega$  into (18) and (19), we exactly obtain (10) in Theorem 2.

Taking  $H$  in (12) and defining  $\Psi(\delta)$  as:

$$\Psi(\delta) = \begin{bmatrix} \mathcal{G}(\delta)^* & I \\ 0 & \mathcal{G}_r(\delta) \\ 0 & (\gamma^2 - 1)\frac{I}{2} \\ \hline I & 0 \\ 0 & I \end{bmatrix}, \quad (22)$$

we find equivalence between (14) and (15), and thus equivalence between the constraint in (7) and (15). According to Lemma 4, (15) is equivalent to (16) with  $P + P^* < 0$ . By substituting (22), (18) and (19) into (16), we obtain  $K + K^* > 0$  with  $K$  defined exactly by (9) in Theorem 2.  $\square$

#### 4. APPLICATION ON BEAM-PIEZO SYSTEM

We consider an experimental benchmark which is composed of a thin beam with piezoelectric patches. Two patches are used as actuators and another two as sensors. The objective is to compute a feedback controller that reduces the vibration of the beam under a force disturbance who has high Power Spectrum Density in  $(600, 3200)rad/s$ . In order to know the number of modes to be controlled, a frequency analyzer is used to measure the

frequency response between the actuators and the sensors. The result shows that  $(600, 3200)rad/s$  covers from the 9<sup>th</sup> mode to the 20<sup>th</sup> mode. The initial model is obtained by COMSOL who performs FEM and Modal Displacement Method which gives a model containing the first 20 modes. Then, the model parameters are optimized by identification techniques to make sure that the frequency response of the initial model matches the actual setup. Fig. 2 presents the frequency response of the initial model with order 42. The two vertical lines line out the frequency range of interest. The objective of model reduction is to obtain a reduced-order model which is close to the initial model in  $(600, 3200)rad/s$ , which means neglecting the modes lower than  $600rad/s$ .

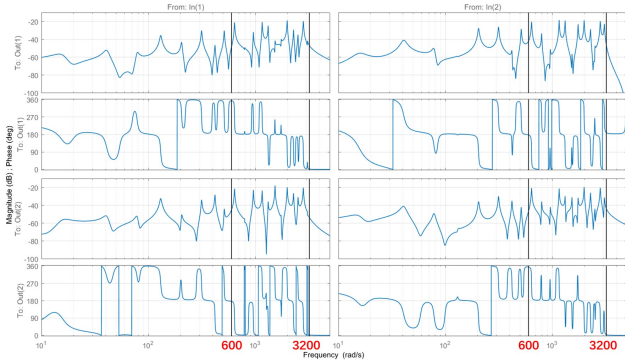

Fig. 2. Frequency response from actuators to sensors, model of the first 20 modes

According to Section 3, MFT is first applied. The initial model is transformed into modal form and the  $2 \times 2$  blocks corresponding to the first 8 modes are truncated. There are also  $1 \times 1$  blocks corresponding to the patches. As their poles are outside  $(600, 3200)rad/s$ , they are also truncated. The order is reduced from 42 to 24. Fig. 3 compares the frequency response of the initial model and the reduced-order model by MFT. The reduced-order model already has good quality except for the response from the 2<sup>nd</sup> input to the 1<sup>st</sup> output at about  $900rad/s$  as marked by red ellipse. This large difference around anti-resonance responses can be clearly seen from the blue line in Fig. 4 where the singular values of  $\Delta(j\omega)$  is presented. At several frequencies,  $\bar{\sigma}(\Delta(j\omega))$  exceeds  $0dB$  and the maximum value is over  $20dB$  at right about  $900rad/s$ . Then, the relative error is minimized by applying Theorem 2 with  $G$  the initial model and  $G_r$  the obtained reduce-order model by MFT. The LMI constrains are programmed in *Matlab* and a solution is computed. The red line in Fig. 4 shows the reduction of the maximum relative error which proves the statement in Remark 1. In fact, the maximum singular values decreases while the minimum singular values increase, which means that LMI balances the errors at different frequencies so that the overall error is reduced. This phenomenon can be also seen in Fig. 5 where the initial model and the reduced-order model after relative error minimization are compared. Thanks to the fact that  $\bar{\sigma}(\Delta(j\omega))$  of the new optimized reduced-order model over  $(600, 3200)rad/s$  is less than 1, it was possible to compute a controller that ensures robust stability by Small Gain Theorem. Indeed, when applied to the full-order model and even to the benchmark, the system is

stable and the vibrations are reduced in the frequency range of interest.

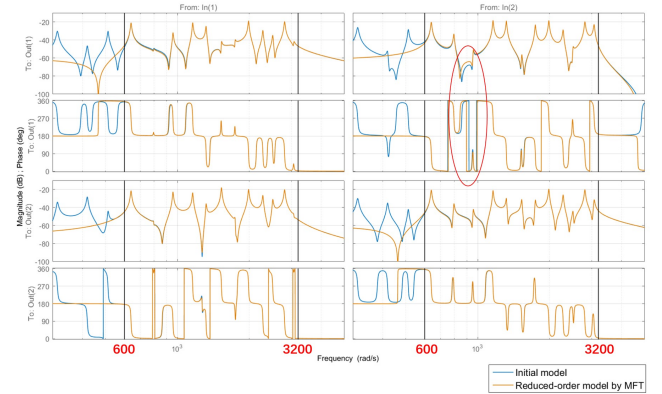

Fig. 3. Frequency response from actuators to sensors: Initial model vs Reduced-order model by MFT

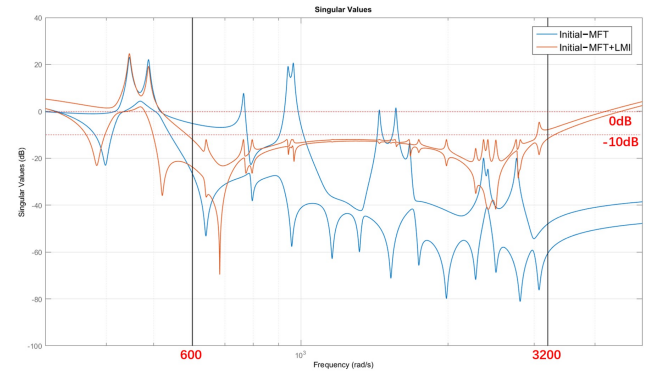

Fig. 4. Singular values of  $\Delta(j\omega)$ : Reduced-order model by MFT vs Reduced-order model by MFT+LMI

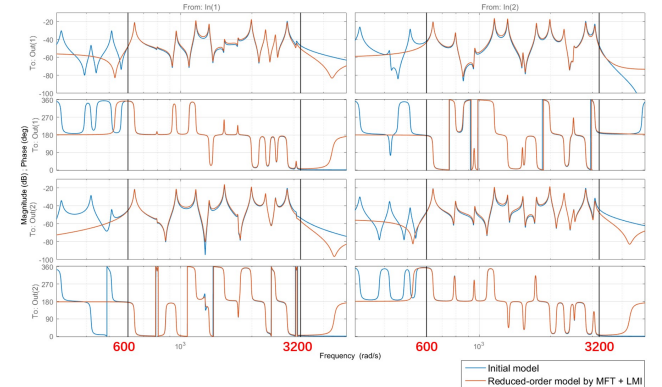

Fig. 5. Frequency response from actuators to sensors: Initial model vs Reduced-order model by MFT+LMI

## 5. CONCLUSION

This paper presents a new model reduction method used for active vibration control of flexible structure. It can be applied on the model obtained by classical model reduction techniques. This method allows us to flexibly choose the modes according to control objective and obtain a further reduced-order model. This is achieved by Pole truncation and relative error minimization. Pole truncation eliminates

the poles outside the frequency range of interest. The order is thus reduced. Relative error minimization optimizes the reduced-order model without changing the poles in order to match the anti-resonance responses. A numerical example demonstrated that this method was effective and a reduce-order model close to the initial model in the frequency range of interest was obtained. By using this reduced-order model, a low-order controller could be computed that ensures the robustness.

## REFERENCES

- Athanasios C Antoulas, Christopher A Beattie, and Serkan Gugercin. Interpolatory model reduction of large-scale dynamical systems. In *Efficient modeling and control of large-scale systems*, pages 3–58. Springer, Boston, MA, 2010.
- Christopher A Beattie and Serkan Gugercin. Model reduction by rational interpolation. *Model Reduction and Algorithms: Theory and Applications*, P. Benner, A. Cohen, M. Ohlberger, and K. Willcox, eds., *Comput. Sci. Engrg.*, 15:297–334, 2014.
- Bart Besselink, U Tabak, A Lutowska, N Van De Wouw, H Nijmeijer, DJ Rixen, ME Hochstenbach, and WHA Schilders. A comparison of model reduction techniques from structural dynamics, numerical mathematics and systems and control. *Journal of Sound and Vibration*, 332(19):4403–4422, 2013.
- Stephen Boyd, Laurent El Ghaoui, Eric Feron, and Venkataramanan Balakrishnan. *Linear matrix inequalities in system and control theory*, volume 15 of *Studies in Applied Mathematics*. SIAM, Philadelphia, PA, jun 1994. ISBN 0-89871-334-X.
- Charles A Desoer and Mathukumalli Vidyasagar. *Feedback systems: input-output properties*, volume 55. SIAM, New York, 1975.
- Matthias Heinkenschloss, Danny C Sorensen, and Kai Sun. Balanced truncation model reduction for a class of descriptor systems with application to the Oseen equations. *SIAM Journal on Scientific Computing*, 30(2):1038–1063, 2008.
- Haw Ling Liew and Peter M Pinsky. Matrix-padé via lanczos solutions for vibrations of fluid–structure interaction. *International Journal for Numerical Methods in Engineering*, 84(10):1183–1204, 2010.
- Vasile Mihai Popov and Radu Georgescu. *Hyperstability of control systems*. Editura Academiei, Springer-Verlag, New York, 1973.
- Laure Rossignol, Gerard Scorletti, and Vincent Fromion. Filter design under magnitude constraints is a finite dimensional convex optimization problem. In *Decision and Control, 2001. Proceedings of the 40th IEEE Conference on*, volume 4, pages 3575–3580. IEEE, 2001.
- Thiago Seuaciuc-Osório and Mohammed F Daqaq. On the reduced-order modeling of energy harvesters. *Journal of Intelligent Material Systems and Structures*, 20(16):2003–2016, 2009.
- Madan G Singh. *Handbook of large scale systems engineering applications*. North Holland, North Holland, 1979.
- Georgios E Stavroulakis, G Foutsitzi, E Hadjigeorgiou, D Marinova, and CC Baniotopoulos. Design and robust optimal control of smart beams with application on vibrations suppression. *Advances in Engineering Software*, 36(11):806–813, 2005.
- Zhuang Wang. Finite element modelling and LQG control of piezoelectric composite structure with distributed sensors and actuators. In *IEEE International Conference on Mechatronics and Automation (ICMA)*, pages 803–808. IEEE, 2016.
- Robert L Williams and Douglas A Lawrence. *Linear state-space control systems*. John Wiley & Sons, Hoboken, New Jersey, 2007.
- Xueji Zhang, ZhongZhe Dong, Martin Hromcik, Kristian Hengster-Movric, Cassio Faria, Herman D Van der Auweraer, and Wim Desmet. Reduced-order robust controller design for vibration reduction. Technical Report 2016-01-1845, SAE Technical Paper, 2016.
- K. Zhou, J.C. Doyle, and K. Glover. *Robust and Optimal Control*. Prentice Hall, New Jersey, 1995.