



**HAL**  
open science

## Power Hardware-In-the-Loop simulation for testing multi-sources vehicles

Ali Castaings, Alain Bouscayrol, Walter Lhomme, Rochdi Trigui

► **To cite this version:**

Ali Castaings, Alain Bouscayrol, Walter Lhomme, Rochdi Trigui. Power Hardware-In-the-Loop simulation for testing multi-sources vehicles. 20th IFAC World Congress, Jul 2017, TOULOUSE, France. pp. 10971-10976, 10.1016/j.ifacol.2017.08.2469 . hal-01745537

**HAL Id: hal-01745537**

**<https://hal.science/hal-01745537v1>**

Submitted on 28 Mar 2018

**HAL** is a multi-disciplinary open access archive for the deposit and dissemination of scientific research documents, whether they are published or not. The documents may come from teaching and research institutions in France or abroad, or from public or private research centers.

L'archive ouverte pluridisciplinaire **HAL**, est destinée au dépôt et à la diffusion de documents scientifiques de niveau recherche, publiés ou non, émanant des établissements d'enseignement et de recherche français ou étrangers, des laboratoires publics ou privés.

# Power Hardware-In-the-Loop simulation for testing multi-sources vehicles

A. Castaings<sup>1,2,3</sup>, A. Bouscayrol<sup>1,3</sup>, W.Lhomme<sup>1,3</sup>, R.Trigui<sup>2,3</sup>

<sup>1</sup>University of Lille1, L2EP, France

<sup>2</sup>IFSTAR, Transport and Environment Laboratory, 69675 Bron, France

<sup>3</sup>MEGEVH, French network on HEVs, megevh.univ-lille1.fr, France

Corresponding author: Alain Bouscayrol

E-mail: [Alain.Bouscayrol@univ-lille1.fr](mailto:Alain.Bouscayrol@univ-lille1.fr)

---

Abstract: Energy management of multi-sources vehicles is a complex task. The higher the number of sources becomes, the higher the complexity is. Moreover, the energy management methods have to face real-time issues. As a consequence, it is important to find some testing procedures to assess the developed methods, in real-time conditions before implementation on the vehicle. In this paper, a Power Hardware-In-The-Loop simulation is implemented for a Fuel Cell – battery – Supercapacitors vehicle. The platform enables to test some Energy Management Strategies in real-time conditions.

**Keywords:** hardware-in-the-loop, energy management, supercapacitor, battery, fuel cell, vehicle

---

## LIST OF ABBREVIATIONS

EMR	Energetic Macroscopic Representation
EMS	Energy Management Strategy
ESS	Energy Storage System
FC	Fuel Cell
H-ESS	Hybrid Energy Storage System
P-HIL	Power Hardware-In-the-Loop
SC	SuperCapacitor
SoC	State of Charge

## I. INTRODUCTION

The urban travel demand is significantly growing. According to the International Energy Agency the 2012 concentration of CO<sub>2</sub> was about 40% higher than in the mid-1800s (IEA, 2013). It is then important to find out alternatives to conventional thermal vehicles.

Several solutions have been depicted such as battery electric vehicles or Fuel Cell (FC) vehicles (Chan et al., 2010). However, each solution has some limitations. FCs have some power transfer issues (Bernard et al., 2009) while batteries have some lifetime issues (Omar et al., 2014). Multi-sources vehicles represent an interesting alternative as they enable to take advantage of the properties of the different sources (Ehsani et al., 2009). However, they represent very complex systems. It is then difficult to manage such systems.

Several works have been done on Energy Management Strategies (EMSs) of multi-sources vehicles. Two approaches have been depicted (Salmasi, 2007; Wirasingha and Emadi, 2011), rule-based approach (García et al., 2013; Thounthong et al., 2009) and optimization-based approach (Yu et al., 2011; Odeim et al., 2016). The main issues are related to real-time applications. Moreover, the EMSs have to ensure the physical limitations (i.e. overcharge or depleting) of the sources for any driving condition. As a consequence, it is important to find

testing procedures to assess the EMSs before their implementation in a real vehicle.

Power Hardware-in-The-Loop (P-HIL) simulation (Bouscayrol, 2011) has been used in several applications for testing components before their implementation in a real system. P-HIL has thus been used for testing EMSs of hybrid and electric vehicles in real-time conditions (Allègre et al., 2013; Castaings et al., 2015; Odeim et al., 2015).

The objective of this paper is to present a P-HIL simulation of a FC-battery-Supercapacitors (SCs) vehicle. The developed platform enables to assess an EMS in real-time conditions (e.g. various driving conditions). The control organization of the P-HIL simulation is achieved by using Energetic Macroscopic Representation (EMR) (Bouscayrol et al., 2012). The second section is devoted to the description of the P-HIL simulation. The control organization is presented in the third section. The results are given in the last section before the conclusion.

## II. P-HIL SIMULATION OF THE STUDIED SYSTEM

### A. P-HIL principle

Hardware-In-the Loop simulation consists in adding some actual elements (hardware) in the simulation loop (Bouscayrol, 2011). In Power HIL, some power elements can be tested before their implementation on the real system. It is useful for testing the subsystem and its control in real-time conditions. (Figure 1.a). In P-HIL simulation, the power part is split into two parts, the part under test (with its control) and the emulated part. An interface (interf. in Figure 1.a) is required for connecting the simulation signals and the power signals. The interface has then power and signals elements. (Figure 1.b). The emulation system must have the same behavior than the simulated system. The control references of the emulation system come from the simulation of the emulated system.

Also, the interface must be faster than the emulated system to emulate without delay.

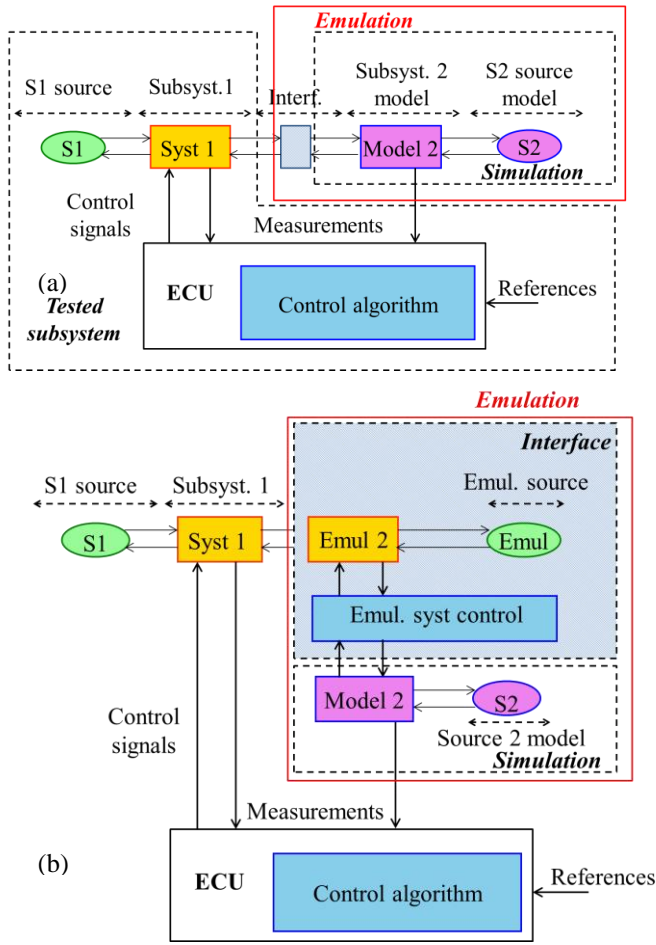

Figure 1: P-HIL, (a) principle, (b) practical scheme

### B. Application to a FC-battery-SCs vehicle

#### Studied system

Several architectures have been used in the literature for FC-battery-SCs associations (Li et al., 2012; Solano-Martinez et al., 2011; Zandi et al., 2011). The architecture of the studied vehicle is presented Figure 2. Each source is interfaced using a DC-DC converter. It enables the decoupling between the DC bus voltage and the different sources (Amjadi and Williamson, 2010).

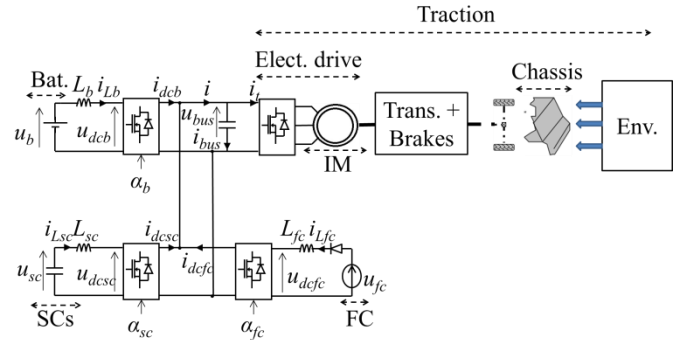

Figure 2: Architecture of the studied vehicle

#### P-HIL organization

The objective of the P-HIL simulation is to assess the system controllability in real-time and to validate the FC and SCs behavior. In the presented work, the emulated parts are the battery branch and the traction part. The corresponding emulation systems are depicted Figure 3. For the battery branch, the battery is replaced by a SCs bank. The SCs bank has to reflect two battery characteristics

- the battery SoC limitations : this depends on the SCs bank size
- the battery voltage dynamics. The SCs voltage has higher dynamics than the battery voltage ones. If the battery model is accurate enough, the battery voltage dynamics can be reflected by the SCs.

The traction part is emulated by a current source composed of a DC-DC converter, a smoothing inductor and a SCs bank. The main dynamics of the inverter current are taken into account in the traction model (cf. section III).

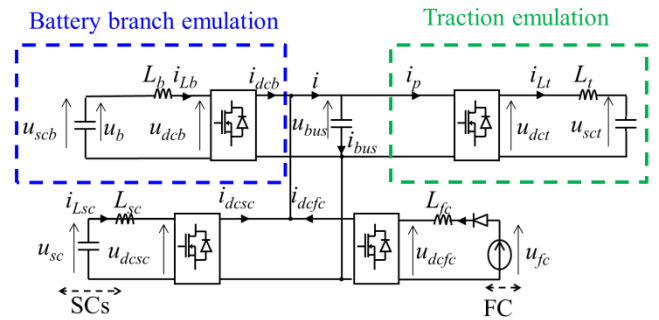

Figure 3: P-HIL system architecture

The next part is devoted to the control organization of the P-HIL system. Different parts have to be interconnected. Indeed, there are the models simulations, the emulation subsystems with their control, the tested subsystems and their control. A graphical formalism, Energetic Macroscopic Representation (EMR) is used as a tool for achieving the subsystems interconnection. First, EMR is based on action-reaction principle. It enables to ensure a physical connection between the elements. Second, EMR approach is based on causality principle. It enables to deduce the control structure of the

system and to use real-time models for the emulation subsystems.

### III. CONTROL ORGANIZATION

#### A. Real part

The control of the system is achieved by using Energetic Macroscopic Representation (EMR). EMR highlights energetic properties of the components of a system to develop control schemes (Bouscayrol et al., 2012). There are several pictograms to represent the system model (see Appendix). By using EMR approach, the control part is organized in two levels, the “local control” part and the “global control” part (i.e. EMS). The main interest of using EMR is that the “local control” part of the system can be systematically deduced by “mirror” effect from its EMR. The EMR and the control part of the “real part” of the system are depicted Figure 4.

#### Local control part

The local control is represented by the light blue blocks in Figure 4. It manages the system components to track the reference of the DC bus voltage. The right duty cycles of the converters ( $\alpha_b$ ,  $\alpha_{fc}$  and  $\alpha_{sc}$ ) are then defined. In addition, the local control points out the control requirements. In the studied case 4 sensors and 4 controllers (closed-loop control) are required as well. The inversion of an accumulation element is performed via a closed-loop control (crossed blue parallelogram). A conversion element is directly inverted with an open-loop control (blue parallelogram). The inversion of a coupling element depicts degrees of freedom that correspond to the output of the EMS (global control).

#### Global control part

The global control part corresponds to the Energy Management Strategy (EMS). That aims to use the degrees of freedom of the control in the best way. There are two kinds of EMSs for multi-sources vehicles; rule-based EMSs and optimization-based EMSs (Salmasi, 2007)

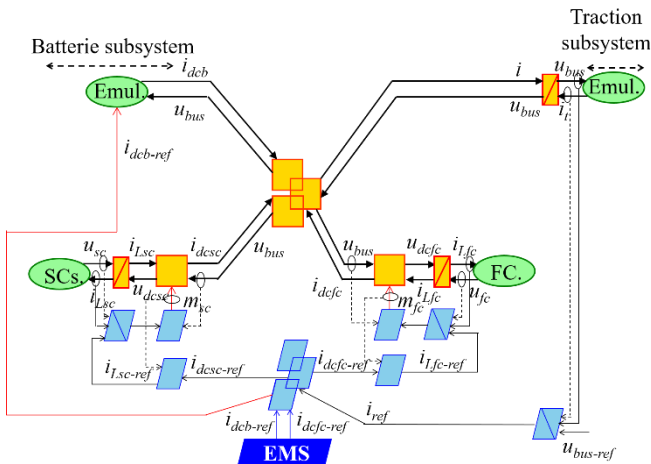

Figure 4: EMR and control organization of the “real part”

#### B. Emulated parts

The EMR and its control organization of the emulated parts are depicted Figure 5. The purple blocks correspond to the simulated part of the P-HIL simulation. As it can be noticed, the control references come from the simulation of the real components models (purple pictograms). Also this is a reduced-scale P-HIL simulation. As a result, some adaption coefficients are taken into account (Allègre et al., 2013). These coefficients enable to pass from the full-scale simulated models to the reference signals of the reduced-scale system (1). The reduced-scale coefficients values are given in Table 1.

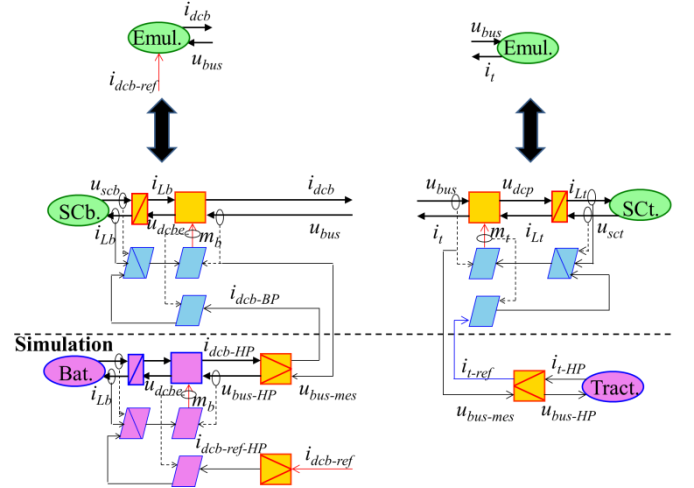

Figure 5: EMR and control organization of the emulated parts

$$\begin{cases} i_{dcb-BP} = \frac{i_{dcb-HP}}{k_{i-sbat}} \\ i_{dcb-ref-HP} = i_{dcb-ref} k_{i-sbat} \\ u_{bus-HP} = k_{u-sbat} u_{bus-mes} \\ i_{t-ref} = \frac{i_{t-HP}}{k_{i-tract}} \end{cases} \quad (1)$$

### IV. VALIDATION OF AN ENERGY MANAGEMENT STRATEGY

#### A. Principle

The experimental setup is presented Figure 6. A dSPACE 1005 card is used as an interface between the power part and the computer board. The EMS is an optimization-based strategy. It consists in minimizing the hydrogen consumption while improving the battery lifetime (Castaings et al., 2016). The first test is achieved on a standard driving cycle (WLTC class 2, low velocity phase Figure 7) where the EMS parameters have been identified. This corresponds to “ideal” driving conditions. The second test is carried out using a real driving cycle (Figure 8) coming from results on the instrumented car (Tazzari Zero) (Depature et al., 2014). This test enables to assess the robustness of the EMS when varying the driving conditions. The parameters of the full scale and reduced scale systems are given in Table 1.

Table 1: Full scale and reduced scale systems parameters

	Full-scale system	Reduced-scale system
<b>FC stack</b>	Type: PEMFC Max power: 20 kW Voltage range: 50-80 V Max current : 360 A	Type: PEMFC Max power: 1.2 kW Voltage range: 28-43 V Max current: 45 A
<b>Vehicle</b>	640 kg	$k_{i-tract}=1/17$
<b>Electric drive</b>	Rated voltage: 80 V Rated power : 15 kW	Rated voltage: 80 V Rated power : 882 W
<b>Smoothing inductors</b>	SCs : $r_{Lsc}=10\text{m}\Omega$   $L_{sc}=200\mu\text{H}$ FC: $r_{Lfc}=10\text{m}\Omega$   $L_{fc}=200\mu\text{H}$ Battery : $r_{Lb}=10\text{m}\Omega$   $L_b=200\mu\text{H}$	SCs : $r_{Lsc}=260\text{m}\Omega$   $L_{sc}=861\mu\text{H}$ FC: $r_{Lfc}=200\text{m}\Omega$   $L_{fc}=839\mu\text{H}$ Battery : $r_{Lb}=100\text{m}\Omega$   $L_b=882\mu\text{H}$
<b>SCs bank</b>	45 V   $R_{sc}=3.8\text{m}\Omega$   $C_{sc}=290\text{F}$ $u_{sc-M}=45\text{V}$   $u_{sc-m}=0.65u_{sc-M}$ $u_{SC-0}=0.9u_{sc-M}$	45 V   $R_{sc}=57\text{m}\Omega$   $C_{sc}=19\text{F}$ $u_{sc-M}=44\text{V}$   $u_{sc-m}=0.65u_{sc-M}$ $u_{SC-0}=0.9u_{sc-M}$
<b>Battery</b>	24 cells (3.3 V / 20 Ah / 820 W) $SoC_{b-M}=100\%$   $SoC_{b-m}=90\%$ $SoC_{b-0}=95\%$	$k_{i-sbat}=1/17$ $k_{u-sbat}=1$

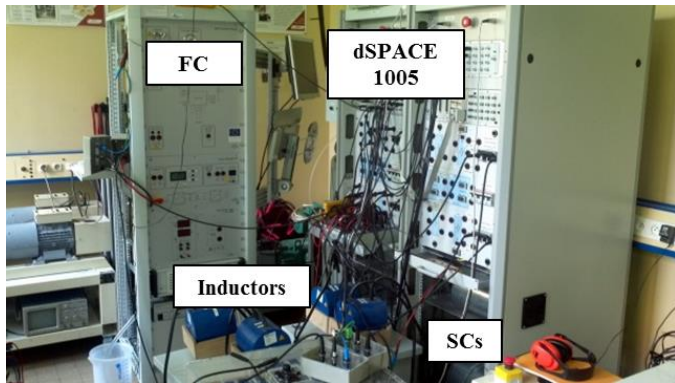

Figure 6: Experimental setup

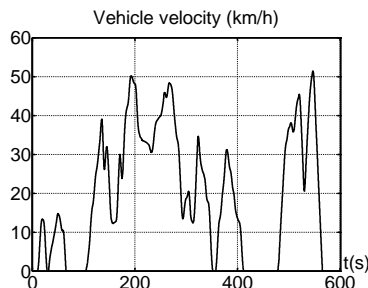

Figure 7: standard driving cycle

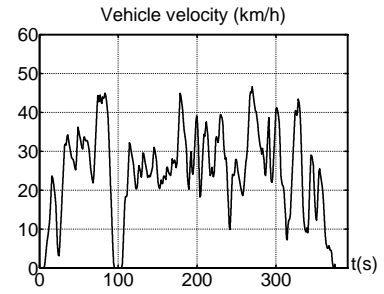

Figure 8: real driving cycle

### B. Standard driving cycle

Some experimental results on the standard driving cycle are given next. The EMS enables to reduce the FC current peaks. This is interesting for its lifetime (Figure 9). As depicted in Figure 10 the EMS enables to respect the SCs voltage limitations. This is important for ensuring the system safety. This aspect has been assessed thanks to the P-HIL platform.

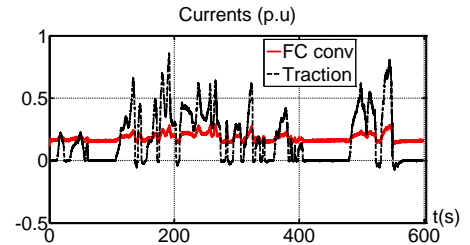

Figure 9: FC branch and traction currents

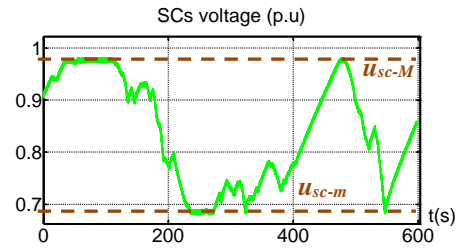

Figure 10: SCs voltage

### C. Real driving cycle

The same trends can be noticed for the real driving cycle (Figure 11 and Figure 12). The key point is that the EMS still enables to reach interesting performances while ensuring the system safety. However, as the parameters were not computed on this driving cycle, the SCs tend to be discharged at the end of the driving cycle. This can cause some repeatability issues. Indeed, if the same driving cycle is repeated, the results won't be the same as the previous one.



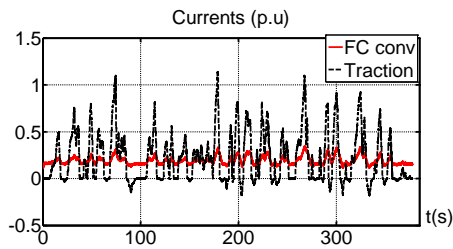

Figure 11: FC branch and traction currents

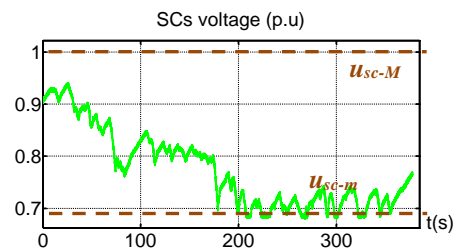

Figure 12: SCs voltage

## V. CONCLUSION

A Power Hardware-In-the-Loop Simulation has been developed for a Fuel Cell – battery – Supercapacitors vehicle. The traction part of the vehicle has been emulated by a current source. The developed platform has enabled to test an Energy Management Strategy in real-time conditions. According to the results, the EMS proves to be effective for real-time applications. In future, the P-HIL platform could be improved by using an electric machine for the traction part.

## REFERENCES

Allègre, A.-L., Bouscayrol, A., Trigui, R., 2013. Flexible real-time control of a hybrid energy storage system for electric vehicles. *IET Electr. Syst. Transp.* 3, 79–85. doi:10.1049/iet-est.2012.0051

Amjadi, Z., Williamson, S.S., 2010. Power-Electronics-Based Solutions for Plug-in Hybrid Electric Vehicle Energy Storage and Management Systems. *IEEE Trans. Ind. Electron.* 57, 608–616. doi:10.1109/TIE.2009.2032195

Bernard, J., Delprat, S., Buchi, F.N., Guerra, T.-M., 2009. Fuel-Cell Hybrid Powertrain: Toward Minimization of Hydrogen Consumption. *IEEE Trans. Veh. Technol.* 58, 3168–3176. doi:10.1109/TVT.2009.2014684

Bouscayrol, A., 2011. Hardware-in-the-loop simulation, in: *Control and Mechatronics*. CRC Press, Taylor & Francis group, Chicago.

Bouscayrol, A., Hautier, J.-P., Lemaire-Semail, B., 2012. Graphic Formalisms for the Control of Multi-Physical Energetic Systems, in: *Systemic Design Methodologies for Electrical Energy Systems: Analysis, Synthesis and Management*. John Wiley & Sons.

Castaings, A., Lhomme, W., Trigui, R., Bouscayrol, A., 2016. Comparison of energy management strategies of a battery/supercapacitors system

for electric vehicle under real-time constraints. *Appl. Energy* 163, 190–200. doi:10.1016/j.apenergy.2015.11.020

Castaings, A., Lhomme, W., Trigui, R., Bouscayrol, A., 2015. Practical control schemes of a battery/supercapacitor system for electric vehicle. *IET Electr. Syst. Transp.* 6, 20–26. doi:10.1049/iet-est.2015.0011

Chan, C.C., Bouscayrol, A., Chen, K., 2010. Electric, Hybrid, and Fuel-Cell Vehicles: Architectures and Modeling. *IEEE Trans. Veh. Technol.* 59, 589–598. doi:10.1109/TVT.2009.2033605

Depature, C., Lhomme, W., Bouscayrol, A., Sicard, P., Boulon, L., 2014. Efficiency Map of the Traction System of an Electric Vehicle from an On-Road Test Drive, in: *2014 IEEE Vehicle Power and Propulsion Conference (VPPC)*. Presented at the 2014 IEEE Vehicle Power and Propulsion Conference (VPPC), pp. 1–6. doi:10.1109/VPPC.2014.7007056

Ehsani, M., Gao, Y., Emadi, A., 2009. *Modern Electric, Hybrid Electric, and Fuel Cell Vehicles: Fundamentals, Theory, and Design*, Second Edition. CRC Press.

García, P., Fernández, L.M., Torreglosa, J.P., Jurado, F., 2013. Operation mode control of a hybrid power system based on fuel cell/battery/ultracapacitor for an electric tramway. *Comput. Electr. Eng.* 39, 1993–2004. doi:10.1016/j.compeleceng.2013.04.022

IEA, 2013. *CO2 Emissions from Fuel Combustion, Highlights*.

Li, Q., Chen, W., Li, Y., Liu, S., Huang, J., 2012. Energy management strategy for fuel cell/battery/ultracapacitor hybrid vehicle based on fuzzy logic. *Int. J. Electr. Power Energy Syst.* 43, 514–525. doi:10.1016/j.ijepes.2012.06.026

Odeim, F., Roes, J., Heinzl, A., 2016. Power Management Optimization of a Fuel Cell/Battery/Supercapacitor Hybrid System for Transit Bus Applications. *IEEE Trans. Veh. Technol.* 65, 5783–5788. doi:10.1109/TVT.2015.2456232

Odeim, F., Roes, J., Heinzl, A., 2015. Power Management Optimization of an Experimental Fuel Cell/Battery/Supercapacitor Hybrid System. *Energies* 8, 6302–6327. doi:10.3390/en8076302

Omar, N., Monem, M.A., Firouz, Y., Salminen, J., Smekens, J., Hegazy, O., Gaulous, H., Mulder, G., Van den Bossche, P., Coosemans, T., Van Mierlo, J., 2014. Lithium iron phosphate based battery – Assessment of the aging parameters and development of cycle life model. *Appl. Energy* 113, 1575–1585. doi:10.1016/j.apenergy.2013.09.003

Salmasi, F.R., 2007. Control Strategies for Hybrid Electric Vehicles: Evolution, Classification, Comparison, and Future Trends. *IEEE Trans. Veh. Technol.* 56, 2393–2404. doi:10.1109/TVT.2007.899933



Solano-Martinez, J., Hissel, D., Pera, M.-C., Amiet, M., 2011. Practical Control Structure and Energy Management of a Testbed Hybrid Electric Vehicle. *IEEE Trans. Veh. Technol.* 60, 4139–4152. doi:10.1109/TVT.2011.2169821

Thounthong, P., Raël, S., Davat, B., 2009. Energy management of fuel cell/battery/supercapacitor hybrid power source for vehicle applications. *J. Power Sources, Scientific Advances in Fuel Cell Systems* 193, 376–385. doi:10.1016/j.jpowsour.2008.12.120

Wirasingha, S.G., Emadi, A., 2011. Classification and Review of Control Strategies for Plug-In Hybrid Electric Vehicles. *IEEE Trans. Veh. Technol.* 60, 111–122. doi:10.1109/TVT.2010.2090178

Yu, Z., Zinger, D., Bose, A., 2011. An innovative optimal power allocation strategy for fuel cell, battery and supercapacitor hybrid electric vehicle. *J. Power Sources* 196, 2351–2359. doi:10.1016/j.jpowsour.2010.09.057

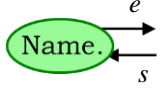
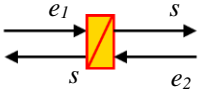
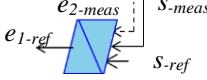
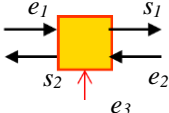
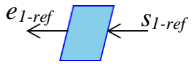
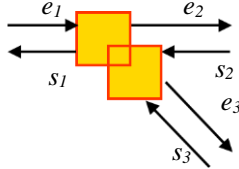
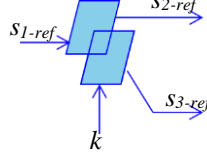
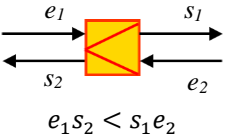
Zandi, M., Payman, A., Martin, J.-P., Pierfederici, S., Davat, B., Meibody-Tabar, F., 2011. Energy Management of a Fuel Cell/Supercapacitor/Battery Power Source for Electric Vehicular Applications. *IEEE Trans. Veh. Technol.* 60, 433–443. doi:10.1109/TVT.2010.2091433

	<p>Action and reaction variables</p> $P = e_1 e_2$		<p>Energy source</p>
	<p>Accumulation element (energy storage)</p>		<p>Indirect inversion (closed-loop control)</p>
	<p>Mono-domain conversion element</p>		<p>Direct inversion (open-loop control)</p>
	<p>Mono-domain coupling element (energy distribution)</p>		<p>Coupling inversion (energy criteria)</p>
	<p>Power adaption</p>		<p>Energy Management Strategy</p>