



HAL
open science

On the Energy Efficiency of Virtual MIMO Systems

Vineeth Varma, Salah Eddine Elayoubi, Mérouane Debbah, Samson Lasaulce

► **To cite this version:**

Vineeth Varma, Salah Eddine Elayoubi, Mérouane Debbah, Samson Lasaulce. On the Energy Efficiency of Virtual MIMO Systems. IEEE International Symposium on Personal, Indoor and Mobile Radio Communications, Sep 2013, Cannes, France. hal-01745104

HAL Id: hal-01745104

<https://hal.science/hal-01745104v1>

Submitted on 27 Mar 2018

HAL is a multi-disciplinary open access archive for the deposit and dissemination of scientific research documents, whether they are published or not. The documents may come from teaching and research institutions in France or abroad, or from public or private research centers.

L'archive ouverte pluridisciplinaire **HAL**, est destinée au dépôt et à la diffusion de documents scientifiques de niveau recherche, publiés ou non, émanant des établissements d'enseignement et de recherche français ou étrangers, des laboratoires publics ou privés.

On the Energy Efficiency of Virtual MIMO Systems

Vineeth S Varma^{1,2}, Salah Eddine Elayoubi¹, Merouane Debbah⁴ and Samson Lasaulce²

¹Orange Labs
92130 Issy Les Moulineaux
France
salaheddine.elayoubi@orange.com

²LSS, SUPELEC
91192 Gif sur Yvette
France
Vineeth.varma@lss.supelec.fr
Samson.lasaulce@lss.supelec.fr

⁴Alcatel Lucent Chair
SUPELEC
91192 Gif sur Yvette
France
Merouane.debbah@supelec.fr

Abstract—The major motivation behind this work is to optimize the sleep mode and transmit power level strategies in a small cell cluster in order to maximize the proposed energy efficiency metric. We study the virtual multiple input multiple output (MIMO) established with each base station in the cluster equipped with one transmit antenna and every user equipped with one receive antennas each. The downlink energy efficiency is analyzed taking into account the transmit power level as well as the implementation of sleep mode schemes. In our extensive simulations, we analyze and evaluate the performance of the virtual MIMO through zero-forcing schemes and the benefits of sleep mode schemes in small cell clusters. Our results show that for certain configurations of the system, implementing a virtual MIMO with several transmit antennas can be less energy efficient than a system with sleep mode using OFDMA with a single transmitting antenna for serving multiple users.

I. INTRODUCTION

The energy consumed by the radio access network infrastructure is becoming a central issue for operators [1]. The goal of this work is to provide insights on how to design green radio access networks, especially in the framework of virtual MIMO systems. Indeed, classical network architectures are focused on integrated, macro base stations, where each cell covers a pre-determined area, and inter-cell interference is reduced by the means of fixed frequency reuse patterns [2]. Heterogeneous Networks (HetNets) introduced a new notion of small cells where pico or femto base stations are deployed within the coverage area of the macro base stations [3]. Virtual MIMO is a step forward in this context that allows distributed systems of base stations/antennas that cover a common area and cooperate in order to increase the overall spectral efficiency [4]. This paper focuses on these latter solutions and aims at addressing the problem from an energy efficiency point of view.

For classical macro networks, early works focused on designing energy-efficient power control mechanisms [5]. Therein, the authors define the energy-efficiency of a communication as the ratio of the net data rate (called goodput) to the radiated power; the corresponding quantity is a measure of the average number of bits successfully received per joule consumed at the transmitter. This metric has been used in many works. Although fully relevant, the performance metric introduced in [5] ignored the fact that transmitters consume a constant energy regardless of their output power level [6]. The impact of this constant energy has been studied for single user point-to-point MIMO systems in [7]. Sleep mode mechanisms have thus been regarded as a solution for this issue; they

consist in deactivating network resources that have low traffic load, eliminating thus both the variable and constant parts of the energy consumption [1]. This mechanism has been applied to macro networks [1], as well as to heterogeneous networks with macro and small cells [3]. Our aim in this paper is to extend this concept to virtual MIMO networks, where an antenna that is not significantly contributing to the network capacity (for a given configuration of user positions and radio channels) is put into sleep mode.

The remainder of this paper is organized as follows. In section II, we present the system model and the resource allocation scheme. Section III presents our energy efficiency metric and optimizes it for a given system and channel configuration, using sleep mode mechanisms. Section IV presents some numerical examples and section V eventually concludes the paper.

II. SYSTEM MODEL

The wireless system under consideration is the downlink in a virtual MIMO system within a small cell cluster. To be precise, each of the small cell base stations are connected to a central processor and so they act as antennas for the virtual MIMO as shown in Fig 1. We refer to the set of these base

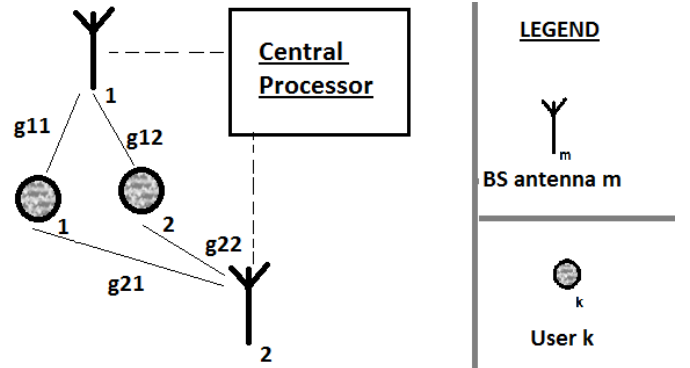

Fig. 1. An example illustration of a 2×2 virtual MIMO with $g_{i,j}$ representing the channel between BS antenna i and user j .

stations as the "cluster". Each user is equipped with a single receive antenna. In order to eliminate interference zero-forcing is implemented. We consider a block-fading channel model where the channel fading stays is assumed to stay constant for the duration of the block and changes from block to block. The base stations require the channel state information available at

the user end in order to implement the zero-forcing technique. Therefore, in each block channel a training and feedback mechanism happens, after which data is transmitted. We also assume that every base station is capable of entering into a "sleep-mode". In this mode, the base station does not send any pilot signals and therefore does not perform the training or feedback actions consuming a lesser quantity of power compared to the active base stations. Let there be M base stations in the cluster and K users. Define $\mathcal{K} = \{1, 2, \dots, K\}$ and $\mathcal{M} = \{1, 2, \dots, M\}$ the sets of users and base station antennas.

A. Power consumption model

As the transmit antennas are not co-located, each of them have an individual power budget. When a base station is active, it consumes a constant power of b due to the power amplifier design and training or feedback costs. Additionally, it consumes a power $P_m \|x_m\|^2$ proportional to the radiated power, where $P_m \leq P_{\max}$ and $\|x_m\| \leq 1$ is the signal transmitted and P_{\max} is the power constraint [1][6]. When it is placed on sleep mode, it is assumed that it only consumes power c where $c < b$. Denote by \mathbf{s} the sleep mode state vector of the cluster with elements $s_m \in \{0, 1\}$. The base station m is in sleep mode when $s_m = 1$ and active when $s_m = 0$. Thus the power consumption of the m -th base station is $cs_m + (1 - s_m)(b + P_m \|x_m\|^2)$. The total power consumption of the cluster is given by:

$$P_{\text{tot}} = \sum_{m=1}^M cs_m + (1 - s_m)(b + P_m \|x_m\|^2) \quad (1)$$

For any given state of the cluster, we define $\omega(\mathbf{s})$ as the total number of base stations that are active. This value can be calculated as $\omega(\mathbf{s}) = M - \sum_m s_m$. If $M < K$, zero-forcing can not be used. However, if $M > K$, and $\omega(\mathbf{s}) \geq K$, then the zero-forcing technique can be implemented by choosing K base stations to transmit the data signals after all $\omega(\mathbf{s})$ active base stations train and obtain feedback on their channels.

B. The zero-forcing scheme

As there are K users connected to the $\omega(\mathbf{s})$ active base stations, there are a total of $\omega(\mathbf{s}) \times K$ number of channels. Let $\zeta = \{1, 2, \dots, \omega(\mathbf{s})\}$ be the set of active base stations. We denote by \mathbf{G} with elements $g_{l,k} \in \mathbb{R}$ the path fading between base station $l \in \zeta$ and user $k \in \mathcal{K}$, while $\tilde{\mathbf{H}}$ with elements $\tilde{h}_{l,k} \in \mathbb{C}$ denotes the fast fading component, resulting in a signal at k given by:

$$y_k = \sum_{l=1}^{\omega(\mathbf{s})} \sqrt{\frac{g_{l,k} P_l}{\sigma^2}} \tilde{h}_{l,k} x_l + z \quad (2)$$

where \mathbf{x} is the signal transmitted with x_l as its elements; z is the normalized noise and σ^2 the noise strength. Note that $g_{l,k}$ can be determined based on the user location while $\tilde{h}_{l,k}$ are i.i.d. zero-mean unit-variance complex Gaussian random variables. We define $\tilde{\mathbf{H}}(\mathbf{G}, \tilde{\mathbf{H}})$ as the combined channel matrix with elements $\tilde{h}_{l,k} = \sqrt{g_{l,k}} \tilde{h}_{l,k}$.

In our work, as we focus on the small-cell scenario where the antennas are distributed over the cell in a dense manner, we assume that every user can have a similar level of signal strength. Define $\mathcal{N} = \{1, 2, \dots, N\}$ as the set of transmitting antennas that perform zero forcing beam-forming. We define $\beta \in \mathcal{N} \rightarrow \zeta$ as the function that describes which base stations in ζ will be picked to transmit the data signals. Given BS $j \in \mathcal{N}$, the corresponding label for the BS in ζ is given by $\beta(j)$. Given $\omega(\mathbf{s})$ active base stations that perform training and receive feedback on $\tilde{\mathbf{H}}$, we define the effective channel matrix as $\mathbf{H}(\tilde{\mathbf{H}}, \beta)$, where its elements $h_{j,k} = \tilde{h}_{\beta(j),k}$. For zero-forcing, we require that the number of transmitting antennas is equal to the number of receiving antennas or $K = N$. With this constraint, if \mathbf{H} is an invertible matrix, we define:

$$\bar{\mathbf{x}} = (\mathbf{H}(\tilde{\mathbf{H}}, \beta))^{-1} \mathbf{u} \quad (3)$$

where \mathbf{u} is a vector of length K , where u_k which is the signal received by the k -th user. In this work, we take $\|u_k\|^2 = 1$ so that each user obtains identical signal strengths. This constraint has several benefits:

- 1) This results in a very "fair" beam forming scheme as all users experience equal signal strength and thus similar data rates.
- 2) As the base station antennas are spread over the cell, there is no user on the "cell edge" or "cell center". In this situation, equal SINRs for all users can result in less congestion when user traffic patterns are taken into account
- 3) Finally, the resulting system is far less complex and easier to analyze than one with arbitrary values for $\|u_k\|^2$.

With these definitions, we can now precode the transmitted signal as:

$$\mathbf{x} = \frac{\bar{\mathbf{x}}}{\alpha(\tilde{\mathbf{H}}, \beta)} \quad (4)$$

where $\alpha(\tilde{\mathbf{H}}, \beta) = \max(\bar{x}_m)$. This pre-coding works only if all the P_j are equal, and so we chose $P_j = P_0$. From this point onwards, P_0 represents the transmit power level of the system with this pre-coding. The signal received by each of the K users is given by:

$$y_k = \sqrt{\frac{P_0}{\sigma^2}} \frac{u_k}{\alpha(\tilde{\mathbf{H}}, \beta)} + z \quad (5)$$

Thus the SINR at each user is now given by

$$\gamma_k = \frac{P_0}{\|\alpha(\tilde{\mathbf{H}}, \beta)\|^2 \sigma^2} \quad (6)$$

III. ENERGY EFFICIENCY OPTIMIZATION

This work aims at minimizing the energy consumption by base stations. If each user in the network is connected to download some data, then the total energy consumed by the network is the total power consumed multiplied by the total duration for which the user stays connected. Energy efficiency (EE) is a metric that is often used to measure this, and maximizing the energy efficiency leads to minimizing the total energy consumed.

A. Defining the EE metric

Before defining the EE, we first calculate the total power consumption of the network. From (1) and (4), the total power consumed is given by:

$$P_{tot}(P_0, \tilde{\mathbf{H}}, \beta) = \sum_{m=1}^M cs_m + (1 - s_m) \times \left(b + P_0 \left\| \frac{(\mathbf{H}^{-1}(\tilde{\mathbf{H}}, \beta) \mathbf{u})_{\beta^{-1}(m)}}{\alpha(\tilde{\mathbf{H}}, \beta)} \right\|^2 \right) \quad (7)$$

Here we define

$$\forall m \in \mathcal{M}; \beta^{-1}(m) = \begin{cases} j & \text{if } j \in \mathcal{N} \text{ exists s.t } \beta(j) = m \\ 0 & \text{otherwise.} \end{cases} \quad (8)$$

and $()_j$ is the j -th element if $j \neq 0$ and is 0 if $j = 0$. In this scenario, we define the instantaneous energy efficiency as:

$$\eta(P_0, \tilde{\mathbf{H}}, \beta) = \frac{\sum_k f(\gamma_k(P_0, \tilde{\mathbf{H}}, \beta))}{P_{tot}(P_0, \tilde{\mathbf{H}}, \beta)} \quad (9)$$

where $f()$ gives the effective throughput as a function of the SINR. $f(\gamma_k) = \log(1 + \gamma_k)$ for example. However when we study the base station energy efficiency for a longer duration, the effects of fast fading in $\tilde{\mathbf{H}}$ gets averaged and in this case a more reasonable definition for the EE is:

$$\bar{\eta}(P_0, \mathbf{G}, \beta) = \frac{\mathbb{E}_{\tilde{\mathbf{H}}}[\sum_k f(\gamma_k(P_0, \tilde{\mathbf{H}}(\mathbf{G}, \tilde{\mathbf{H}}), \beta))]}{\mathbb{E}_{\tilde{\mathbf{H}}}[P_{tot}(P_0, \tilde{\mathbf{H}}(\mathbf{G}, \tilde{\mathbf{H}}), \beta)]} \quad (10)$$

B. Optimization w.r.t the transmit power

In this section, we show some properties of our energy efficiency metric w.r.t P_0 . If the goal of a system is to be energy efficient using power control, then one important question arises: Is there a unique power for which the energy efficiency is maximized? We answer this question with the following proposition:

Proposition 1: Given a certain path loss matrix \mathbf{G} and a selection of transmitting base stations β in the virtual MIMO system, the average EE $\bar{\eta}(P_0, \mathbf{G}, \beta)$ is maximized for a unique P_0^* and is quasi-concave in P_0 .

Proof: Consider the SINR for each user γ_k . It can be observed that $\frac{\partial \gamma_k(P_0, \tilde{\mathbf{H}}, \beta)}{\partial P_0}$ is a constant. So if $f()$ is concave in γ_k , it is also concave in P_0 . Now consider the numerator of (10), $\mathbb{E}_{\tilde{\mathbf{H}}}[\sum_k f(\gamma_k(P_0, \tilde{\mathbf{H}}(\mathbf{G}, \tilde{\mathbf{H}}), \beta))]$. This is a weighted sum of several concave functions and is hence also concave itself. Similarly, $\frac{\partial P_{tot}(P_0, \tilde{\mathbf{H}}, \beta)}{\partial P_0}$ can also be verified to be a constant. Hence, $\frac{\partial \mathbb{E}_{\tilde{\mathbf{H}}}[P_{tot}(P_0, \tilde{\mathbf{H}}, \beta)]}{\partial P_0}$ is a constant. Thus $\bar{\eta}(P_0, \mathbf{G}, \beta)$ is the ratio of a concave function of P_0 to a linear function of P_0 . This is known to be quasi-concave and has a unique maximum P_0^* satisfying:

$$\frac{\partial \bar{\eta}(P_0^*, \mathbf{G}, \beta)}{\partial P_0} = 0 \quad (11)$$

■

This proposition guarantees that given a certain choice of transmit antennas and a path fading matrix, the energy efficiency can always be optimized w.r.t the transmit power level P_0 .

C. Optimizing the selection of transmitting base stations

Given a certain sleep mode state \mathbf{s} , there are $\omega(\mathbf{s})$ base stations active that train and obtain feedback. From this set ζ , K base stations have to be picked for zero-forcing. This choice is mathematically expressed by β . The β that optimizes the energy efficiency depends on the channel state $\tilde{\mathbf{H}}$. The following proposition details the method of choosing the β that optimizes EE.

Proposition 2: When $\frac{P_0}{b} \rightarrow 0$, the β^* that maximizes $\bar{\eta}(P_0, \mathbf{G}, \beta)$ is obtained by:

$$\beta^* = \arg \min[\alpha(\tilde{\mathbf{H}}, \beta); \beta \in \{\mathcal{N} \rightarrow \mathcal{K}\}] \quad (12)$$

Proof: By observing (6) it can be seen that $\gamma_k(P_0, \tilde{\mathbf{H}}, \beta)$ is maximized by picking β^* . And so $\sum_k f(\gamma_k(P_0, \tilde{\mathbf{H}}, \beta))$ is maximized when $\beta = \beta^*$. When $\frac{P_0}{b} \rightarrow 0$, for β^* and any β_1 we have:

$$\lim_{\frac{P_0}{b} \rightarrow 0} \bar{\eta}(P_0, \mathbf{G}, \beta^*) - \bar{\eta}(P_0, \mathbf{G}, \beta_1) = \quad (13)$$

$$\frac{\mathbb{E}_{\tilde{\mathbf{H}}}[\sum_k f(\gamma_k(P_0, \tilde{\mathbf{H}}, \beta^*)) - \sum_k f(\gamma_k(P_0, \tilde{\mathbf{H}}, \beta_1))]}{\sum_{m=1}^M cs_m + (1 - s_m)b} \geq 0 \quad (14)$$

■

This implies that we pick β such that $\alpha(\tilde{\mathbf{H}}, \beta)$ is minimized for optimizing EE when $b \gg P_0$. From a practical point of view, the above result is useful as it proposes an algorithm to pick the right base stations based on the CSI obtained from all the base stations that are active. The condition $b \gg P_0$ is most applicable when the users are close to the base stations resulting in a low P_0 being used for maximizing EE.

IV. NUMERICAL RESULTS

In this section we use simulations and numerical calculations to study the effectiveness of our proposal as well as the advantages offered. For the purpose of a thorough numerical study, we will analyze two kinds of system settings A and B. For both the configurations the common parameters are:

- 1) $c = \frac{b}{10}$ W
- 2) $P_{\max} = 2$ W
- 3) $f(\gamma) = B \log(1 + \gamma)$
- 4) $\sigma^2 = 1$ mW

Where $B = 10^6$ hz is the bandwidth.

The fast fading co-efficient we consider is $\bar{h}_{i,j} = o(\pi_{m,k})\Omega + 0.1\xi$. Where $\xi \in CN(0, 1)$, a is the direct line of sight factor which plays a dominant role in most small cell networks, $o_{\pi_{m,k}} \in 0, 1$ is the shadow factor and $o(pi_{m,k}) = 1$ with probability $\pi_{m,k}$. Here $\pi_{m,k}$ is the probability that the receiver k has line of sight with the BS antenna m . We take $\pi_{m,k} = 0.5 \forall (k, m)$ for our simulations.

The presented results study the case of two users $K = 2$ served by a small cell cluster of three base stations, i.e $M = 3$. In addition to zero-forcing, when there are two users a single base station could also alternately use Orthogonal Frequency-Division Multiple Access (OFDMA) to serve the two users and keep the other two BS in sleep mode (i.e. . Our numerical simulations study all these possible scenarios and compare their respective EE performances.

In both of the settings presented below, we study two main regimes of interest:

- 1) $b = 1W$: This regime represents the futuristic case where power amplifier efficiencies are quite high and the constant power consumed is lower than the maximum RF output power.
- 2) $b = 10W$: This regime represents the more current state of the art w.r.t power amplifier efficiency where in small cell antennas, a large portion of the power is lost as a fixed cost.

We also consider two possible values of Ω , the line of sight factor. The case $\Omega = 10$ is representative of pico-cells that are deployed externally, whereas the case $\Omega = 0$ represents femto-cells deployed internally and no line of sight communication is possible.

A. Setting A

The deployment of antennas and the user locations are shown in Fig 2. In this setting we take $g_{m,k} = 1 \forall m, k$.

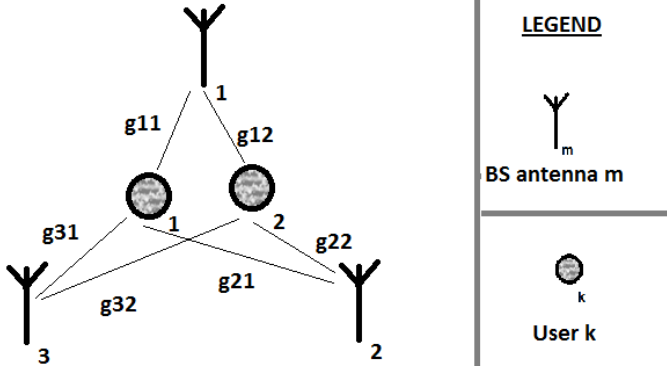

Fig. 2. Setting A schematic

In Fig 3 we study the EE of a VMIMO system with a very efficient power amplifier. In this figure, we notice that using all available base station antennas is more efficient when line of sight communications are possible. In this case, no BS is in sleep mode and all the antennas train and obtain feedback on their channels. The choice of β is very much relevant in this scenario. However in the regime where there is no direct line of sight (users are inside buildings), it becomes more efficient to just use 2 BS antennas and put one on sleep mode. As the configuration is symmetric, the choice of the base station in sleep mode is not relevant.

In Fig 4 we study the EE of a VMIMO system with an inefficient power amplifier. In this figure, we notice that using

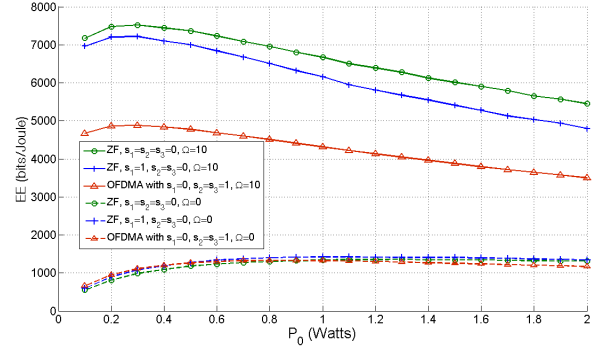

Fig. 3. Setting A: EE v.s P_0 for $b = 1 W$

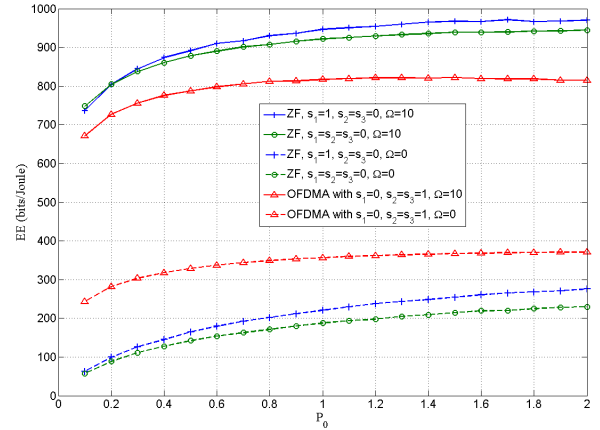

Fig. 4. Setting A: EE v.s P_0 for $b = 10 W$

all available base station antennas is not efficient even when line of sight communications are possible. In this case, having one BS in sleep mode and obtaining a 2×2 virtual MIMO with the other remaining antennas is the most efficient. Surprisingly, in the case of no line of sight, i.e $\Omega = 0$, we observe that using OFDMA with one BS active is the most efficient solution. This is explained by the relative inefficiency of zero-forcing in the low SNR regime, causing less energy to be spent by having two BS antennas in sleep mode and just one antenna transmitting for the two users in orthogonal frequencies.

B. Setting B

The deployment of antennas and the user locations are shown in Fig 5. In this setting we take $g_{1,1} = g_{2,1} = 4$, $g_{3,1} = g_{1,2} = g_{2,2} = 0.1$ and $g_{3,2} = 10$.

In Fig 6, similarly to what was done in the previous setting, we study the EE of a VMIMO system with a very efficient power amplifier. In this figure, for both $\Omega = 0$ and $\Omega = 1$ we see that having to use 2 BS antennas and put one on sleep mode is the most efficient. In this setting, the configuration of BS and users are asymmetric and the BS to be put in sleep mode has to be chosen carefully. BS 1 and 2 are symmetric and are close to user 1, but 3 is closer to user 2. In this case

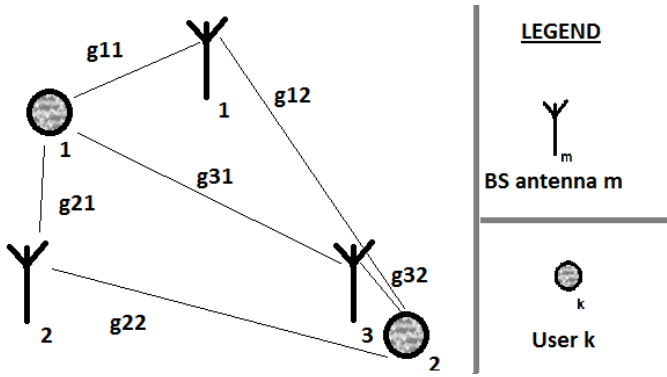

Fig. 5. Setting B schematic

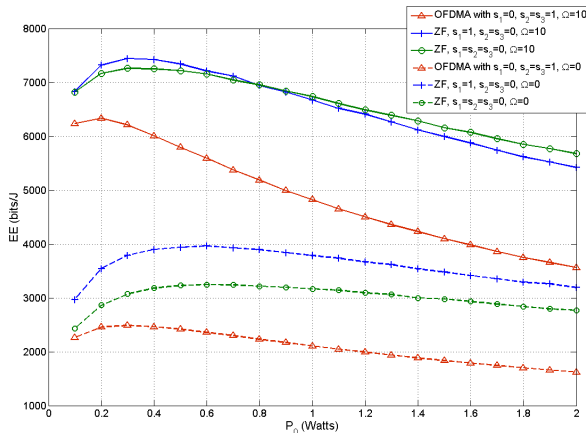

Fig. 6. Setting B: EE v.s P_0 for $b = 1$ W

choosing $s_1 = 1$ or $s_2 = 1$ is efficient, but $s_3 = 1$ is highly inefficient.

In this setting, we see from Fig 7 that unlike in Setting A, using OFDMA to divide resources between the two users is not as efficient as ZF due to the higher SNR when served by nearby BS antennas. Like in Fig 6, choosing $s_1 = 1$ or $s_2 = 1$ and zero-forcing is always the most efficient solution.

V. CONCLUSION

This paper studies the performance of virtual MIMO systems from an energy efficiency perspective. It defines an energy efficiency metric that takes into account the capacity as well as the energy consumption, and considers both fixed and variable parts of this latter. We optimize the power allocations of the different antennas and show that sleep mode can bring a significant energy efficiency gain. This involves deactivating antennas that do not have a significant contribution to the system capacity, for a given number of users and radio channel conditions.

This work is applicable only for the specific case of a small cell cluster with a centralized network and CSIT. Thus, many extensions of the proposed work are possible. The most relevant extension is to apply the proposed framework

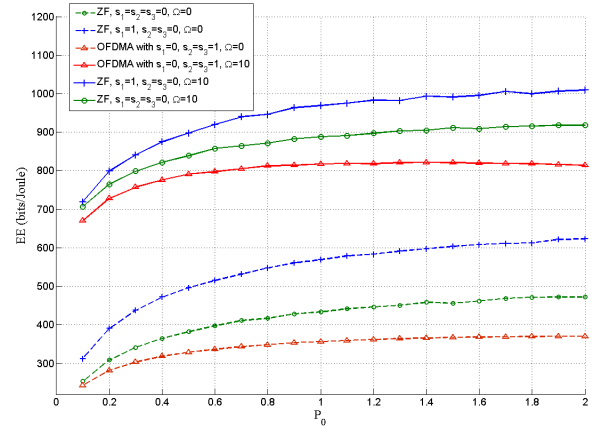

Fig. 7. Setting B: EE v.s P_0 for $b = 10$ W

taking into account user traffic and a random number of users. Another natural extension of the proposed framework is of course, to study the effect of different classes of mobility on the virtual MIMO scheme and to study a distributed network.

VI. ACKNOWLEDGMENTS

This work is a joint collaboration between Orange Labs, Laboratoire des signaux et systèmes (L2S) of Supélec and the Alcatel Lucent Chair of Supélec. This work is part of the European Celtic project ‘‘Operanet2’’.

REFERENCES

- [1] L. Saker, S-E. Elayoubi and H-O. Scheck, *System selection and sleep mode for energy saving in cooperative 2G/3G networks*, IEEE VTC 2009-Fall.
- [2] S-E. Elayoubi and O. Ben Haddada, *Uplink intercell interference and capacity in 3G LTE systems*, IEEE ICON 2007.
- [3] L. Saker, S-E. Elayoubi, R. Combes and T. Chahed, *Optimal control of wake up mechanisms of femtocells in heterogeneous networks*, Selected Areas in Communications, IEEE Journal on 30 (3), 664-672.
- [4] C.X Wang, X. Hong, X. Ge and X. Cheng, *Cooperative MIMO channel models: A survey*, IEEE communications magazine, Vol: 48, issue 2, 2010.
- [5] D. J. Goodman, and N. Mandayam, *Power Control for Wireless Data*, IEEE Personal Communications, vol. 7, pp. 48-54, Apr. 2000.
- [6] C. Desset et al. , *Flexible power modeling of LTE base stations*, IEEE Wireless Comm. and Networking Conference: Mobile and Wireless Networks, 2012.
- [7] V.S Varma, S. Lasaulce, M. Debbah and S-E. Elayoubi, ‘‘An Energy Efficient Framework for the Analysis of MIMO Slow Fading Channels’’, IEEE Trans. Signal Proc., Vol 61, 10, pp: 2647-2659, 2013.