



HAL
open science

Stability, as told by its developers

Antonio Loria, Elena Panteley

► **To cite this version:**

Antonio Loria, Elena Panteley. Stability, as told by its developers. IFAC 2017 - 20th World Congress of the International Federation of Automatic Control, Jul 2017, Toulouse, France. pp.5219 - 5230, 10.1016/j.ifacol.2017.08.459 . hal-01744940

HAL Id: hal-01744940

<https://hal.science/hal-01744940>

Submitted on 5 Mar 2020

HAL is a multi-disciplinary open access archive for the deposit and dissemination of scientific research documents, whether they are published or not. The documents may come from teaching and research institutions in France or abroad, or from public or private research centers.

L'archive ouverte pluridisciplinaire **HAL**, est destinée au dépôt et à la diffusion de documents scientifiques de niveau recherche, publiés ou non, émanant des établissements d'enseignement et de recherche français ou étrangers, des laboratoires publics ou privés.

Stability, as told by its developers^{*}

Antonio Loria[†] Elena Panteley^{**}

[†] CNRS, 91190, Gif sur-Yvette, France (e-mail: loria@lss.supelec.fr)

^{**} CNRS, 91190, Gif sur-Yvette, France; ITMO University, Saint Petersburg, Russia (e-mail: panteley@lss.supelec.fr)

Abstract: The general problem of the stability of motion was introduced by A. M. Lyapunov in his memoir Lyapunov (1892), published in French in 1907 —cf. (Lyapunov, 1947), translation which was revised by Lyapunov himself. Since then, many refinements have been made by a number of authors, but confusion regarding fundamental concepts has also settled through the years. Moreover, the effect of erroneous statements has been often amplified by inexact “recursive” citations (when an author A cites an author B, based on a text written by a tertiary author C). The purpose of this article is to present basic definitions and theorems on stability, mostly on *Lyapunov* stability, in the form of a concise but faithful account of the original statements made by the developers of stability theory, from the Italian G. L. Lagrangia to 20th century Soviet mathematicians. To that end, we rely on original sources to transcript the *exact* formulations of concepts introduced in the early literature, our translations are made with a maximum of fidelity, keeping at best both the original words and the mathematical notations. We hope, with this brief historical account, to revive the interest on otherwise forgotten fundamental literature on Lyapunov stability theory.

Keywords: Lyapunov stability, history of; Lagrange-Dirichlet stability; invariance principle.

“The authors of the present manuscript would like to insist on the fact that only the attentive reading of the original documents can contribute to correct certain errors endlessly repeated by different authors.”

J. J. Samuëli & J. C. Boudenot¹

1. STABILITY OF MOTION

To understand stability, consider²

a solution of a differential equation representing a physical phenomenon or the evolution of some system [...] There always exist two sources of uncertainty in the initial conditions. Indeed, when one attempts to repeat a given experiment, the reproduction of the initial conditions is never entirely faithful: for instance, a satellite can only be placed in orbit from one point and with a velocity that depend on the variable circumstances related to the launching of the rockets [...] It is thus fundamental to be able to recognize the circumstances under which small variations in the initial conditions will only introduce small variations in what follows of the phenomenon.

From a mathematical viewpoint, roughly speaking, stability may be described as a property of the solutions of differential equations by which, given a “reference” solution $x^*(t, t_0^*, x_0^*)$ to an ordinary differential equation

$$\dot{x} = f(t, x), \quad (1)$$

with initial conditions $(t_0^*, x_0^*) \in \mathbb{R}_{\geq 0} \times \mathbb{R}^n$, any other solution $x(t, t_0, x_0)$ starting close to the former (*i.e.* such

that $t_0^* \approx t_0$ and $x_0^* \approx x_0$), remains close to $x^*(t, t_0^*, x_0^*)$ for later times.

It is therefore apparent that the property of continuity of solutions with respect to initial conditions and therefore, the sufficient conditions for it, may bring an answer to the question of stability, posed above. However, as explained by Rouche and Mawhin (1980), the theorem on continuity of solutions with respect to initial conditions establishes sufficient conditions for a *perturbed* solution to remain “close” to an unperturbed solution over a *finite* interval of time. In the question of stability, however, this is insufficient since one requires that “small variations in the initial conditions [will] only introduce small variations in *what follows of the phenomenon*”, that is, from the initial time and for *ever* after.

The mathematical term “*perturbed* solution” is not innocuous. Even though in control theory we are most used to relate a *perturbation* to an external undesirable phenomenon that makes a system “misbehave” with respect to a desired performance, in classical stability theory of dynamical systems this term refers to the variation in the initial conditions, hence, we speak of *perturbed* initial conditions: $x_0 := x_0^* + \Delta_x$ and $t_0 := t_0^* + \Delta_t$.

To complement our generic discussion on stability and in order to properly explore the foundations of this theory, we find it important to recall the following terminology and notation. Following (Hahn, 1963, p. 1) [*sic*],

“a point of the real, n -dimensional space shall be denoted by the coordinates x_1, \dots, x_n . [...] In addition to the n -dimensional x -space which is also called *phase space*, we shall refer to the $(n + 1)$ -dimensional space of the quantities x_1, \dots, x_n, t , which will be called *motion space*. [...]”

^{*} See also Loria and Panteley (2006). This work was supported by CNRS under grant BFC 248824.

¹ Translated from *H. Poincaré (1854-1912), physicien*, Editions Ellipses: Paris, 2005.

² Quoted from the highly formative and enjoyable text Rouche and Mawhin (1973), see also Rouche and Mawhin (1980). By the second author see also the revealing papers Mawhin (2005, 1994).

The notation $\mathbf{x} = \mathbf{x}(t)$ indicates that the components x_i of \mathbf{x} are functions of t . If these functions are continuous, then the point $(\mathbf{x}(t), t)$ of the motion space moves along a segment of a curve as t runs from t_1 to t_2 , [...]

The projection of a motion upon the phase space is called the *phase curve*, or *trajectory*, of the motion. In this case the quantity t plays the role of a curve parameter.

The first to formally study the *stability of motion* was the Italian-French³ mathematician J.-L. Lagrange. Our survey starts with his work.

2. LAGRANGE'S STABILITY

“Messieurs DE LA PLACE, COUSIN, LE GENDRE et moi, ayant rendu compte d'un Ouvrage intitulé: Mécanique analytique, par M. DE LA GRANGE, l'Académie a jugé cet Ouvrage digne de son approbation, et d'être imprimé sous son Privilège.

Je certifie cet Extrait conforme aux registres de l'Académie. A Paris, ce 27 février 1788.

LE MARQUIS DE CONDORCET⁴

Section III of Part I of (de la Grange, 1788) entitled “General properties of the equilibrium of a bodies system” deals with the concepts of equilibrium and stability:

[Translated from (Lagrange, 1888, pp. 69–70)] In a system of bodies in equilibrium, the forces P, Q, R, \dots , stemming from gravity, are, as one knows, proportional to the masses of the bodies and, consequently, constant; and the distances p, q, r, \dots meet at the center of Earth. One will thus have, in such case,

$$\Pi = Pp + Qq + Rr + \dots;$$

[...] If one now considers the same system in motion, and let u', u'', u''', \dots be the velocities, and m', m'', m''', \dots be the respective masses of the different bodies that constitute it, the so well-known principle of *conservation of living forces* [...] will yield this equation:

$$m'u'^2 + m''u''^2 + m'''u'''^2 + \dots = \text{const.} - 2\Pi.$$

Recognizing that Π corresponds to the expression of potential energy and recalling that the “living forces” (*vis viva*) corresponds to the kinetic energy, we identify in Lagrange's text, the equation that expresses the principle of energy conservation.

In the following paragraph Lagrange makes an interesting citation that he attributes to Courtivron⁵ and which, to some extent, already speaks of stability:

[Translated from (Lagrange, 1888, p. 70)] Hence, since in the state of equilibrium, the quantity Π is [has] a

³ While mostly known as a *french* mathematician, Joseph Louis de la Grange was born Giuseppe Lodovico Lagrangia on the 25th of January 1736 in Turin, Sardinia-Piemonte (now part of Italy) where he lived and taught mathematics until 1766; he moved to Paris only in 1787.

⁴ So finishes the preface to the first edition of the famous treatise on analytical mechanics by Lagrange (of noble status), which occupied his gifted mind “on the eve” of the French Revolution ...

⁵ In Lagrange (1888), the cited text is accompanied by a footnote of J. Bertrand, editor of the 3rd edition of Lagrange's treatise, who comments that Lagrange had attributed in de la Grange (1788), the mentioned principle from statics to the [*sic*] “little-known geometrician Courtivron” but that Lagrange had removed Courtivron's name from the second edition to substitute it with the date of publication.

minimum or a maximum, it follows that the quantity $m'u'^2 + m''u''^2 + m'''u'''^2 + \dots$, which represents the living force of the whole system, will be at same time a minimum or a maximum; this leads to the following principle of Statics, that, *from all the configurations that the system takes successively, that in which it has the largest or the smallest living force, is that where it would be necessary to place it initially so that it stayed in equilibrium.* (See the Mémoires de l'Académie des Sciences de 1748 et 1749.)

Lagrange continues his essay on the properties of the equilibrium by making his famous statement that the minimum of the potential energy of a mechanical system corresponds to a stable equilibrium point whereas the potential energy function has a maximum at a point corresponding to an unstable equilibrium:

[Translated from (Lagrange, 1888, p. 71)] [...] we will show now that if this function [Π] is a minimum, the equilibrium will have stability; similarly, if the system being initially supposed at the state of equilibrium and then coming to be, no matter how little, displaced from such state, it will tend itself to come back to that position while making infinitely small oscillations: and on the contrary, in the case that the same function will be a maximum, the equilibrium will have no stability, and once perturbed, the system will be able to make oscillations that will not be very small, and that may make it to drift farther and farther from its first state.

In modern terminology we can state stability in the sense of Lagrange (1888) as follows.

Definition 1. Consider a mechanical system with state $x := \text{col}[q, \dot{q}]$. We say that the point $q = 0$ is stable if for each $\delta > 0$

$$|q(t_0)| \leq \delta \implies |x(t)| \rightarrow 0 \quad \forall t \geq t_0 \geq 0.$$

Remark 1. We stress the ambiguity of “it will tend itself to come back to that position”. Indeed, instead of the implication above one may interpret Lagrange's stability as the property such that $|q(t_0)| \leq \delta \implies |q(t)| \rightarrow 0$ —see Rouche and Peiffer (1967).

Lagrange claims that the minimum of the potential energy corresponds to a stable point, in the sense previously defined. The proof of his statement is based on a series expansion of the function Π and makes use of the abusive assumption that high-order terms are negligible. According to G. Lejeune-Dirichlet⁶, Poisson seems to have been the first to point out this inaccuracy and tried to correct it by supposing that the terms of second order dominate largely over terms of order greater than two, in his⁷ *Traité de Mécanique*, p. 492. It was, however, G. Lejeune-Dirichlet who provided the first rigorous proof of Lagrange's statement. Dirichlet's proof is worth stressing since it is the basis of Lyapunov's direct method:

⁶ We have this from Lejeune-Dirichlet (1888) but according to J. Bertrand, Dirichlet's proof was originally published in the *Journal de Crelle*, Vol. 32 and the *Journal de Liouville*, 1st series, Vol. XII, p. 474.

⁷ G. Lejeune-Dirichlet (1805–1859), contemporary of Poisson (1781–1840), does not give a complete reference for Poisson's work; according to Rouche and Peiffer (1967), the complete reference is Poisson (1838).

[Translated from (Lejeune-Dirichlet, 1888, p. 457)] The function of coordinates depends only on the nature of forces and can be expressed by a defined number of independent variables λ, μ, ν, \dots , in such a way that the equation of living forces will be written as

$$\sum mv^2 = \varphi(\lambda, \mu, \nu, \dots) + C$$

[...] the condition that expresses that, [...] the system is at an equilibrium position, coincides with that which expresses that, for these same values, the total derivative of φ is zero; hence, for each equilibrium position, the function will be a maximum or a minimum. If a maximum takes place, then the equilibrium is stable, that is, if one displaces infinitely little the points [coordinates] of the system from their initial values, and we give to each a small initial velocity, in the whole course of the motion the displacements of the points of the system, with respect to their equilibrium position, will remain within certain defined very small limits.

Notice that Dirichlet speaks of *maximum* of the function $\varphi(\lambda, \mu, \nu, \dots)$ corresponding to a *stable* equilibrium; this makes sense if we consider that in modern notation the potential energy corresponds to $-\varphi$ and the independent coordinates λ, μ, ν, \dots correspond to the generalized coordinates of a Lagrangian system —see (Goldstein, 1974). Another interesting characteristic of Dirichlet's stability is that he adds to his definition, with respect to that of Lagrange, the condition that the initial velocities be small in order to produce small displacements; in modern terms we might put it as follows.

Definition 2. Let $x := \text{col}[q, \dot{q}]$. We say that the point $q = 0$ is stable if for each $\delta > 0$ there exists $\varepsilon > 0$ such that

$$|x(t_0)| \leq \delta \implies |x(t)| \leq \varepsilon \quad \forall t \geq t_0 \geq 0.$$

Dirichlet's proof of the fact that the minimum of the potential energy corresponds to a stable equilibrium is quite interesting to us since it is close, in spirit, to what we currently know as Lyapunov theory:

[Translated from (Lejeune-Dirichlet, 1888, p. 459)]

Other than the hypothesis already made, that the equilibrium position corresponds to the values $\lambda = 0, \mu = 0, \dots$, we will also suppose that $\varphi(0, 0, 0, \dots) = 0$; [...] hence,

$$\sum mv^2 = \varphi(\lambda, \mu, \nu, \dots) - \varphi(\lambda_0, \mu_0, \nu_0, \dots) + \sum mv_0^2.$$

Since by hypothesis, $\varphi(\lambda, \mu, \nu, \dots)$, for $\lambda = 0, \mu = 0, \dots$, is zero or maximum, we will be able to determine positive numbers l, m, n, \dots , sufficiently small so that $\varphi(\lambda, \mu, \nu, \dots)$ be always negative [...] where the absolute values of the variables be respectively constrained not to overpass the limits l, m, n, \dots , [...] Let us suppose that, among all the negative values of the function [...], $-p$, except for the sign, is the smallest: then we can easily show that, if we take $\lambda_0, \mu_0, \nu_0, \dots$ numerically smaller than l, m, n, \dots , and at same time one satisfies the inequality

$$-\varphi(\lambda_0, \mu_0, \nu_0, \dots) + \sum mv_0^2 < p,$$

each of the variables λ, μ, ν, \dots will remain during the complete duration of the motion below the limits l, m, n, \dots . Indeed, if the contrary took place, since the initial values $\lambda_0, \mu_0, \nu_0, \dots$ and due to the continuity of

the variables λ, μ, ν, \dots , it would first be necessary that at some instant one or more numerical values of λ, μ, ν, \dots were equal to their respective limits l, m, n, \dots , without having any other value overpassing its limit. At this instant, the absolute value of $\varphi(\lambda_0, \mu_0, \nu_0, \dots)$ would be larger or at least equal to p . Consequently, the second member of the equation of living forces [i.e., the kinetic energy term] would be negative, due to the inequality above written, and which corresponds to the initial state; which is not possible, $\sum mv^2$ being always positive.

Dirichlet's proof can be explained in modern terms using the total energy function, in terms of generalized positions $q := \lambda, \mu, \nu, \dots$ and velocities \dot{q} , i.e.

$$V(q, \dot{q}) := T(q, \dot{q}) + U(q)$$

where $T(q, \dot{q}) := \sum mv^2$ and $U(q) := -\varphi(\lambda, \mu, \nu, \dots)$, i.e. in general v depends on the generalized velocities and positions and the potential energy is assumed to depend only on the positions. Moreover, as Dirichlet points out, we can assume without loss of generality that $U(0) = 0$. Then, Dirichlet poses

$$p := \min\{U(q) : |\lambda| = l, |\mu| = m, |\nu| = n \dots\}$$

Now, consider initial positions $q(t_0)$ and velocities $\dot{q}(t_0)$ such that $V(q(t_0), \dot{q}(t_0)) < p$, the equation of living forces (principle of energy conservation) is

$$V(q(t), \dot{q}(t)) = V(q(t_0), \dot{q}(t_0))$$

so, necessarily, we have $V(q(t), \dot{q}(t)) < p$ for all $t \geq t_0$. Equivalently, $T(q(t), \dot{q}(t)) + U(q(t)) < p$ for all $t \geq t_0$. Since $T(q(t), \dot{q}(t)) \geq 0$ it follows that $U(q(t)) < p$ and therefore, none of the variables λ, μ, ν, \dots , can overpass its respective limit.

We see clearly that key concepts such as positive definiteness of certain function V as well as negative semidefiniteness of its derivative are implicit in Dirichlet's proof. Indeed, the key property used is the positivity of the kinetic energy T ; notice that $V(q(t), \dot{q}(t)) = V(q(t_0), \dot{q}(t_0))$ is equivalent to $\dot{V}(q(t), \dot{q}(t)) = 0$, for the case that V is differentiable. However, $V(q(t), \dot{q}(t)) = V(q(t_0), \dot{q}(t_0))$ being the *integral* of the living forces equation, in Dirichlet's proof it is not required that the energy function be differentiable.

2.1 Modern use of Lagrange stability

Holding rigour to Lagrange, we might say that his definition of stability rather relates to a property of convergence of part of the coordinates; this differs from Dirichlet's interpretation of Lagrange's stability, which rather hints at a property of boundedness of solutions. It is this, or yet another slight variant of it, which has been retained in modern literature as "*stability in the sense of Lagrange*". Hahn (1963, p.129) attributes it to La Salle (1960), where one can read:

"the boundedness of all solutions for $t \geq 0$ is also a kind of stability, called *Lagrange stability*."

In contemporary texts we find the following.

Definition 3. (Lagrange stability). The system (1) is said to be Lagrange stable if for each $\delta > 0$ there exists $\varepsilon > 0$ such that

$$|x(t_0)| \leq \delta \implies |x(t)| \leq \varepsilon \quad \forall t \geq t_0 \geq 0.$$

3. LYAPUNOV'S STABILITY

“J’ai seulement eu en vue d’exposer dans cet Ouvrage ce que je suis parvenu à faire en ce moment et ce qui, peut-être, pourra servir de point de départ pour d’autres recherches de même genre.”

A. M. Liapounoff, 1907

With this sentence⁸ Lyapunov closes his preface to the French translation of his famous memoir on stability of motion; here transcribed *verbatim* from (Lyapunov, 1947). As it is well known, however, it was in the original version of the latter, (Lyapunov, 1892), that the author set the basis of the stability theory mostly used nowadays in the literature of automatic control.

It is following up the work of Lagrange, Dirichlet, Poincaré and other mathematicians who contributed to the foundations of analytical and celestial mechanics, that Lyapunov seems to have come to the theory that we know. In the introduction of his memoir he considers

[Translated from (Lyapunov, 1947, p. 209)] [...] a material [physical] system with k degrees of freedom. Let

$$q_1, q_2, \dots, q_k$$

be k independent variables by which we agree to define its position. [...] Considering such variables as functions of time t , we will denote their first derivatives, with respect to t , by

$$q'_1, q'_2, \dots, q'_k.$$

In each problem of dynamics, [...] these functions satisfy k second-order differential equations.

Then, on the basis of a physical dynamic system, Lyapunov proceeds to introduce his notation for the study of stability of ordinary differential equations with respect to arbitrary solutions:

Let us assume that a particular solution is found to be

$$q_1 = f_1(t), q_2 = f_2(t), \dots, q_k = f_k(t),$$

in which the quantities q_j are expressed by real functions of t , [...] To this particular solution corresponds a determined motion of our system. By comparing it, according to certain relation, to other motions of this system, possibly under the same forces, we will call it *unperturbed motion*, and for all the rest, with respect to which it is compared, will be said to be *perturbed motions*.

That is, we are interested in studying the behaviour of any solution, or rather, as we will see below, a given function of any solution, with respect to another given function of one particular solution. As we recalled from Hahn (1963), the word perturbation refers to a (small) change in the initial conditions that generate the unperturbed motion [*sic*]:

Denoting by t_0 an arbitrary time instant, let us denote the corresponding values of the quantities q_j, q'_j , of an arbitrary motion, by q_{j0}, q'_{j0} . Let

$$q_{10} = f_1(t_0) + \varepsilon_1, q_{20} = f_2(t_0) + \varepsilon_2, \dots, q_{k0} = f_k(t_0) + \varepsilon_k, \\ q'_{10} = f'_1(t_0) + \varepsilon'_1, q'_{20} = f'_2(t_0) + \varepsilon'_2, \dots, q'_{k0} = f'_k(t_0) + \varepsilon'_k,$$

where $\varepsilon_j, \varepsilon'_j$ are real constants. These constants, that we will call *perturbations*, will define a perturbed motion.

⁸ “I only pretended to expose in this Work what I managed to do at this moment and which, maybe, will serve as starting point for other studies of the same type”.

[...] let Q_1, Q_2, \dots, Q_n be given continuous and real functions of the quantities

$$q_1, q_2, \dots, q_k, \quad q'_1, q'_2, \dots, q'_k.$$

For the unperturbed motion they will become known functions of t that we will denote respectively by F_1, F_2, \dots, F_n . For a perturbed motion they will become functions of the quantities

$$t, \varepsilon_1, \varepsilon_2, \dots, \varepsilon_k, \quad \varepsilon'_1, \varepsilon'_2, \dots, \varepsilon'_k.$$

When the $\varepsilon_j, \varepsilon'_j$ are equal to zero, the quantities

$$Q_1 - F_1, \quad Q_2 - F_2, \quad \dots, \quad Q_n - F_n$$

will be zero for each value of t .

The question that Lyapunov poses next is the following:

if without making the constants $\varepsilon_j, \varepsilon'_j$ zero, we make them infinitesimally small, [...] [is it] possible to assign to the quantities $Q_s - F_s$ infinitely small limits, such that these quantities never reach them in absolute value? The solution to this question, [...] will be the subject of our research [...] property that we will call *stability*.

In contrast to Lagrange and Dirichlet Lyapunov gives a more formal definition of stability than described above:

[Translated from (Lyapunov, 1947, pp. 210-211)] Let L_1, L_2, \dots, L_n be positive given numbers. If for all values of these numbers, no matter how small they are, one can choose positive numbers

$$E_1, E_2, \dots, E_k \quad E'_1, E'_2, \dots, E'_k,$$

such that, if the inequalities

$$|\varepsilon_j| < E_j, \quad |\varepsilon'_j| < E'_j \quad (j = 1, 2, \dots, k)$$

hold, then we have that

$$|Q_1 - F_1| < L_1, \quad |Q_2 - F_2| < L_2, \quad \dots, \quad |Q_n - F_n| < L_n$$

for all values of t greater than t_0 , the *unperturbed* motion will be called stable WITH RESPECT TO THE QUANTITIES Q_1, Q_2, \dots, Q_n ; in the opposite case, it will be called unstable with respect to the same quantities.

Note that Lyapunov’s stability is broader than that of Lagrange or Dirichlet since he considers the stability of functions of $q(t)$ and their derivatives, not only of $q(t)$ and $q'(t)$ themselves. Moreover, he assumes that one can have different functions Q_i and F_i for each q_i . For the case that the functions F_i are the identity, Lyapunov’s stability is more restrictive (and at the same time a stronger property) than that of Lagrange-Dirichlet since Lyapunov considers stability with respect to *all* the coordinates and not only with respect to the displacements. The fact that Lyapunov’s stability refers to a *function of the solutions* is still a fundamental contribution with respect to what was known from *Analytical Mechanics*; in the rest of his memoir, Lyapunov is devoted to study the stability of the difference $Q_i - F_i$:

[Translated from (Lyapunov, 1947, pp. 212)] The solution to our question depends on the study of differential equations of the perturbed motion or, in other words, of the study of the differential equations satisfied by the functions

$$Q_1 - F_1 = x_1, \quad Q_2 - F_2 = x_2, \quad \dots, \quad Q_n - F_n = x_n.$$

[...] We will assume that the number n and the functions Q_s are such that the order of this system is n and that the former [the system] has the normal form

$$(1) \quad \frac{dx_1}{dt} = X_1, \quad \frac{dx_2}{dt} = X_2, \quad \dots, \quad \frac{dx_n}{dt} = X_n,$$

From the above formulations we recover the familiar definition that we are used to see in many textbooks (*e.g.* Khalil (2002); Vidyasagar (1993); Rouche and Mawhin (1980)):

Definition 4. (Lyapunov stability). The origin is a *stable equilibrium* of Equation (1) if, for each pair of numbers $\varepsilon > 0$ and $t_0 \geq 0$, there exists $\delta = \delta(t_0, \varepsilon) > 0$ such that

$$|x(t_0)| < \delta \implies |x(t)| < \varepsilon \quad \forall t \geq t_0 \geq 0.$$

In some texts and articles, starting probably with Hahn (1967), one also finds the following definition of stability:

Definition 5. (Lyapunov stability). The origin is a *stable equilibrium* of Equation (1) if there exists $\varphi \in \mathcal{K}$ such that

$$|x(t, t_0, x_0)| \leq \varphi(|x_0|) \quad \forall t \geq t_0 \geq 0. \quad (2)$$

In general, the function φ depends on t_0 . We recall, from Hahn (1967), that $\varphi \in \mathcal{K}$ if it is “*defined, continuous, and strictly increasing on $0 \leq r \leq r_1$, resp. $0 \leq r < \infty$, and if it vanishes at $r = 0$: $\varphi(0) = 0$* ”. It is of class \mathcal{K}_∞ if, moreover, $\varphi(s) \rightarrow \infty$ as $s \rightarrow \infty$.

Whether we adopt Lagrange’s original concept of stability (Definition 1), Dirichlet’s interpretation (Definition 2), or its modern form (Definition 3), note that Lagrange stability is mathematically different from Lyapunov’s stability (Definition 4) —the order in which δ and ε are defined is inverted in the last two definitions. On the other hand, Hahn (1967) shows that Definitions 4 and 5 are equivalent.

3.1 Conditions for stability

Lyapunov’s memoir contains two now well-known methods: the first, relying on a linearisation about the equilibrium point and the second, based on what Soviet mathematicians would call later, *Lyapunov* functions; the terminology “second method” and “first method” was chosen by Lyapunov himself. He also introduced the method of characteristic exponents which was independently proposed by Poincaré (1890).

[Translated from (Lyapunov, 1947, p. 256)]

15. We shall consider here real functions of the real variables

$$(39) \quad x_1, x_2, \dots, x_n, t,$$

subject to constraints of the form

$$(40) \quad t \geq T, \quad |x_s| \leq H \quad (s = 1, 2, \dots, n),$$

where T and H are constants, which may be assumed to be, the first, as large as wanted, the second, as small as wanted (but not zero). [...] Let us suppose that the considered function V is such that, under the conditions (40), T being sufficiently large and H sufficiently small, it can only take values of a single sign.

We shall say then, that it is a *function of fixed sign*; and when it will be needed to indicate its sign, we shall say that it is a *positive function* or a *negative function*.

If, moreover, the function V does not depend on t and if the constant H can be chosen sufficiently small so that, under the conditions (40), the equality $V = 0$ cannot occur unless we have

$$x_1 = x_2 = \dots = x_n = 0,$$

we shall call the function V , as if it were a quadratic function, *definite function* or, trying to attract attention on its sign, *positive definite* or *negative definite*.

It is in such terms that Lyapunov introduced what we call nowadays, positive definite and negative definite (Lyapunov) functions. Except for the fact that Lyapunov defined the properties of *his* functions, only locally, the definitions above are equivalent to those found in modern literature. Then, he states his theorem on stability, which is clearly inspired by Dirichlet’s proof of Lagrange’s initial statement.

[Translated from (Lyapunov, 1947, pp. 258-259)]

Everybody knows Lagrange’s theorem on the stability of the equilibrium in the case when there exists a function of the forces, as well as the elegant demonstration given by Lejeune-Dirichlet. The latter relies on considerations that may serve the demonstration of many other analogous theorems.

Guided by these considerations we will establish here the following propositions:

THEOREM I.— If the differential equations of the perturbed motion are such that it is possible to find a definite function V , whose derivative V' is a function of fixed sign and opposite to that of V , or it is exactly zero, the unperturbed motion is stable.

It is worth mentioning that the sign of V is irrelevant, as long as it is defined and opposite to that of its derivative. Lyapunov’s proof starts with the sentence: “*Let us suppose, to fix the ideas, that the function found V is positive definite and that its derivative V' is negative or identically zero.*” Thereby setting a convention used till today.

Equivalent statements to Lyapunov’s original theorem include (Hahn, 1967, Theorem 25.1, p. 102), (Vidyasagar, 1993, Theorem 1, Section 5.3.1, p. 158), (Rouche et al., 1977, Theorem 4.2, p. 13), (Rouche and Mawhin, 1980, Theorem 4.6, p. 12), (Khalil, 1992, Theorem 3.1, p. 101), (Khalil, 2002, Theorem 4.1, p. 114), to mention a few.

3.2 Asymptotic Stability

Consider again N. Rouche’s example of a satellite put in orbit and for which it is practically impossible to repeat *exactly* the same conditions every time. Lagrange stability gives account of whether small initial errors in the satellite configuration, with respect to a point in its desired orbit, will lead only to small variations. If, however, for a given error tolerance we wish to determine the initial errors that one can allow when launching the satellite, Lyapunov stability theory is more appropriate. Neither of them, however, tells us whether the generated small errors vanish asymptotically. For this, Lyapunov introduced the property of asymptotic stability [*sic*]:

[Translated from (Lyapunov, 1947, p. 261)]

Remark II. — If the function V , while satisfying the conditions of the theorem [THEOREM I above], allows an infinitely small upper bound, and if its derivative represents a definite function, one can show that every perturbed motion, sufficiently close to the unperturbed motion, will approach the latter asymptotically.

The terminology “admits an infinitely small upper bound” was common in Soviet literature at least till the 1950s; since, at least, Hahn (1963) this quality of certain functions is referred to as “decreascent”. Notice also that Lyapunov only says that the derivative of V should be *definite*; however, according to “THEOREM I” and the way he

introduced *his* functions, it is clearly understood that he means definite and of opposite sign to that of V .

The definition of asymptotic stability became more precise in Soviet literature that succeeded Lyapunov. For instance, Krasovskii (1963) says, just before presenting the definitions of stability and asymptotic stability, that “*some of the definitions of refined types of stability follow Četaev’s annotations in (Četaev, 1956, pp. 11-36)*”. The definition provided in Krasovskii (1963) is as follows:

[Cited from (Krasovskii, 1963, p. 3)]

DEFINITION 1.2. The null solution $x = 0$ of the system (1.3)

$$\left[\frac{dx_i}{dt} = X_i(x_1, \dots, x_n, t) \quad (i = 1, \dots, n) \quad (1.3) \right]$$

is called asymptotically stable and the region G_δ of x -space is said to lie in the region of attraction of the point $x = 0$ (at $t = t_0$), provided that the conditions of definition 1.1 [here, Definition 4] are satisfied, and provided further that

$$\lim_{t \rightarrow \infty} x(x_0, t_0, t) = 0, \\ x(x_0, t_0, t) \in \Gamma, \quad t \geq t_0,$$

for all values of the initial point x_0 that lie in G_δ . Here Γ is some sub-region of G which is given in advance, and with which the physical problem is intrinsically concerned.

Remark 2. In (Krasovskii, 1963) G is a region of the state space in which X_i are continuous, not to be confused with the set of initial states G_δ . Indeed, $G_\delta \subset \Gamma \subset G$.

The property that $|x_0| \leq \delta$ implies that

$$\lim_{t \rightarrow \infty} x(t, t_0, x_0) = 0$$

was sometimes called (see, *e.g.*, Hahn (1963), Antosiewicz (1958)) *quasi-asymptotic stability* and it was replaced with the more precise statement that $|x_0| < \delta$ implies that for each $\eta > 0$ there exists $T(\eta) > 0$ such that⁹

$$|x(t, t_0, x_0)| < \eta \quad \forall t > t_0 + T.$$

In general, as W. Hahn remarks, the number T depends on x_0 and on t_0 .

This brings us to the following well-adopted definition of asymptotic stability: *the equilibrium is asymptotically stable if it is stable and attractive* —*cf.* (Vidyasagar, 1993, Definition 31, p. 141), (Rouche and Mawhin, 1980, Definition 2.11, p. 6), (Khalil, 2002, Definition 4.1, p. 112). More precisely, we say:

Definition 6. (Asymptotic stability). We say that the origin of (1) is asymptotically stable if it is stable in the sense of Definition 4 and there exists $\delta > 0$ and, for each $\eta > 0$ and $t_0 \geq 0$, $\exists T(\eta, t_0) > 0$, such that

$$|x_0| < \delta \implies |x(t, t_0, x_0)| < \eta \quad \forall t > t_0 + T. \quad (3)$$

4. THE SET OF INITIAL CONDITIONS

[Cited from (La Salle, 1960, p. 521)]

it is never completely satisfactory to know that the system is asymptotically stable without some idea of the size of the region of asymptotic stability [...] Ideally, we might like to have that the system return to equilibrium regardless of the size of the [initial] perturbation.

⁹ Hahn (1967) uses $p(t, t_0, x_0)$ to denote the solutions; we use the more common notation $x(t, t_0, x_0)$.

The same interest, to give conditions for asymptotic stability under “large” initial perturbations (*i.e.* initial conditions) was present in (earlier) Soviet literature.

According to (Hahn, 1967, p. 109), [*sic*]

If the domain of attraction is all of \mathbb{R}^n we speak of *asymptotic stability in the whole*, (*cf.* sec 2) or also of *global asymptotic stability* [...]

La Salle (1960) speaks of *complete asymptotic stability*. In most of modern literature, as *e.g.* in the texts Vidyasagar (1993); Slotine and Li (1987); Khalil (2002), we use the qualifier “global” in *global asymptotic stability*, to refer to the case when asymptotic stability holds for all initial states in the Euclidean space \mathbb{R}^n . Hence, we have the following.

Definition 7. (Global asymptotic stability). We say that the origin of (1) is globally asymptotically stable if it is stable in the sense of Definition 4 and globally attractive, *i.e.* for each $\delta > 0$, $\eta > 0$ and $t_0 \geq 0$ there exist $T(\eta, t_0) > 0$, such that (3) holds.

When the set of initial conditions for which the property of asymptotic stability holds is not an arbitrarily small neighbourhood of the origin but it is not, either, the Euclidean space, we speak of asymptotic stability *in the large* (Barbashin and Krasovskii, 1952). It must be stressed, however, that this terminology is mistakenly used to speak of *global asymptotic stability*, which is synonym of asymptotic stability *in the whole*. Indeed, from early literature to modern texts in English, there exists considerable confusion regarding the qualifiers “in the whole” and “in the large”; in Russian “*v tselom*” (IPA: [v ts’el’om]) and “*v bolshom*” (IPA: [v bel’šom]) respectively.

The notions of *asymptotic stability in the whole* (global) and *asymptotic stability in the large* are *not* synonyms and clarifying the difference is beyond pedantic semantics’s interest; mathematically, both properties are different. As N. N. Krasovskii puts it:¹⁰

(Translated from (Krasovskii, 1954, p. 149)) When addressing questions of stability in the large^[1] the interest [resides on] the estimate of the domain of stability (in the case when there is no stability in the whole).

Hahn (1963) explains us the difference between asymptotic stability *in the large* and asymptotic stability *in the whole* and warns us against the mistaken translations:

[Cited from (Hahn, 1963, p. 8)] If relation (2.10) [Expression (3) In Def. 6] is valid for *all* points x_0 from which motions originate, we shall say that the equilibrium is *asymptotically stable in the large* (Aizerman (1952), Krasovskii (1954)). If relation (2.10) holds for all points of the phase space, the equilibrium is said to be *asymptotically stable in the whole* (Barbashin and Krasovskii (1952, 1954)). La Salle (1960) proposed “complete stability.” The distinction between asymptotic stability in the large and asymptotic stability in the whole has often been obliterated by inaccurate translations of the Russian terminology. However, it becomes important in cases where Eq (2.7) [$\dot{x} = f(t, x)$] is not defined for all points of the phase space.

¹⁰The upper index [1] in the citation corresponds to the book Aizerman (1952), which we have not been able to locate.

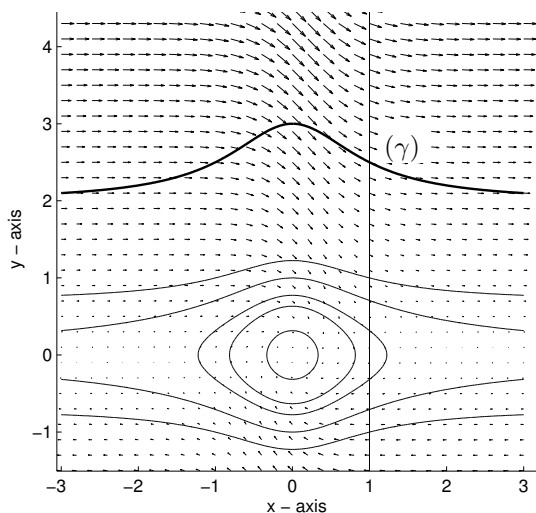

Fig. 1. Example from Barbashin and Krasovskii (1952) illustrating stability in the large. The figure is repeated from the latter reference.

One cannot overestimate the last two sentences of the latter passage. The first warns us against the wrong translation of the term “*v tselom*”:

[Cited from (La Salle, 1960, p. 524)]

For many systems it may be important to assure that no matter how large the perturbation, or in a feedback control system, regardless of the size of the error, the system tends to return to its equilibrium state. This is asymptotic stability in the large.

In writing this sentence, *perhaps*¹¹, La Salle had in mind the seminal article (Barbashin and Krasovskii, 1952) which set the basis of global asymptotic stability, as we know it, and whose title is commonly mistranslated in the literature.

The last sentence in the cited paragraph of Hahn above, clearly states that asymptotic stability in the large is significant when the property holds in a region of stability which is a subset of the phase space. Such is the property that one should speak about when dealing with systems on manifolds, such as the rigid body in quaternion coordinates. From a more academic viewpoint, Barbashin and Krasovskii (1952) propose to study the system of differential equations

$$\dot{x} = -\frac{2x}{(1+x^2)^2} + 2y, \quad \dot{y} = -\frac{2y}{(1+x^2)^2} - \frac{2x}{(1+x^2)^2}$$

using the Lyapunov function

$$v(x, y) = y^2 + \frac{x^2}{1+x^2} \quad (4)$$

The authors show that there exists an open domain in the phase space from which all solutions converge to the origin and the latter is Lyapunov stable. Indeed, they show, by solving the system’s differential equations, that trajectories starting above the curve (γ) and to the right of the straight line $x = 1$ in Figure 1, diverge while trajectories generated by initial conditions below the curve (γ) converge to zero. A conservative, but typical, estimate of the domain of attraction, is any compact containing the origin.

¹¹ The article is not cited by La Salle.

In spite of its obvious utility, we have not been able to locate in non-Russian literature a precise definition of *asymptotic stability in the large*. What is more, this concept seems to have been forgotten and the reference to Hahn’s clear texts are scarce. Section “Stability in the large, in the whole” in Furasov (1977) is a rare piece of text dealing with both concepts in certain rigour:

[Translated from (Furasov, 1977, p. 29)]

Definition 6.1. Let Δ_0 be a given positive number. The unperturbed motion Σ is called *asymptotically stable in the large*, if this motion is Lyapunov stable and condition (2.5) [$x(x_0, t) \rightarrow 0$ as $t \rightarrow \infty$] is satisfied for any initial perturbations x_0 from the region

$$|x_0| \leq \Delta_0.$$

Asymptotic stability in the large is also abundantly and clearly discussed in Krasovskii (1963), but in the realm of non-autonomous systems.

For asymptotic stability in the whole we recall the original definition as given in the milestone paper (Barbashin and Krasovskii, 1952):

[Translated from Barbashin and Krasovskii (1952)]

We say, that the trivial solution $x_i = 0$ of systems (1)

$$\left[\frac{dx_i}{dt} = X_i(x_1, x_2, \dots, x_n), \quad i = 1, 2, \dots, n, \quad (1) \right]$$

is asymptotically stable for any initial perturbations if it is stable in the sense of Lyapunov (for sufficiently small perturbations) and if each other solution $x_i(t)$ of systems (1) posses the property $\lim_{t \rightarrow \infty} x_i(t) = 0$, $i = 1, 2, \dots, n$.

That is, recalling that the “initial perturbations” correspond to the initial states away from zero, we see that E. A. Barbashin and N. N. Krasovskii defined stability with respect to *arbitrary initial conditions* as local stability plus attractivity of the origin for *all* other solutions, *i.e.*, for all initial conditions. Even though the authors do not use, in the definition itself, the terminology *asymptotic stability in the whole* the previous definition can be adopted as such.

For the sake of comparison with the definition given by Furasov, for asymptotic stability in the large (Definition 6.1 above), we recall the following:

[Translated from (Furasov, 1977, p. 30)]

Definition 6.2. The unperturbed motion Σ is called *asymptotically stable in the whole* if this motion is stable [in the sense of] Lyapunov and the condition (2.5) [$x(x_0, t) \rightarrow 0$ as $t \rightarrow \infty$] is satisfied for any initial perturbations x_0 no matter how large they would be.

5. CONDITIONS FOR ASYMPTOTIC STABILITY

Interestingly, the lack of clarity regarding the terminology has not impeded, however, to make statements on the sufficient conditions for asymptotic stability in the large, albeit not explicitly:

[Paraphrased from (La Salle and Lefschetz, 1961, pp. 58-59, THEOREMS VI and VII)]

THEOREM. Let $V(x)$ be a scalar function with continuous first partial derivatives. Let Ω_l designate the region where $V(x) < l$. Assume Ω_l is bounded and that within Ω_l :

$$V(x) > 0 \quad \text{for} \quad x \neq 0, \quad (\text{a})$$

$$\dot{V}(x) < 0 \quad \text{for all} \quad x \neq 0 \text{ in } \Omega_l \quad (\text{b})^*$$

then, the the origin is asymptotically stable, and above all, every solution in Ω_l tends to the origin as $t \rightarrow \infty$ (The last conclusion goes beyond Lyapunov's asymptotic stability theorem).

The comment in parenthesis is significant: the authors emphasize that (La Salle and Lefschetz, 1961, Theorem VII) establishes asymptotic stability in a much larger region than “a neighbourhood” of the origin as originally stated by Lyapunov. Therefore, this theorem comes to determine what La Salle called “*the extent of asymptotic stability*” in (La Salle, 1960; La Salle and Lefschetz, 1961).

The sufficient (and necessary) conditions for asymptotic stability in the whole, for autonomous systems $\dot{x} = f(x)$, are well known: see, *e.g.*, (Hahn, 1967, Theorem 26.3), (Hahn, 1963, Theorem 4.3), (Khalil, 2002, Theorem 4.2). As pointed out in these references, the original statement, as well as its converse, were firstly presented in Barbashin and Krasovskii (1952). The following excerpt is translated from p. 454:

Theorem 1. If there exists a positively definite, infinitely large function $v(x_1, x_2, \dots, x_n)$ which has definitely negative derivative then [the] trivial solution of [the] system (1) is asymptotically stable for any initial perturbations.

Here, “for any initial perturbations” means “for any initial states in \mathbb{R}^n ”. Furthermore, in the notation of Barbashin and Krasovskii (1952) “system (1)” corresponds to the equation

$$\frac{dx_i}{dt} = X_i(x_1, x_2, \dots, x_n), \quad i = 1, 2, \dots, n.$$

where the functions X_i are assumed to be continuously differentiable. Then, after Barbashin and Krasovskii (1952) [*sic*],

[...] a function $v(x_1, x_2, \dots, x_n)$ is called infinitely large if for any positive number A one can determine a constant N so large that for

$$\sum_{i=1}^n x_i^2 > N$$

we have that $v(x_1, x_2, \dots, x_n) > A$.

The following (equivalent) result appeared later in (La Salle and Lefschetz, 1961); see also (La Salle, 1960, Theorem 5), without any credit to Barbashin and Krasovskii (1952)¹²:

[Cited from (La Salle and Lefschetz, 1961, p. 67)]

IX. THEOREM. Let $V(x)$ be a scalar function with continuous first partial derivatives for all x . Suppose that: (i) $V(x) > 0$ for $x \neq 0$; (ii) $\dot{V}(x) < 0$ for $x \neq 0$; and (iii) $V(x) \rightarrow \infty$ as $|x| \rightarrow \infty$. Then the system [$\dot{x} = X(x)$, $X(0) = 0$] is completely stable.

The property that $V(x) \rightarrow \infty$, which Barbashin and Krasovskii referred to as being “infinitely large”, is better known as *properness* or *radial unboundedness* —*cf.* (Khalil, 2002, p. 123). Furthermore, in the latter the author discusses the importance of this property in order to conclude *global* results and reconsiders the Lyapunov func-

tion (4), proposed by Barbashin and Krasovskii (1952), whose level sets are illustrated in Figure 1.

Another fundamental contribution made by Barbashin and Krasovskii (1952) is “La Salle’s” stability theorem.

5.1 On “La Salle’s” theorem

The conditions of (Barbashin and Krasovskii, 1952, Theorem 1), for global asymptotic stability, are hard to meet in a number of particular applications. Specifically, finding a Lyapunov function with a negative definite derivative is in general a rather difficult task. La Salle (1960) published a few theorems for asymptotic stability for the case when one does not know a Lyapunov function with a negative definite derivative. The following statement, on attractivity of an invariant set, appears in La Salle (1960) —see also (La Salle and Lefschetz, 1961, p. 8), (Rouche and Mawhin, 1980, p. 51):

[Cited from (La Salle, 1960, Theorem 3)] Let $V(x)$ be a scalar function with continuous first partials for all x . Assume that

- 1) $V(x) > 0$ for all $x \neq 0$
- 2) $\dot{V}(x) \leq 0$ for all x .

Let E be the set of all points where $\dot{V}(x) = 0$, and let M be the largest invariant set contained in E . Then every solution of (2) [$\dot{x} = X(x)$] bounded for $t \geq 0$ approaches M as $t \rightarrow \infty$.

Let us consider the particular case that $M = \{0\}$. Then, although the previous statement guarantees the attractivity of the origin, it is direct to conclude asymptotic stability. Lyapunov stability follows (according to (Lyapunov, 1947, THEOREM I)) in view of the condition $\dot{V}(x) \leq 0$. If, in addition, we impose that V is radially unbounded, according to Barbashin and Krasovskii (1952), the property is global. This was established in (Barbashin and Krasovskii, 1952)[*sic*]:

Theorem 4. Let there exist an infinitely large definitely positive function $v(x_1, x_2, \dots, x_n)$ and a set M such that

$$\frac{dv}{dt} < 0 \quad \text{not in } M; \quad \frac{dv}{dt} \leq 0 \quad \text{in } M.$$

Let the set M have the property that on any intersection of the set $v = c$ ($c \neq 0$) and M there does not exist positive semi-trajectories of [the] system. We state, that the trivial solution $x_i = 0$ of system (1) [$\frac{dx_i}{dt} = X_i(x_1, x_2, \dots, x_n)$, $i = 1, 2, \dots, n$] is asymptotically stable for any initial perturbations.

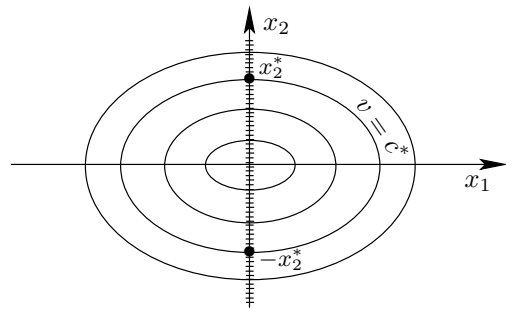

Fig. 2. Illustration of (Barbashin and Krasovskii, 1952, Theorem 4)

¹²The striking similarity in the notation used in these references can hardly be overlooked ...

For the sake of illustration let us consider a second-order autonomous system. Assume that there exists a positive definite, radially unbounded (infinitely large) function $v(x_1, x_2)$ some of whose level curves are showed in Figure 2. Furthermore, assume that there exists a continuous function $x_1 \mapsto w$ such that $w(0) = 0$, $w(x_1) < 0$ for all $x_1 \neq 0$ and

$$\frac{dv}{dt} = \frac{\partial v}{\partial x_1} X_1(x_1, x_2) + \frac{\partial v}{\partial x_2} X_2(x_1, x_2) = -w(x_1).$$

To apply (Barbashin and Krasovskii, 1952, Theorem 4) recalled above, we see that the set $\{x_1 = 0, x_2 \in \mathbb{R}\}$, *i.e.* the vertical axis of the phase space representation, and any subset of it qualifies as the set M . The intersections of $v = c$ (naturally for a small number of c s) with the vertical axis is represented in Figure 2. According to the theorem we must verify that on *any* intersection of $\{v = c\}$ and M the only set that contains continuous positive semi-trajectories (*i.e.* functions $t \mapsto x$ with $t \geq 0$) is the origin. Therefore, the only reasonable choice of the set M as defined in Theorem 4 is $\{x_1 = 0, x_2 \in \mathbb{R}\}$ or equivalently, $\{\dot{v} = 0\}$. This means that global asymptotic stability follows if $\{x_2 = 0\}$ is the only solution of $\dot{x}_2 = X_2(0, x_2)$.

Extensions of (Barbashin and Krasovskii, 1952, Theorem 4) to the case of non-autonomous periodic systems have also been published. The first is probably also due to Krasovskii —see, *e.g.* (Krasovskii, 1963, Theorem 14.1).

6. UNIFORMITY

So far we have discussed the “well-known” concepts of stability, asymptotic stability and non-local versions of the latter, without making any distinction between autonomous and non-autonomous systems, $\dot{x} = f(t, x)$. For the latter, however, it is crucial to understand whether the properties of stability and convergence hold uniformly in the initial times t_0 .

According to a number of authors, the first to study this fundamental property was Persidskiĭ, in the early 1930s. Antosiewicz (1958) attributes it to Persidskiĭ (1946) while Rouche et al. (1977) attribute the definitions of uniform stability to Persidskiĭ (1933):

[Translated from (Persidskiĭ, 1946)]

Consider the differential equations

$$\frac{dx_s}{dt} = W_s(x_1, \dots, x_n, t) \quad (s = 1, \dots, n) \quad (1)$$

[...] If for any given numbers $\varepsilon > 0$ and $t_0 \geq 0$ there exists a number $r > 0$, such that any solution

$$x_1 = f_1(t), \dots, x_n = f_n(t)$$

of system (1) satisfying inequality

$$|f_1(t_0)|^2 + \dots + |f_n(t_0)|^2 < r^2,$$

will, for all finite values $t \geq t_0$, satisfy inequality

$$|f_1(t)|^2 + \dots + |f_n(t)|^2 < \varepsilon^2,$$

we will say that solution x_1, \dots, x_n of system (1) is stable; [...] in the case when for all values $t_0 \geq 0$ there exists a number r which is independent of t_0 we will say that stability is uniform [2].

The reference “[2]” that Persidskiĭ cites above is Persidskiĭ (1933). As for much of Lyapunov theory, Hahn greatly

contributed by unifying the notation with contrasting rigour¹³:

[Cited from (Hahn, 1963, p. 62)]

THEOREM 17.1: The equilibrium of differential equation (2.7) [$\dot{x} = f(x, t)$, $f(0, t) = 0$, $f \in E$] is uniformly stable if and only if there exists a function $\rho(r)$ with the following properties:

- (a) $\rho(r)$ is defined, continuous, and monotonically increasing in an interval $0 \leq r \leq r_1$;
- (b) $\rho(0) = 0$; the function ρ , therefore, belongs to the class K ;
- (c) the inequality

$$|p(t, x_0, t_0)| \leq \rho(|x_0|)$$

is valid for $|x_0| < r_1$.

In Hahn’s characterization of uniform stability the function ρ is independent of the initial conditions, specifically, it is independent of t_0 . Then, the author attributes the following result to Persidskiĭ (1937):

[Cited from Hahn (1963)]

THEOREM 17.6 If there exists a positive definite decreasing Lyapunov function v such that its total derivative \dot{v} for (2.7) is negative semi-definite, then the equilibrium is stable.

Many authors attribute *uniform stability* to Persidskiĭ, who also provided a converse result (Persidskiĭ, 1937). Although no formal statement is given in this reference, sufficiency is also attributed to it by Rouche et al. (1977); Antosiewicz (1958) cites Persidskiĭ (1946). In other texts, following Hahn’s book, uniform stability is defined as follows —*cf.* (Vidyasagar, 1993, p. 137), (Rouche et al., 1977, p. 7), (Antosiewicz, 1958, p. 143), (Khalil, 2002, Definition 4.4., p. 149):

Definition 8. (Uniform stability). The origin of the system (1) is said to be uniformly stable if for each $\varepsilon > 0$ there exists $\delta(\varepsilon) > 0$ such that

$$|x_0| \leq \delta \implies |x(t, t_0, x_0)| \leq \varepsilon$$

for all $t \geq t_0$ and all $t_0 \geq 0$.

6.1 Uniform Global Stability

For non-autonomous systems it is important to distinguish whether uniform stability holds locally or in a *given* region. Specially, if we are interested in that it hold *in the whole* Euclidean space:

[Cited from (Hahn, 1963, p. 62)]

DEFINITION 17.2: The equilibrium of (2.7) is said to be uniformly stable in the whole if the assumption of Theorem 17.1 are satisfied for every arbitrarily large r_1 .

It is shown by Hahn that uniform stability in the whole is equivalent to the existence of a class \mathcal{K}_∞ function φ , independent of t_0 , such that (2) holds. In fact, uniform stability in the whole, also known as uniform *global* stability, comprises two essential and independent properties:

- (local) uniform stability.
- uniform global boundedness (uniform global La-grange stability)

¹³We remind the reader that in Hahn’s notation $p(t, x_0, t_0)$ corresponds to the solution of the differential equation $\dot{x} = f(x, t)$ and $f \in E$ if f is such that the solutions of $\dot{x} = f(x, t)$ are unique and continuous in the initial conditions.

The first is a local property while the second implies that the overshoot of the norm of the solutions has an upper-limit independent of the initial time, t_0 .

Even though the concept of uniform global stability has been used implicitly at least, from the 1950s by Soviet and Western authors, an explicit definition remains absent in recent English texts, such as: Vidyasagar (1993); Khalil (1992, 1996, 2002); Rouche et al. (1977); Rouche and Mawhin (1980). It appears, however, in (Krstić et al., 1995, p. 490) [*sic*]:

Definition A.4 The equilibrium point $x = 0$ of (A.1) [$\dot{x} = f(x, t)$] is

- uniformly stable, if there exists a class \mathcal{K} function $\gamma(\cdot)$ and a positive constant c independent of t_0 , such that

$$|x(t)| \leq \gamma(|x(t_0)|), \forall t \geq t_0, \forall x(t_0) |x(t_0)| < c; \quad (\text{A.3})$$

- globally uniformly stable, if (A.3) is satisfied with $\gamma \in \mathcal{K}_\infty$ for any initial state $x(t_0)$;

Relative to Definition 8, uniform global stability is tantamount to the property that $\varepsilon \mapsto \delta$ is globally invertible and independent of t_0 .

6.2 Uniform Asymptotic Stability

Similarly to asymptotic stability, which consists in the dichotomy of the two properties: stability and attractivity, in plain words, we say that the origin is uniformly asymptotically stable if it is both uniformly stable and uniformly attractive. Uniformity is to be understood with respect to the initial states and initial times and for both properties. The many other combinations (*e.g.* uniform stability plus (non-uniform) attractivity, *etc.*) have also received some attention in the literature, Antosiewicz (1958) collects nine different definitions.

Uniform asymptotic stability appears in different articles by I. G. Malkin between 1940 and 1955 in the context of stability with respect to *constantly-acting disturbances*, also known today as *total stability* or local input-to-state stability. It is also widely discussed in (Krasovskii, 1963), which appeared in English well after the author had introduced these concepts in Soviet literature:

[Cited from Hahn (1963)]

DEFINITION 17.4 (Malkin [20]): The equilibrium of (2.7) is called uniformly asymptotically stable if

- (1) the equilibrium is uniformly stable
- (2) for every $\epsilon > 0$ a number $\tau = \tau(\epsilon)$ depending only on ϵ , but not on the initial instant t_0 can be determined such that the inequality

$$|p(t, x_0, t_0)| < \epsilon \quad (t > t_0 + \tau)$$

holds, provided x_0 belongs to a spherical domain \mathfrak{R}_η whose radius η is independent of ϵ .

Interestingly, Hahn attributes this definition to the paper Malkin (1954) on stability with respect to constantly-acting perturbations; however, no precise formulation of uniform asymptotic stability is given in Malkin (1954). The second property in (Hahn, 1963, Definition 17.4) is often referred to as *uniform attractivity*¹⁴ —*cf.* (Rouche et al., 1977, p. 8), of which the following interesting characterisation is probably due to Hahn:

¹⁴Hahn uses the terminology *uniformly attracting* as a qualifier for the equilibrium.

[Cited from (Hahn, 1963, p. 64)]

THEOREM 17.3: Necessary and sufficient for the second condition of Definition 17.4 is the existence of a function $\sigma(r)$ with the following properties:

- (a) $\sigma(r)$ is defined, continuous, and monotonically decreasing, for all $r \geq 0$,
- (b) $\lim_{r \rightarrow \infty} \sigma(r) = 0$,
- (c) provided the initial points belong to a fixed spherical domain \mathfrak{R}_η , the relation

$$|p(t, x_0, t_0)| \leq \sigma(t - t_0) \quad (\text{17.6})$$

holds.

Further, the following characterization of uniform asymptotic stability is also established by Hahn:

[Cited from (Hahn, 1963, p. 64)]

THEOREM 17.4: Necessary and sufficient for uniform asymptotic stability of the equilibrium is the existence of two functions $\kappa(r)$ and $\vartheta(r)$ with the following properties:

- (a) $\kappa(r)$ satisfies assumptions (a) and (b) of Theorem 17.1,
- (b) $\vartheta(r)$ satisfies the corresponding assumptions of Theorem 17.3;
- (c) in addition, the inequality

$$|p(t, x_0, t_0)| \leq \kappa(|x_0|)\sigma(t - t_0) \quad (\text{17.7})$$

holds, provided that the initial points x_0 belong to a fixed spherical domain \mathfrak{R}_η .

The following statement, which Krasovskii (1963) attributes to Barbashin and Krasovskii (1952), Barbashin and Krasovskii (1954), gives sufficient conditions for the general notion of uniform asymptotic stability in the large. If the region of stability is reduced to a neighbourhood of the origin, we recover uniform asymptotic stability; if the domain of attraction corresponds to all of the Euclidean space, we obtain the notion of uniform asymptotic stability in the whole (Barbashin and Krasovskii, 1954).

[Cited from (Krasovskii, 1963, 30)]

DEFINITION 5.3. The null solution $x = 0$ is called uniformly asymptotically stable in the large in the region G if for arbitrary preassigned positive $\eta > 0$ and arbitrary $H_0, \bar{H}_0 \subset G$, there are always a number $T(H_0, \eta)$ and a bounded region $H_1, \bar{H}_1 \subset G$ such that the relations

$$x(x_0, t_0, t) \in H_1 \quad \text{for all } t \geq t_0,$$

$$\|x(x_0, t_0, t)\|_2 < \eta \quad \text{for all } t \geq t_0 + T(H_0, \eta),$$

hold for every initial moment of time t_0 and for every given value of $x_0 \in H_0$.

A sufficient condition for asymptotic stability in the large is the following.

THEOREM 5.2. The null solution $x = 0$ of equations (1.3) [*cf.* p. 6] is asymptotically stable in the large in the region G if there exists a function $v(x, t)$ such that

- (i) $v(x, t)$ is positive definite in G
- (ii) $v(x, t)$ admits an infinitely small upper bound in G ;
- (iii) $v(x, t)$ admits an infinitely great lower bound on the boundary of G [$v(x, t)$ is radially unbounded in G];
- (iv) The derivative dv/dt along a trajectory of (1.3) is negative-definite in G .

According to Krasovskii (1963) [*sic*] “The theorem is incorrect without the assumption (iii); a counter-example appears in [16]”. For the sake of clarity, it seems important to stress, however, that “[16]” here refers to Barbashin and Krasovskii (1952) which deals with asymptotic stability in the whole of *autonomous* systems (*i.e.*, uniformity is obtained for free) and therefore, the counter-example refers to the case when $v(x, t)$ is not radially unbounded on \mathbb{R}^n ; in this case, one is led to conclude asymptotic stability in the large and not asymptotic stability in the whole. As we pointed out above, for the sake of argument, Barbashin and Krasovskii (1952) use the counterexample illustrated by Figure 1, which is also discussed in all three editions of Khalil (1992, 1996, 2002).

This brings us back to the discussion on the distinction between asymptotic stability in the *large* and in the *whole*. The importance of this difference cannot be overestimated. Uniform asymptotic stability in the whole is the strongest stability property one may have for the equilibrium of non-autonomous differential equations (1). It was originally introduced in Barbashin and Krasovskii (1954) [*sic*]:

[Translated from (Barbashin and Krasovskii, 1954, p. 346)]: We call the solution $x_1 = \dots = x_n = 0$ of system (1)

$$\left[\frac{dx_i}{dt} = X_i(x_1, \dots, x_n, t) \quad (i = 1, \dots, n) \quad (1) \right]$$

uniformly stable in the whole, if for any numbers $R_1 > 0$ and $R_2 > 0$ one can find a number $T(R_1, R_2)$, depending continuously only on R_1 and R_2 , such that, any solution $x_i(x_{10}, \dots, x_{n0}, \tau_0, t)$ ($i = 1, \dots, n$) with initial values for $t = \tau_0 \geq t_0$ laying in the region

$$x_{10}^2 + \dots + x_{n0}^2 \leq R_1^2,$$

satisfies inequality

$$x_1^2 + \dots + x_n^2 < R_2^2 \quad \text{for } \tau_0 + T(R_1, R_2)$$

and at same time for any number $R_1 > 0$ there exists a number $R_2 = F(R_1)$, depending continuously only on R_1 , such that any trajectory starting from the interior of a sphere of radius R_1 does not escape from a sphere of radius R_2 as time passes.

Note that the definition has two parts, one which describes the property of uniform global attractivity and another which describes uniform global boundedness. Indeed, even if it is not made explicit in the paper that the function F is radially unbounded, this may be tacitly understood. In other words,

$$\forall \delta > 0, \exists \varepsilon > 0 : |x(t, t_0, x_0)| \leq \varepsilon$$

and, moreover, the function $\varepsilon \mapsto \delta$ is a *globally* bijective map. Only in this case, the function κ in (Hahn, 1967, Ineq. (17.7)) above is of class \mathcal{K}_∞ . This property is ensured by item (iii) in (Krasovskii, 1963, THEOREM 5.2) without which, as the author warns us, would be incorrect.

It may also be noted that the definition of Barbashin and Krasovskii (1954) does not explicitly mention the property of uniform Lyapunov stability but this is apparent from the context in that reference. The interpretation by Hahn (1963) of the definition of Barbashin and Krasovskii (1954), makes it clearer [*sic*]:

DEFINITION 17.5 (Barbašin and Krasovskii [2]): The equilibrium of the differential equation (2.7) is said to

be *uniformly asymptotically stable in the whole*, if the following two definitions are satisfied:

- (a) The equilibrium is uniformly stable in the whole;
- (b) for any two numbers $\delta_1 > 0$ and $\delta_2 > 0$ there exists a number $\tau(\delta_1, \delta_2)$ such that

$$|p(t, x_0, t_0)| < \delta_2$$

if $t \geq t_0 + \tau(\delta_1, \delta_2)$ and $x_0 < \delta_2$.

Item (a) unequivocally comprises the two properties of uniform stability and uniform global boundedness. Yet, for many years uniform global asymptotic stability has been defined as the combination of (only) the two properties¹⁵: uniform stability and uniform global attractivity that is, the property (b) in (Hahn, 1963, DEFINITION 17.5). For non-autonomous systems, however, such definition is incomplete because there is no guarantee that during the transient (for all $t \in [t_0, t_0 + \tau]$), the solution’s norm $|p(t)|$ does not grow to a limit that increases with t_0 . In other words, only in the case that $\rho(\cdot)$ in (Hahn, 1963, THEOREM 17.1) is of class \mathcal{K}_∞ , the converse of (Krasovskii, 1963, THEOREM 5.2) is valid for the global case (for all $x_0 \in \mathbb{R}^n$). Teel and Zaccarian (2006) warns us against this repeated mistake in the literature, rectified *e.g.*, in (Khalil, 2002, p. 150), where a definition equivalent to the following is given.

Definition 9. The origin of the system (1) is uniformly globally asymptotically stable if there exists $\varphi \in \mathcal{K}_\infty$ (independent of t_0) such that $|x(t, t_0, x_0)| \leq \varphi(|x_0|)$ for all $t \geq t_0$ and, for any pair $r > 0$ and $\sigma > 0$, there exists $T(\sigma, r) > 0$ such that, for all $t_0 \geq 0$,

$$|x_0| \leq r \implies |x(t, t_0, x_0)| \leq \sigma \quad \forall t \geq t_0 + T.$$

7. CONCLUSIONS

Lyapunov stability theory is one of the undisputed pillars of control theory, as we know it today. However, it is inevitable that the milestone concepts developed through more than a century are miss-translated and miss-transcribed from text to text. One shall not keep rigour, however, to the authors who, in their *bona fide* pedagogical endeavor, transmitted these concepts to succeeding generations. This being said, let us recall the reader that:

“Des lecteurs attentifs, qui se communiquent leurs pensées, vont toujours plus loin que l’auteur”

—Voltaire, “*Traité sur la tolérance*” 1763.

REFERENCES¹⁶

- *Aizerman, M.A. (1952). *Теория автоматического регулирования двигателей*. Gostehiszdad, Moscow. English title (as cited by W. Hahn): *Theory of automatic control of motors*.
- Antosiewicz, H.A. (1958). *Contributions to the theory of nonlinear oscillations*, volume IV, chapter VIII. A survey on Lyapunov’s second method, 141–166. Princeton University Press, Princeton. Edited by S. Lefschetz.
- Bacciotti, A. and Rosier, L. (2001). *Liapunov Functions and stability theory*, volume 267 of *Lecture notes in control and information sciences*. Springer Verlag.

¹⁵See *e.g.*, (Rouche et al., 1977, p.10), although in the latter reference the authors attribute this definition to Barbashin and Krasovskii (1952) which concerns only autonomous systems, (Bacciotti and Rosier, 2001, Definition 3.6, p.80), (Vidyasagar, 1993, Definition 5.1.38, p.143), (Khalil, 1996, p. 135).

¹⁶The refences preceded by a * correspond to those that we were not able to consult personally when writing this survey.

- Barbashin, E.A. and Krasovskii, N.N. (1952). Об устойчивости движения в целом. *Dokl. Akad. Nauk. USSR*, 86(3), 453–456. Commonly (and wrongly) cited in English under: “On the stability of motion in the large”; Correct translation: “On the stability of motion in the whole”.
- Barbashin, E.A. and Krasovskii, N.N. (1954). О существовании функций Ляпунова в случае асимптотической устойчивости в целом. *Prikl. Mat. i Mekh.*, 18, 345–350. Commonly (and wrongly) cited in English under: “On the existence of Lyapunov functions in the case of asymptotic stability in the large”. Appropriate translation: “On the existence of Lyapunov functions in the case of asymptotic stability in the whole”.
- *de la Grange, J.L. (1788). *Mécanique Analytique*. Chez la veuve DESAINT, Paris, 1ère edition. Avec approbation et privilège du Roi, M. DCC. LXXXVIII. (In French).
- Fursov, V.D. (1977). Устойчивость движения, оценки и стабилизация. Nauka, Moscow. Translated title: Stability of motion, estimates and stabilization.
- Goldstein, H. (1974). *Classical Mechanics*. Addison Wesley.
- Hahn, W. (1963). *Theory and Application of Liapunov's Direct Method*. Prentice Hall, New York.
- Hahn, W. (1967). *Stability of motion*. Springer-Verlag, New York.
- Khalil, H. (1992). *Nonlinear systems*. Macmillan Publishing Co., 1st ed., New York.
- Khalil, H. (1996). *Nonlinear systems*. Macmillan Publishing Co., 2nd ed., New York.
- Khalil, H. (2002). *Nonlinear systems*. Prentice Hall, 3rd ed., New York.
- Krasovskii, N.N. (1954). О поведении в целом интегральных кривых системы двух дифференциальных уравнений. *Prikl. Mat. i Mekh.*, 18, 149–154. English title: On the behaviour in the large of integral curves of a system of two differential equations. Better translation: On the behaviour in the whole
- Krasovskii, N.N. (1963). *Problems of the theory of stability of motion*. Stanford Univ. Press. Translation of Russian edition, Moscow 1959.
- Krstić, M., Kanellakopoulos, I., and Kokotović, P. (1995). *Nonlinear and Adaptive control design*. John Wiley & Sons, Inc., New York.
- La Salle, J.P. (1960). Some extensions of Liapunov's second method. *IRE Transactions on Circuits Theory*, CT-7(4), 520–527.
- La Salle, J.P. and Lefschetz, S. (1961). *Stability by Lyapunov's direct method*. Academic Press, New York.
- Lagrange, J.L. (1888). *Mécanique Analytique*. Gauthier-Villars et fils, Paris, 4ème edition. Publiée par Gaston Darboux. Includes the papers by Dirichlet and Poisson. (In French).
- Lejeune-Dirichlet, G. (1888). *Sur la stabilité de l'équilibre*, chapter in *Mécanique Analytique* de J.-L. Lagrange – Note II., p. 457 du Tome Premier. Gauthier-Villars et fils. (In French).
- Loría A. and Panteley, E. (2006). Stability, told by its developers, chapter in *Advanced topics in control systems theory*, pp. 199–255, volume 328 of Lecture Notes in Control and Information Sciences, A. Loría, F. Lamnabhi-Lagarigue, E. Panteley, eds. Springer Verlag, London.
- *Lyapunov, A.M. (1892). Общая задача об устойчивости движения. *Сообщения Харьковского Математического Общества*. English title: *The general problem of the stability of motion*. Communications of the Mathematical Society of Kharkov.
- Lyapunov, A.M. (1947). *Problème général de la stabilité de mouvement*, volume 17 of *Ann. math. Studies*. University Press, Princeton. Facsimile reprint of the translation in French of (Lyapunov 1892), first published in 1907.
- Malkin, I.G. (1954). К вопросу об обратимости теоремы Ляпунова об асимптотической устойчивости. *Prikl. Mat. i Mekh.*, 18, 129–138. (In Russian). Usually cited in English as: *On the reciprocal of Lyapunov's theorem on asymptotic stability*.
- Mawhin, J. (1994). The centennial legacy of Poincaré and Lyapunov in ordinary differential equations. *Supplemento ai Rendiconti dei Circolo Matematico di Palermo*, II(34), 9–46.
- Mawhin, J. (2005). Alexandr Mikhailovich Lyapunov, Thesis on the stability of Motion 1892, chapter in *Landmark Writings in Western Mathematics 1640–1940*. Elsevier. Edited by I. Grattan-Guinness.
- Persidskii, K.P. (1933). Об устойчивости движения по первому приближению. *Mat. Sbornik*, 40(3), 284–293. English title: On the stability of motion in the first approximation.
- Persidskii, K.P. (1937). Об одной теореме Ляпунова. *Dokl. Akad. Nauk. USSR*, XIV(9), 541–543. English title: On a theorem by Lyapunov. Title also used: Über einen satz von Liapounoff.
- Persidskii, K.P. (1946). К теории устойчивости решений дифференциальных уравнений. *Успехи Математических Наук*, 1(5-6 (15-16)), 250–255. English title: On the theory of stability of solutions of differential equations –summary of doctoral (Sc.) dissertation.
- Poincaré, H. (1890). Sur le problème des trois corps et les équations de la dynamique. *Acta Mathematica*, 13, 5–266. (In French).
- *Poisson, S.D. (1838). *Traité de Mécanique*. Société belge de Librairie, Bruxelles. (In French).
- Rouche, N., Habets, P., and Laloy, M. (1977). *Stability theory by Liapunov's direct method*, volume 22 of *Appl. Math. Sc.* Springer-Verlag, New York.
- Rouche, N. and Mawhin, J. (1973). *Equations différentielles ordinaires, Tome 2: Stabilité et solutions périodiques*. Masson et C^{ie}, Paris. (In French).
- Rouche, N. and Mawhin, J. (1980). *Ordinary differential equations II: Stability and periodical solutions*. Pitman publishing Ltd., London. (In French).
- Rouche, N. and Peiffer, K. (1967). Le théorème de Lagrange-Dirichlet et la deuxième méthode de Lyapunoff. *Annales de la Société Scientifique de Bruxelles*, 81(I), 19–33. (In French).
- Slotine, J.J. and Li, W. (1987). On the adaptive control of robot manipulators. *Int. J. Robotics Res.*, 6, 49–59.
- Teel, A.R. and Zaccarian, L. (2006). On the literature's two different definitions of uniform global asymptotic stability for nonlinear systems, chapter in *Advanced topics in control systems theory*, pp. 285–289.
- Četaev, N.G. (1956). *Stability of motion*. Gostehisdat.
- Vidyasagar, M. (1993). *Nonlinear systems analysis*. Prentice Hall, New Jersey.