



HAL
open science

Graph-based analysis of resource dependencies in project networks Graph-Based Analysis of Resource Dependencies in Project Networks

Gurdal Ertek, Byung-Geun Choi, X. Chi, D Yang, Ong Boon Yong

► **To cite this version:**

Gurdal Ertek, Byung-Geun Choi, X. Chi, D Yang, Ong Boon Yong. Graph-based analysis of resource dependencies in project networks Graph-Based Analysis of Resource Dependencies in Project Networks. 2015 IEEE International Conference on Big Data (Big Data), Oct 2015, Santa Clara, United States. hal-01744358

HAL Id: hal-01744358

<https://hal.science/hal-01744358>

Submitted on 27 Mar 2018

HAL is a multi-disciplinary open access archive for the deposit and dissemination of scientific research documents, whether they are published or not. The documents may come from teaching and research institutions in France or abroad, or from public or private research centers.

L'archive ouverte pluridisciplinaire **HAL**, est destinée au dépôt et à la diffusion de documents scientifiques de niveau recherche, publiés ou non, émanant des établissements d'enseignement et de recherche français ou étrangers, des laboratoires publics ou privés.

Dr. Gürdal Ertek's Publications



Ertek, G., Choi, B.-G., Chi, X., Yang, D., Yong, O. B., "Graph-based analysis of resource dependencies in project networks". In Proceedings of 2015 IEEE International Conference on Big Data (Big Data). (2015) 2143 - 2149.

Note: This document the final draft version of this paper. Please cite this paper as above. You can download this final draft from the following websites:

<http://ertekprojects.com/gurdal-ertek-publications/>

The published paper can be accessed from the following short url:

bit.ly/1SbBk49

or the following URL:

<http://ieeexplore.ieee.org/xpl/articleDetails.jsp?arnumber=7363999&newsearch=true&queryText=gurdal%20ertek>

Graph-Based Analysis of Resource Dependencies in Project Networks

Gurdal Ertek

Rochester Institute of Technology - Dubai
Dubai Silicon Oasis,
Dubai, U.A.E.
gurdalertek@gmail.com

Byung-Geun Choi

Xu Chi
DaZhi Yang
Ong Boon Yong
Singapore Institute of Manufacturing Technology
Singapore
byung-geun.choi@epfl.ch
cxu@simtech.a-star.edu.sg
yangdz@simtech.a-star.edu.sg
ongby@simtech.a-star.edu.sg

Abstract— It is a challenge to visualize high dimensional data such as project data to yield new and interesting types of insights. To address this, we augment the traditional PERT network diagram with additional nodes that represent resources, and with arcs from the resource nodes to the activities that use those resources. Subsequently, we apply various graph layout algorithms that can reveal the hidden patterns in the graph data. Finally, we also map various attributes of the activities to the features of activity nodes. We illustrate the applicability and usefulness of our methodology through two case studies, where we visualize data from a benchmark data library and from the real world.

Keywords- project management; PERT; graph visualization; graph layout algorithm; information visualization.

I. INTRODUCTION

A *project* can be defined as “a temporary endeavor undertaken to create a unique product or service” and *project management* can be defined as the “application of knowledge, skills, tools, and techniques to project activities to meet project requirements” [1]. Industries where the production process is in the form of projects include aerospace, software, construction, and shipyard industries. The motivation for the presented research was a series of projects completed with the shipyard industry, and the research goal was to develop new planning tools for project management.

Shipyard (ship building and ship repair) industry is a competitive international industry in terms of not only price, but also quality and time-to-delivery. Achieving shorter project completion times (makespans) increases the competitiveness of a company. The project management systems in a typical shipyard pose several challenges (related to our research), most of which are also encountered in project management settings in other industries: (1) Current information technology (IT) systems exist as islands and are not integrated to connect, exchange, and analyze data. (2) Off-the-shelf software products and generic Enterprise

Resource Planning (ERP) systems are not specially tuned and customized for the needs of the industry, leaving many of the pain points unsolved. (3) Classic project management tools do not always support decision making to the required degree, making project management time-consuming and difficult. (4) Classic graphical tools of project management provide limited capability for insight generation. (5) There does not exist an insight-generation visual tool that illustrates resource dependencies in a project, before scheduling.

It is the goal of this paper to present a new visualization scheme that helps solve the above mentioned problems encountered in the shipyard industry, as well as other industries that operate on project basis. The presented visualization scheme was developed with a perspective of putting emphasis on the resources required to execute project tasks, and thus follows the same perspective as the Critical Chain Method (CCM) [2,3,4] and the theory of constraints [5,6,7].

Project management involves the coordination of the activities, resources, finances and information during the completion of a project. The project management literature contains several visual tools to help with this coordination. The most popular visual tools are the Gantt chart [8] and the PERT network diagram [9], illustrated in Figures 1 and 2, respectively. The Gantt chart visualizes the schedule of a project, illustrating which activity takes place over which time ranges. PERT network diagram, on the other hand, visualizes the precedence relations between activities, as well as other relevant data (in textual form) inside the activity nodes [10]. Typical information and data displayed inside a node of the PERT network diagram include the activity name, the activity duration early start time, early finish time, late start time, late finish time and the slack. Besides these two visualizations, another commonly applied visualization, namely the Resource Schedule Gantt chart [11], is a modified version of the Gantt chart, where the x-axis still shows time but the y-axis shows resources rather than tasks (Figure 3).

While all the mentioned visualizations are useful and highly popular in industry and academia, we initiated a research project for developing new visualization schemes that can illustrate resource dependencies to visually help with cognition and insight generation. This paper presents a particular scheme that has been developed to this end.

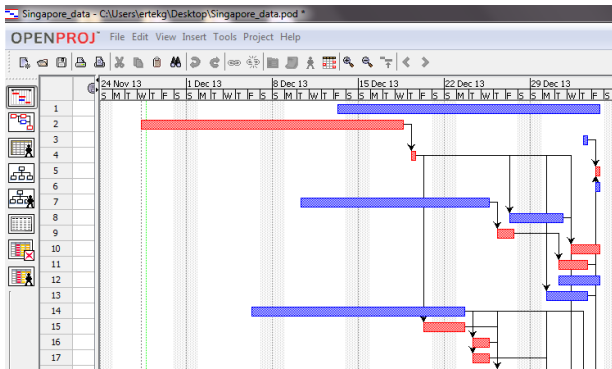

Figure 1. Gantt chart example.

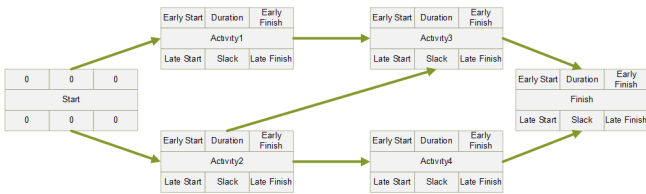

Figure 2. PERT network example.

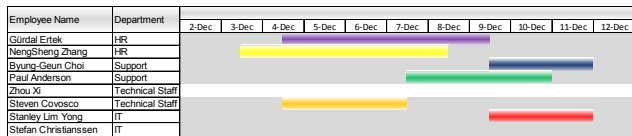

Figure 3. Resource Schedule Gantt chart example.

In project planning, it is important to respect the precedence relationships between the different activities. PERT network diagram readily allows for the representation of these precedence relations on a graph. Resources are also important in project planning and especially scheduling; the availability of the resources as well as the usages of the resources by the various activities can have a major impact on the project schedule. To this end, gaining available resources can be thought as virtual activities that precede the activities using those resources. Therefore, similar to the precedence relation between the activities in the PERT network diagram, precedence relations can be shown between resources of activities and the activities themselves. Following this line of thought, we represent resources as nodes of a new type (colored nodes with a new color) and draw arcs from the resources to the activities that use them.

Besides the three mentioned popular visualization techniques, there have been other academic studies of new visualization schemes that have been developed for project management summarized as follows.

Russell et al. [12] present a visualization scheme for change order (orders for change in the project) data, based on 3-dimensional (3D) bar-charts. They also thoroughly explain why and how visualizations can help with project management, with citations to both project management and information visualization literatures. They visualize change order data with 3D bar-charts, whereas we visualize project data with graphs. Zhang and Zhu [13] introduce an intelligent project scheduling system, namely Scheduling with a Vision (SWAV), which creates both schedules and visualizations. In the visualizations, the status of critical factors such as cash in- and outflows and resource utilizations are shown based on the schedule. While resource utilizations are also illustrated in our study, the visualization in [13] requires the generation of a schedule, which our study does not require. Chiu and Russell [14] illustrate various aspects of a project's schedule, such as the schedule itself, and planned vs. actual work, using linear planning (LP) chart views. We, in our paper, do not require a schedule and introduce graph-based visualizations. They also discuss the benefits of visualizing construction data, and includes a case study. Aguirregoitia et al. [15] use T-cube and metromap visualization schemes for visualizing software project data and compares the two schemes with respect to similarities and differences. Luz et al. [16] present Chronos, a tool for interactive scheduling and visualization of task hierarchies. The paper also successfully presents a review of visualization schemes similar to Gantt charts. Last but not the least, Songer et al. [17] visualize project control data, specifically cost data, and apply Charette testing to prove the effectiveness of the visualizations.

Our study contributes to the research community in three dimensions: First, we develop and present a new visualization scheme for showing resource dependencies in projects. Second, we list and illustrate the types of actionable insight that can be derived from using the proposed visualization scheme. Finally, we provide a proof of concept and exhibit the proposed scheme in two case studies.

The remainder of the paper is organized as follows: Section 2 discusses the methodology developed and applied in the study. Section 3 is devoted to the analysis and results of the first case study, where new insights are obtained for a well-known benchmarking dataset. Section 4 is devoted to the second case study, where real world data for a ship maintenance project is used. Finally, Section 5 presents some conclusive remarks, as well as possible future research avenues.

II. VISUALIZATION SCHEME

Visualization enables peoples to glean knowledge and deeper insight from large amounts of data. A new visualization scheme presented in this paper is an integration of three novelties to the classic PERT diagram: (1) adding resources as nodes and draw arcs from these resources to the activities using them, (2) applying readily available graph layout algorithms in visualizing the augmented project network, hereby revealing patterns and insights, and (3) mapping

various attributes of the activities to the nodes that represent those activities.

An appropriate existing hierarchical layout algorithm in a commercial software [18] is selected to minimize the crossings of the edges within the layers in our study. The hierarchical layout highlights the main direction or flow within a directed graph with the nodes being placed in hierarchically arranged layers [19, 20]. The ordering of the nodes within each layer is visualized in such a way that the number of arc crossings is small [21].

The final novelty in our visualization is the mapping of various attributes of the activities to the corresponding nodes in the graph visualization. Specifically, we map the duration of each activity to the width of the rectangular node representing that activity (Figures 4, 5, 6 and 7), and we map the cost of each activity linearly to the color of the corresponding node (Figure 7).

The types of insights that can be obtained through the introduced visualization scheme are listed in the case studies.

While it may seem as a limitation that our method deals with only somewhat hierarchical data, this actually is not a limitation, because project management data consists of tasks that are tied to each other in a precedence relationship. In other words, if a task a is a predecessor of another task b then task b can not be the predecessor of a .

III. CASE STUDY I: PSBLIB DATASET

Data

Our first case study involves the analysis of the data of a problem instance from a well-known dataset of benchmarking datasets from the project scheduling literature, namely PSBLIB [22, 23]. The problem instance that we have selected is `i309_9`, which contains 30 activities and 4 resources. The addition of the source and sink nodes results in a network with 32 activity nodes. The data for the problem instance was not rich enough to illustrate the type of insights that could be obtained using graph visualization. Therefore, we added six new resources and arcs associated with them. For these new six resources, we have created arcs to the activities with a probability of 0.5. The resulting visualization is given in Figure 4, and the insights obtained from this visualization will be explained next. The dataset and the visualizations can be downloaded from [24].

Visualization, Analysis and Insights

There are multiple types of insights that can be obtained from the graph visualization in Figure 4. The letters on the figure correspond to the insights that we list below:

Insight a: Frequently used resources.

Resources R1, R2, R3 and R4 the most frequently used resources in the project. These resources are used from the beginning of the project until the end and are needed by too

many activities, as can be observed by the many arcs that emanate from them. These resources should *not* be outsourced, but should be kept/stored in-house.

Insight b: Activities that use many resources and have many predecessors.

Certain activities require the usage of many resources, more in number than the remaining activities. While there are a multitude of such resources in our example, we specifically highlight activity 27. Activity 27 takes very little time but requires the usage of many resources. Furthermore, activity 27 has three predecessor activities, making it even harder to coordinate this activity. Another interesting observation that can be made about activity 27 is that it precedes activity 29, which is one of the four activities that connect to the sink node. This means that any inefficiency with respect to scheduling activity 27 will reflect on activity 29, and potentially on the makespan as well (we do not know at this point whether activities 27 and 29 are on the critical path or not). It would not be easy to read all these comparative information without such a visualization scheme.

Insight c: Activities that depend on many other activities

Activity 29 needs four other activities to be completed before it can start. This can be observed through the number of black arcs (arcs between activities) that terminate at activity 29.

Insight d: Activities that use many resources.

Activities 5, 6 and 16 use multiple resources, making them harder to schedule, since their respective required resources need to be available at the same time for any of these activities to be started.

Insight e: Less frequently used resources

Certain resources are not used by many activities. Resources R5, R6, R7, R8, R9 and R10 are such resources. We can tell this by observing the number of arcs that emanate from each of these resources. Since these resources are not needed frequently throughout the project, they can be leased, rented or hired, also depending on other factors such as cost of ownership, maintenance cost and cost of outsourcing. Our proposed visualization scheme allows us to identify such resources and potentially save on the project costs. In general, two rules of thumb for identifying such resources are the following: If the resource node has a low out degree value (few nodes emanating from it) and if the resource node is positioned outside the general cluster of the nodes, then resource can be potentially outsourced.

A second visualization, namely graph visualization with organic layout, can provide and confirm insights and e of Figure 4. In this visualization, the layout is again computed to minimize the number of arc crossings, but this time in a non-hierarchical manner. As can be observed in Figure 5,

resources R1, R2, R3 and R4 are the central to the project. They are involved with many activities throughout the project. Other resources, on the contrary, are used in very

few activities, and can be considered for being supplied from the outsource companies. It should be noticed that the arcs between the activities are omitted in the graph of Figure 5.

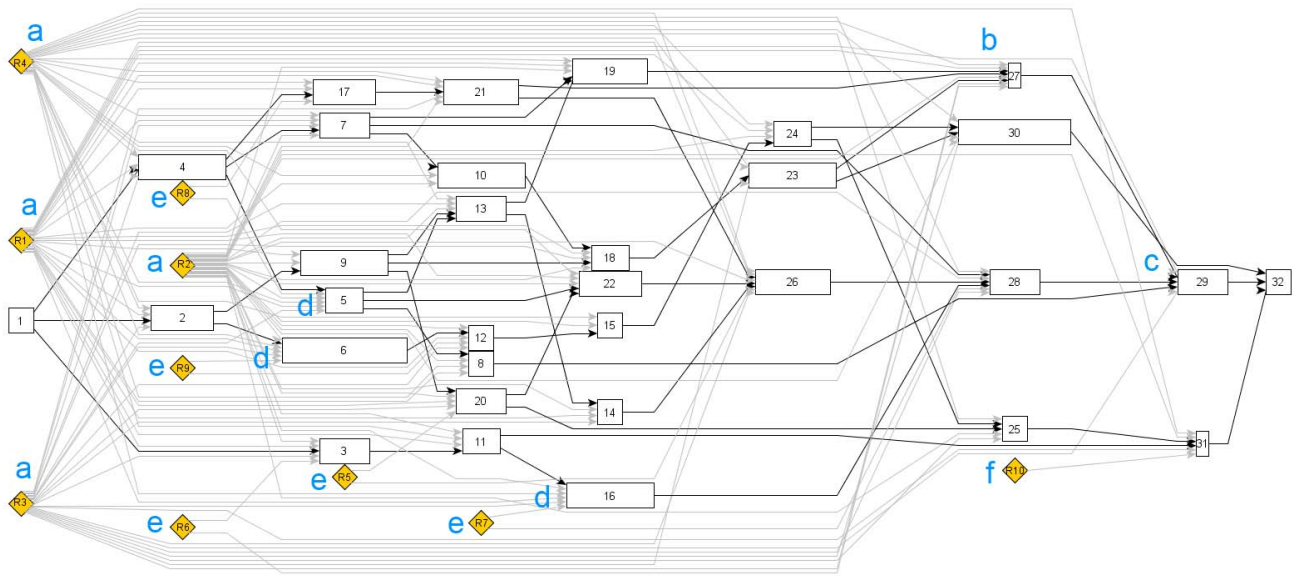

Figure 4. Hierarchical layout for Case Study I.

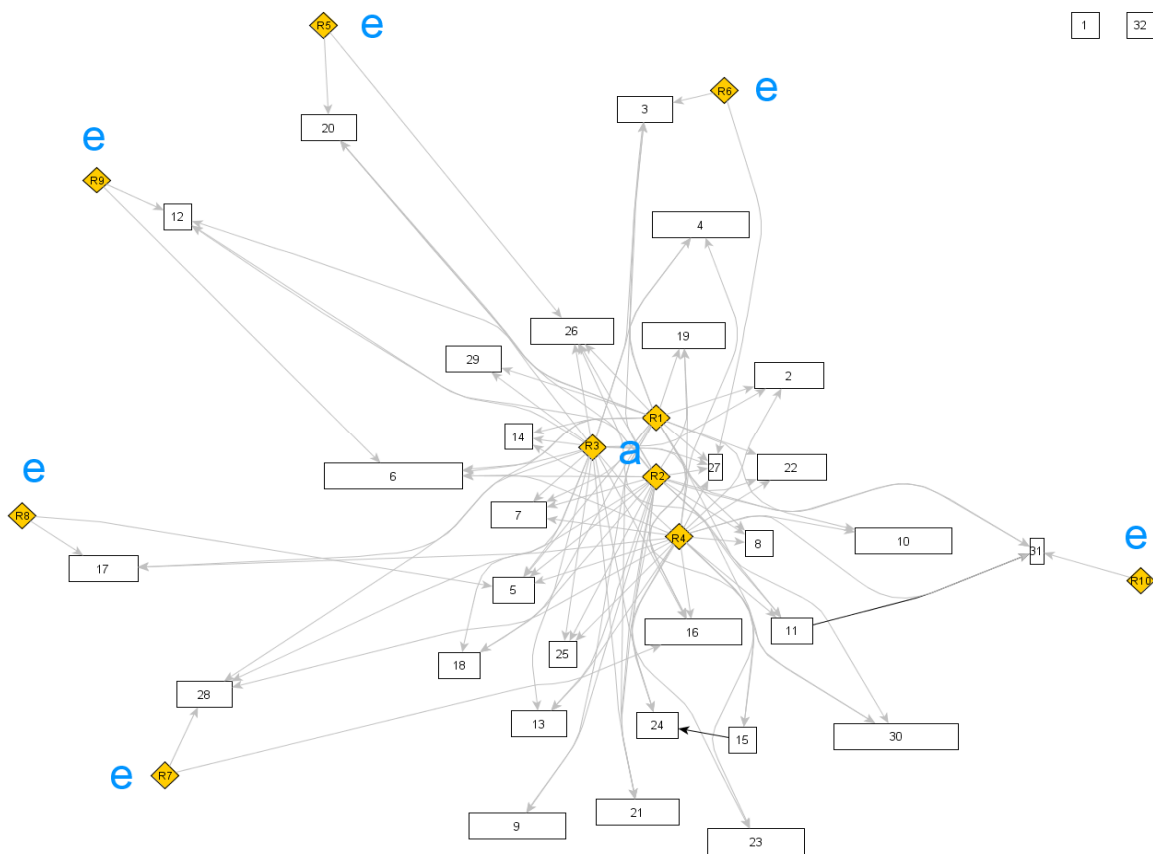

Figure 5. Organic layout for Case Study I.

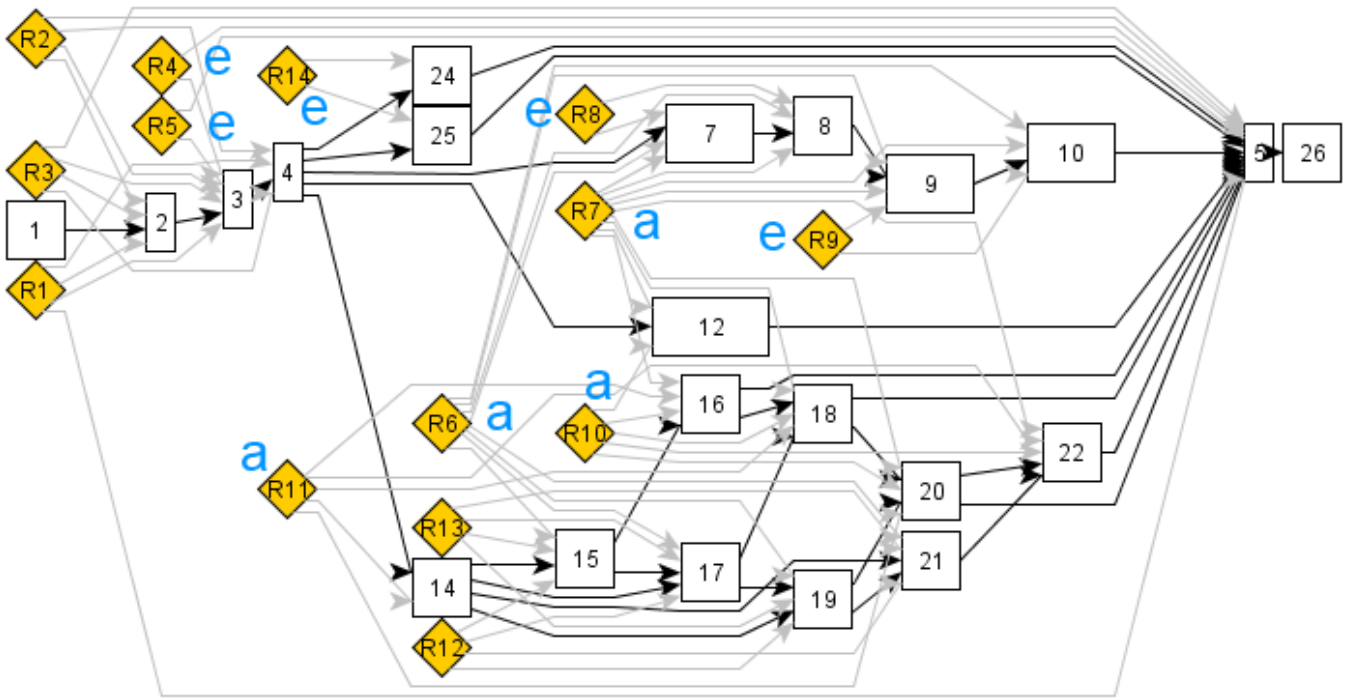

Figure 6. Hierarchical layout for Case Study II.

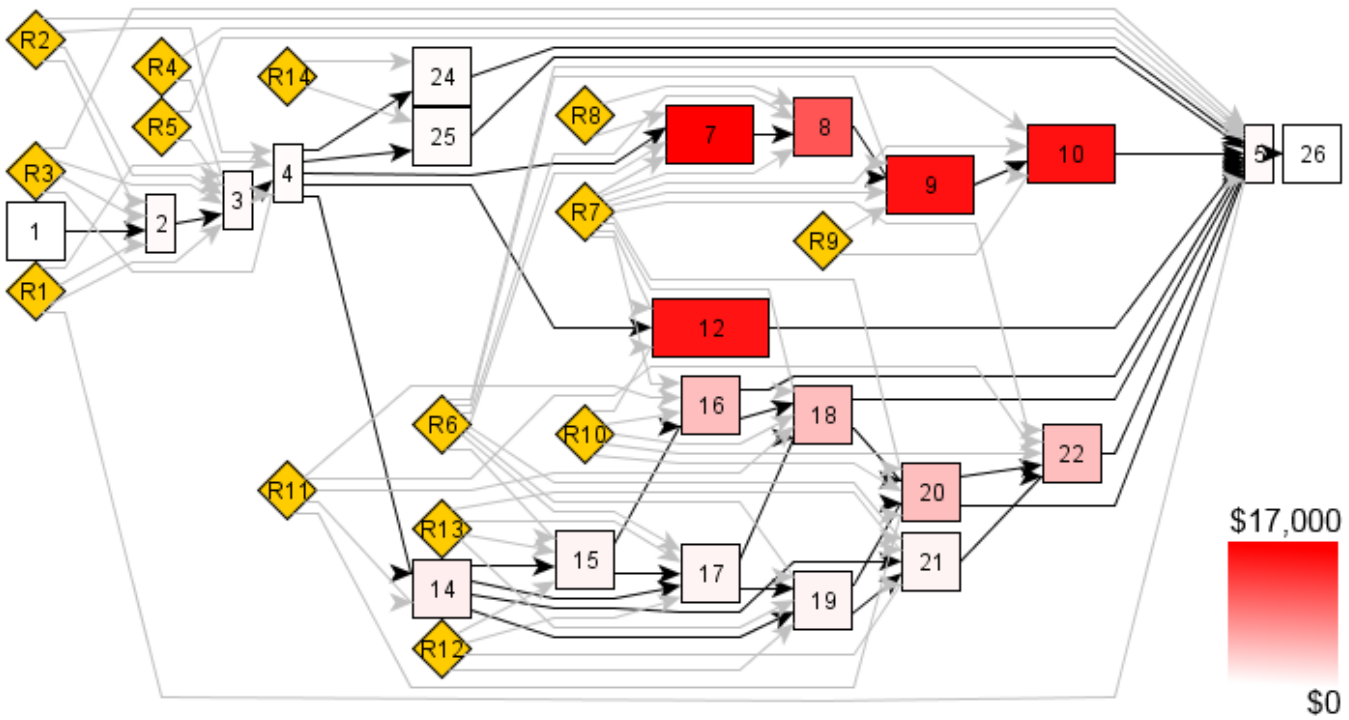

Figure 7. Hierarchical layout for Case Study II, with the activity costs being mapped to the color of the activity nodes.

IV. CASE STUDY II: SHIPBUILDING PROJECT DATASET

Data

The second case study uses masked and distorted real world data from the shipyard industry, one of the largest industries in Singapore (Figure 6). The activities and resources of the project, as well as precedence relationships, are given in Tables 1 and 2. This particular project describes a maintenance project at a shipyard. The dataset and the visualizations can be downloaded from [24].

Visualization, Analysis and Insights

The considered project contains 20 activities at level 2. The numbers in Figure 6 for the activities have a range between 2 and 25 because some of numbers denote activities at level 1. The same type of insight as in case study 1 can be observed for case study 2 in Figure 6. Resources R6, R7, R10 and R11 each have more than five arcs emanating from them, indicating the importance and centrality of these resources. Resources R4, R5, R8, R9 and R14, on the other hand, have only two arcs emanating from them, denoting that not as many activities depend on these resources. Other insights, illustrated Case Study I, can also be seen through careful observation.

TABLE I. ACTIVITIES IN CASE STUDY II

ID	Name	Predecessors
2	Set Keel Blocks into Position	
3	Tow vessel into drydock	2
4	Empty drydock	3
5	Undocking	10;12;16;18;20;22;24;25
7	High Pressure Washing	4
8	Grit Blasting	7
9	Painting (epoxy polyimide paint)	8
10	Painting (vinyl anti-fouling)	9
12	Renew zinc anodes	4
14	Remove Starboardside Sheet Plates	4
15	Cut Starboardside Sheet Plate 1	14
16	Weld Starboardside Sheet Plate 1	15
17	Cut Starboardside Sheet Plate 2	14;15
18	Weld Starboardside Sheet Plate 2	17;16
19	Cut Starboardside Sheet Plate 3	14;17
20	Weld Starboardside Sheet Plate 3	19;18
21	Cut Starboardside Sheet Plate 4	14;19
22	Weld Starboardside Sheet Plate 4	21;20
24	Empty Ballast Waste	4
25	Replace Ballast Water	4

The final visualization of the paper is given in Figure 7, and adds a new dimension to the visualization in Figure 6. This time, the cost of each activity is linearly mapped to the color of the node representing that activity. A certain group of activities, namely activities 7, 8, 9, 10 and 12, have significantly higher costs compared to other activities. It is also peculiar that these activities are grouped together, suggesting that they have connection with similar nodes. A

careful observation shows that all of these expensive activities depend on resources R6, R7, R8 and R9. It is highly likely that these activities are expensive due to all in relation with the cost of the resources they use. It is particularly interesting to see that resource R9 is used in activities 9 and 10, both very expensive activities. In our earlier analysis, due to the fact that R9 has only two arcs emanating from it, we had identified R9 as a candidate resource for outsourcing. However, our new analysis based on Figure 7 shows that this resource is used in two expensive activities and is thus highly important. This shows that our analysis of the graph visualization should be enriched by mapping other relevant attributes to the visualization. We project that the highlighting of the critical path of the project can also contribute to our understanding of the role of resources in the project.

One shortcoming of our visualization scheme is that it is for visualizing only for single-project data. Our experiments with the visualization of real-world multi-project data using this scheme did not produce easily accessible insights.

TABLE II. RESOURCES IN CASE STUDY II

Resource Number	Resource Name
R1	Dock Master
R2	Drydock
R3	Dock Engineer
R4	Rigger
R5	Pilot Tugs
R6	SubContractor
R7	Crane
R8	Blaster
R9	Painter
R10	Welder
R11	Fitter
R12	Steel Cutter
R13	Cutter
R14	General Worker

V. CONCLUSIONS AND FUTURE WORK

In this paper, we have presented a new visualization scheme for displaying project data including resources, to yield new and interesting types of insights. The proposed visualization scheme can be easily implemented using readily available graph visualization algorithms and software for visualizing a well-known graph type in the project management literature. While the usages of graph visualization have been introduced before [1], our paper brought three novel contributions: First, we introduced resources into the graph as a set of new nodes (with a different color), hence transforming the PERT project diagram into a colored graph. To the best of our knowledge, this is the first time that activities and resources are displayed together using a graph layout algorithm. Second, we outlined and described the different types of actionable insights that can be obtained

through these visualizations. Finally, we illustrated the applicability and usefulness of our proposed visualization scheme through two case studies, one coming from a benchmarked dataset in the project scheduling literature, and the other coming from the real world.

In summary, we have provided practitioners and researchers working in the field of project management with a new visual tool for planning. Future research in this area can explore how our visualization scheme can be adapted for multi-project management through the enrichment of the visualization by extending it into three dimensions to visualize multi-project data by adopting the proposed method, or by developing new methods. Other possible future research includes further development of the visualization scheme into a visual data mining tool as the field of visual data mining will continue to grow at an even faster pace in the future.

REFERENCES

- [1] Project Management Institute, "A Guide To The Project Management Body Of Knowledge (3rd ed. ed.)," Project Management Institute, 2003.
- [2] H. P. Wang, B. N. Liu and X. F. Dong. "The Recognition and Optimization of the Critical Chain," In The 19th International Conference on Industrial Engineering and Engineering Management, pp. 385-391, Springer Berlin Heidelberg, 2013.
- [3] X. Wang, Y. Bai, C. Cai and X. Yan. "Application of resource-constrained project scheduling with a critical chain method on organizational project management," 2010 International Conference on Computer Design and Applications (ICCD), Vol. 2, pp. 51-54, 2010.
- [4] E. M. Goldratt. Critical chain. Great Barrington, MA: The North River Press. 1998.
- [5] J. H. Blackstone Jr, J. F. Cox III and J. G. Schleier Jr. A tutorial on project management from a theory of constraints perspective. International Journal of Production Research, 47(24), 7029-7046. 2009.
- [6] Z. Tian, Z. Zhang and W. Peng. A critical chain based multi-project management plan scheduling method. In Industrial and Information Systems (IIS), 2010 2nd International Conference on (Vol. 2, pp. 304-308). IEEE. 2010.
- [7] S. H. Rhee, N. W. Cho and H. Bae. Increasing the efficiency of business processes using a theory of constraints. Information Systems Frontiers, 12(4), 443-455. 2010.
- [8] H. Gantt. "Organizing for work". *Industrial Management*, 58:89-93, 1919.
- [9] W. Fazar. "Program Evaluation and Review Technique". The American Statistician, Vol. 13, No. 2, p.10. April 1959.
- [10] J. Gido and J. P. Clements Successful Project Management. Cengage Learning. 2011.
- [11] Resource Schedule Gantt Chart. <http://technology.amis.nl/2013/02/16/adf-dvt-speed-date-meeting-the-gantt-charts/>. Accessed on November 30, 2013.
- [12] A.D. Russell, C.Y. Chiu and T. Korde. Visual representation of construction management data. Automation in Construction, 18(8), 1045-1062, 2009.
- [13] P. Zhang and D. Zhu. Information Visualization in Project Management and Scheduling, Proceedings of The 4th Conference of the International Society for Decision Support Systems (ISDSS'97), Ecole des HEC, University of Lausanne, Switzerland, July 21-22. 1997.
- [14] C.Y. Chiu and A.D. Russell. Design of a construction management data visualization environment: A top-down approach. Automation in Construction, 20(4), 399-417. 2011.
- [15] A. Aguirregoitia, J. J. D. Cosin and C. Presedo. Software project visualization using task oriented metaphors. Journal of Software Engineering and Applications, 3(11), 1015-1026. 2010.
- [16] S. Luz, M. Masoodian, D. McKenzie and W.V. Broeck. Chronos: A tool for interactive scheduling and visualisation of task hierarchies. In 13th International Conference on Information Visualisation, IV09 (July 2009), IEEE Press, pp. 241-246. 2009.
- [17] A. D. Songer, B. Hays and C. North, "Multidimensional visualization of project control data". Construction Innovation: Information, Process, Management, Vol. 4 Iss: 3, pp.173 - 190, 2004.
- [18] yEd. <http://yworks.com>.
- [19] G. Di Battista, E. Pietrosanti, R. Tamassia and I. G. Tollis, "Automatic layout of PERT diagrams with X-PERT". In Visual Languages, 1989., IEEE Workshop on (pp. 171-176). IEEE. 1989.
- [20] M. Chimani, C. Gutwenger, P. Mutzel, P., and H.M. Wong. Upward planarization layout. In Graph Drawing (pp. 94-106). Springer Berlin Heidelberg. 2010.
- [21] yEd Graph Editor Manual. Available under http://yed.yworks.com/support/manual/layout_hierarchic_incremental.html. Accessed on November 27, 2013.
- [22] R. Kolisch and A. Sprecher. "PSPLIB - A project scheduling library", European Journal of Operational Research, Vol. 96, pp. 205-216. 1996.
- [23] R. Kolisch, C. Schwindt and A.Sprecher. "Benchmark instances for project scheduling problems". Kluwer; Weglarz, J. (Hrsg.): Handbook on recent advances in project scheduling, p.197-212. 1999.
- [24] <http://ertekprojects.com/ftp/supp/12.zip>