



HAL
open science

Operation modes and self-motions of the 2-RUU parallel manipulator

Latifah Nurahmi, Stéphane Caro, Philippe Wenger

► **To cite this version:**

Latifah Nurahmi, Stéphane Caro, Philippe Wenger. Operation modes and self-motions of the 2-RUU parallel manipulator. *International Journal of Mechanisms and Robotic Systems*, 2016, 3 (4), pp.280-296. <10.1504/IJMRS.2016.085228>. <hal-01721232>

HAL Id: hal-01721232

<https://hal.science/hal-01721232v1>

Submitted on 1 Mar 2018

HAL is a multi-disciplinary open access archive for the deposit and dissemination of scientific research documents, whether they are published or not. The documents may come from teaching and research institutions in France or abroad, or from public or private research centers.

L'archive ouverte pluridisciplinaire **HAL**, est destinée au dépôt et à la diffusion de documents scientifiques de niveau recherche, publiés ou non, émanant des établissements d'enseignement et de recherche français ou étrangers, des laboratoires publics ou privés.



HAL Authorization

Operation modes and self-motions of the 2-RUU parallel manipulator

Latifah Nurahmi

Stéphane Caro*

Philippe Wenger

Institut de Recherche en Communications et Cybernétique de Nantes

1 rue de la Noë, 44321 Nantes, France

{latifah.nurahmi, stephane.caro, philippe.wenger@ircsyn.ec-nantes.fr}

Abstract

This paper deals with the characterization of the operation modes of the 2-RUU parallel manipulator with an algebraic approach, namely the Study kinematic mapping of the Euclidean group $SE(3)$. The manipulator is described by a set of eight constraint equations and the primary decomposition reveals that the mechanism has three 4-*dof* operation modes. The singularity conditions are obtained by deriving the determinant of the Jacobian matrix of the constraint equations with respect to the Study parameters. It is shown that there exist singular configurations in which the 2-RUU parallel manipulator may switch from one operation mode to another operation mode, which is known as constraint singularity. All the singular configurations are mapped onto the joint space and are physically interpreted. Eventually, the 2-RUU parallel manipulator may switch from the 1st Schönflies mode to the 2nd Schönflies mode, or vice versa, through the additional 4-*dof* mode that contains self-motion.

1 Introduction

Schönflies Motion Generators (SMGs) are very suitable for wide range of applications that require fewer than 6-*dof*. The Schönflies motion contains three independent translations and one pure rotation about an axis of fixed direction, namely 3T1R. This set of motion was first studied by German mathematician-mineralogist Arthur Moritz Schönflies (1853-1928). For this

*Corresponding author. Email: stephane.caro@ircsyn.ec-nantes.fr; Tel: +33 (0)2 40 37 69 68

reason, the set of such motions is known to geometers as the Schönflies subgroup of the group of rigid-body displacements [1]. A list of serial SMGs based on the Lie group-algebraic properties of the displacement set was produced by Lee and Hervé in [2, 3]. While the type synthesis based on the screw theory of the 3T1R parallel manipulators with four identical limb structures was performed in [5]. The singularity analysis of parallel manipulators with identical limb structures performing 3T1R motions based on the Grassmann-Cayley algebra is presented in [6, 7, 8].

In [9], Li and Hervé synthesized parallel manipulators whose moving platform can undergo a bifurcation Schönflies modes. The synthesis is based upon the displacement group to generate the kinematic chains. The authors continued in [10] to present a systematic approach to synthesize the iso-constrained SMGs with two identical 5-*dof* legs. One of the SMGs composed of two identical legs is the 2-RUU parallel manipulator. This manipulator is composed of two RUU legs in which two joints are actuated in each leg.

The method of algebraic geometry, namely the Study kinematic mapping [11], has been widely for the global kinematic analysis of either spatial parallel manipulators or planar parallel manipulators in [12, 13, 14, 15]. Therefore, by using the Study kinematic mapping and the algebraic description of the manipulator architecture, a characterization of the operation modes of the 2-RUU parallel manipulator are discussed in more details in this paper. Due to the unique topology of the RUU limb that comprises two links with one revolute actuator attached to the base, the actuated joint angle always appears in every constraint equation. The constraint equations of each leg are initially derived and the primary decomposition is computed. It turns out that the 2-RUU parallel manipulator has three 4-*dof* operation modes. The singularities are investigated by deriving the determinant of the Jacobian matrix of the constraint equations with respect to the Study parameters. It reveals that the corresponding manipulator is able to change from one operation mode to another operation mode by passing through the configurations that belong to both modes, namely constraint singularity. The singularity conditions are mapped onto the joint space. Finally, the changes of operation modes for the 2-RUU parallel manipulator are illustrated.

This paper is organized as follows: A detailed description of the manipulator architecture is given in Section 2. The constraint equations of the manipulators are expressed in Section 3. These constraint equations are used to identify the operation modes in Section 4. In Section 5, the singularity conditions and self-motion are reviewed. Eventually, the operation modes changing of the 2-RUU parallel manipulator is presented in Section 6.

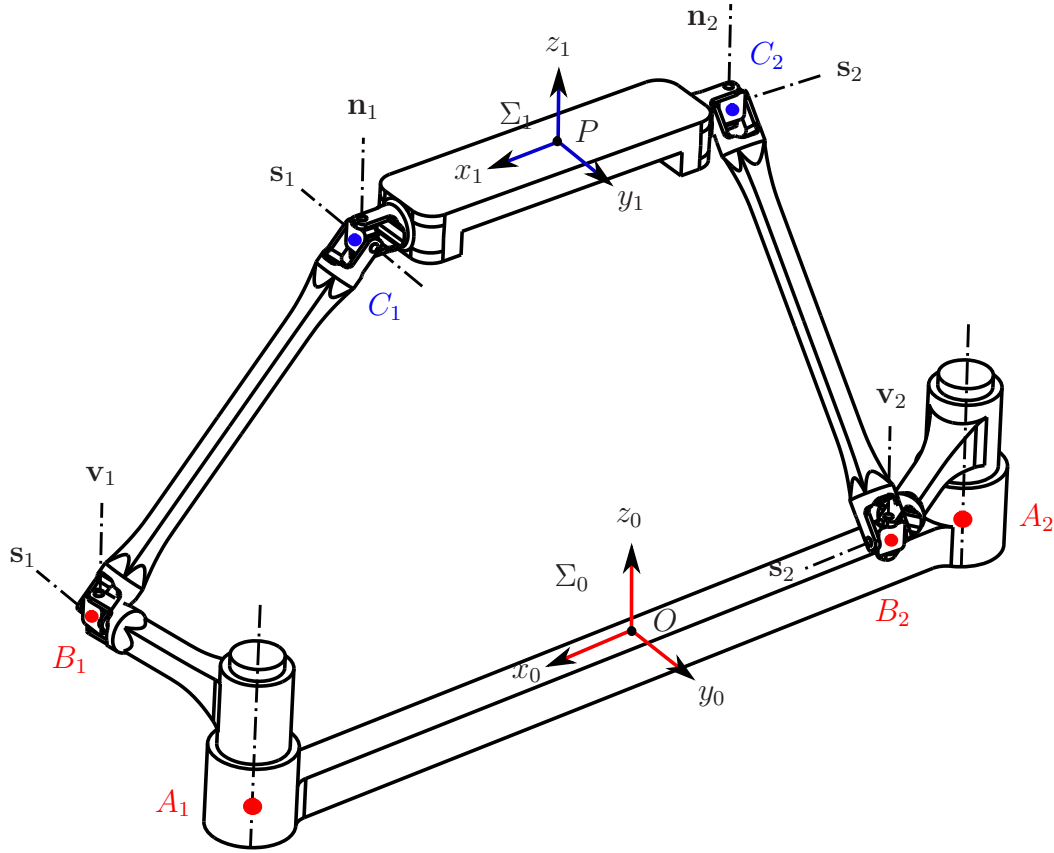

Figure 1: The 2-RUU parallel manipulator.

2 Manipulator architecture

The 2-RUU parallel manipulator shown in Fig. 1, consists of a base, a moving platform, and two identical legs. Each leg is composed of five revolute joints such that the second and the third ones, as well as the fourth and the fifth ones, are built with intersecting and perpendicular axes. Thereby they are assimilated to U-joint. The origin O of the fixed frame Σ_0 and the origin P of the moving frame Σ_1 are located at the center of the base and the moving platform.

The first revolute joint is attached to the base and is actuated. Its rotation angle is defined by θ_{1i} ($i = 1, 2$). The axes of the first and the second joints are directed along z_0 -axis. The axis of the fifth joint is directed along z_1 -axis. The second axis and the fifth axis are denoted by \mathbf{v}_i and \mathbf{n}_i ($i = 1, 2$), respectively. The second revolute joint is also actuated and its rotation angle is defined by θ_{2i} ($i = 1, 2$). The axes of the third and the fourth joints are parallel. The axis of the third joint is denoted by \mathbf{s}_{2i} ($i = 1, 2$) and it changes instantaneously as a function of θ_{2i} as shown in Fig. 2, such that:

$$\mathbf{s}_i = (0, \cos(\theta_{2i}), \sin(\theta_{2i}), 0)^T, \quad i = 1, 2 \quad (1)$$

The first revolute joint of the i -th limb is located at point A_i with distance a from the origin of Σ_0 . The first U-joint is denoted by point B_i with distance l from point A_i . Link A_iB_i always moves in a plane normal to \mathbf{v}_i . Hence the coordinates of points A_i and B_i expressed in the fixed frame Σ_0 are:

$$\begin{aligned} \mathbf{r}_{A_1}^0 &= (1 \ a \ 0 \ 0)^T, & \mathbf{r}_{B_1}^0 &= (1 \ l \cos(\theta_{11}) + a \ l \sin(\theta_{11}) \ 0)^T, \\ \mathbf{r}_{A_2}^0 &= (1 \ -a \ 0 \ 0)^T, & \mathbf{r}_{B_2}^0 &= (1 \ l \cos(\theta_{12}) - a \ l \sin(\theta_{12}) \ 0)^T. \end{aligned} \quad (2)$$

The moving frame Σ_1 is located at the center of the moving platform. The moving platform is connected to the limbs by two U-joints, of which the intersection point of the revolute joint axes is denoted by C_i . The length of the moving platform from the origin of Σ_1 to point C_i is defined by b . The length of link B_iC_i is defined by r . The coordinates of point C_i expressed in the moving frame Σ_1 are:

$$\begin{aligned} \mathbf{r}_{C_1}^1 &= (1 \ b \ 0 \ 0)^T, \\ \mathbf{r}_{C_2}^1 &= (1 \ -b \ 0 \ 0)^T. \end{aligned} \quad (3)$$

As a consequence, there are four design parameters a, b, l, r ; and four joint variables $\theta_{11}, \theta_{12}, \theta_{21}, \theta_{22}$ that determine the motions of the 2-RUU parallel manipulator.

3 Constraint equations

In this section, the constraint equations are derived whose solutions illustrate the possible poses of the moving platform (coordinate frame Σ_1) with respect to Σ_0 . To obtain the coordinates of points C_i and vectors \mathbf{n}_i expressed in Σ_0 , the Study parametrization of a spatial Euclidean transformation matrix $\mathbf{M} \in SE(3)$ based on [11] is used.

$$\mathbf{M} = \begin{pmatrix} x_0^2 + x_1^2 + x_2^2 + x_3^2 & \mathbf{0}_{3 \times 1}^T \\ \mathbf{M}_T & \mathbf{M}_R \end{pmatrix} \quad (4)$$

where \mathbf{M}_T and \mathbf{M}_R represent the translational and rotational parts of the transformation matrix \mathbf{M} , respectively, and are expressed as follows:

$$\begin{aligned} \mathbf{M}_T &= \begin{pmatrix} 2(-x_0y_1 + x_1y_0 - x_2y_3 + x_3y_2) \\ 2(-x_0y_2 + x_1y_3 + x_2y_0 - x_3y_1) \\ 2(-x_0y_3 - x_1y_2 + x_2y_1 + x_3y_0) \end{pmatrix} \\ \mathbf{M}_R &= \begin{pmatrix} x_0^2 + x_1^2 - x_2^2 - x_3^2 & 2(x_1x_2 - x_0x_3) & 2(x_1x_3 + x_0x_2) \\ 2(x_1x_2 + x_0x_3) & x_0^2 - x_1^2 + x_2^2 - x_3^2 & 2(x_2x_3 - x_0x_1) \\ 2(x_1x_3 - x_0x_2) & 2(x_2x_3 + x_0x_1) & x_0^2 - x_1^2 - x_2^2 + x_3^2 \end{pmatrix} \end{aligned} \quad (5)$$

The parameters $x_0, x_1, x_2, x_3, y_0, y_1, y_2, y_3$, which appear in matrix \mathbf{M} , are called *Study pa-*

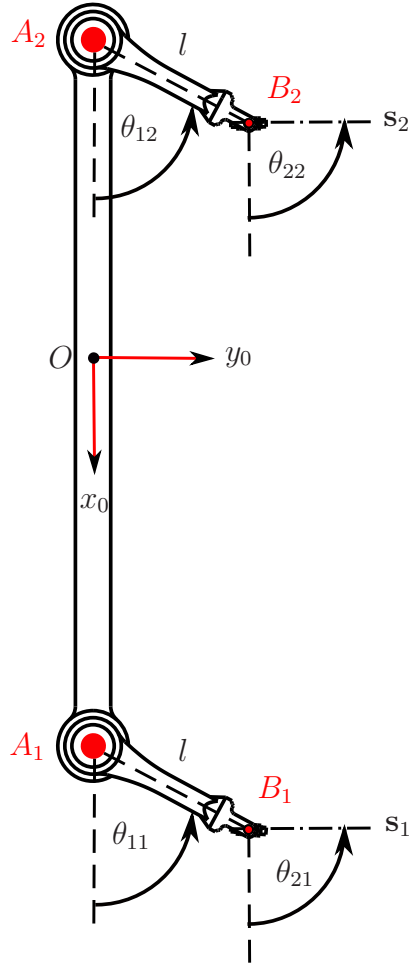

Figure 2: Parametrization of the first two joint angles in each leg from top view.

rameters. These parameters make it possible to parametrize $SE(3)$ with dual quaternions. The *Study kinematic mapping* maps each spatial Euclidean displacement of $SE(3)$ via transformation matrix \mathbf{M} onto a projective point $X [x_0 : x_1 : x_2 : x_3 : y_0 : y_1 : y_2 : y_3]$ in the 6-dimensional Study quadric $S \in \mathbb{P}^7$, such that:

$$SE(3) \rightarrow X \in \mathbb{P}^7$$

$$(x_0 : x_1 : x_2 : x_3 : y_0 : y_1 : y_2 : y_3)^T \neq (0 : 0 : 0 : 0 : 0 : 0 : 0 : 0)^T \quad (6)$$

Every projective point X will represent a spatial Euclidean displacement, if it fulfils the following equation and inequality:

$$x_0y_0 + x_1y_1 + x_2y_2 + x_3y_3 = 0,$$

$$x_0^2 + x_1^2 + x_2^2 + x_3^2 \neq 0 \quad (7)$$

Let us initially perform the tangent half-angle substitutions to rewrite the trigonometric

functions of θ_{ij} ($i, j = 1, 2$) in terms of rational functions of a new variable t_{ij} . However, the tangent half-angle substitutions will increase the degree of variables and make the computation quite heavy.

$$\cos(\theta_{ij}) = \frac{1 - t_{ij}^2}{1 + t_{ij}^2}, \quad \sin(\theta_{ij}) = \frac{2t_{ij}}{1 + t_{ij}^2}, \quad i, j = 1, 2 \quad (8)$$

where $t_{ij} = \tan(\frac{\theta_{ij}}{2})$. The coordinates of points C_i and vectors \mathbf{n}_i expressed in the fixed frame Σ_0 are obtained by:

$$\mathbf{r}_{C_i}^0 = \mathbf{M} \cdot \mathbf{r}_{C_i}^1, \quad \mathbf{n}_i^0 = \mathbf{M} \cdot \mathbf{n}_i^1, \quad i = 1, 2 \quad (9)$$

As the coordinates of all points are given in terms of the Study parameters and the design parameters, the constraint equations can be derived by examining the design of RUU limb. The link connecting points B_i and C_i is coplanar to the vectors \mathbf{v}_i and \mathbf{n}_i^0 . Accordingly, the scalar triple product of vectors $(\mathbf{r}_{C_i}^0 - \mathbf{r}_{B_i}^0)$, \mathbf{v}_i and \mathbf{n}_i^0 vanishes, namely:

$$(\mathbf{r}_{C_i}^0 - \mathbf{r}_{B_i}^0)^T \cdot (\mathbf{v}_i \times \mathbf{n}_i^0) = 0, \quad i = 1, 2 \quad (10)$$

After computing the corresponding scalar triple product and removing the common denominators, the following constraint equations come out as stated in [14]:

$$g_1 : (at_{11}^2 - bt_{11}^2 - lt_{11}^2 + a - b + l)x_0x_1 + 2lt_{11}x_0x_2 - (2t_{11}^2 + 2)x_0y_0 + 2lt_{11}x_3x_1 + (-at_{11}^2 - bt_{11}^2 + lt_{11}^2 - a - b - l)x_3x_2 + (-2t_{11}^2 - 2)y_3x_3 = 0 \quad (11a)$$

$$g_2 : (at_{12}^2 - bt_{12}^2 + lt_{12}^2 + a - b - l)x_0x_1 - 2lt_{12}x_0x_2 + (2t_{12}^2 + 2)x_0y_0 - 2lt_{12}x_1x_3 + (-at_{12}^2 - bt_{12}^2 - lt_{12}^2 - a - b + l)x_2x_3 + (2t_{12}^2 + 2)x_3y_3 = 0 \quad (11b)$$

To derive the constraint equations corresponding to the link length r of link B_iC_i , the distance equation can be formulated as: $\|(\mathbf{r}_{C_i}^0 - \mathbf{r}_{B_i}^0)\|^2 = r^2$. As a consequence, the following two equations are obtained:

$$g_3 : (a^2t_{11}^2 - 2abt_{11}^2 - 2alt_{11}^2 + b^2t_{11}^2 + 2blt_{11}^2 + l^2t_{11}^2 - r^2t_{11}^2 + a^2 - 2ab + 2al + b^2 - 2bl + l^2 - r^2)x_0^2 - 8blt_{11}x_0x_3 + (4at_{11}^2 - 4bt_{11}^2 - 4lt_{11}^2 + 4a - 4b + 4l)\dots = 0 \quad (12a)$$

$$g_4 : (a^2t_{12}^2 - 2abt_{12}^2 + 2alt_{12}^2 + b^2t_{12}^2 - 2blt_{12}^2 + l^2t_{12}^2 - r^2t_{12}^2 + a^2 - 2ab - 2al + b^2 + 2bl + l^2 - r^2)x_0^2 + 8blt_{12}x_0x_3 + (-4at_{12}^2 + 4bt_{12}^2 - 4lt_{12}^2 - 4a + 4b + 4l)\dots = 0 \quad (12b)$$

To derive the constraint equations corresponding to the actuation of the second joint of each

limb, the scalar product of vector $(\mathbf{r}_{C_i}^0 - \mathbf{r}_{B_i}^0)$ and vector \mathbf{s}_i is expressed as: $(\mathbf{r}_{C_i}^0 - \mathbf{r}_{B_i}^0)^T \mathbf{s}_i = 0$. Hence, the following constraint equations are obtained:

$$g_5 : (-at_{11}^2 t_{21}^2 + bt_{11}^2 t_{21}^2 + lt_{11}^2 t_{21}^2 + at_{11}^2 - at_{21}^2 - bt_{11}^2 + bt_{21}^2 - lt_{11}^2 + 4lt_{11}t_{21} - lt_{21}^2 + a - b + l)x_0^2 - 4bt_{21}(t_{11}^2 + 1)x_0x_3 - 2(t_{21}^2 - 1)(t_{11}^2 + 1)x_0y_1 + 4t_{21}(t_{11}^2 + 1)\dots = 0 \quad (13a)$$

$$g_6 : (at_{12}^2 t_{22}^2 - bt_{12}^2 t_{22}^2 + lt_{12}^2 t_{22}^2 - at_{12}^2 + at_{22}^2 + bt_{12}^2 - bt_{22}^2 - lt_{12}^2 + 4lt_{12}t_{22} - lt_{22}^2 - a + b + l)x_0^2 + 4bt_{22}(t_{12}^2 + 1)x_0x_3 - 2(t_{22}^2 - 1)(t_{12}^2 + 1)x_0y_1 + 4t_{22}(t_{12}^2 + 1)\dots = 0 \quad (13b)$$

All solutions have to be within the Study quadric, thus the Study-equation and the normalization equation are added as the constraint equations, as follows:

$$g_7 : x_0y_0 + x_1y_1 + x_2y_2 + x_3y_3 = 0 \quad (14a)$$

$$g_8 : x_0^2 + x_1^2 + x_2^2 + x_3^2 - 1 = 0 \quad (14b)$$

4 Operation mode

Firstly, the design parameters are assigned as $a = 2, b = 1, l = 1, r = 2$. The set of eight constraint equations is written as a polynomial ideal with variables $\{x_0, x_1, x_2, x_3, y_0, y_1, y_2, y_3\}$ over the coefficient ring $\mathbb{C}[t_{11}, t_{12}, t_{21}, t_{22}]$, defined as:

$$\mathcal{I} = \langle g_1, g_2, g_3, g_4, g_5, g_6, g_7, g_8 \rangle \quad (15)$$

At this point, the following ideal is examined: $\mathcal{J} = \langle g_1, g_2, g_7 \rangle$. The primary decomposition is computed to verify if the ideal \mathcal{J} is the intersection of several smaller ideals. Indeed, the ideal \mathcal{J} is decomposed into three components as follows:

$$\mathcal{J} = \bigcap_{n=1}^3 \mathcal{J}_n \quad (16)$$

with the results of primary decomposition:

$$\begin{aligned} \mathcal{J}_1 &= \langle x_0, x_3, x_1y_1 + x_2y_2 \rangle \\ \mathcal{J}_2 &= \langle x_1, x_2, x_0y_0 + x_3y_3 \rangle \\ \mathcal{J}_3 &= \langle (t_{11}^2 t_{13} + 2t_{11}t_{13}^2 + t_{11} + 2t_{13})x_3y_0 + (t_{11}^2 t_{13}^2 - 1)x_1y_1 + \dots \rangle \end{aligned} \quad (17)$$

Accordingly, the 2-RUU parallel manipulator under study has three operation modes. The computation of the Hilbert dimension of ideal \mathcal{J}_n with $t_{11}, t_{12}, t_{21}, t_{22}$ treated as variables shows

that:

$$\dim(\mathcal{J}_n) = 4 \quad n = 1, \dots, 3 \quad (18)$$

where \dim denotes the dimension over $\mathbb{C}[a, b, l, r]$. To complete the analysis, the remaining equations are added by writing:

$$\mathcal{K}_n : \mathcal{J}_n \cup \langle g_3, g_4, g_5, g_6, g_8 \rangle, \quad n = 1, \dots, 3 \quad (19)$$

It follows that the 2-RUU parallel manipulator has three 4-*dof* operation modes. This type of manipulator is called *variable-dof* parallel manipulator in [16]. Each system $\mathcal{K}_{i(I)}$ associated with a specific operation mode that will be discussed in the following.

4.1 System \mathcal{K}_1 : 1st Schönflies mode

In this operation mode, the moving platform is reversed about an axis parallel to the x_0y_0 -plane of Σ_0 by 180 degrees from the identity condition. The identity condition is when the moving frame and the fixed frame are coincident, i.e. $\Sigma_1 \equiv \Sigma_0$ and the transformation matrix becomes an identity matrix. The condition $x_0 = 0, x_3 = 0, x_1y_1 + x_2y_2 = 0$ are valid for all poses and are substituted into the transformation matrix \mathbf{M} defined in Eq. (4), such that:

$$\mathbf{M}_1 = \begin{pmatrix} 1 & 0 & 0 & 0 \\ 2(x_1y_0 - x_2y_3) & x_1^2 - x_2^2 & 2x_1x_2 & 0 \\ 2(x_1y_3 + x_2y_0) & 2x_1x_2 & -x_1^2 + x_2^2 & 0 \\ -\frac{2y_2}{x_1} & 0 & 0 & -1 \end{pmatrix} \quad (20)$$

From the transformation matrix \mathbf{M}_1 , it can be seen that the 2-RUU parallel manipulator has 3-*dof* translational motions, which are parametrized by y_0, y_2, y_3 and 1-*dof* rotational motion, which is parametrized by x_1, x_2 in connection with $x_1^2 + x_2^2 - 1 = 0$ [17]. The z_1 -axis of frame Σ_1 attached to the moving platform is always pointing downward in this operation mode and the moving platform remains parallel to the base.

4.2 System \mathcal{K}_2 : 2nd Schönflies mode

In this operation mode, the condition $x_1 = 0, x_2 = 0, x_0y_0 + x_3y_3 = 0$ are valid for all poses. The transformation matrix in this operation mode is written as:

$$\mathbf{M}_2 = \begin{pmatrix} 1 & 0 & 0 & 0 \\ -2(x_0y_1 - x_3y_2) & x_0^2 - x_3^2 & -2x_0x_3 & 0 \\ -2(x_0y_2 + x_3y_1) & 2x_0x_3 & x_0^2 - x_3^2 & 0 \\ -\frac{2y_3}{x_0} & 0 & 0 & 1 \end{pmatrix} \quad (21)$$

From the transformation matrix \mathbf{M}_2 , it can be seen that the 2-RUU parallel manipulator has 3-*dof* translational motions, which are parametrized by y_1, y_2, y_3 and 1-*dof* rotational motion, which is parametrized by x_0, x_3 in connection with $x_0^2 + x_3^2 - 1 = 0$ [17]. In this operation mode, the z_1 -axis of frame Σ_1 attached the moving platform is always pointing upward and the moving platform remains parallel to the base.

The systems \mathcal{K}_1 and \mathcal{K}_2 perform the same motion type, i.e. 3T1R, however they do not have configurations in common since the orientation of the moving platform is not the same from one operation mode to the other. The z_1 -axis of frame Σ_1 attached to the moving platform in system \mathcal{K}_1 is always pointing downward (the moving platform is always tilted by 180 degrees), while in the system \mathcal{K}_2 , the z_1 -axis of frame Σ_1 attached to the moving platform is always pointing upward.

4.3 System \mathcal{K}_3 : Third mode

In this operation mode, the moving platform is no longer parallel to the base. The variables x_3, y_0, y_1 can be solved linearly from the ideal \mathcal{J}_3 and are shown in Eq. (22). Since solving the inverse kinematics of t_{11}, t_{12} are quite computationally expensive, the joint variables t_{12}, t_{12} are considered to be the independent parameters of this mode. Then the parameters y_2, y_3 can be solved in terms of $(x_0, x_1, x_2, t_{11}, t_{12})$. Substituting back the parameters y_2, y_3 into Eq. (22), then the Study parameters x_3, y_0, y_1, y_2, y_3 are now parametrized by $(x_0, x_1, x_2, t_{11}, t_{12})$. Accordingly, the 2-RUU parallel manipulator will perform two translational motions, which are parametrized by variables t_{11}, t_{12} and two rotational motions, which are parametrized by variables x_0, x_1, x_2 in connection with the normalization equation g_8 , which is known as 2T2R motion.

$$\begin{aligned}
x_3 &= \frac{(t_{11}^2 t_{13}^2 x_1 - t_{11}^2 t_{13} x_2 + t_{11} t_{13}^2 x_2 + 2t_{13}^2 x_1 + t_{11} x_2 - t_{13} x_2 + x_1)x_0}{(3t_{11}^2 t_{13}^2 x_2 + t_{11}^2 t_{13} x_1 - t_{11} t_{13}^2 x_1 + 2t_{11}^2 x_2 + 4t_{13}^2 x_2 - t_{11} x_1 + t_{13} x_1 + 3x_2)} \\
y_0 &= -\frac{t_{11}^2 t_{13}^2 x_1 x_2 + t_{11}^2 t_{13} x_1 - t_{11} t_{13}^2 x_1 + 2t_{11}^2 x_2 + 4t_{13}^2 x_2 - t_{11} x_1 + t_{13} x_1 + 3x_2}{3t_{11}^2 t_{13}^2 x_2 + t_{11}^2 t_{13} x_1 - t_{11} t_{13}^2 x_1 + 2t_{11}^2 x_2 + 4t_{13}^2 x_2 - t_{11} x_1 + t_{13} x_1 + 3x_2} (t_{11}^2 t_{13}^2 x_1 x_2 + \\
&\quad t_{11}^2 t_{13}^2 x_1 y_3 - t_{11}^2 t_{13} x_2^2 - t_{11}^2 t_{13} x_2 y_3 - t_{11} t_{13}^2 x_1^2 - 2t_{11} t_{13}^2 x_2^2 + t_{11} t_{13}^2 x_2 y_3 + 2t_{13}^2 x_1 y_3 - t_{11} \\
&\quad x_2^2 + t_{11} x_2 y_3 - t_{13} x_1^2 - 2t_{13} x_2^2 - t_{13} x_2 y_3 - x_1 x_2 + x_1 y_3) \\
y_1 &= \frac{1}{(3t_{11}^2 t_{13}^2 x_2 + t_{11}^2 t_{13} x_1 - t_{11} t_{13}^2 x_1 + 2t_{11}^2 x_2 + 4t_{13}^2 x_2 - t_{11} x_1 + t_{13} x_1 + 3x_2)x_1} (t_{11}^2 t_{13}^2 x_0 \\
&\quad x_1 x_2 - 3t_{11}^2 t_{13}^2 x_2^2 y_2 - t_{11}^2 t_{13} x_0 x_2^2 - t_{11}^2 t_{13} x_1 x_2 y_2 - t_{11} t_{13}^2 x_0 x_1^2 - 2t_{11} t_{13}^2 x_0 x_2^2 + t_{11} t_{13}^2 x_1 \\
&\quad x_2 y_2 - 2t_{11}^2 x_2^2 y_2 - 4t_{13}^2 x_2^2 y_2 - t_{11} x_0 x_2^2 + t_{11} x_1 x_2 y_2 - t_{13} x_0 x_1^2 - 2t_{13} x_0 x_2^2 - t_{13} x_1 x_2 y_2 \\
&\quad - x_0 x_1 x_2 - 3x_2^2 y_2)
\end{aligned} \tag{22}$$

Under this operation mode, the joint angles t_{21} and t_{22} can be computed from the equations g_5, g_6 . It turns out that no matter the value of the first actuated joints (t_{11}, t_{12}) in each leg, these equations vanish for two real solutions, namely:

1. $t_{21} = -\frac{1}{t_{22}} : (\theta_{21} = \pi + \theta_{22})$
2. $t_{21} = t_{22} : (\theta_{21} = \theta_{22})$

As a consequence, in this operation mode, the links $B_i C_i$ ($i = 1, 2$) from both legs are always parallel to the same plane. Likewise, the axes \mathbf{s}_i ($i = 1, 2$) from both limbs are always parallel as well, i.e. $\mathbf{s}_1 \parallel \mathbf{s}_2$, as shown in Fig. 3.

5 Singularity conditions and self-motion

The 2-RUU parallel manipulator reaches a singularity condition when the determinant of its Jacobian matrix vanishes. The Jacobian matrix is the matrix of all first order partial derivatives of the eight constraint equations with respect to the eight Study parameters. Since the 2-RUU parallel manipulator has more than one operation mode, the singular configurations can be classified into two different types, i.e. the configurations that belong to a single operation mode and the singularity configurations that belong to more than one operation mode. The common configurations that belong to more than one operation mode allow the 2-RUU parallel manipulator to switch from one mode to another mode, which will be discussed in Section 6. However, the 1st Schönflies mode and the 2nd Schönflies mode do not have configurations in common, since the variables x_0, x_1, x_2, x_3 can never vanish simultaneously. Furthermore, in

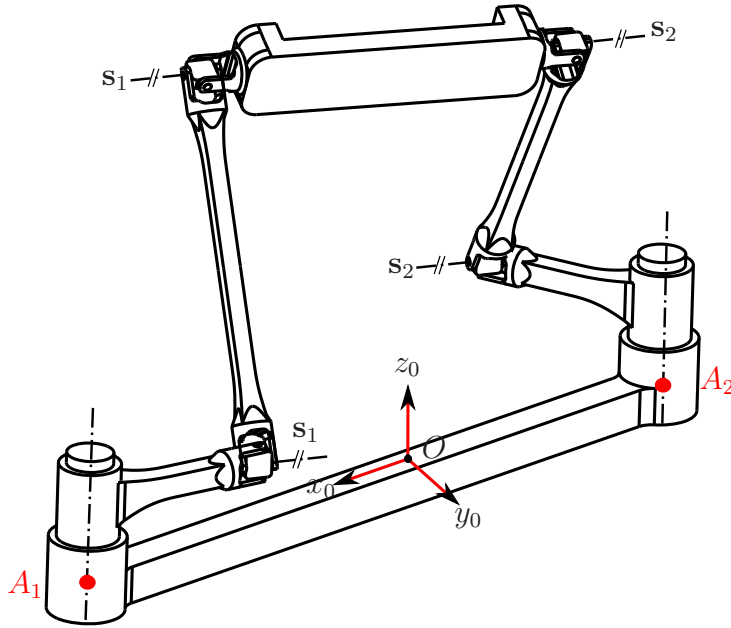
Figure 3: A pose in the third mode \mathcal{K}_3 .

certain condition of the actuated joints, the moving platform can exhibit full cycle motion (one or more *dof*) while the actuated joints are locked, thus it is referred as *self-motion*. Some researchers investigated the self-motion of parallel manipulators in [18, 19].

The singular poses are examined by taking the Jacobian matrix from each system of polynomial \mathcal{K}_n and computing its determinant.

$$S_n : \det(\mathbf{J}_n) = 0, \quad n = 1, \dots, 3 \quad (23)$$

From practical point of view, the singularity surface is desirable also in the joint space. Hence the expression of the Jacobian determinant is added into each system \mathcal{K}_n and all Study parameters are eliminated to obtain a single polynomial in the joint variables $t_{11}, t_{12}, t_{21}, t_{22}$. The detail analysis of the singularity conditions in each operation mode is discussed in the following.

5.1 Singularities in 1st Schönflies mode (\mathcal{K}_1)

For the 1st Schönflies mode, the determinant of Jacobian matrix $S_1 : \det(\mathbf{J}_1) = 0$ has four factors. The first factor is $y_2 = 0$, when the moving platform is coplanar to the base, the mechanism is always in a singular configuration. The second factor shows the singularity configurations that lie in the intersection with \mathcal{K}_2 . However, this factor is neglected since systems \mathcal{K}_1 and \mathcal{K}_2 do not have configurations in common.

The inspection of the third factor yields the singularity configurations that belong to the 1st

Schönflies mode \mathcal{K}_1 and the third mode \mathcal{K}_3 , which will be discussed in Section 6. Eventually, the last factor of the determinant of Jacobian matrix $S_1 : \det(\mathbf{J}_1) = 0$ is analysed. This factor is added to the system \mathcal{K}_1 and all Study parameters are eliminated. The elimination yields a polynomial degree 12 in terms of joint angles, as follows:

$$-3t_{11}^{12}t_{12}^{12}t_{21}^6t_{22}^5 - 3t_{11}^{12}t_{12}^{12}t_{21}^5t_{22}^6 + 3t_{11}^{12}t_{12}^{11}t_{21}^6t_{22}^6 - 3t_{11}^{11}t_{12}^{12}t_{21}^6t_{22}^6 + 10t_{11}^{12}t_{12}^{12}t_{21}^6t_{22}^3 + 45t_{11}^{12}t_{12}^{12}t_{21}^5 \dots = 0 \quad (24)$$

Let us consider one singularity configuration of the 2-RUU parallel manipulator in the 1st Schönflies mode by solving Eq. (24) with $t_{11} = 1, t_{12} = 1/2, t_{21} = -1, t_{22} = -0.0993$. Hence, the direct kinematics of at least one singularity configuration can be obtained with $\theta_{11} = 90^\circ, \theta_{12} = 53.157^\circ, \theta_{21} = -90^\circ, \theta_{22} = -11.347^\circ$, as shown in Fig. 4.

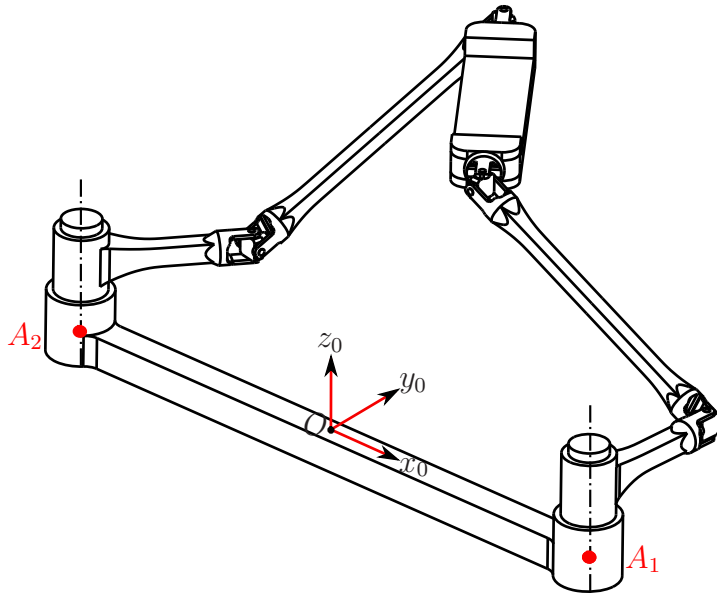

Figure 4: A singularity configuration in the 1st Schönflies mode \mathcal{K}_1 .

5.2 Singularities in 2nd Schönflies mode (\mathcal{K}_2)

For the 2nd Schönflies mode, the determinant of Jacobian matrix $S_2 : \det(\mathbf{J}_2) = 0$ has four factors too. The first factor is $y_3 = 0$ in which the moving platform is coplanar to the base, hence the mechanism is always in a singular configuration. The second factor gives the condition in which the mechanism is in the intersection of systems \mathcal{K}_1 and \mathcal{K}_2 . As explained in Section 5, this factor is removed.

The analysis of the third factor yields the singularity configurations that belong to the 2nd

Schönflies mode \mathcal{K}_2 and the third mode \mathcal{K}_3 , which will be discussed in Section 6. Finally, the last factor of the determinant of Jacobian matrix S_2 : $\det(\mathbf{J}_2) = 0$ is analysed. This factor is added to the system \mathcal{K}_2 and all Study parameters are eliminated. The elimination yields a polynomial degree 12 in terms of joint angles, as follows:

$$-3t_{11}^{12}t_{12}^{12}t_{21}^6t_{22}^5 - 3t_{11}^{12}t_{12}^{12}t_{21}^5t_{22}^6 + 3t_{11}^{12}t_{12}^{11}t_{21}^6t_{22}^6 - 3t_{11}^{11}t_{12}^1t_{21}^6t_{22}^6 + 10t_{11}^{12}t_{12}^{12}t_{21}^6t_{22}^3 + 45t_{11}^{12}t_{12}^{12}t_{21}^5 \dots = 0 \quad (25)$$

Let us consider one singularity configuration of the 2-RUU parallel manipulator in the 2nd Schönflies mode by solving Eq. (25) with $t_{11} = 1, t_{12} = -1/6, t_{21} = -2/3, t_{22} = -2.71$. Hence, the direct kinematics of at least one singularity configuration can be obtained with $\theta_{11} = 90^\circ, \theta_{12} = -18.93^\circ, \theta_{21} = -67.41^\circ, \theta_{22} = -139.56^\circ$, as shown in Fig. 5.

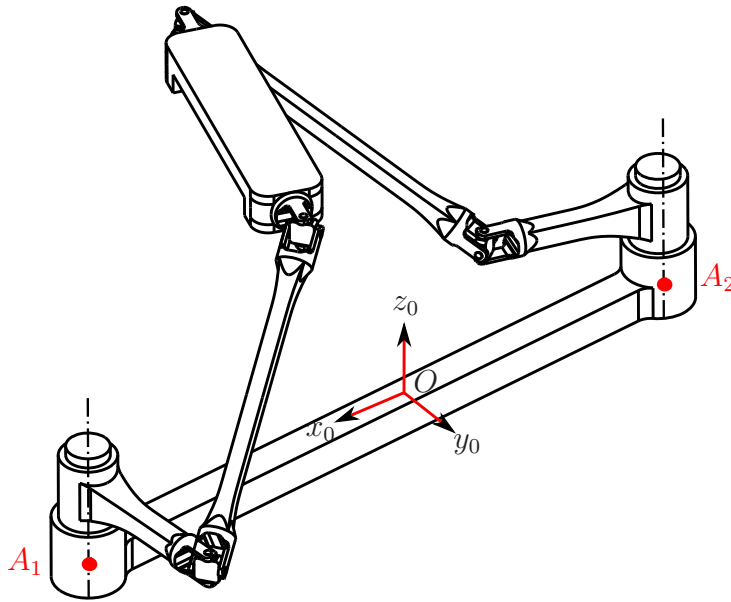

Figure 5: A singularity configuration in the 2nd Schönflies mode \mathcal{K}_2 .

5.3 Self-motion in Third mode (\mathcal{K}_3)

The determinant of the Jacobian matrix is computed in the system \mathcal{K}_3 , which consists of five constraint equations over five variables. Hence the 5×5 Jacobian matrix can be obtained. The determinant of this Jacobian matrix S_3 : $\det(\mathbf{J}_3) = 0$ consists of 10 factors. Surprisingly, two of ten factors are the necessary conditions for the 2-RUU parallel manipulator to be in the system \mathcal{K}_3 , i.e. $\mathbf{s}_1 \parallel \mathbf{s}_2$, as explained in Section 4.3, namely:

1. $t_{21} = -\frac{1}{t_{22}}$: ($\theta_{21} = \pi + \theta_{22}$)

$$2. t_{21} = t_{22} \quad : (\theta_{21} = \theta_{22})$$

It shows that every configuration in the system \mathcal{K}_3 is always singular. When the actuators are locked, the moving platform can exhibit 1-*dof* full cycle motion, which is referred as a self-motion. Therefore, every configuration in the third mode \mathcal{K}_3 amounts to self-motion.

6 Operation mode changing

There exist common configurations where the mechanism, i.e. the 2-RUU parallel manipulator, can switch from one operation mode to another operation mode. These configurations are well known as transition configurations. Transition configuration analysis is an important issue in the design process and control of the parallel manipulators with multiple operation modes [20].

However, the 1st Schönflies mode and the 2nd Schönflies mode do not have configurations in common, since the variables x_0, x_1, x_2, x_3 can never vanish simultaneously. It means that the 2-RUU parallel manipulator cannot switch from the 1st Schönflies mode to the 2nd Schönflies mode, or vice versa, directly. To change from the 1st Schönflies mode to the 2nd Schönflies mode, or vice versa, the 2-RUU parallel manipulator should pass through the third mode, namely system \mathcal{K}_3 . There exist some configurations in which the mechanism can change from the 1st Schönflies mode to the third mode or vice versa, and these configurations belong to both operation modes. Noticeably, these configurations are also singular configurations since they lie in the intersection of two operation modes, which are referred as constraint singularity.

In the following, the conditions on the actuated joint angles for the 2-RUU parallel manipulator to change from one operation mode to another are presented. Each pair of ideals $\{\mathcal{K}_n \cup \mathcal{K}_m\}$ is analysed and the Study parameters are eliminated to find common solutions.

6.1 1st Schönflies Mode (\mathcal{K}_1) \longleftrightarrow Third Mode (\mathcal{K}_3)

To switch from the 1st Schönflies mode (\mathcal{K}_1) to the third mode (\mathcal{K}_3) or vice versa, one should find the configurations of the 2-RUU parallel manipulator that fulfil the condition of both operation modes, namely $(\mathcal{K}_1 \cup \mathcal{K}_3)$. This condition is derived by computing the determinant of Jacobian which is presented in Section 5.1. It turns out that the third factor of the determinant yields the singularity configurations that belong to the 1st Schönflies mode \mathcal{K}_1 and the third mode \mathcal{K}_3 . Then, all Study parameters are eliminated. The elimination yields two polynomials of degree eight and degree nine in $t_{11}, t_{12}, t_{21}, t_{22}$, respectively. The factorization splits both polynomials into four factors as follows:

$$\begin{aligned} f_1 : & (t_{21}t_{22} + 1)(t_{21} - t_{22})(t_{12} + t_{11})(3t_{11}^2t_{12}^2 - 2t_{11}t_{12} + 8t_{12}^2 + 3) \\ f_2 : & (t_{21}t_{22} + 1)(t_{21} - t_{22})(t_{12}^2 + 1)(3t_{11}^2t_{12}^2 - 2t_{11}t_{12} + 8t_{12}^2 + 3) \end{aligned} \quad (26)$$

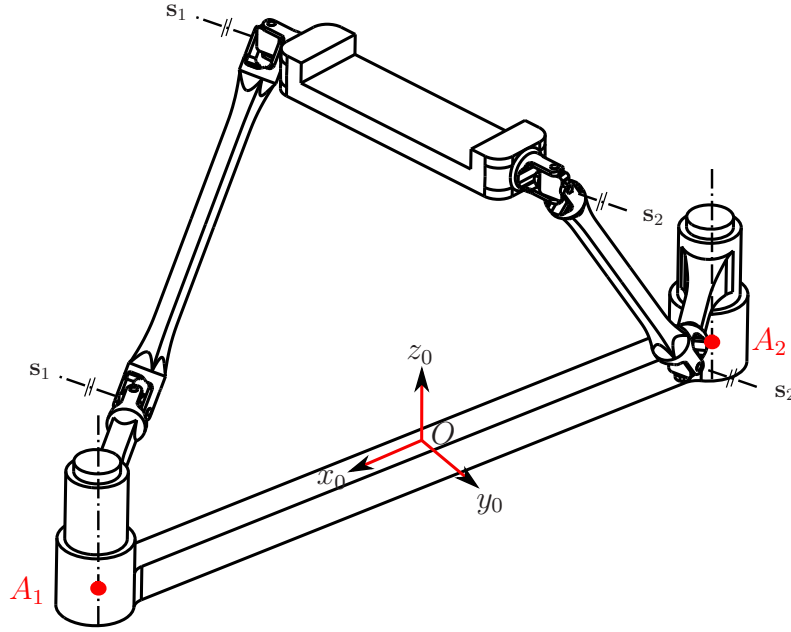
Figure 6: Transition configuration between \mathcal{K}_1 and \mathcal{K}_3 .

The polynomial equations f_1, f_2 vanish simultaneously when they fulfil one of the conditions stated below:

1. $t_{21} = -\frac{1}{t_{22}} : (\theta_{21} = \pi + \theta_{22})$
2. $t_{21} = t_{22} : (\theta_{21} = \theta_{22})$

These conditions mean that when the second link B_iC_i ($i = 1, 2$) from both legs are parallel to the same plan, i.e. $\mathbf{s}_1 \parallel \mathbf{s}_2$, and the moving platform is twisted about an axis parallel to the x_0y_0 -plane of the frame Σ_0 by 180 degrees, the 2-RUU parallel manipulator is in the intersection of the 1st Schönflies mode and the third mode, as shown in Fig. 6. Moreover, these two conditions are contained in the determinant of Jacobian of the third mode $S_3 : \det(\mathbf{J}_3) = 0$, as described in Section 5.1. As a consequence, the transition configurations between \mathcal{K}_1 and \mathcal{K}_3 amount to self-motion.

6.2 2nd Schönflies Mode (\mathcal{K}_2) \longleftrightarrow Third Mode (\mathcal{K}_3)

To switch from the 2nd Schönflies mode (\mathcal{K}_2) to the third mode (\mathcal{K}_3) or vice versa, one should find the configurations of the 2-RUU parallel manipulator that fulfil the condition of both operation modes, namely $(\mathcal{K}_2 \cup \mathcal{K}_3)$. This condition is obtained by computing the determinant of Jacobian which is presented in Section 5.2. It is shown that the third factor of the determinant yields the singularity configurations that belong to the 2nd Schönflies mode \mathcal{K}_2 and the third

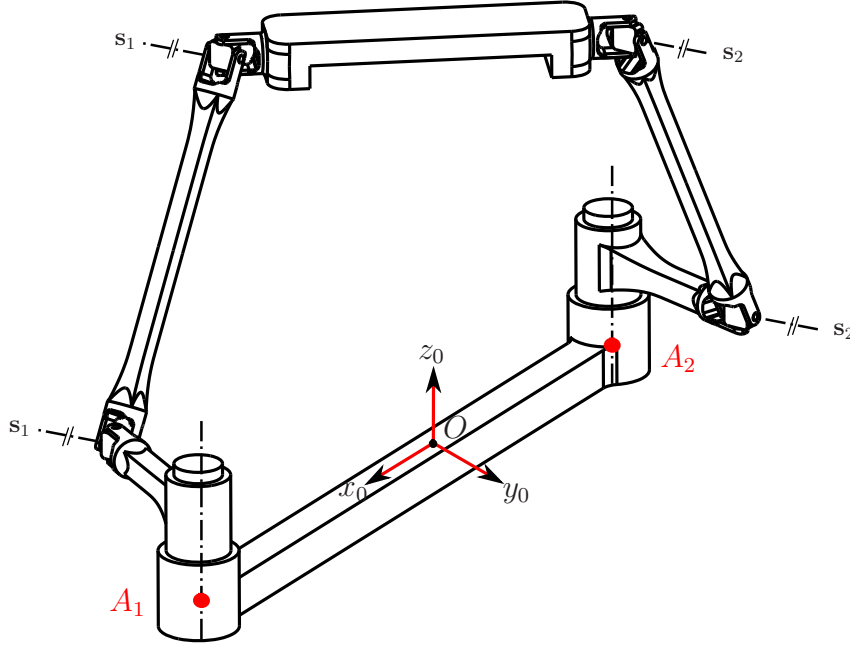
Figure 7: Transition configuration between \mathcal{K}_1 and \mathcal{K}_3 .

mode \mathcal{K}_3 . Then, all Study parameters are eliminated. The elimination yields two polynomials of degree eight and degree nine in $t_{11}, t_{12}, t_{21}, t_{22}$, respectively. The factorization splits both polynomials into four factors as follows:

$$\begin{aligned} f_1 &: (t_{21}t_{22} + 1)(t_{21} - t_{22})(t_{12} + t_{11})(3t_{11}^2t_{12}^2 - 2t_{11}t_{12} + 8t_{12}^2 + 3) \\ f_2 &: (t_{21}t_{22} + 1)(t_{21} - t_{22})(t_{12}^2 + 1)(3t_{11}^2t_{12}^2 - 2t_{11}t_{12} + 8t_{12}^2 + 3) \end{aligned} \quad (27)$$

The polynomial equations f_1, f_2 vanish simultaneously when they fulfil one of the conditions stated below:

1. $t_{21} = -\frac{1}{t_{22}} : (\theta_{21} = \pi + \theta_{22})$
2. $t_{21} = t_{22} : (\theta_{21} = \theta_{22})$

These two conditions mean that when the second link B_iC_i ($i = 1, 2$) from both limbs are parallel to the same plane, i.e. $\mathbf{s}_1 \parallel \mathbf{s}_2$, and the moving platform is parallel to the base, the 2-RRR parallel manipulator is in the intersection of the 2nd Schönflies mode and the third mode, as shown in Fig. 7. Furthermore, these two conditions are contained in the determinant of Jacobian of the third mode $S_3 : \det(\mathbf{J}_3) = 0$, as described in Section 5.2. It reveals that the transition configurations between \mathcal{K}_1 and \mathcal{K}_3 amount to self-motion. The transition between the 1st Schönflies mode \mathcal{K}_1 and the 2nd Schönflies mode \mathcal{K}_2 are possible and it occurs if and

only if the moving platform passes through the third mode \mathcal{K}_3 that contains self-motion, as depicted in Fig. 8(a)-8(f).

7 Conclusions

In this paper, the method of algebraic geometry was applied to characterize the type of operation modes of the 2-RUU parallel manipulator. The set of eight constraint equations are firstly derived and the primary decomposition is computed. It reveals that the 2-RUU parallel manipulator has three 4-*dof* operation modes, namely the 1st Schönflies mode, the 2nd Schönflies mode, and the additional 2T2R mode. The physical interpretation of each operation mode was provided. The singularity conditions were computed and represented in the joint space, i.e. the actuated joint angles $(\theta_{11}, \theta_{12}, \theta_{21}, \theta_{22})$. It turns out that every configuration in the third mode amounts to self-motion. Eventually, the 2-RUU parallel manipulator is able to switch from the 1st Schönflies mode to the 2nd Schönflies mode, or vice versa, by passing through the third mode that contains self-motions.

References

- [1] Angeles, J., Caro, S., Waseem, K., and Morozov, A. (2006). “The Design and Prototyping of an Innovative Schönflies Motion Generator.”, In Institution of Mechanical Engineers. Part C, Journal of Mechanical Engineering Science, **220**(C7), pp. 934–944.
- [2] Chung-Chiing Lee and Jacques M. Herve. (2005). “On the Enumeration of Schönflies Motion Generators.”, In the 9th IFToMM International Symposium on Theory Of Machine and Mechanisms, Bucharest, Romania.
- [3] Chung-Chiing Lee and Jacques M. Herve. (2005). “Translational Parallel Manipulators with Doubly Planar Limbs.”, Mechanism and Machine Theory, **41**(4), pp. 433–455.
- [4] Kong, X. and Gosselin, C.M. (2007). “Type Synthesis of Parallel Mechanisms.”, Springer, Heidelberg, **33**, pp. 141–157.
- [5] Kong, X. and Gosselin, C.M. (2007). “Type Synthesis of Parallel Mechanisms.”, Springer, Heidelberg, **33**, pp. 141–157.
- [6] Amine, S., Masouleh, M., Caro, S., Wenger, P., and Gosselin, C. (2011). “Singularity Analysis of the 4-RUU Parallel Manipulator Using Grassmann-Cayley Algebra.”, Transactions of the Canadian Society for Mechanical Engineering, **35**(5), pp. 515–528.

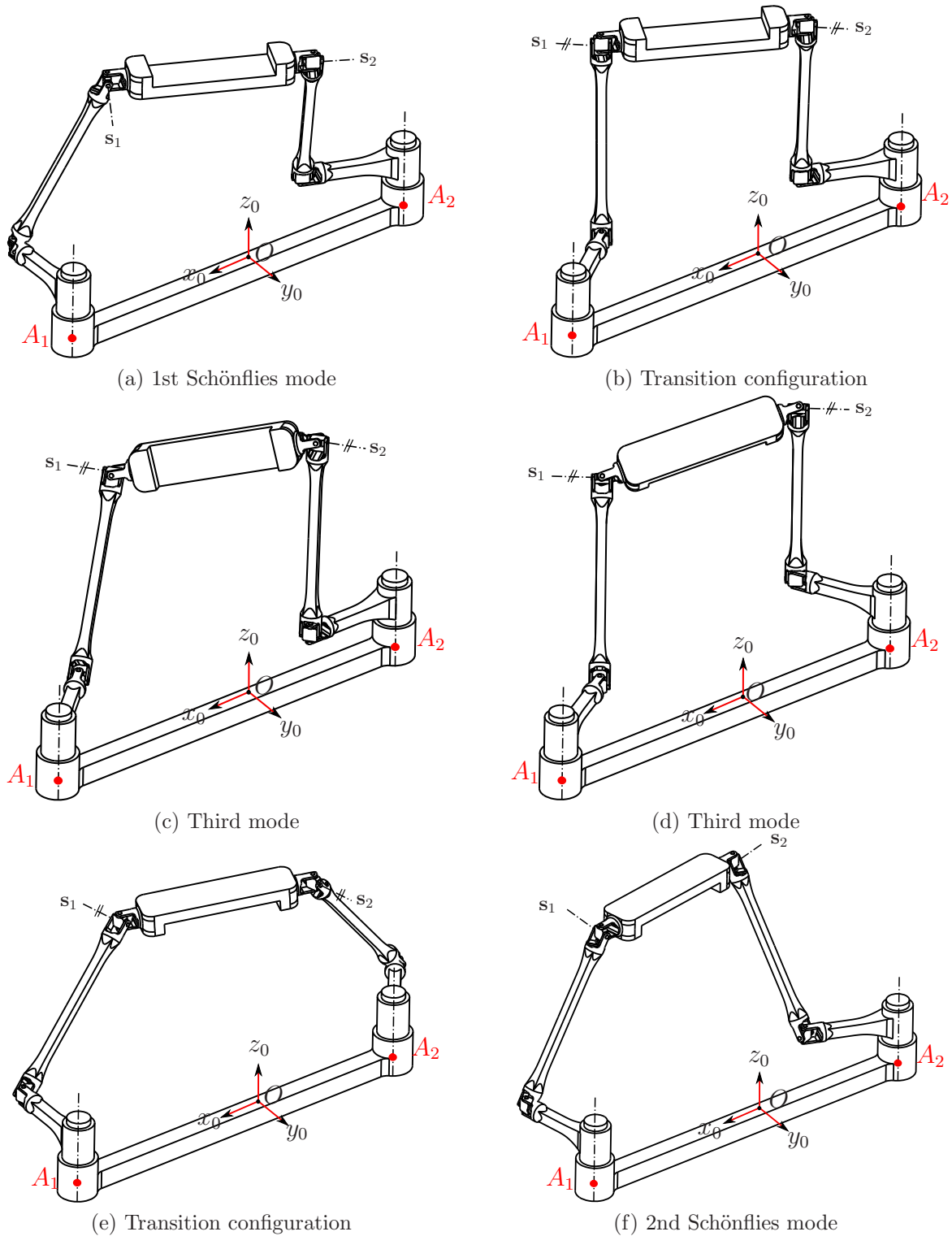

Figure 8: Transition from the 1st Schönflies mode to the 2nd Schönflies mode via the third mode that contains self-motion.

- [7] Amine, S., Masouleh, M., Caro, S., Wenger, P., and Gosselin, C. (2012). “Singularity Conditions of 3T1R Parallel Manipulators with Identical Limbs Structures.”, *Journal of Mechanisms and Robotics*, **4**(1), pp. 011011.
- [8] Amine, S., Caro, S., Wenger, P., and Kanaan, D. (2012). “Singularity Analysis of the H4 Robot Using Grassmann-Cayley Algebra.”, *Robotica*, **30**(7), pp. 1109-1118.
- [9] Qinchuan Li and Jacques M. Herve. (2009). “Parallel Mechanisms with Bifurcation of Schönflies Motion.”, *IEEE Transactions on Robotics*, **25**(1), pp. 158–164.
- [10] Chung-Ching Lee and Jacques M. Herve. (2005). “Isoconstrained Parallel Generators of Schönflies Motion.”, *Journal of Mechanisms and Robotics*, **3**(2), pp. 021006-1–021006-10.
- [11] Husty, M., Pfurner, M., Shröcker, H-P., and Brunthaler, K. (2007). “Algebraic Methods in Mechanism Analysis and Synthesis.”, *Robotica*, **25**(6), pp. 661–675.
- [12] Schadlbauer, J., Walter, D.R., and Husty, M. (2014). “The 3-RPS Parallel Manipulator from an Algebraic Viewpoint.”, *Mechanism and Machine Theory*, **75**, pp. 161–176.
- [13] Nurahmi, L., Schadlbauer, J., Husty, M., Wenger, P., and Caro, S. (2015). “Motion Capability of the 3-RPS Cube Parallel Manipulator.”, In: Lenarčič, J and Khatib, O., *Advance in Robot Kinematics*, Springer, pp. 527–535.
- [14] Nurahmi, L., Schadlbauer, J., Husty, M., Caro, S., and Wenger, P. (2015). “Kinematic Analysis of the 3-RPS Cube Parallel Manipulator.”, *Journal of Mechanisms and Robotics*, **7**(1), pp. 011008-1–011008-11.
- [15] Nurahmi, L., Caro, S., and Wenger, P. (2015). “Operation Modes and Self-motions of a 2-RUU Parallel Manipulator.”, In: Bai, S and Ceccarelli, M, *Recent Advances in Mechanism Design for Robotics*, **33**, Springer, pp. 417–426.
- [16] Xianwen Kong. (2012). “Type Synthesis of Variable Degrees-of-Freedom Parallel Manipulators with Both Planar and 3T1R Operation Modes.”, *Proceedings of the ASME 2012 International Design Engineering Technical Conference and Information in Engineering Conference*, Chicago, USA, August 12–15.
- [17] Schadlbauer, J., Nurahmi, L., Husty, M., Wenger, P., and Caro, S. (2013). “Operation Modes in Lower-Mobility Parallel Manipulators.”, In: Kecskeméthy, A and Geu Flores, F, *Interdisciplinary Applications of Kinematics*, **26**, Springer, pp. 1–9.
- [18] Schadlbauer, J., Husty, M., Caro, S., and Wenger, P. (2013). “Self-motions of 3-RPS Manipulators.”, *Frontiers of Mechanical Engineering*, **8**(10), pp. 62–69.

- [19] Coste, M and Demdah, K. (2015). “Extra Modes of Operation and Self-motions in Manipulators Designed for Schönflies Motion.”, *Journal of Mechanisms and Robotics*, **7**(4), pp. 41020–41026.
- [20] Xianwen Kong. (2014). “Reconfiguration Analysis of a 3-DOF Parallel Mechanism Using Euler Parameter Quaternions and Algebraic Geometry Method.”, *Mechanism and Machine Theory*, **74**, pp. 188–201.