



HAL
open science

Monitoring of Gas Permeability and Water Content in Large Concrete Structures: a New Method based on Pressure Pulse Testing

Franck Agostini, Timothée Clauzon, Alexis Courtois, Frédéric Skoczylas

► To cite this version:

Franck Agostini, Timothée Clauzon, Alexis Courtois, Frédéric Skoczylas. Monitoring of Gas Permeability and Water Content in Large Concrete Structures: a New Method based on Pressure Pulse Testing. TINCE Conference, Sep 2016, Paris, France. ⟨hal-01713909⟩

HAL Id: hal-01713909

<https://hal.science/hal-01713909v1>

Submitted on 14 Feb 2024

HAL is a multi-disciplinary open access archive for the deposit and dissemination of scientific research documents, whether they are published or not. The documents may come from teaching and research institutions in France or abroad, or from public or private research centers.

L'archive ouverte pluridisciplinaire **HAL**, est destinée au dépôt et à la diffusion de documents scientifiques de niveau recherche, publiés ou non, émanant des établissements d'enseignement et de recherche français ou étrangers, des laboratoires publics ou privés.



HAL Authorization



Full paper Submission, TINCE-2016 Paris (France), September 5th – 9th, 2016



Monitoring of Gas Permeability and Water Content in Large Concrete Structures: a New Method based on Pressure Pulse Testing

Franck Agostini¹, Timothée Clauzon², Alexis Courtois³ and Frédéric Skoczylas⁴

¹ Associated Prof. Dept. of Civil Engineering, Centrale Lille, Villeneuve d'Ascq, France
(franck.agostini@ec-lille.fr)

² Engineer, EDF DTG, Lyon, France

³ Expert, EDF DTG, Lyon France

⁴ Professor, Dept. of Civil Engineering, Centrale Lille, Villeneuve d'Ascq, France

Introduction

EDF is steadily progressing on the quality of structural health monitoring by taking advantage of the latest innovations in sensors. The recent construction of the VeRCoRs mock-up (at EDF Lab Les Renardières, near Fontainebleau, France) enables to highlight significant advances in temperature, strain and moisture monitoring in concrete of the inner pre-stressed containment. The “gas-pressure-pulse-decay” (i.e. “pulse”) technology has been setup in this structure since September 2014, in order to measure the concrete water saturation. The pulse technique is not only a new sensor but also a strategy of measurements. The main idea behind the design of this new technique is to use the strong link between the concrete effective gas permeability and its water saturation. The main goal of this presentation is therefore to present the first results obtained in laboratory and in-situ. Despite usual concrete heterogeneities, the relative gas permeability of the VeRCoRs concrete can be obtained from lab experiments. They have been used *in-situ* to evaluate the water saturation evolution in deep walls as well as useful information on the concrete quality. The first results and their analysis which have been obtained for the VeRCoRs mock-up are described in the present paper.

Application of the new method

Context

Electricité de France (EDF) has operated 58 nuclear power plants in France for an average time of 30 years; they are expected to provide electricity for 15 to 40 years more.

A significant part of safety assessment of nuclear structures relies on validated numerical simulations and calculations which also have to be compared to results of in-situ monitoring from which three major properties of concrete must be identified: thermic, hydric and mechanic. They are necessary to check the structure integrity with time and are linked to the long and short term shrinkage. The new technique (pulse method) has been designed to measure the *in situ* apparent gas permeability, and to infer water saturation within the concrete structure from this

permeability measurement. This is a rather complex process as there is no available device allowing direct measurements of *in situ* water saturation of concrete.

Probe design

The principle of the “pulse” method relies on local effective gas permeability measurements in the structure. The relation between the concrete’s water saturation (or moisture content) and its effective gas permeability is identified with tests performed in the laboratory on the concrete. Samples of the latter are previously obtained during the concreting operations since, before them, pulse probes are put in the structure where permeability (i.e. water saturation) will be locally measured (figure 1). A gas injection disposal is installed close to the structure; this allows the gas pressure to be continuously recorded during the gas injection test within the probes [LIU13]. The gas flow geometry has to be known to use Darcy’s law and to further analyze the pressure measurements. Hence it was chosen to use a cylindrical stainless steel porous probe which will be connected via a stainless steel capillary tube to a gas injection device (figure VerCoRs). This device must allow several probes to be used and to accurately measure the gas pressure in the circuit. A picture of a probe is given in figure 2.

This probe is then put inside the concrete structure and fixed between reinforcing bars (figure 2). As mentioned before the pulse sensor is connected to a gas injection device presented in figure 3. In situ test control and data acquisitions are carried out with a computer and Labview® software. The whole disposal has been installed at Moret sur Loing (France) where EDF has designed and built the VerCoRs mock up.

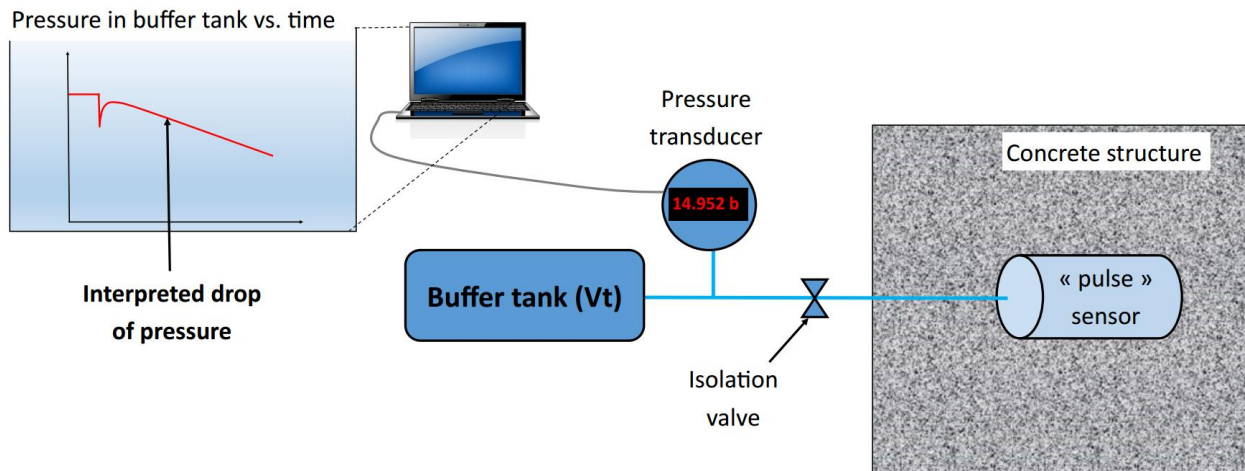

Figure 1: Schematic diagram of the “pulse” technic



Figure 2: pulse probes before casting of a reinforced concrete structure.

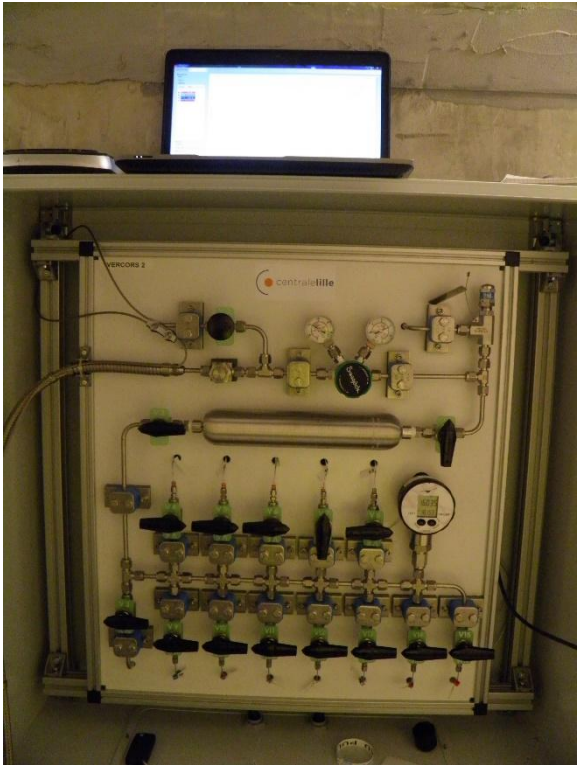

Figure 3: gas injection device allowing to connect 12 “pulse” sensors and computer for data recording and processing.

Liquid saturation determination through “Pulse-Test”

The steady state flow cannot be assumed for the permeability calculation in the case of in situ measurements. Due to the size of the structure the steady state may not be actually reached in a reasonable time, or, if it is reached, the geometry of the flow in the investigated volume may become too complex, compared to the assumed cylindrical one. The “pulse test” protocol consists in rapidly increasing the pressure in the “pulse sensor” (including the buffer tank),

halting the injection and then measuring the fall in pressure caused by the flow (see figure 1). The geometry of the flow is assumed to be cylindrical, while the investigated radius around the sample remains of the same order as the length of the chamber. For a cylindrical flow, in steady state conditions, Darcy's law can then be used to determine effective permeability. The mean volume flow rate (Q_m) is calculated through equation (1) knowing the volume of the buffer tank and of the piping (V_t) and assuming that the gas is ideal and the test realized in isothermal conditions. ΔP is the variation of gas pressure in the buffer tank during the time Δt , and P_m is the mean pressure in the tank during this same time.

$$Q_m = \frac{V_t \cdot \Delta P}{\Delta t \cdot P_m} \quad (1)$$

The effective permeability (K_e) can then be linked to this volume flow rate from equation (2) ([KAC10]). This effective permeability is also an apparent permeability since it is not corrected from the Klinkenberg effect ([DAN99]).

$$Q_m = \frac{K_e \pi}{\mu} \frac{P_i^2 - P_0^2}{P_i} \frac{L}{\log \frac{R_0}{R_i}} \quad (2)$$

Where L is the length of the chamber, P_i the pressure in the chamber, P_0 the atmospheric pressure, R_i the radius of the chamber and R_0 the influence radius (i.e. the radius at which pressure is equal to P_0). In unsteady state condition, which is the case for the "pulse" protocol, the radius R_0 after a given time of testing, is indefinite. Indeed, it depends on both effective permeability and water saturation (through available porosity), which are the unknowns of the problem. Numerical simulations are then used to determine the drop of gas pressure in the buffer tank for a given couple of parameter K_e and S_w . Experimental drop of pressure are compared to simulated one to deduce both K_e and S_w .

The evolution of pressure around the chamber as a function of time has been obtained using a one-dimensional (1D) finite difference scheme has been built. The main equation is a diffusion equation type, which is nonlinear, due to the high gas compressibility, and is written for a cylindrical flow in equation (3):

$$\frac{\partial^2 P}{\partial r^2} + \frac{1}{r} \frac{\partial P}{\partial r} = \frac{\mu \cdot \phi \cdot (1 - S_w)}{P \cdot K_g} \frac{\partial P}{\partial t} \quad (3)$$

r ranges from R_i to R_0 . For $t=0$, P is equal to atmospheric pressure for $r > R_i$ and equal to P_i for $r=R_i$, where P_i is the pressure applied to the pulse sensor at the beginning of the test.

The pressure in the device is deduced by calculating the flow through the wall of the chamber deduced from mass balance equation and Darcy's law [LYD93]:

$$\frac{dP_i(t)}{dt} = \frac{K_g \cdot S}{\mu \cdot V_t} \cdot P_i(t) \cdot \frac{\partial P(R_i, t)}{\partial r} \quad (4)$$

where V_t is the volume of the chamber and the tube, S is the surface of the chamber wall, $P_i(t)$ is the pressure in the chamber at the instant t , and R_i is the radius of the chamber.

The simulation program has been validated using approximate analytical models of non-stationary single reservoir gas permeability tests with radial flow through hollow cylindrical samples [KAC10].

When the material has been previously characterized, the porosity and the relationship between effective permeability (K_e) and liquid saturation S_w are known. The drop of pressure in the chamber can then be simulated for a liquid saturation which varies from 0 to 100% by steps of 1%. This simulation assumes isothermal test conditions. However, during the first times of the test, the simulation cannot reproduce experimental conditions, as fast initial gas compression leads to thermal variations. The whole drop of pressure curve is then not suitable for test

interpretation. It is necessary to wait for initial thermal disturbances to dissipate before calculation. The volume flow rate and then the pressure variations are small enough to assume that once passed this first disturbed phase, the system is in isothermal conditions. The lap of time necessary to consider isothermal conditions depends on experimental conditions and employed material (specific heat, heat conductivity...). Preliminary tests allow the evaluation of the length of the disturbed period. This delay is designed as t_{etd} (time at the end of thermal disturbances). Finally, it is the comparison of the simulated and real pressure variation in the pulse sensor for $t > t_{etd}$ which is used for pulse interpretation.

The efficiency of this method to determine in situ water saturation has first been study through an experimental laboratory campaign.

Characterization campaign of the concrete VerCoRs

Porosity, effective permeability and water saturation measurements

The characterization campaign aims at determining the average porosity and the relationship between effective permeability and water saturation of the studied mortar. The 65x30mm samples were used for this purpose. After coring and cutting, the mass of the samples is measured and is assumed as the saturated mass M_{sat} . The apparent volume (V_{app}) is also measured. The samples are then stored in controlled relative humidity, at 98, 92, 85, 75, 70, 59, 43 and 11% of RH, until mass stabilization. The stabilized mass at $x\%$ of RH is referenced as $M_{x\%}$. The effective gas permeability, for a stabilized water saturation of $x\%$ ($K_{eff,x\%}$) is measured under steady state flowing conditions. The material and methodology used for effective permeability measurement, and validated by more than 20 years of studies, is detailed in [LOO02][MUA76][SKO95][DAN99]. The upstream gas pressure is equal to 1.6 MPa and the downstream pressure is equal to atmospheric pressure, 0.1 MPa. At this stage, the liquid saturation of the samples is still unknown. Samples are then dried at 60°C, until mass stabilization and the dried mass (M_{dry}) is measured. This value allows calculating the porosity (ϕ) of the samples and the liquid saturation obtained for a relative humidity of $x\%$ ($S_w(x\%)$) using relations (5) and (6). The effective gas permeability for a liquid saturation of 0% ($K_{eff,0\%}$) is measured. For each sample, the relative gas permeability for the obtained water saturation ($K_{rg,x\%}$) is calculated according to relation (7).

$$\phi = \frac{M_{sat} - M_{dry}}{V_{app}} \quad (5)$$

$$S_w(x\%) = \frac{M_{x\%} - M_{dry}}{M_{sat} - M_{dry}} \quad (6)$$

$$K_{rg,x\%} = \frac{K_{eff,x\%}}{K_{eff,0\%}} \quad (7)$$

The experimental plots $K_{rg,x\%}$ versus saturation, are then fitted using a modified Van Genuchten - Mualem model, allowing to estimate the relative permeability for any liquid saturation. This is done to get a continuous function K/S_w to be introduced in numerical simulation.

It can be objected that the concrete tested from samples, even if coming from real in-situ batches, may not behave like the structural concrete. However as the saturation measurement is not directly evaluated, whatever the measurement method, every result will be based on laboratory investigations carried out on witness material. The real material can be obtained only by coring the structure which is obviously impossible for storage ones. Even if it was possible,

the concrete property spatial dispersion does not ensure that the properties of the cored sample are homogeneous into the whole structure. As a consequence 16x32 specimens were taken from different concrete truck mixers and then cored into smaller samples in order to at least verify the material homogeneity and the results reliability.

Results from lab experiments

The average porosity measured on 16 samples is equal to 14%, with a standard deviation of 0.9. The effective permeability measured on dry samples averages $4.0 \times 10^{-17} \text{ m}^2$. Figure 4 presents the water saturation of samples according to the RH storage conditions. As expected, the relatively high W/C of VeRCoRs concrete (0.52) ratio leads to a large porous network and an important desaturation even for high RH. Liquid saturation is around 80% for 98% of RH, which indicates that 20% of the pores have a radius larger than $0,1 \mu\text{m}$. Figure 5, represents the experimental K_{rg} plots and the modified Van Genuchten - Mualem fitting with corresponding parameters.

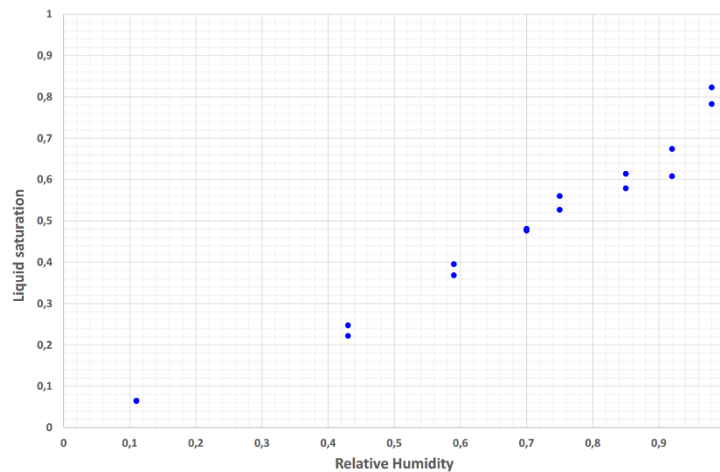

Figure 4: Relation between relative humidity and liquid saturation for VeRCoRs concrete.

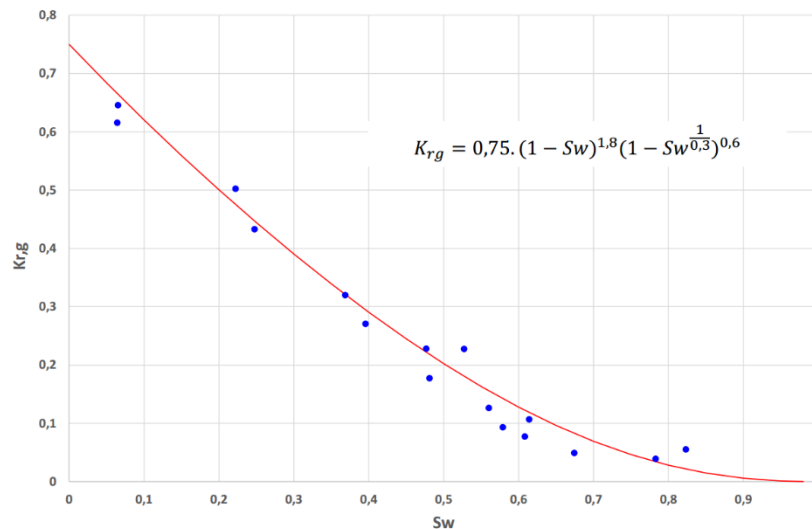

Figure 5 : experimental $K_{rg}(S_w)$ plots on VeRCoRs concrete and modified Van Genuchten - Mualem fitting with corresponding parameters.

In situ results

A group of 18 pulse sensors have been implemented in the mock-up. They allow to obtain four saturation profiles. In the first lift of the containment structure, two profiles have been realized using six sensors for each one (for the 1st lift, the thickness of the wall is equal to 600mm). In the 14th lift (400mm of thickness), two profiles have been realized using three sensors for each one. The concrete of the structure has been characterized through a laboratory study. 16 samples cored in 16x32 specimens were used to determine the $K_{\text{eff}}(S_w)$ relationship of this material. Samples were cored in eight 16x32 specimens.

The measures performed in situ in October 2014 led to the pressure drop curves presented in figure 6 (for one of the profiles of the 1st lift). The interpretation of those results allowed to calculate a liquid saturation ranging from 0.84 to 0.98 see figure 7 and 8. It seems difficult to validate these results with a high level of confidence, due to the lack of an alternative method to measure in situ water saturation in concrete structures. However, those values are consistent with those available in the literature addressing drying behavior of massive concrete pieces without hydric exchanges with the environment. For example, Yssorche [YSS99], has shown that, after one year, the internal relative humidity of concrete protected from atmosphere exchanges could vary from 88 to 99%, for concrete having a W/C ratio ranging from close to 0.44 to 0.59 (which is the case of the concrete set in place in VerCoRs, where W/C=0.52).

In situ results show a good reproducibility, but the water saturation profile is quite different from the one expected for a thick wall during drying. This result may be due to the watering of the surfaces of the VerCoRS mock-up during its erection, which was undertaken to prevent any early drying involving lower shrinkage and creep after the prestressing of the cylinder. The expected accuracy of this measurement technic lies in the fact that all previous studies have shown that gas permeability mainly depends on the moisture content [CHE11]. There is no hysteresis effect due to climate history, sensitivity to the amount of salts in the pore solution, and the effect of external temperature is limited (especially in the core of a massive concrete structure). Nevertheless, the accuracy on gas permeability measurement largely depends on the *in situ* conditions, i-e length and material of the tube used to connect the probe to the measurement device, thermal insulation of the measurement device, accuracy of the pressure manometer... The quality of concrete casting is also of importance. The concrete characterization laboratory study has shown that the results (porosity, permeability, desorption isotherm...) obtained from different 16x32 samples were quite reproducible. Nevertheless, it is impossible to check the reproducibility of the concrete casted around the different sensors.

Additional measures will be performed regularly to test the reproducibility of the measures and the sensitivity of in situ testing protocol to varying climatic conditions. Nevertheless, the feasibility of the pulse test protocol has been assessed, in an industrial context.

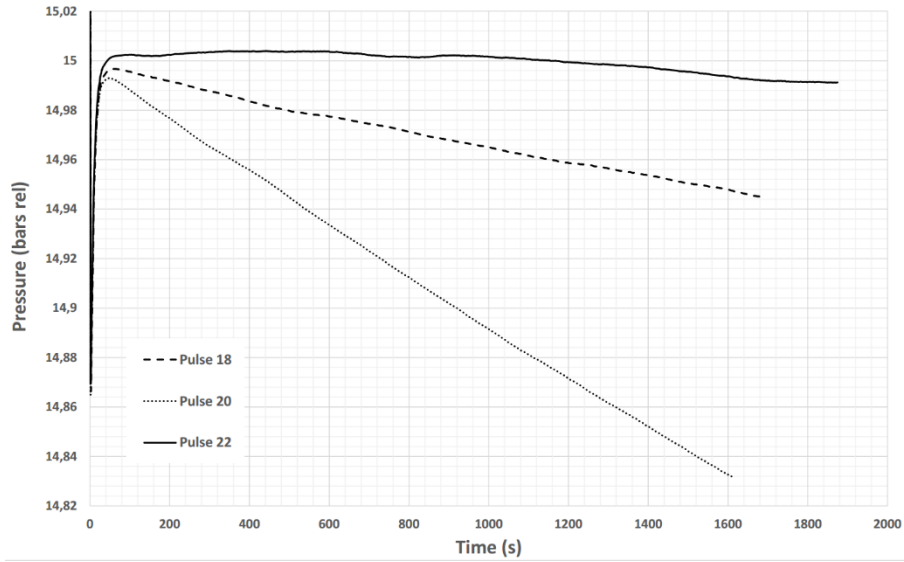

Figure 6 : pressure drops recorded *in situ* on three sensors of the 1st lift of VeRCoRs mock-up (October 2014).

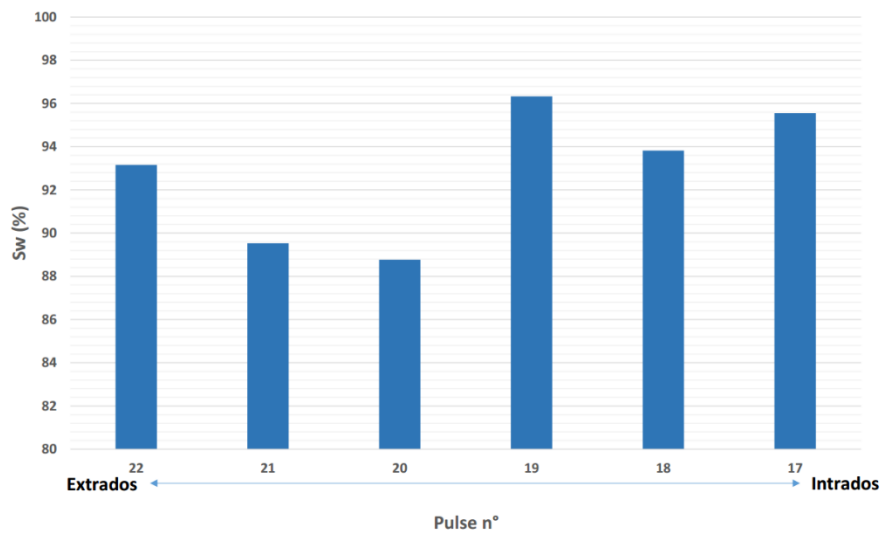

Figure 7 : interpreted water saturation from “pulse” tests along a profile of the 1st lift of VeRCoRs mock-up on October 2015.

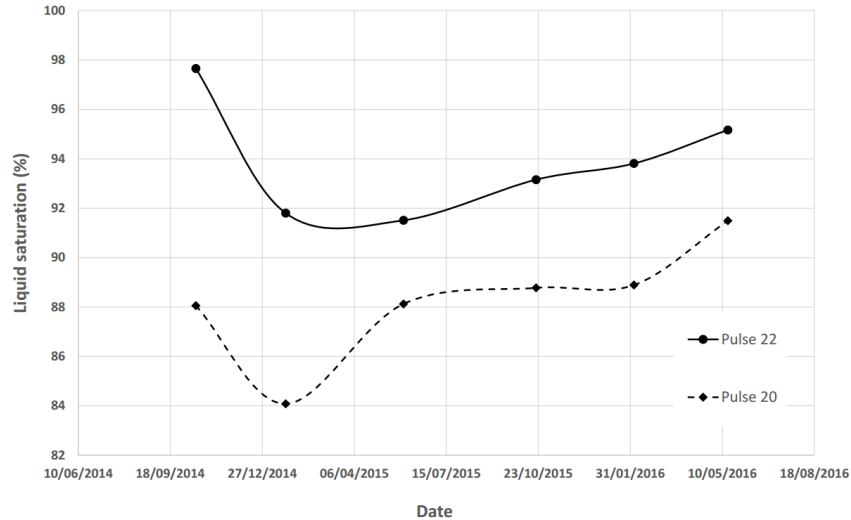

Figure 8 : evolution of interpreted water saturation of “pulse” n°20 et n°22 of the 1st lift of VeRCoRs mock-up from October 2014 to May 2016.

Conclusion

New devices to measure apparent gas permeability and water saturation within thick concrete structures have been designed, build and tested on the VeRCoRs reduced scale containment mock-up, in France. This method is the result of an effective transfer of technology from laboratory experiment to *in situ* structures monitoring. The first measurements campaigns have clearly shown the “pulse” method efficiency and its consistency with expected initial water saturation of *in-situ* concrete. The *in-situ* measurements reveal a good reproducibility despite no real evidence of a concrete drying around the “pulse” probes up to now. This is consistent with the usual kinetics of this phenomenon for such large structures. Some saturation discrepancies are sometimes observed. As they cannot be attributed to the concrete drying, they can be assumed to come from the natural concrete dispersion or from micro-cracking. This method also reveals sensitive to any change in water saturation that was one of the main goal of the design of such methods.

Additional research will be conducted to assess the heterogeneity of concrete properties in large structures. The effect of casting operations on local variations of W/C and its influence on self-desiccation, porosity and permeability would allow a significant improvement on the interpretation of the results. In parallel to VeRCoRs project experiments, a set of pulse sensors have been implemented in a thick wall of the aircraft shell of Flamanville 3 EPR, France, to demonstrate the feasibility on a real nuclear site and to test this technique on a full scale building.

References

- [LIU13] Liu J., Agostini F., Skoczylas F., (2013), “From relative gas permeability to in situ saturation measurements”, *Construction and Building Materials*, Volume 40, March 2013, Pages 882-890, ISSN 0950-0618, <http://dx.doi.org/10.1016>.

Corresponding author: alexis.courtois@edf.fr