



HAL
open science

Improvement of a Series-Parallel Hybrid Electric Vehicle Architecture

Bilal Kabalan, Emmanuel Vinot, Yuan Cheng, Rochdi Trigui, Clément Dumand

► **To cite this version:**

Bilal Kabalan, Emmanuel Vinot, Yuan Cheng, Rochdi Trigui, Clément Dumand. Improvement of a Series-Parallel Hybrid Electric Vehicle Architecture. VPPC, Dec 2017, BELFORT, France. hal-01713421

HAL Id: hal-01713421

<https://hal.science/hal-01713421v1>

Submitted on 20 Feb 2018

HAL is a multi-disciplinary open access archive for the deposit and dissemination of scientific research documents, whether they are published or not. The documents may come from teaching and research institutions in France or abroad, or from public or private research centers.

L'archive ouverte pluridisciplinaire **HAL**, est destinée au dépôt et à la diffusion de documents scientifiques de niveau recherche, publiés ou non, émanant des établissements d'enseignement et de recherche français ou étrangers, des laboratoires publics ou privés.

Improvement of a Series-Parallel Hybrid Electric Vehicle Architecture

Bilal Kabalan*[†], Emmanuel Vinot*, Yuan Cheng[†], Rochdi Trigui*, Clément Dumand[†]

*IFSTTAR

25 Av. Francois Mitterrand

69675 Bron - France

[†]Groupe PSA

Centre Technique Vélizy A, Case courrier VV1415

Route de Gizy, 78943 Vélizy-Villacoublay Cedex

Email: bilal.kabalan@mpsa.com

Abstract—A simple version of a Series-Parallel Hybrid Electric Vehicle (SPHEV) powertrain was proposed and studied in previous work. It consists of 2 Electric Machines (EM) mounted on the engine shaft and separated by a clutch. It is a relatively simple architecture that allows vehicle operation in pure electric, series hybrid and parallel hybrid modes. However, this architecture was proven to be less efficient than a reference Power-Split SPHEV architecture: the Toyota Hybrid System (THS). As a continuation, this paper investigates the potential of improvement of the simple SPHEV by the addition of gears and a gearbox. Two new variants of SPHEVs are therefore proposed. The three versions of SPHEVs and the reference THS are sized on a global optimal manner and compared. Results show that one variant of the simple SPHEV can have comparable fuel consumption to the THS.

I. INTRODUCTION

A Hybrid Electric Vehicle (HEV) powertrain combines a conventional engine-based traction system with a battery electric traction system. The connection between the two systems can be made through different means, resulting in different HEV architectures. One can recognize 3 main categories between those proposed by the manufacturers: series, parallel and series-parallel. For more explanation about the difference between these architectures, one can refer to [1].

According to [1], series-parallel architectures (SPHEV) combine the advantages of series and parallel, but they have relatively a more costly design and complicated control. The most common SPHEV powertrain is the power-split SPHEV that uses a planetary gear (PG) as a power split unit. The Toyota Hybrid System THS is the reference power-split SPHEV in this study. Like any parallel architecture, this system has a torque degree of freedom (Dof) due to the fact that more than one torque actuator can provide the required torque to the wheels. The added value of the PG is that it adds a speed Dof by decoupling the engine speed from the wheels speed. Those double Dof allow moving the operating points of the powertrain on its high efficiency area. The cost of this double freedom is that the power going to the wheels should be always split between a parallel path and a series path, the latter having a lower efficiency due to the added energy conversion stages. Even though, power-split SPHEV remain the most efficient mass produced HEV [1], [2], [3], [4].

Nevertheless, other SPHEVs can be realized without a planetary gear system. A simple SPHEV powertrain with no PG was studied in [5] (Fig. 1). It consists of 2 Electric Machines (EM) mounted on the engine shaft and separated by a clutch. It is relatively a simple architecture that allows vehicle operation in pure electric, series hybrid or parallel hybrid mode. Its advantage is that it can operate in a pure parallel mode avoiding the losses of the series path. However, replacing the PG by a simple mechanical connection implies that the speeds of the components are all imposed by the wheels speed. Hence, the speed Dof is lost and operating the system in its best efficiency areas is more difficult compared to power-split SPHEV. In addition, depending on the components characteristics and sizing (maximum torque, speed ...), the vehicle needs constrain the powertrain to operate sometimes in series or parallel modes even when they have a relatively low efficiency. In fact, it is quite impossible to cover the complete vehicle speed range through an engine connected to the wheels with a fixed gear ratio. This simple SPHEV architecture has thus been proven to be less efficient than the power-split SPHEV [6].

The aim of this paper is to investigate the potential of improvement of the simple SPHEV. Many possibilities of gears and gearbox addition can be considered. One can think of adding a gear between the final shaft and each component (ICE and 2EM), or adding a gearbox to the powertrain, with different possible number of gears and different possible locations. In the same context, Denso Corporation proposed an architecture with a gear on each EM and a gearbox of two ratios [7]. Such architecture, functionally represented in (Fig. 3) may improve the efficiency of the simple SPHEV architecture while keeping the transmission a relatively simple one.

In a first time, this paper proposes to make a fair comparison between THS and three different SPHEV architectures:

- SPHEV 1: the simple SPHEV architecture in which the engine and the electric machines are on the same shaft (Fig. 1)
- SPHEV 2: a SPHEV with one added gear between the final shaft and each component (Fig. 2)
- SPHEV 3: a SPHEV with a gear on each EM and a 2-speed gearbox between the 2 EMs (Fig. 3). SPHEV 3

has the same functionality of the architecture proposed by Denso Corporation in [7].

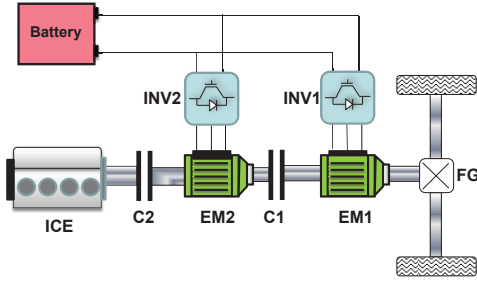

Fig. 1. SPHEV 1

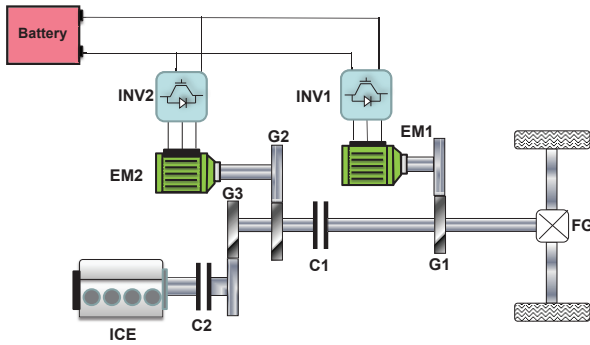

Fig. 2. SPHEV 2

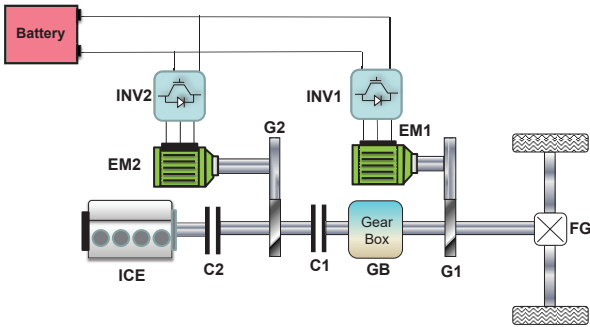

Fig. 3. SPHEV 3

The comparison between HEV architectures has always been performed by researchers and automakers and remains an essential step in the early design phases of HEV powertrains. However, such non power-split SPHEV architectures are seldom studied in the literature. The first contribution of this paper is that it is putting more attention on those architectures and is trying to investigate if they can achieve comparable or better results than the power-split ones.

On another hand, this comparison is not an obvious task because of the complexity of the design problem. In fact, the efficiency of the powertrain does not only depend on the architecture, but also on different other parameters (sizing variables, control variables, driving profiles). Any comparison

not performed with a global perspective to this design problem can easily become a particular case and therefore a biased comparison. The second contribution of this paper is that the comparisons are done with a global optimal manner that ensures unbiased results. For each architecture, an optimal sizing procedure is performed using the global optimal design process proposed in [8].

The sizes of the components and the gear ratios are the optimization variables. A global optimization algorithm varies those variables to minimize two objectives that are the fuel consumption and the battery size. The fuel consumption is calculated for a representative driving cycle, along which the choice of modes (electrical, parallel or series mode) and other control variables are decided by a global optimal energy management strategy.

Section II of this paper explains the methodology used to perform the comparison. Section III presents the results and proposes a closer look on the powertrain operation in order to understand the efficiency differences between the architectures.

II. METHODOLOGY

To guarantee a fair comparison between the architectures, an optimization process is performed beforehand for each of them to ensure that they are compared based on their optimal potential. Each architecture is modeled using the longitudinal dynamics laws. Maps are used to model the ICE and the EM. A classical equivalent electric circuit model is used for the battery cells. The architecture equations and the component models are fixed. However the sizes of the components (ICE, 2EM and battery) and the gear ratios are not fixed: they are the sizing variables in this sizing optimization problem. Once those sizing variables are chosen, the powertrain can be run on a driving cycle during which some instantaneous decisions should be made, like the choice of operating mode. These are the control variables in this control optimization problem. The optimization process has therefore 2 levels (Fig.4): an upper level sizing optimization and a lower level control optimization.

A. Upper level sizing optimization

The optimization variables here are the sizing variables of the powertrain model:

- the maximum power of the ICE and the 2 EMs
- the number of battery modules in series
- the ratios of the gears, if existing
- the ratios of the gearbox, if existing

The architectures can have up to 9 sizing variables; therefore the design space of this optimization can have up to 9 dimensions. The genetic algorithm NSGA-II [9], [6], [10] is used as the optimization algorithm. NSGA-II performs the exploration of this design space and generates a Pareto front in function of the optimization objectives. Two objectives are considered in this paper, the fuel consumption and the number of battery modules in series. The later is an indicator of the battery stored energy.

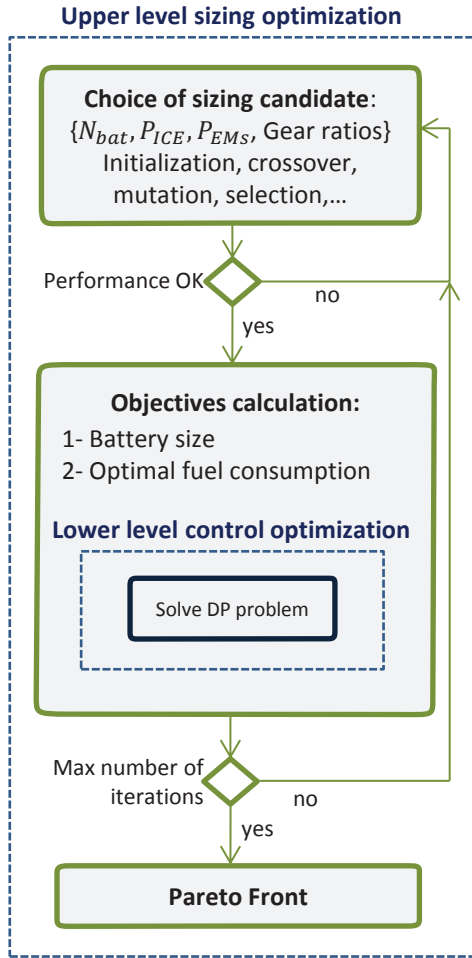

Fig. 4. Optimization process

The role of the NSGA-II is to choose the sizing candidate to be assessed (set of values for the sizing variables). Based on the evolutionary theory, NSGA-II starts with an initial population of sizing candidates, then it tries to create better generations (by crossover, mutation, selection...) until a maximum number of iterations is reached. An explanation of this process can be found in [10].

When the genetic algorithm chooses a sizing candidate to be assessed, the chosen sizing values are directly applied to the powertrain model. For the ICE and 2 EM, a scaling is performed for the maximum torque curves and the fuel consumption or efficiency maps. The inertia and weight are also impacted. For the battery, which is composed of cells coupled in series, the scaling is performed by changing the number of cells in series. The battery characteristics (voltage, maximum power, stored energy) that depend on this number are directly updated. The gear ratios are also changed to the sized values. At this stage, the candidate sizing chosen by NSGA-II is now a modeled powertrain that is ready for assessment.

A performance test is performed to insure that the candidate sizing respects the following constraints:

- the acceleration time from 0 to 100 km/h: $t_{0 \rightarrow 100} <$

10.1s

- the maximum speed of the vehicle on a flat road: $V_{max} > 179 \text{ km/h}$
- the overtaking capability at 80 km/h: $t_{80 \rightarrow 120} < 7.5 \text{ s}$

If the sizing candidate passes this test, it is sent to the next step of objectives calculation. The first objective, the number of battery modules is one of the sizing variables and does not need to be calculated again. The second objective, the fuel consumption can be assessed by running the powertrain model on a known in advance driving cycle. Here, a control optimization problem arises.

B. Lower level control optimization

The fuel consumption is strongly dependent on the instantaneous choice of control variables during the driving cycle. For the 3 proposed SPHEVs, the first control variable is the choice of operating mode. In fact, a given speed and power demand of the vehicle can be accomplished by the powertrain through different possible operating modes:

- electrical mode (C2 open and C1 open or closed)
- parallel hybrid mode (C1 and C2 closed)
- series hybrid mode (C1 open and C2 closed)

In addition, the power sharing between EM1 and EM2 in electric mode, the power sharing between the ICE, EM1 and EM2 in parallel mode, and the gear choice in the gearbox are other control variables.

This control problem can be solved by different methods, or Energy Management Strategies (EMS). They differ in their optimality, computation time and ability to be implemented or not in real time vehicle operation. In this work, the chosen EMS is the Dynamic Programming (DP) which guarantees the global optimal fuel consumption of each candidate [11], [12], [13]. The choice of DP implies that the architectures are compared based on their optimal potential of fuel saving and preserves consequently the fairness of comparison.

The global optimal fuel consumption calculated by DP is sent back to the upper level where the genetic algorithm continues the optimization process until a maximum number of generations is reached. Pareto front of the fuel consumption versus the number of battery modules can be plot for each architecture. This is presented in the following section.

III. COMPARISON OF THE ARCHITECTURES

The THS and the 3 proposed SPHEV architectures are optimized using the previously presented optimization process. The vehicle characteristics and components correspond to a middle class HEV and can be found in Table I. The reference maps of EM1 and ICE before sizing are shown in Fig. 5. The sized maximum powers chosen for the ICE and EMs are used to calculate the scaling factor for each component. The torque and losses are multiplied by this scaling factor to generate the new sized maps.

The assessment of the powertrains is done in mixed driving conditions. The fuel consumption in the optimization process

TABLE I. COMPONENTS SPECIFICATIONS

Component	Specification
Engine	Gasoline, Atkinson
EM1	Permanent Magnet Synchronous Motor
EM2	Permanent Magnet Synchronous Motor
Battery	Nickel-metal hydride, 1.2V cell
Gearbox	2-speed gearbox
Gears	all gears are parallel axis helical gears with a 98% efficiency
Vehicle	middle class HEV

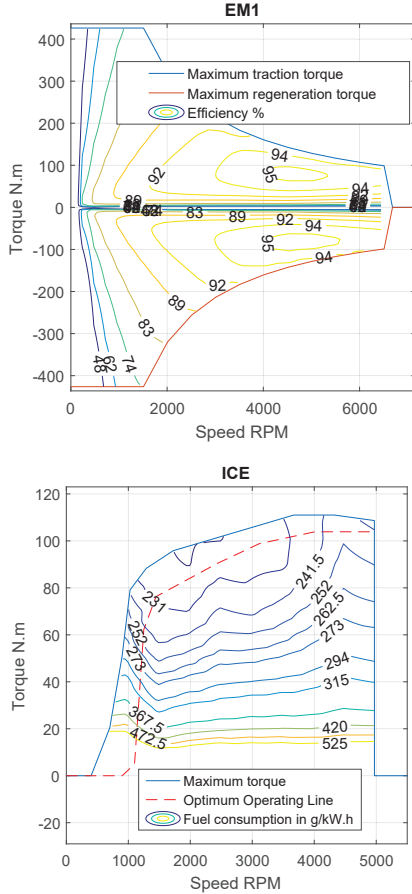

Fig. 5. EM1 and ICE maps before sizing

is considered to be a weighted average of the fuel consumption in urban, rural road and highway conditions:

$$FC = \alpha.FC_{urban} + \beta.FC_{road} + \gamma.FC_{highway} \quad (1)$$

Where the α , β and γ are coefficients calculated from the mean traveled distance in urban, rural road and highway conditions by the French population. These values are respectively 0.4, 0.3 and 0.3 [14].

The Pareto fronts obtained at the end of 500 iterations in the optimization process are presented in Fig. 6.

The first interpretations of the Pareto fronts are:

- 1) THS has globally a better fuel consumption than SPHEV 1. This confirms the results found in [6] and can be explained by the lack of speed degree of freedom (Dof) in SPHEV 1 and the increased usage of the series mode.

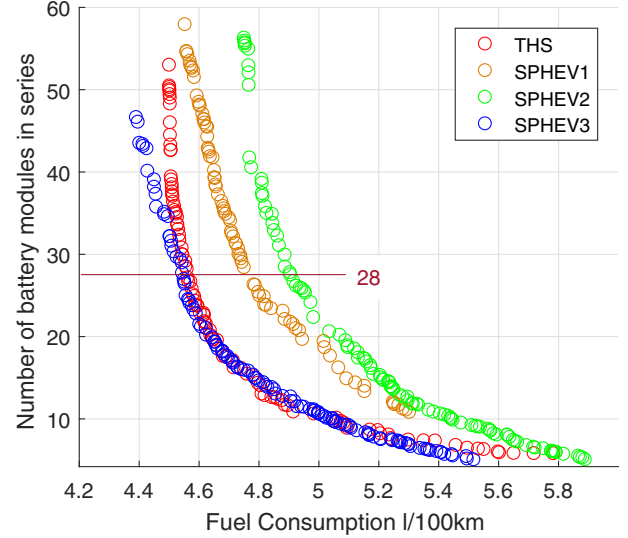

Fig. 6. Pareto front of number of battery modules in series vs. fuel consumption in mixed driving conditions.

TABLE II. POWERTRAINS SIZINGS FOR THE PARETO POINTS OF 28 MODULES IN SERIES

	THS	SPHEV 1	SPHEV 2	SPHEV 3
Power EM1 (KW)	58.0	84.1	68.0	59.3
Power EM2 (KW)	44.6	73.5	55.6	54.3
Power ICE (KW)	47.9	59.9	48.3	52.1
PG	1.5	-	-	-
FD	4.11	4.15	2.2	2.27
G1	-	-	1.94	1.6
G2	-	-	1.28	0.51
G3	-	-	1.40	-
GearBox-1st	-	-	-	2.30
GearBox-2nd	-	-	-	1.06
FC (l/100km)	4.56	4.75	4.90	4.54

- 2) SPHEV 2 has globally a worse fuel consumption than SPHEV 1. The reason behind the gears addition in SPHEV 2 was to try to move the operating points of the system to better efficiency areas, and to allow the parallel mode to be used more often. The effect of this probable improvement seems to be less than the effect of the deterioration in the power paths efficiencies, which results in a higher fuel consumption for the SPHEV 2 powertrain. This result is highly dependent on the gears efficiency.
- 3) SPHEV 3 has comparable fuel consumption to THS. Thanks to the addition of the 2-speed gearbox, the improvements (that can be caused by moving the operating points of the system to better efficiency areas and by the more usage of parallel mode) are now more important than the deterioration in the power paths efficiencies. The end result is a fuel consumption for SPHEV 3 lower than the fuel consumption of SPHEV 1 and comparable to the one of THS.

For a better understanding of the reasons behind the differences in fuel consumption, the Pareto points corresponding to 28 battery modules are considered:

1) *Powertrains sizing*: The sizing of the powertrains for the Pareto point of 28 battery modules is presented in Table II. It is clear that the SPHEV 1 components are oversized compared to the THS. An oversizing is normally associated with series hybrid powertrains, in which the vehicle power demand is not divided between the different traction systems. For SPHEV 2, even if the target of fuel consumption reduction is not reached, a major reduction in the components sizes is achieved. Finally, adding a gearbox in SPHEV 3 results in a more reduction in EM1 size, a minor reduction in EM2 size and a small increase in the size of the ICE.

2) *Powertrains operation in various driving conditions*: The architectures are already optimized for mixed driving conditions. In this subsection, the powertrains corresponding to 28 battery modules are reevaluated in various driving conditions to try to understand the differences present in the Pareto front (Fig. 6).

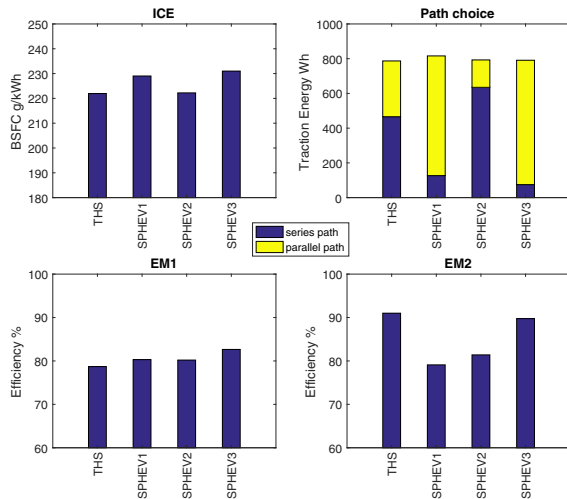

Fig. 7. Powertrains operation in urban conditions

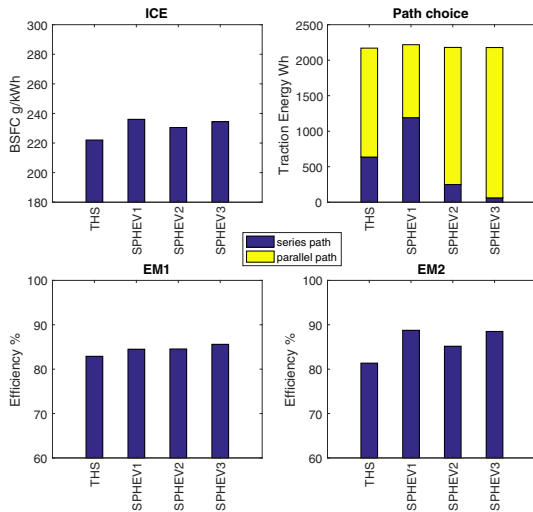

Fig. 8. Powertrains operation in rural road conditions

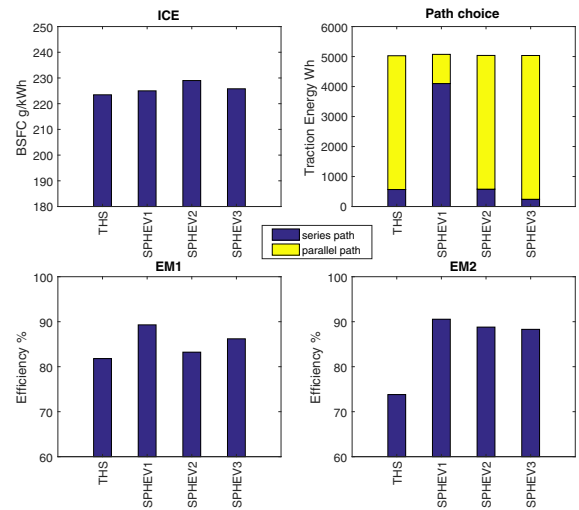

Fig. 9. Powertrains operation in highway conditions

A comparison between the powertrains operation is made for urban (Fig. 7), rural road (Fig. 8) and highway driving conditions (Fig. 9). The average values of the efficiency of the EMs and the specific fuel consumption of the ICE are presented. The shares of the series path in terms of traction energy is also shown. A first possible analysis of the results is proposed hereafter.

a) *THS and SPHEV 1*: THS shows the lowest average engine specific fuel consumption for the 3 considered driving cases. This is due to its added speed DoF provided by the PG. The EM2 efficiency seems to be good in urban conditions but gets deteriorated at high speeds and reaches an average value of 74% in highway conditions. In addition, the traction energy delivered through the series path is dominant in urban conditions(59%) but decreases in rural (29%) and highway conditions (11.2%).

For SPHEV 1, which lacks the speed DoF of THS, operating the engine on its good operating areas is more difficult. This is why the specific fuel consumption of the ICE in SPHEV 1 is higher than in THS. However, the architecture main problem is the major usage of the series path. In fact, even if the final gear ratio is optimized, the simple direct connection between the ICE and EMs causes an impossible permanent matching between the vehicle requirements and the limitations of the 3 components (ICE and EMs) in parallel mode. It is clear that at high speeds the architecture is obliged to deliver most of the traction energy demand through the series path: 54% in rural and 80% in highway. This results in the high fuel consumption and the oversizing of the powertrain (Table II). On the other hand, the speeds of ICE and EM2 in series are independent from the wheels speed. This can explain the improvement in EM2 operation (except in urban).

b) *SPHEV 1 and SPHEV 2*: The addition of gears in SPHEV 2 solves the SPHEV 1 problem of dominance of the series path in rural road and highway conditions, but increases its usage in urban. Nevertheless, the series traction energy decrease in rural and highway is considerably higher than its increase in urban. The combined result is a decrease in the usage of the series mode, which can explain the reduction of

the component sizes in SPHEV 2 (Table II). The improvement in the operation of the components is not clear, except for the ICE in urban and rural. Finally, the increase of the fuel consumption for SPHEV 2 (Fig. 6) is mainly linked to the deterioration of the efficiency of the power paths from the components to the wheels. This is caused by the added mechanical losses in the gears.

c) *SPHEV 3*: SPHEV 3 seems able to solve the problems of the other architectures. It results in the least amount of energy delivered through the series path in all driving conditions. In addition, the EMs are operating in relatively good efficiency areas, and EM2 average efficiency in rural and highway is higher than in the case of THS. The room of improvement for SPHEV3 can be seen in the operation of the ICE in urban and rural conditions. The speed Dof of the PG is still giving the THS an advance over the SPHEV 3 in the engine operation. More enhancements on the SPHEV 3 can be achieved if the number of gear ratios of the gearbox is increased.

IV. CONCLUSION

This paper is part of a global work that is studying the possibility of improvement of the simple series parallel architecture by the addition of gears or gearbox. A first study considering three proposed architectures is presented here. The results already prove that one of them can have comparable fuel consumption to the THS. However, there still exists room for improvement in SPHEV architectures. More variants with different gearbox location and different number of gears should be studied. The understanding of the advantages/drawbacks of gears and gearbox addition that was done in this paper will be guiding the proposition of better topologies in future works. In addition, more investigations will be done in the choice of the electric machines which need to be more adapted to the architectures. Furthermore, the comparison between the architectures in this paper is based on the energy consumption and the size of the battery. Future works will try to include additional aspects of the powertrain (compactness, weight, cost, drivability,...).

REFERENCES

- [1] C. Chan, "The state of the art of electric and hybrid vehicles," *Proceedings of the IEEE*, vol. 90, no. 2, pp. 247–275, 2002.
- [2] E. Vinot, R. Trigui, B. Jeanneret, J. Scordia, and F. Badin, "Hevs comparison and components sizing using dynamic programming," in *Vehicle Power and Propulsion Conference, 2007. VPPC 2007. IEEE*, Sept 2007, pp. 314–321.
- [3] J. M. Miller, *Propulsion systems for hybrid vehicles*. Iet, 2004, vol. 45.
- [4] M. Ehsani, Y. Gao, and J. M. Miller, "Hybrid electric vehicles: architecture and motor drives," *Proceedings of the IEEE*, vol. 95, no. 4, pp. 719–728, 2007.
- [5] R. Trigui, E. Vinot, and B. Jeanneret, "Backward modeling and energy management optimization of a two clutches series-parallel hev for efficiency assessment," in *Power plant and power system control symposium IFAC PPPSC, 2012*, 2012.
- [6] E. Vinot, "Comparison of different power-split architectures using a global optimisation design method," *Int. J Electric and Hybrid Vehicles*, vol. 8, no. 3, pp. 225–241, 2016.
- [7] S. Washino, T. Saito, Y. Jia, H. Okada, R. Savelsberg, and T. Hlshorst, "New 3 mode hybrid system concept," in *24th Aachen Colloquium Automobile and Engine Technology 2015*, 2015, pp. 1123–1140.

- [8] E. Vinot, V. Reinbold, and R. Trigui, "Global optimized design of an electric variable transmission for hevs," *Vehicular Technology, IEEE Transactions on*, vol. 65, no. 8, pp. 6794–6798, 2016.
- [9] V. Reinbold, E. Vinot, L. Garbuio, and L. Gerbaud, "Optimal sizing of an electrical machine using a magnetic circuit model: application to a hybrid electrical vehicle," *IET Electrical Systems in Transportation*, vol. 6, no. 1, pp. 27–33, 2016.
- [10] C. Desai and S. S. Williamson, "Optimal design of a parallel hybrid electric vehicle using multi-objective genetic algorithms," in *Vehicle Power and Propulsion Conference, 2009. VPPC'09. IEEE*. IEEE, 2009, pp. 871–876.
- [11] R. Bellman, *Dynamic Programming*. Princeton University Press, 1957.
- [12] E. Vinot, "Time reduction of the dynamic programming computation in the case of hybrid vehicle," in *Optimization & Inverse Problems in Electromagnetism (OIPE)*, 2014, 2014.
- [13] O. Sundstrom, D. Ambuhl, and L. Guzzella, "On implementation of dynamic programming for optimal control problems with final state constraints," *Oil & Gas Science and Technology—Revue de l'Institut Français du Pétrole*, vol. 65, no. 1, pp. 91–102, 2010.
- [14] Eurostat. Eurostat statistic on population displacement, <http://epp.eurostat.ec.europa.eu/portal/page/portal/transport/data/database>.