



HAL
open science

A Carleman estimate in the neighborhood of a multi-interface and applications to control theory

Rémi Buffe

► **To cite this version:**

Rémi Buffe. A Carleman estimate in the neighborhood of a multi-interface and applications to control theory. 2018. hal-01703306

HAL Id: hal-01703306

<https://hal.science/hal-01703306v1>

Preprint submitted on 7 Feb 2018

HAL is a multi-disciplinary open access archive for the deposit and dissemination of scientific research documents, whether they are published or not. The documents may come from teaching and research institutions in France or abroad, or from public or private research centers.

L'archive ouverte pluridisciplinaire **HAL**, est destinée au dépôt et à la diffusion de documents scientifiques de niveau recherche, publiés ou non, émanant des établissements d'enseignement et de recherche français ou étrangers, des laboratoires publics ou privés.

A Carleman estimate in the neighborhood of a multi-interface and applications to control theory

Rémi Buffe

February 7, 2018

Abstract

We prove a Carleman estimate in a neighborhood of a multi-interface, that is, near a point where n manifolds intersect, under compatibility assumptions between the Carleman weight $e^{\tau\varphi}$, the operators at the multi-interface, and the elliptic operators in the interior and the usual sub-ellipticity condition. The compatibility condition at the multi-interface is a version of the known covering condition for systems in the literature. This Carleman estimate is a generalization of the results obtained in [6, 7]. Applications in control theory for second-order transmission problems are also considered, and provide a generalization of the known results for one-dimensional networks of strings [4, 13, 19, 30] to higher dimensions.

Keywords : Carleman estimate, elliptic operators, multiple interfaces, control, stabilization, Lopatinskiï condition.

AMS 2010 Subject Classification : 35B45, 35G45, 35S15, 35Q93

1 Introduction

We consider n smooth d -dimensional manifolds Ω_k , $d \geq 2$, $i \in \{1, \dots, n\}$ with boundary $\partial\Omega_k$. We assume that they share parts of their boundary. More precisely, we denote by $\partial\Omega_k^i$, $i = 0, \dots, n_k$, the different connected components of $\partial\Omega_k$. We assume that one of these connected components is shared by all manifolds. For instance, we assume that we have

$$\partial\Omega_1^0 = \dots = \partial\Omega_n^0.$$

We set $\Omega = \Omega_1 \cup \dots \cup \Omega_n$, and we call \mathcal{I} the common connected component of their boundaries. Note that Ω is not a manifold because of its topology near \mathcal{I} . We shall refer to \mathcal{I} as an interface between the manifolds. It is itself a $d - 1$ dimensional manifold. An example of such configuration is given in Figure 1. On each Ω_k , we consider an elliptic differential operator P_k of order $2m_k$. In local coordinates (x_1, \dots, x_d) for Ω_k near a point $x^0 \in \mathcal{I}$, where Ω_k is given by $\{x_d \geq 0\}$, the operator P_k reads

$$P_k(x, D) = \sum_{|\alpha| \leq 2m_k} a_\alpha^k(x) D^\alpha,$$

where the coefficients $a_\alpha^k(x)$ are C^∞ complex valued functions, $D_j = -i\partial_{x_j}$ and $D = (D_1, \dots, D_d)$, and $\alpha \in \mathbb{N}^d$ is a multi-index. With their principal symbols given by

$$p_k(x, \xi) = \sum_{|\alpha|=2m_k} a_\alpha^k(x) \xi^\alpha, \quad \xi \in \mathbb{R}^d, x \in \Omega_k, \quad (1.1)$$

the ellipticity assumption reads $|p_k(x, \xi)| \geq C|\xi|^{2m_k}$, with $C > 0$. We set $m = m_1 + \dots + m_n$. For each manifold Ω_k , we also consider a set of boundary operators T_k^ℓ , $\ell = 1, \dots, m$, of order less than or equal to $\beta_k^\ell < 2m_k$, that take the following form in local coordinates

$$T_k^\ell(x, D) = \sum_{|\alpha| \leq \beta_k^\ell} t_{\alpha, k}^\ell(x) D^\alpha, \quad \ell \in \{1, \dots, m\}, k \in \{1, \dots, n\},$$

where the coefficients $t_{\alpha, k}^\ell(x)$ are complex-valued functions defined in a neighborhood of \mathcal{I} in Ω_k . We denote by

$$t_k^\ell(x, \xi) = \sum_{|\alpha| = \beta_k^\ell} t_{\alpha, k}^\ell \xi^\alpha,$$

the principal symbol of the operator T_k^ℓ , for $k \in \{1, \dots, n\}$ and $\ell \in \{1, \dots, m\}$. Note that we may have $t_k^\ell = 0$ if the actual order of T_k^ℓ is less than β_k^ℓ . We assume that the orders satisfy the relations

$$\gamma_\ell := 2m_k - \beta_k^\ell = 2m_j - \beta_j^\ell, \quad \forall k, j \in \{1, \dots, n\}, \ell \in \{1, \dots, m\}. \quad (1.2)$$

We shall consider the following elliptic system, coupled through the interface,

$$\begin{cases} P_k u_k = f_k & \text{in } \Omega_k, \quad k \in \{1, \dots, n\}, \\ \sum_{k=1}^n T_k^\ell(x, D) u_k|_{\mathcal{I}} = g_\ell & \text{on } \mathcal{I}, \quad \ell \in \{1, \dots, m\}. \end{cases} \quad (1.3)$$

The main purpose of this article is the proof of a Carleman estimate for solutions of such system in a neighborhood of a point x^0 of the interface \mathcal{I} .

In [12], Carleman introduced weighted inequalities to prove uniqueness of the Cauchy problem associated with an elliptic operator. The method has been developed later by Hörmander [17]. Carleman estimates for general elliptic operators has been derived away from boundaries in [18]. Recently, for boundaries and interfaces problems, Carleman estimates has been obtained in [6, 7, 29], under Lopatinskii-type assumptions.. The purpose of this article is to generalize these results to systems such as (1.3).

Many Carleman estimates near boundaries and interfaces has been already obtained. For instance, local Carleman estimates near boundaries for Dirichlet [25], Neumann [26], Ventcel [10] conditions has been already obtained by using pseudo-differential methods. Near smooth interfaces, away from boundaries, one can cite for instance [5, 15, 24, 20, 23, 14]. For interfaces that meet the boundary, very few are known. We mention out the works of [8, 9] where the authors obtained a Carleman estimate for medias with a stratified structure. The Carleman estimate we prove, in a neighborhood of a point of the multi-interface \mathcal{I} , has the following form

$$\tau^{-1} \sum_{k=1}^n \|e^{\tau\varphi_k} u_k\| + \sum_{k=1}^n |e^{\tau\varphi}|_{\mathcal{I}} \text{tr } u_k|^2 \leq C \left(\sum_{k=1}^n \|e^{\tau\varphi_k} P_k u_k\| + \sum_{\ell=1}^m \left| \sum_{k=1}^n T_k^\ell u_k|_{\mathcal{I}} \right|^2 \right).$$

where φ_k is a weight function on Ω_k , τ is the usual Carleman large parameter, and $\text{tr } u_k$ denotes the successive normal derivatives of u_k at the multi-interface \mathcal{I} , that is $\text{tr } u_k = (u_k|_{\mathcal{I}}, \partial_\nu u_k|_{\mathcal{I}}, \dots, \partial_\nu^{2m_k-1} u_k|_{\mathcal{I}})$. As usual with Carleman estimates, in the interior, some compatibility conditions between the operators P_k and the weight φ_k are introduced, the so-called *sub-ellipticity* condition (see Section 2.1). At the multi-interface, we also impose some compatibility conditions between the weights φ_k , the boundary operators T_k^ℓ and the interior operators P_k . These conditions are a natural generalization of the well-known Lopatinskii condition (see Section 2.2).

Carleman estimates are a powerful tool to prove control and stabilization properties. In the last section of this article, we provide an application of the Carleman estimate we obtain to a natural transmission

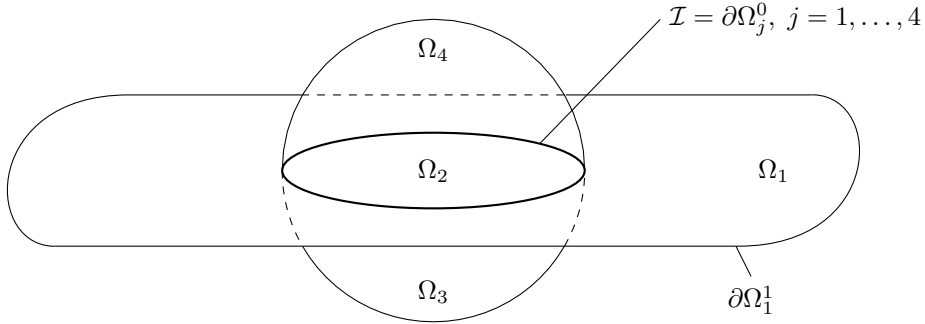

Figure 1: A sphere meets a surface and creates 4 smooth manifolds with boundaries. The shared interface is a connected component of $\partial\Omega_i$, for all $i \in \{1, \dots, n\}$.

problem. Under assumption on the control region, we prove the null-controllability result for the associated parabolic problem, and a stabilization result for the associated hyperbolic one. This generalizes what has been done for one-dimensional networks of strings in [4, 13, 19, 30], and the references therein, to higher dimensions.

This article is organized as follows. In Section 2 we introduce the geometrical setting and the relevant hypothesis on the operators and the weight functions. In Section 3 we prove that we can find proper weight functions for which these conditions are satisfied in the special case of second-order operators with transmission condition through the interface. The general Carleman estimate is proven in Section 4. Finally, we state in Section 5 some of the immediate applications of the Carleman estimate of Theorem 2.6 to null-controllability of heat equation and to logarithmic stabilization of the damped wave equation, provided a natural geometric condition is satisfied (see Section 5.1, and also Section (3.2)).

2 Statement of the problem and geometrical configurations

Let $x^0 \in \mathcal{I}$ be a point of the interface. In each manifold Ω_k , we consider an open bounded neighborhood \tilde{U}_k of x^0 in Ω_k where local coordinates as above can be used. More precisely, for $k = 1, \dots, n$, we use local charts:

$$\phi_k : \Omega_k \supset \tilde{U}_k \longrightarrow V_k^+ = V_k \cap \{x_d \geq 0\}, \quad \phi_k \text{ diffeomorphism, for all } k \in \{1, \dots, n\}, \quad (2.1)$$

with V_k an open set of \mathbb{R}^d , satisfying $\phi_k(x^0) = 0$ and $\phi_k(\mathcal{I} \cap \tilde{U}_k) = \{x_d = 0\} \cap V_k$ for all $k \in \{1, \dots, n\}$. Setting $V = \bigcap_{k=1}^n V_k$ on \mathbb{R}^d and $V^+ = \{x_d \geq 0\} \cap V$, we consider $U_k = \varphi_k^{-1}(V^+)$, and $U = \bigcup_{k=1}^n U_k$ in Ω so that we have

$$\phi_k : \Omega_k \supset U_k \longrightarrow V^+, \quad \phi_k \text{ diffeomorphism, for all } k \in \{1, \dots, n\},$$

and $\phi_k|_{\mathcal{I}} = \phi_\ell|_{\mathcal{I}}$, as sketched in Figure 2.

Throughout this article, two assumptions shall play a central role. The first one is the sub-ellipticity assumption, that is classical when working with Carleman estimates, and the second one is the covering condition (also known as the Shapiro-Lopatinskii condition, or complementing condition).

2.1 The sub-ellipticity condition

For two functions $f(x, \xi)$ and $g(x, \xi)$ in $C^\infty(\mathbb{R}^d \times \mathbb{R}^d)$, we recall that their Poisson bracket is given by

$$\{f, g\}(x, \xi) = \partial_\xi f(x, \xi) \partial_x g(x, \xi) - \partial_x f(x, \xi) \partial_\xi g(x, \xi).$$

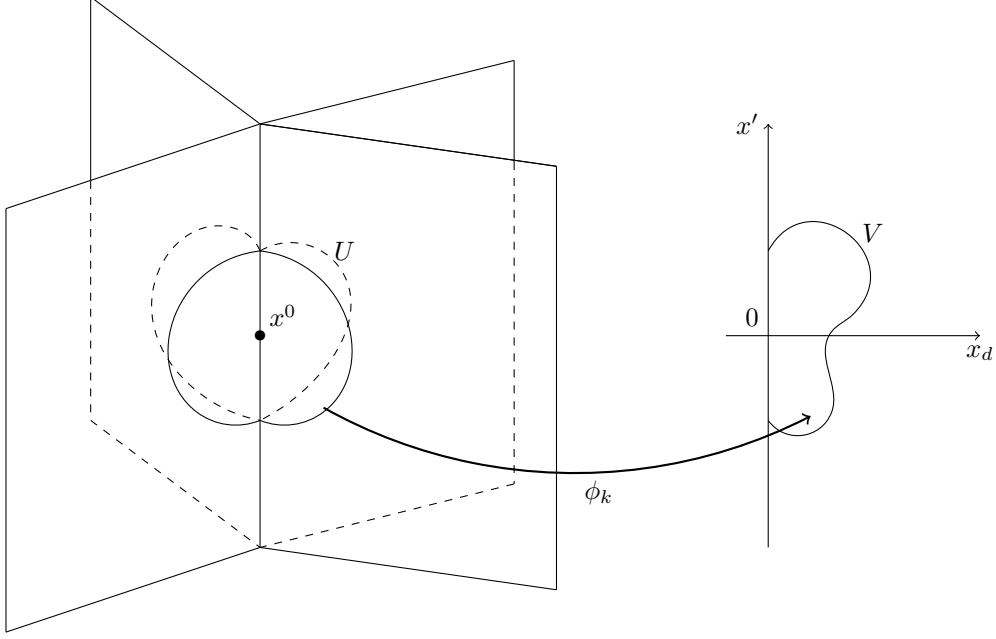

Figure 2: Local configuration and local charts in the neighborhood of the interface.

From symbolic calculus, $\{f, g\}$ is the principal symbol of the commutator $i[\text{Op}(f), \text{Op}(g)]$. For $k \in \{1, \dots, n\}$, we let φ_k be a real C^∞ function on $\bar{\Omega}_k$, and we consider the conjugated operators

$$P_{k, \varphi_k} = e^{\tau \varphi_k} P_k e^{-\tau \varphi_k}, \quad (2.2)$$

with principal symbol $p_{k, \varphi}(x, \xi, \tau) = p_k(x, \xi + i\tau d\varphi_k(x))$ in a semi-classical sense. In general, P_{k, φ_k} is not elliptic. The sub-ellipticity condition states that $[P_{k, \varphi_k}^*, P_{k, \varphi_k}]$ is elliptic positive where P_{k, φ_k} fails to be elliptic. More precisely, we write the following definition.

Definition 2.1. Let $k \in \{1, \dots, n\}$. We say that (P_k, φ_k) satisfies the sub-ellipticity condition on \bar{U}_k if $d\varphi_k \neq 0$ on \bar{U}_k and if

$$p_{k, \varphi}(x, \xi, \tau) = 0 \implies \left\{ \text{Re } p_{k, \varphi}, \text{Im } p_{k, \varphi} \right\}(x, \xi, \tau) = \frac{1}{2i} \left\{ \bar{p}_{k, \varphi}, p_{k, \varphi} \right\}(x, \xi, \tau) > 0, \quad (2.3)$$

for all $x \in \bar{U}_k, \tau > 0$, and all $\xi \in \mathbb{R}^d, \xi \neq 0$.

For the case of elliptic operators of order two, it is well-known that the following lemma gives a construction of such a weight function.

Lemma 2.2. Let U be an open subset of \mathbb{R}^d , M be an elliptic operator of order two, and ψ be a smooth function on \bar{U} such that $\nabla \psi \neq 0$ on \bar{U} . We set $\varphi_\lambda = e^{\lambda \psi}$, for $\lambda > 0$. Then, there exists $\lambda_0 > 0$ such that (M, φ_λ) satisfies the sub-ellipticity condition of Definition 2.1, for all $\lambda \geq \lambda_0$.

The proof of this lemma can be found for instance in [16]. Note that there exist operators such that the sub-ellipticity condition cannot be achieved, independently of the choice of φ . This is for instance the case for the Bi-Laplace operator. Indeed, in this case, we have $p_{k, \varphi} = q_{k, \varphi}^2$, where q_k is the principal symbol of the Laplace operator. The Poisson bracket is then given by

$$\frac{1}{2i} \left\{ \bar{p}_{k, \varphi}, p_{k, \varphi} \right\} = \frac{1}{2i} \left(\partial_\xi \bar{p}_{k, \varphi} \partial_x p_{k, \varphi} - \partial_x \bar{p}_{k, \varphi} \partial_\xi p_{k, \varphi} \right) = \frac{2|q_{k, \varphi}|^2}{i} \left(\partial_\xi \bar{q}_{k, \varphi} \partial_x q_{k, \varphi} - \partial_x \bar{q}_{k, \varphi} \partial_\xi q_{k, \varphi} \right),$$

and we see that this cannot be positive on the characteristic set of $p_{k,\varphi}$.

In addition to the sub-ellipticity condition of the couples (P_k, φ_k) , when considering systems as (1.3) with general operators and boundary conditions, we have to impose some compatibility properties between the operators in the interior and at the boundary, even for well-posedness properties. For Carleman estimates, this is also the case, for the conjugated operator.

2.2 The covering condition

For $x \in \mathcal{I}$, we shall denote by $T_x(\mathcal{I})$ and $T_x^*(\mathcal{I})$ respectively the tangent and cotangent spaces to \mathcal{I} above x , and $T^*(\mathcal{I}) = \{(x, \nu), x \in \mathcal{I}, \nu \in T_x^*(\mathcal{I})\}$. We moreover define the conormal spaces, for $x \in \mathcal{I}$,

$$N_{x,k}^*(\mathcal{I}) = \{\nu \in T_x^*(\Omega_k), \nu(Y) = 0, \forall Y \in T_x(\mathcal{I})\},$$

and

$$N_k^*(\mathcal{I}) = \{(x, \nu), x \in \mathcal{I}, \nu \in N_{x,k}^*(\mathcal{I})\}.$$

For all $k \in \{1, \dots, n\}$, we define a boundary quadruple $\rho_k = (x, Y, \nu_k, \tau)$, where

$$x \in \mathcal{I} \cap \bar{U}, Y \in T_x^*(\mathcal{I}), \nu_k \in N_{x,k}^*(\mathcal{I}), \text{ and } \tau > 0. \quad (2.4)$$

Moreover, we impose ν_k to be an inward pointing conormal vector, that is, $\nu = (0, \dots, 0, t)$ with $t > 0$ in the local chart (U_k, ϕ_k) given in (2.1). We shall denote by $\mathcal{L}_k^{*,+}(\mathcal{I})$ the set of such ρ_k . We define for a fixed $x \in \mathcal{I}$,

$$\mathcal{L}_x^*(\mathcal{I}) := \{(x, Y, \nu_1, \dots, \nu_n, \tau), \forall k \in \{1, \dots, n\}, \rho_k = (x, Y, \nu_k, \tau) \in \mathcal{L}_k^{*,+}(\mathcal{I})\}, \quad (2.5)$$

and we also consider

$$\mathcal{L}^*(\mathcal{I}) := \{(x, Y, \nu_1, \dots, \nu_n, \tau), (Y, \nu_1, \dots, \nu_n, \tau) \in \mathcal{L}_x^*(\mathcal{I}), x \in \mathcal{I}\}. \quad (2.6)$$

We introduce a weight function φ defined on U , which is smooth in each Ω_k and continuous across the interface \mathcal{I} . We shall denote $\varphi_k = \varphi|_{\Omega_k}$. For $\rho_k \in \mathcal{L}_k^{*,+}(\mathcal{I})$ we introduce, for all $\lambda \in \mathbb{C}$,

$$\tilde{p}_{k,\varphi}(\rho_k, \lambda) = p_k(x, Y + \lambda\nu_k + i\tau d\varphi_k(x)).$$

Considering the following factorization, as a polynomial in $\lambda \in \mathbb{C}$,

$$\tilde{p}_{k,\varphi}(\rho_k, \lambda) = c_k \tilde{p}_{k,\varphi}^-(\rho_k, \lambda) \tilde{p}_{k,\varphi}^0(\rho_k, \lambda) \tilde{p}_{k,\varphi}^+(\rho_k, \lambda), \quad (2.7)$$

with $\tilde{p}_{k,\varphi}^0(\rho_k, \lambda) = \prod_{\text{Im } \sigma_k^j(\rho_k)=0} (\lambda - \sigma_k^j(\rho_k))^{\mu_k^j}$ and $\tilde{p}_{k,\varphi}^\pm(\rho_k, \lambda) = \prod_{\pm \text{Im } \sigma_k^j(\rho_k) > 0} (\lambda - \sigma_k^j(\rho_k))^{\mu_k^j}$, where $(\sigma_k^j)_j$ are the complex roots of $\tilde{p}_{k,\varphi}$ as a polynomial in λ , with multiplicity μ_k^j . It should be kept in mind that this factorization depends heavily on the choice of ρ_k . We set

$$\tilde{\kappa}_{k,\varphi}(\rho_k, \lambda) := \tilde{p}_{k,\varphi}^+(\rho_k, \lambda) \tilde{p}_{k,\varphi}^0(\rho_k, \lambda).$$

We also define at the boundary, for all λ ,

$$t_{k,\varphi}^\ell(\rho_k, \lambda) = t_k^\ell(x, Y + \lambda\nu_k + i\tau d\varphi_k(x)).$$

Definition 2.3. We say that $(T_k^\ell, \varphi)_{k \in \{1, \dots, n\}, \ell \in \{1, \dots, m\}}$ covers $(P_k, \varphi)_{k \in \{1, \dots, n\}}$ at $\rho^0 \in \mathcal{L}^*(\mathcal{I})$ if for all polynomials $f_k \in \mathbb{C}[\lambda]$ there exists $c_1, \dots, c_m \in \mathbb{C}$ and polynomials $q_k \in \mathbb{C}[\lambda]$ such that, for all $k \in \{1, \dots, n\}$,

$$f_k(\lambda) = \sum_{\ell=1}^m c_\ell t_{k,\varphi}^\ell(\rho_k^0, \lambda) + q_k(\lambda) \kappa_{k,\varphi}(\rho_k^0, \lambda).$$

We shall say that $(T_k^\ell, \varphi)_{k,\ell}$ covers $(P_k, \varphi)_k$ at x if this holds for all $\rho^0 \in \mathcal{L}_x^*(\mathcal{I})$, and we shall say that $(T_k^\ell, \varphi)_{k,\ell}$ covers $(P_k, \varphi)_k$ if this holds for all $\rho^0 \in \mathcal{L}^*(\mathcal{I})$

Observe that in the above definition, we can restrict the degree of the polynomials f_k to be less than or equal to $2m_k - 1$, using the Euclidean division. If we write $m_k^+ = d^\circ \kappa_{k,\varphi}$ and $m_k^- = 2m_k - m_k^+$, then $d^\circ q_k$ is at most equal to $2m_k - m_k^+ - 1 = m_k^- - 1$. We can reformulate the above definition as follows. Introducing, for $k \in \{1, \dots, n\}$

$$e_k^\ell(\rho_k^0, \lambda) = \begin{cases} t_{k,\varphi}^\ell(\rho_k^0, \lambda) & \text{if } \ell \in \{1, \dots, m\} \\ \lambda^{\ell-(m+1)} \kappa_{k,\varphi}(\rho_k^0, \lambda) & \text{if } \ell \in \{m+1, \dots, m+m_k^-\}, \end{cases} \quad (2.8)$$

and the linear map

$$\begin{aligned} \Phi : \mathbb{C}^m \times \mathbb{C}^{m_1^-} \times \dots \times \mathbb{C}^{m_n^-} &\rightarrow \mathbb{C}_{2m_1-1}[\lambda] \times \dots \times \mathbb{C}_{2m_n-1}[\lambda] \\ \left(\begin{pmatrix} c_1 \\ \vdots \\ c_m \end{pmatrix}, \begin{pmatrix} q_{1,1} \\ \vdots \\ q_{1,m_1^-} \end{pmatrix}, \dots, \begin{pmatrix} q_{n,1} \\ \vdots \\ q_{n,m_n^-} \end{pmatrix} \right) &\mapsto \left(\sum_{\ell=1}^m c_\ell e_1^\ell + \sum_{\ell=m+1}^{m+m_1^-} q_{1,\ell-m} e_1^\ell, \dots, \sum_{\ell=1}^m c_\ell e_n^\ell + \sum_{\ell=m+1}^{m+m_n^-} q_{n,\ell-m} e_n^\ell \right), \end{aligned}$$

Definition 2.3 is precisely equivalent to the surjectivity of the above map Φ .

Remark 2.4. Like the sub-ellipticity condition, the covering condition is unvariant under a change of coordinates. In particular, this definition does not depend on the sizes of the conormal vectors ν_k .

2.3 On the well-posedness of systems satisfying the covering condition

The well-posedness of elliptic systems satisfying the covering condition is a known fact for a non-conjugated system (that is, in the case $\tau\varphi = 0$). We refer for instance to [1, 2]. In their setting, they consider a more general system. It can be related to our problem as explained as follows. Near a point of \mathcal{I} , we can choose a coordinates system for each Ω_k and thus the problem can be reformulated in \mathbb{R}_+^d , as in Section 2. This choice of coordinates has no impact on the covering condition as it is invariant under a change of coordinates. In [1, 2], the authors consider systems of mixed-order elliptic operators in the half-space, that are said to be properly elliptic, i.e the roots σ_i of $\det(A(x, \Theta_1 + z\Theta_2))$, viewed as a polynomial in $z \in \mathbb{C}$ satisfies

$$\#\{\text{Im}(\sigma_i) > 0\} = \#\{\text{Im} \sigma_i < 0\}, \quad \text{for } \Theta_1, \Theta_2 \in \mathbb{R}^d, \text{ linearly independent.}$$

In our case, the considered matrix A is diagonal, thus the determinant is the product of the symbols $p_k(x, \Theta_1 + z\Theta_2)$. If the system is properly elliptic, we obtain that $m = m_1^+ + \dots + m_n^+ = m_1^- + \dots + m_n^-$. Hence,

$$\dim(\mathbb{C}^m \times \mathbb{C}^{m_1^-} \times \dots \times \mathbb{C}^{m_n^-}) = \dim(\mathbb{C}_{2m_1-1}[\lambda] \times \dots \times \mathbb{C}_{2m_n-1}[\lambda]),$$

and then Φ is onto if and only if Φ is one-to-one. The covering condition stated in [1, 2] precisely implies that the map Φ is one-to-one, and the covering condition in the present work implies that the map Φ is onto. Thus, in the setting of properly elliptic diagonal system of operators, those two conditions are consistent. However, in the present article, we ask for the *conjugated* operator to satisfy the covering condition, and moreover, as we shall see, the conjugated system may not be elliptic anymore. We give the following definition.

Definition 2.5. Let (T_k^ℓ, P_k) be a system of operators such as (1.3) satisfying

$$(T_k^\ell, 0)_{k,\ell} \text{ covers } (P_k, 0)_k. \quad (2.9)$$

We say that the weight function φ preserves the covering condition for (T_k^ℓ, P_k) if we also have

$$(T_k^\ell, \varphi)_{k,\ell} \text{ covers } (P_k, \varphi)_k.$$

An interesting question then arises: given a system (T_k^ℓ, P_k) that satisfies (2.9), can we always find a weight function that preserve the covering condition for (T_k^ℓ, P_k) ? We give a positive answer for the special case of transmission conditions for Laplace-Beltrami operators in Section 3.

2.4 Statement of the main result

The main result of this article is the following Carleman estimate in the neighborhood of the interface. We define the following space of smooth functions defined in a neighborhood of the point of interest at the interface.

$$\overline{C}_0^\infty(U_k) = \{w \in C^\infty(\Omega_k), \text{supp}(w) \subset U_k \text{ is compact in } \Omega_k\}. \quad (2.10)$$

Theorem 2.6. *Let $x_0 \in \mathcal{I}$ and let φ be a weight function on U such that $\varphi \in C^0(U)$ and such that $\varphi|_{U_k} \in C^\infty(U_k)$. In addition, assume that (P_k, φ_k) satisfies the sub-ellipticity condition of Definition 2.1 in a neighborhood of x_0 in Ω_k , for all $k \in \{1, \dots, n\}$, and assume that $(T_k^\ell, \varphi)_{k \in \{1, \dots, n\}, \ell \in \{1, \dots, m\}}$ covers $(P_k, \varphi)_{k \in \{1, \dots, n\}}$ at $x_0 \in \mathcal{I}$ (see Definition 2.3). Then, there exists a neighborhood \tilde{U} of x_0 in Ω , $C > 0$, and $\tau_0 > 0$ such that*

$$\begin{aligned} \tau^{-1} \sum_{k=1}^n \|e^{\tau\varphi_k} u_k\|_{2m_k, \tau}^2 + \sum_{k=1}^n |e^{\tau\varphi|_{\mathcal{I}}} \text{tr} u_k|_{2m_k-1, 1/2, \tau}^2 \\ \leq C \left(\sum_{k=1}^n \|e^{\tau\varphi_k} P_k u_k\|_{L^2(\Omega_k)}^2 + \sum_{\ell=1}^m \left| \sum_{k=1}^n T_k^\ell u_k|_{\mathcal{I}} \right|_{\gamma^{\ell-1/2, \tau}}^2 \right), \end{aligned} \quad (2.11)$$

for all $\tau \geq \tau_0$, for all $u \in C_0^\infty(\tilde{U})$ such that $u_k := u|_{U_k \cap \tilde{U}} \in \overline{C}_0^\infty(U_k \cap \tilde{U})$.

This Carleman estimate is local in a neighborhood of a point of the interface. Local Carleman estimates can be generally patched together to obtain a global one. For such issue, we refer to Section 5.1. The various norms are presented in Section 4.1.3. Let us simply mention that

1. $\|\cdot\|_{s, \tau}$ is equivalent to $\tau^s \|\cdot\|_{L^2} + \|\cdot\|_{H^s}$ in some Ω_k ;
2. $|\cdot|_{s, \tau}$ is equivalent to $\tau^s |\cdot|_{L^2(\mathcal{I})} + |\cdot|_{H^s(\mathcal{I})}$. Norms on the interface are denoted by $|\cdot|$ for easier reading;
3. on \mathcal{I} , for $r \in \mathbb{N}$ and $s \in \mathbb{R}$, we mean

$$|\text{tr} w|_{r, s, \tau} = \sum_{\ell=0}^r |\partial_\nu^\ell w|_{r+s-\ell, \tau},$$

using the notation of 2).

2.5 Conditions in a neighborhood of the interface

Let $x_0 \in \mathcal{I}$. We use the local chart introduce in (2.1) and the neighborhood $V^+ = \{x_d \geq 0\} \cap V$ in \mathbb{R}^d . We shall often use the notation $x = (x', x_d)$ and $\xi = (\xi', \xi_d)$. We also introduce

$$\overline{C}_0^\infty(V^+) = \{u|_{\overline{V^+}}, u \in C_0^\infty(V)\}, \quad (2.12)$$

the set of restrictions to V^+ of smooth and compactly supported functions in V . Note that Definition (2.12) is consistent with (2.10).

In this coordinate system, the operators P_k reads

$$P_k = \sum_{|\alpha| \leq 2m_k} a_\alpha^k(x) D^\alpha, \quad k = 1, \dots, n,$$

for x in V^+ , and near the boundary $V \cap \{x_d = 0\}$, the boundary operators read

$$T_k^\ell = \sum_{|\alpha| \leq \beta_k^\ell} t_{\alpha_k}^\ell D^\alpha, \quad k = 1, \dots, n, \ell = 1, \dots, m,$$

with $\beta_k^\ell \in \{1, \dots, 2m_k - 1\}$ and $m = m_1 + \dots + m_n$. We call $p_k(x, \xi)$ and $t_k^\ell(x, \xi)$ their principal symbols. We also introduce the symbols

$$p_{k,\varphi}(x, \xi, \tau) = p_k(x, \xi + i\tau d\varphi_k), \quad t_{k,\varphi}^\ell(x, \xi, \tau) = t_k^\ell(x, \xi + i\tau d\varphi_k),$$

which are respectively the principal symbols of the conjugated operators $P_{k,\varphi} := e^{\tau\varphi_k} P_k e^{-\tau\varphi_k}$ and $T_{k,\varphi}^\ell := e^{\tau\varphi_k} T_k^\ell e^{-\tau\varphi_k}$. In this coordinate system, we make the following identification

$$\mathcal{L}_k^{*,+}(\mathcal{I}) \cong \{\rho = (x, \xi, \tau) \in (\{x_d = 0\} \cap \bar{V}) \times \mathbb{R}_+^d \times \mathbb{R}^+\}.$$

We furthermore allow one to identify all the $\mathcal{L}_k^{*,+}(\mathcal{I})$ to one another. Moreover, as Definition 2.3 is coordinate invariant (see Remark 2.4) we can identify $\mathcal{L}^*(\mathcal{I})$ with $\mathcal{L}_k^{*,+}(\mathcal{I})$ for all $k \in \{1, \dots, n\}$. We also set the cotangent bundle over \mathcal{I} with parameter τ as

$$\mathcal{L}^T(\mathcal{I}) \cong \{\rho' = (x, \xi', \tau) \in (\{x_d = 0\} \cap \bar{V}) \times \mathbb{R}^{d-1} \times \mathbb{R}^+\}.$$

For $\rho' \in \bar{V}^+ \times \mathbb{R}^{d-1} \times \mathbb{R}^+$, we consider the complex roots $\sigma_{k,1}(\rho'), \dots, \sigma_{k,\ell_k}(\rho')$ of multiplicity $\mu_{k,j}$ (satisfying $\mu_{k,1} + \dots + \mu_{k,\ell_k} = 2m_k$) of the symbol $p_{k,\varphi}(\rho', \xi_d)$, viewed as a polynomial in ξ_d . Let $\rho'_0 \in \bar{V}^+ \times \mathbb{R}^{d-1} \times \mathbb{R}^+$ be fixed in what follows. From Lemma A.2 in [Bellassoued- Le Rousseau], there exists a conic neighborhood \mathcal{V} of ρ'_0 in $\bar{V}^+ \times \mathbb{R}^d \times \mathbb{R}^+$ and three smooth and homogeneous polynomials $p_k^\pm(\rho', \xi_d)$, $p_k^0(\rho', \xi_d)$ in ξ_d , such that

1. each polynomial is of constant degree for $\rho' \in \mathcal{V}$;
2. we have the following factorization

$$p_{k,\varphi}(\rho', \xi_d) = a(\rho') p_{k,\varphi}^+(\rho', \xi_d) p_{k,\varphi}^-(\rho', \xi_d) p_{k,\varphi}^0(\rho', \xi_d), \quad \rho' \in \mathcal{V}, \quad (2.13)$$

where $a(\rho')$ is the leading coefficient;

3. the roots of $p_{k,\varphi}^+(\rho', \xi_d)$ and $p_{k,\varphi}^-(\rho', \xi_d)$ have positive and negative imaginary parts respectively for all $\rho' \in \mathcal{V}$;
4. at $\rho' = \rho'_0$ we have

$$p_{k,\varphi}^\pm(\rho'_0, \xi_d) = \prod_{\pm \operatorname{Im} \sigma_{k,j}(\rho'_0) > 0} (\xi_d - \sigma_{k,j}(\rho'_0))^{\mu_{k,j}}, \quad p_{k,\varphi}^0(\rho'_0, \xi_d) = \prod_{\operatorname{Im} \sigma_{k,j}(\rho'_0) = 0} (\xi_d - \sigma_{k,j}(\rho'_0))^{\mu_{k,j}}.$$

Note that the decomposition thus depends on ρ'_0 . Note also that for $\rho' \in \mathcal{V}$, the sign of the imaginary part of the roots of $p_{k,\varphi}^0(\rho', \xi_d)$ is not prescribed. However, at $\rho' = \rho'_0$ those imaginary parts vanish.

We set $\kappa_{k,\varphi}(\rho', \xi_d) = p_{k,\varphi}^+(\rho', \xi_d) p_{k,\varphi}^-(\rho', \xi_d)$. In fact, while the roots $\sigma_{k,j}(\rho')$ are only continuous, since they can cross each other, we shall work with the polynomials given in (2.13); they are smooth, which permits the use of semi-classical calculus. We can reformulate the covering condition at ρ'_0 as follows: for all family of polynomials $(f_k)_{k \in \{1, \dots, n\}} \in \mathbb{C}[\xi_d]^n$, there exists $(c_1, \dots, c_m) \in \mathbb{C}^m$ and a family of polynomials $(q_k)_{k \in \{1, \dots, n\}} \in \mathbb{C}[\xi_d]^n$ such that

$$f_k(\xi_d) = \sum_{\ell=1}^m c_\ell t_{k,\varphi}^\ell(\rho'_0, \xi_d) + q_k(\xi_d) \kappa_{k,\varphi}(\rho'_0, \xi_d), \quad \forall k \in \{1, \dots, n\}.$$

In this setting, the covering condition can also be stated in a more convenient way, such as follows. Setting $m_k^- = d^\circ p_{k,\varphi}^-$, we write

$$\kappa_{k,\varphi}(\rho', \xi_d) = \sum_{i=0}^{2m_k - m_k^-} \kappa_{k,\varphi}^i(\rho') \xi_d^i$$

where $\kappa_{k,\varphi}^i$ is homogeneous of degree $2m_k - m_k^- - i$ in (ξ', τ) . Similarly, we write

$$t_{k,\varphi}^\ell(\rho', \xi_d) = \sum_{i=0}^{\beta_k^\ell} t_{k,\varphi}^{\ell,i}(\rho') \xi_d^i, \quad (2.14)$$

where $t_{k,\varphi}^{\ell,i}$ is homogeneous of degree $\beta_k^\ell - i$ in (ξ', τ) . Arguing as in (2.8), we introduce

$$e_k^\ell(\rho', \xi_d) = \begin{cases} t_{k,\varphi}^\ell(\rho', \xi_d) & \text{if } \ell \in \{1, \dots, m\} \\ \xi_d^{\ell-(m+1)} \kappa_{k,\varphi}(\rho', \xi_d) & \text{if } \ell \in \{m+1, \dots, m+m_k^-\}, \end{cases} \quad (2.15)$$

and the covering condition is equivalent to the surjectivity at $\rho' = \rho_0$ of the map

$$\begin{aligned} \Phi : \mathbb{C}^m \times \mathbb{C}^{m_1^-} \times \dots \times \mathbb{C}^{m_n^-} &\longrightarrow \mathbb{C}_{2m_1-1}[\xi_d] \times \dots \times \mathbb{C}_{2m_n-1}[\xi_d] \\ \left(\begin{pmatrix} c_1 \\ \vdots \\ c_m \end{pmatrix}, \begin{pmatrix} q_{1,1} \\ \vdots \\ q_{1,m_1^-} \end{pmatrix}, \dots, \begin{pmatrix} q_{n,1} \\ \vdots \\ q_{n,m_n^-} \end{pmatrix} \right) &\longmapsto \left(\sum_{\ell=1}^m c_\ell e_1^\ell + \sum_{\ell=m+1}^{m+m_1^-} q_{1,\ell-m} e_1^\ell, \dots, \sum_{\ell=1}^m c_\ell e_n^\ell + \sum_{\ell=m+1}^{m+m_n^-} q_{n,\ell-m} e_n^\ell \right). \end{aligned}$$

If we write $e_k^\ell(\rho', \xi_d) = \sum_{i=0}^{2m-1} e_{k,\varphi}^{\ell,i}(\rho') \xi_d^i$, the coefficients $e_{k,\varphi}^{\ell,i}$ (that are homogeneous in (ξ', τ)) are given by

- if $\ell \in \{1, \dots, m\}$, $e_{k,\varphi}^{\ell,i}(\rho') = \begin{cases} t_{k,\varphi}^{\ell,i}(\rho') & \text{if } i \in \{0, \dots, \beta_k^\ell\} \\ 0 & \text{otherwise,} \end{cases}$
- if $\ell \in \{m+1, \dots, m+m_k^-\}$, $e_{k,\varphi}^{\ell,i}(\rho') = \begin{cases} \kappa_{k,\varphi}^{i-\ell+m+1}(\rho') & \text{if } i \in \ell - (m+1) + \{0, \dots, 2m_k - m_k^-\} \\ 0 & \text{otherwise.} \end{cases}$

if $m_k^- > 0$. Then, for $k \in \{1, \dots, n\}$, we set the $2m_k \times m$ matrix

$$M_k^1(\rho') = \left(e_{k,\varphi}^{\ell,i-1}(\rho') \right)_{(i,\ell) \in \{1, \dots, 2m_k\} \times \{1, \dots, m\}}.$$

If moreover $m_k^- > 0$, we set the $2m_k \times m_k^-$ matrix

$$M_k^2(\rho') = \left(e_{k,\varphi}^{m+\ell,i-1}(\rho') \right)_{(i,\ell) \in \{1, \dots, 2m_k\} \times \{1, \dots, m_k^-\}}.$$

With M_k^2 and M_k^1 , we define the $2m \times (m + m_1^- + \dots + m_n^-)$ matrix

$$M(\rho') = \begin{pmatrix} M_1^1(\rho') & M_1^2(\rho') & 0 & \dots & 0 \\ M_2^1(\rho') & 0 & M_2^2(\rho') & \dots & 0 \\ \vdots & \vdots & 0 & \ddots & 0 \\ M_n^1(\rho') & 0 & \dots & \dots & M_n^2(\rho') \end{pmatrix}, \quad (2.16)$$

where the column associated with $M_k^2(\rho')$ only occurs if $m_k^- > 0$. For convenience, we shall say that $M_k^2(\rho') = \emptyset$ if $m_k^- = 0$. With this matrix, the covering condition at $\rho' = \rho_0$ is equivalent to

$$\text{Rank } M(\rho_0) = 2m. \quad (2.17)$$

Remark 2.7. Considering the size of $M(\rho')$, a necessary condition for the covering condition to hold is $m + m_1^- + \dots + m_n^- \geq 2m$.

Lemma 2.8. *If the covering condition is satisfied in a point $\rho'_0 \in \mathcal{L}^T(\mathcal{I})$, then there exists a conic neighborhood \mathcal{V} of ρ'_0 in $\mathcal{L}^T(\mathcal{I})$ such that the rank condition (2.17) is fulfilled for every $\rho' \in \mathcal{V}$.*

Proof. If $\text{Rank } M(\rho'_0) \geq 2m$, then there exists a $2m \times 2m$ submatrix $S(\rho'_0)$ such that $\det S(\rho'_0) \neq 0$. As the symbols of M_k^1 and of M_k^2 are continuous and homogeneous in (ξ', τ) of order $\beta_k^j - (i+1)$ and $2m_k - m_k^- + j - i - 1 - m$ respectively, where i and j index the rows and the columns. As a result, $\det S(\rho_0)$ is also continuous and homogeneous in (ξ', τ) . We restrict ourselves to the compact set $\rho' \in \mathcal{L}^T(\mathcal{I}) \cap \mathbb{S}_{(\xi', \tau)=1}$. By continuity, there exists a neighborhood \mathcal{V}_0 of ρ'_0 in $\mathcal{L}^T(\mathcal{I}) \cap \mathbb{S}_{(\xi', \tau)=1}$ such that $\det S(\rho') \neq 0$ for all $\rho' \in \mathcal{V}_0$. The result follows by homogeneity. \square

Remark 2.9. *Note that we proved that if the covering condition is satisfied in some point $\rho'_0 \in \mathcal{L}^T(\mathcal{I})$ then there exists a conic neighborhood \mathcal{V} of ρ'_0 such that (2.17) holds, but we did not prove that the covering condition is satisfied for any $\rho' \in \mathcal{V}$. In what follows, we shall only need Lemma 2.8.*

3 The case of second-order operators

3.1 The transmission problem

Here, we address the important case of second-order elliptic operators with real principal symbol, for $k = 1, \dots, n$, namely Laplace-Beltrami operators associated with some metrics g_k on each manifold. We consider the following transmission problem

$$\begin{cases} A_k u_k = 0, & k = 1, \dots, n & \text{in the interior of } \Omega_k \\ u_1|_{\mathcal{I}_1} = \dots = u_n|_{\mathcal{I}_n} & & \text{on } \mathcal{I} \\ \sum_{k=1}^n \partial_{\nu_k} u_k|_{\mathcal{I}} = 0 & & \text{on } \mathcal{I}, \end{cases} \quad (3.1)$$

where $A_k = -\Delta_{g_k} + \text{lower order terms}$, where (Ω_k, g_k) are Riemannian manifolds with boundary \mathcal{I}_k satisfying $\mathcal{I} := \mathcal{I}_1 = \dots = \mathcal{I}_n$, where Δ_{g_k} is the Laplace-Beltrami operator associated with the metric g_k , and ν_k denotes the unit outward pointing normal vector of \mathcal{I}_k with respect to the metric g_k . Following Section 2, in $\Omega = \cup_{k=1}^n \Omega_k$, in a neighborhood of a point $y \in \mathcal{I}$ we can use coordinates $x' = (x_1, \dots, x_{d-1})$ on \mathcal{I} and coordinates $x = (x', x_d)$ on Ω_k such that locally $\mathcal{I} = \{x_d = 0\}$ and $\Omega_k = \{x_d \geq 0\}$. In this set of coordinates, System (3.1) reads

$$\begin{cases} P_k(x, D)u_k = 0, & k = 1, \dots, n & \text{in } \Omega_k \cap \{x_d > 0\} \\ u_1|_{\mathcal{I}} = \dots = u_n|_{\mathcal{I}} & & \text{on } \mathcal{I} \\ \sum_{k=1}^n \partial_{\nu_k} u_k|_{\mathcal{I}} = 0 & & \text{on } \mathcal{I}, \end{cases} \quad (3.2)$$

where the principal part of $P_k(x, D)$ is of the form $\sum_{1 \leq i, j \leq d} D_i a_{i,j}^k D_j$, where $a_{i,j}^k$ are coefficients dependent on the metric g_k . These transmission conditions can be rewritten as the following equations

$$u_1|_{\mathcal{I}} - u_2|_{\mathcal{I}} = 0, \quad u_2|_{\mathcal{I}} - u_3|_{\mathcal{I}} = 0, \quad \dots, \quad u_{n-1}|_{\mathcal{I}} - u_n|_{\mathcal{I}} = 0, \quad \sum_{k=1}^n \sum_{j=1}^d a_{d,j}^k(x) \partial_{x_j} u_k|_{\mathcal{I}} = 0.$$

Here $m = n$. With the notation of System (1.3), we consider the following set of operators

$$\begin{cases} T_k^\ell &= \delta_{k,\ell} - \delta_{k,\ell+1}, & k \in \{1, \dots, n\}, \ell \in \{1, \dots, n-1\}, \\ T_k^n &= \sum_{j=1}^d a_{d,j}^k(x) D_j, & k \in \{1, \dots, n\}. \end{cases} \quad (3.3)$$

This type of transmission condition across an interface has a natural physical meaning. It simply implies continuity of the solution at \mathcal{I} and that the fluxes add up to zero. We shall conjugate the operators with

a function φ , which is chosen smooth in each \mathcal{I} , and only continuous across the interface. We shall denote $\varphi|_{\Omega_k} = \varphi_k$. In this example, the principal symbols of the conjugated operators at the boundary read

$$t_{k,\varphi}^j(x, \xi, \tau) = t_k^j(x, \xi), \quad k = 1, \dots, n, \quad j = 1, \dots, n-1,$$

as these operators do not involve any derivative, and

$$\begin{aligned} t_{k,\varphi}^n(x, \xi, \tau) &= \sum_{j=1}^d a_{d,j}^k(x) (\xi_j + i\tau \partial_{x_j} \varphi_k) \\ &= a_{d,d}^k(x) (\xi_d + \zeta_k), \end{aligned}$$

where

$$\zeta_k = i\tau \partial_{x_d} \varphi_k(x) + \sum_{j=1}^{d-1} \frac{a_{d,j}^k(x)}{a_{d,d}^k(x)} (\xi_j + i\tau \partial_{x_j} \varphi_k). \quad (3.4)$$

Observe that $\text{Im } \zeta_k$ is a function of $d\varphi_k$ near \mathcal{I} , but not of φ_k itself. As the operators P_k are elliptic, we have $a_{d,d} \neq 0$. We also have, as $a_{i,j} = a_{j,i}$,

$$\begin{aligned} p_{k,\varphi}(x, \xi, \tau) &= \sum_{j,\ell=1}^d a_{j,\ell}^k(x) (\xi_j + i\tau \partial_{x_j} \varphi_k) (\xi_\ell + i\tau \partial_{x_\ell} \varphi_k) \\ &= a_{d,d}^k(x) (\xi_d + i\tau \partial_{x_d} \varphi)^2 + 2(\xi_d + i\tau \partial_{x_d} \varphi) \sum_{\ell=1}^{d-1} a_{\ell,d}^k(x) (\xi_\ell + i\tau \partial_{x_\ell} \varphi_k) \\ &\quad + \sum_{j,\ell=1}^{d-1} a_{j,\ell}^k(x) (\xi_j + i\tau \partial_{x_j} \varphi_k) (\xi_\ell + i\tau \partial_{x_\ell} \varphi_k) \\ &= a_{d,d}^k(x) ((\xi_d + \zeta_k(x, \xi', \tau))^2 + q_k(x, \xi', \tau)) \\ &= a_{d,d}^k(x) (\xi_d + \zeta_k(x, \xi', \tau) + i\alpha_k(x, \xi', \tau)) (\xi_d + \zeta_k(x, \xi', \tau) - i\alpha_k(x, \xi', \tau)), \end{aligned}$$

where $q_k(x, \xi', \tau)$ is homogeneous of order 2 in (ξ', τ) , and $\alpha_k(x, \xi', \tau) \in \mathbb{C}$ is chosen so that $\text{Re } \alpha_k \geq 0$ and $\alpha_k^2(x, \xi', \tau) = q_k(x, \xi', \tau)$. Defining

$$\sigma_k^+(x, \xi', \tau) = -\zeta_k(x, \xi', \tau) + i\alpha_k(x, \xi', \tau), \quad \sigma_k^- = -\zeta_k(x, \xi', \tau) - i\alpha_k(x, \xi', \tau), \quad (3.5)$$

we can factorize the principal symbols of the operators

$$p_{k,\varphi}(x, \xi, \tau) = a_{d,d}^k(x) (\xi_d - \sigma_k^-(x, \xi', \tau)) (\xi_d - \sigma_k^+(x, \xi, \tau)).$$

Observe that $\text{Im } \sigma_k^+ \geq \text{Im } \sigma_k^-$ always holds. Several cases can occur, depending on the sign of the imaginary part of the roots of the $p_{k,\varphi}$, viewed as polynomials in ξ_d . To discuss the sign of the imaginary parts of the roots σ_k^\pm , we introduce the following sets

$$\begin{aligned} \Sigma^+ &= \Sigma^+(\rho') = \{k \in \{1, \dots, n\}, \text{Im } \sigma_k^+, \text{Im } \sigma_k^- \geq 0\}, \\ \Sigma^- &= \Sigma^-(\rho') = \{k \in \{1, \dots, n\}, \text{Im } \sigma_k^+, \text{Im } \sigma_k^- < 0\}, \\ \Sigma^0 &= \Sigma^0(\rho') = \{k \in \{1, \dots, n\}, \text{Im } \sigma_k^+ \geq 0, \text{Im } \sigma_k^- < 0\}. \end{aligned} \quad (3.6)$$

We recall that the covering condition holds if the matrix M built in (2.16) satisfies the rank condition (2.17). In this particular case, we have $m = n$. The $2 \times n$ sub-matrices M_k^1 are only related to operators at the boundary, and do not depend on the sign of the imaginary parts of the roots of the operators in

the interior. We detail here how to construct those matrices in the present example. The coefficients $t_{k,\varphi}^{l,i}$ of M_k^1 correspond to the coefficients of the principal symbols of the $t_{k,\varphi}^\ell$. The operators that acts on u_1 for $\ell \in \{1, \dots, m\}$ are respectively (see (3.3))

$$T_{1,\varphi}^1 = 1, T_{1,\varphi}^2 = 0, \dots, T_{1,\varphi}^{n-1} = 0, \text{ and } T_1^n = \sum_{j=1}^n a_{d,j}^1(x)(D_j + i\tau\partial_{x_j}\varphi_1(x)),$$

and the coefficients of their principal symbols written in the form (2.14) are given by

$$t_1^{1,0} = 1, t_1^{1,1} = 0, \dots, t_1^{n-1,0} = 0, t_1^{n-1,1} = 0, \text{ and } t_1^{n,0} = a_{d,d}^1\zeta_1, t_1^{n,1} = a_{d,d}^1(x),$$

with ζ_1 defined in (3.4) for $k = 1$. Then, we obtain

$$M_1^1 = \begin{pmatrix} 1 & 0 & \cdots & 0 & a_{d,d}^1\zeta_1 \\ 0 & 0 & \cdots & 0 & a_{d,d}^1 \end{pmatrix}. \quad (3.7)$$

Arguing the same way we have, for $k \in \{2, \dots, n-1\}$, we find

$$M_k^1 = \begin{pmatrix} & & & (k-1)^{\text{th}} & k^{\text{th}} & & & & & \\ 0 & \cdots & 0 & -1 & 1 & 0 & \cdots & 0 & a_{d,d}^k\zeta_k \\ 0 & \cdots & 0 & 0 & 0 & 0 & \cdots & 0 & a_{d,d}^k \end{pmatrix}$$

and

$$M_n^1 = \begin{pmatrix} 0 & 0 & \cdots & 0 & -1 & a_{d,d}^n\zeta_n \\ 0 & 0 & \cdots & 0 & 0 & a_{d,d}^n \end{pmatrix}.$$

We also detail the structure of the matrices M_k^2 in different situations depending on the cardinal of the sets given in (3.6).

- For $k \in \Sigma^0$, we have $m_k^- = 1$ and then $M_k^2 = {}^t(-\sigma_k^+, 1)$.
- For $k \in \Sigma^-$, we have $m_k^- = 2$ and then $M_k^2 = \text{Id}_2$.
- For $k \in \Sigma^+$, we have $m_k^- = 0$ and then $M_k^2 = \emptyset$, with the meaning given below (2.16).

We now investigate what configurations yield (2.17).

First case. We first focus on the case where $\text{Card } \Sigma^+ \geq 2$. Without any loss of generality, we may assume that $\{1, 2\} \subset \Sigma^+$, that is $\text{Im } \sigma_1^\pm \geq 0$ and $\text{Im } \sigma_2^\pm \geq 0$. In this case the matrices M_1^2 and M_2^2 are empty, and the matrix M reads

$$M = \left(\begin{array}{cccc|c} 1 & 0 & 0 & \cdots & a_{d,d}^1\zeta_1 \\ 0 & 0 & 0 & \cdots & a_{d,d}^1 \\ -1 & 1 & 0 & \cdots & a_{d,d}^2\zeta_2 \\ 0 & 0 & 0 & \cdots & a_{d,d}^2 \\ \hline & & * & & * \end{array} \right) \begin{array}{c} N \\ \\ \\ \\ \end{array}$$

with either $N = 0$ or $N = \emptyset$ (in the sense given after (2.16)). We then see that the second and the fourth rows are linearly dependent. As the number of lines of M is equal to $2m$, this implies that the rank

condition (2.17) fails to hold.

Second case. Here, we assume that $\Sigma^+ = \emptyset$. Consider $\ell \in \{1, \dots, n\}$. Without any loss of generality, we may assume that $\{1, \dots, \ell\} \subset \Sigma^0$ and $\{\ell + 1, \dots, n\} \subset \Sigma^-$. The matrix M then reads

$$M = \begin{pmatrix} \mathcal{A}_{2\ell}^1 & \mathcal{B}_\ell & 0 \\ \mathcal{A}_{2(n-\ell)}^2 & 0 & \text{Id}_{2(n-\ell)} \end{pmatrix},$$

where,

$$\mathcal{B}_\ell = \begin{pmatrix} -\sigma_1^+ & 0 & \dots & 0 & 0 \\ 1 & 0 & \dots & 0 & 0 \\ 0 & -\sigma_2^+ & \dots & 0 & 0 \\ 0 & 1 & \dots & 0 & 0 \\ \vdots & & & \ddots & \\ 0 & \dots & 0 & 0 & -\sigma_\ell^+ \\ 0 & \dots & 0 & 0 & 1 \end{pmatrix} \in \mathcal{M}_{2\ell, \ell}(\mathbb{C}),$$

and $\text{Id}_{2(n-\ell)}$ denotes the identity matrix of dimension $2(n-\ell)$. If $\ell = n$ we set $\text{Id}_0 = \emptyset$ in the sense given below (2.16). Moreover, for $\ell \neq 1, n$, we have

$$\mathcal{A}_{2\ell}^1 = \begin{pmatrix} & & (\ell-1)^{\text{th}} & \ell^{\text{th}} & & & \\ \begin{pmatrix} 1 & 0 & 0 & 0 & \dots & 0 & a_{d,d}^1 \zeta_1 \\ 0 & 0 & 0 & 0 & \dots & 0 & a_{d,d}^1 \\ -1 & 1 & 0 & 0 & \dots & 0 & a_{d,d}^2 \zeta_2 \\ 0 & 0 & 0 & 0 & \dots & 0 & a_{d,d}^2 \\ \vdots & & & & \ddots & & \vdots \\ 0 & \dots & -1 & 1 & \dots & 0 & a_{d,d}^\ell \zeta_\ell \\ 0 & \dots & 0 & 0 & \dots & 0 & a_{d,d}^\ell \end{pmatrix} \end{pmatrix} \in \mathcal{M}_{2\ell, n}(\mathbb{C}),$$

and

$$\mathcal{A}_{2(n-\ell)}^2 = \begin{pmatrix} & & (\ell)^{\text{th}} & (\ell+1)^{\text{th}} & & & \\ \begin{pmatrix} 0 & \dots & -1 & 1 & \dots & 0 & a_{d,d}^{\ell+1} \zeta_{\ell+1} \\ 0 & \dots & 0 & 0 & \dots & 0 & a_{d,d}^{\ell+1} \\ 0 & \dots & 0 & -1 & \dots & 0 & a_{d,d}^{\ell+2} \zeta_{\ell+2} \\ 0 & \dots & 0 & 0 & \dots & 0 & a_{d,d}^{\ell+2} \\ \vdots & & & & \ddots & & \vdots \\ 0 & \dots & 0 & 0 & \dots & -1 & a_{d,d}^n \zeta_n \\ 0 & \dots & 0 & 0 & \dots & 0 & a_{d,d}^n \end{pmatrix} \end{pmatrix} \in \mathcal{M}_{2(n-\ell), n}(\mathbb{C}).$$

For $\ell = 1$, we have

$$\mathcal{A}_{2\ell}^1 = \begin{pmatrix} 1 & 0 & 0 & 0 & \dots & 0 & a_{d,d}^1 \zeta_1 \\ 0 & 0 & 0 & 0 & \dots & 0 & a_{d,d}^1 \end{pmatrix} \in \mathcal{M}_{2, n}(\mathbb{C}),$$

$$\mathcal{A}_{2(n-\ell)}^2 = \begin{pmatrix} -1 & 1 & \dots & 0 & a_{d,d}^{\ell+1} \zeta_{\ell+1} \\ 0 & 0 & \dots & 0 & a_{d,d}^{\ell+1} \\ 0 & -1 & \dots & 0 & a_{d,d}^{\ell+2} \zeta_{\ell+2} \\ 0 & 0 & \dots & 0 & a_{d,d}^{\ell+2} \\ \vdots & & \ddots & & \vdots \\ 0 & 0 & \dots & -1 & a_{d,d}^n \zeta_n \\ 0 & 0 & \dots & 0 & a_{d,d}^n \end{pmatrix} \in \mathcal{M}_{2(n-1), n}(\mathbb{C}).$$

Finally, for $\ell = n$, we have

$$\mathcal{A}_{2n}^1 = \begin{pmatrix} 1 & 0 & 0 & 0 & \dots & 0 & a_{d,d}^1 \zeta_1 \\ 0 & 0 & 0 & 0 & \dots & 0 & a_{d,d}^1 \\ -1 & 1 & 0 & 0 & \dots & 0 & a_{d,d}^2 \zeta_2 \\ 0 & 0 & 0 & 0 & \dots & 0 & a_{d,d}^2 \\ \vdots & & & & \ddots & \vdots & \vdots \\ 0 & \dots & 0 & 0 & \dots & -1 & a_{d,d}^n \zeta_n \\ 0 & \dots & 0 & 0 & \dots & 0 & a_{d,d}^n \end{pmatrix} \in \mathcal{M}_{2n,n}(\mathbb{C}), \quad \mathcal{A}_{2(n-\ell)}^2 = \emptyset.$$

Note that we have

$$\text{Rank}(M) = \text{Rank}(T) + 2(n - \ell), \quad \text{with } T = \text{Rank}(\mathcal{A}_{2\ell} \ \mathcal{B}_\ell). \quad (3.8)$$

By operations on the lines and columns of the $2\ell \times (n + \ell)$ matrix T we can obtain:

- If $\ell < n$, it is of maximal rank. Indeed, from (3.8), this is equivalent to have $\text{Rank}(M) = \text{Rank}(\mathcal{A}_{2\ell}^1 \ \mathcal{B}_\ell) = 2\ell$. Yet, by reorganizing columns, we have

$$\begin{aligned} \text{Rank}(\mathcal{A}_{2\ell}^1 \ \mathcal{B}_\ell) &= \text{Rank} \begin{pmatrix} 1 & -\sigma_1^+ & 0 & 0 & \dots & 0 & 0 & a_{d,d}^1 \zeta_1 \\ 0 & 1 & 0 & 0 & \dots & 0 & 0 & a_{d,d}^1 \\ -1 & 0 & 1 & -\sigma_2^+ & \dots & 0 & 0 & a_{d,d}^2 \zeta_2 \\ 0 & 0 & 0 & 1 & \dots & 0 & 0 & a_{d,d}^2 \\ \vdots & \vdots & & & \ddots & & & \vdots \\ 0 & 0 & 0 & 0 & \dots & 1 & -\sigma_\ell^+ & a_{d,d}^\ell \zeta_\ell \\ 0 & 0 & 0 & 0 & \dots & 0 & 1 & a_{d,d}^\ell \end{pmatrix} \\ &= \text{Rank} \begin{pmatrix} 1 & 0 & 0 & 0 & \dots & 0 & 0 & a_{d,d}^1(\zeta_1 + \sigma_1^+) \\ 0 & 1 & 0 & 0 & \dots & 0 & 0 & a_{d,d}^1 \\ -1 & 0 & 1 & 0 & \dots & 0 & 0 & a_{d,d}^2(\zeta_2 + \sigma_2^+) \\ 0 & 0 & 0 & 1 & \dots & 0 & 0 & a_{d,d}^2 \\ \vdots & \vdots & & & \ddots & & & \vdots \\ 0 & 0 & 0 & 0 & \dots & 1 & 0 & a_{d,d}^\ell(\zeta_\ell + \sigma_\ell^+) \\ 0 & 0 & 0 & 0 & \dots & 0 & 1 & a_{d,d}^\ell \end{pmatrix} \\ &\geq \text{Rank} \begin{pmatrix} 1 & 0 & 0 & 0 & \dots & 0 & 0 \\ 0 & 1 & 0 & 0 & \dots & 0 & 0 \\ -1 & 0 & 1 & 0 & \dots & 0 & 0 \\ 0 & 0 & 0 & 1 & \dots & 0 & 0 \\ \vdots & \vdots & & & \ddots & & \\ 0 & 0 & 0 & 0 & \dots & 1 & 0 \\ 0 & 0 & 0 & 0 & \dots & 0 & 1 \end{pmatrix} = 2\ell, \end{aligned}$$

as the final matrix is in $\mathcal{M}_{2\ell}(\mathbb{C})$.

- If $\ell = n$, it is of maximal rank if and only if

$$\sum_{j=1}^n a_{d,d}^j (\zeta_j + \sigma_j^+) \neq 0. \quad (3.9)$$

Indeed, from (3.8), this is equivalent to have $\text{Rank}(\mathcal{A}_{2n} \ \mathcal{B}_n) = 2n$. Yet,

$$\begin{aligned}
& \text{Rank}(\mathcal{A}_{2n}^1 \ \mathcal{B}_n) \\
&= \text{Rank} \begin{pmatrix} 1 & 0 & 0 & 0 & \dots & 0 & a_{d,d}^1 \zeta_1 & -\sigma_1^+ & 0 & \dots & 0 & 0 \\ 0 & 0 & 0 & 0 & \dots & 0 & a_{d,d}^1 & 1 & 0 & \dots & 0 & 0 \\ -1 & 1 & 0 & 0 & \dots & 0 & a_{d,d}^2 \zeta_2 & 0 & -\sigma_2^+ & \dots & 0 & 0 \\ 0 & 0 & 0 & 0 & \dots & 0 & a_{d,d}^2 & 0 & 1 & \dots & 0 & 0 \\ \vdots & & & & \ddots & \vdots & \vdots & \vdots & \vdots & & \ddots & \\ 0 & \dots & -0 & 0 & \dots & -1 & a_{d,d}^n \zeta_n & 0 & \dots & 0 & 0 & -\sigma_n^+ \\ 0 & \dots & 0 & 0 & \dots & 0 & a_{d,d}^n & 0 & \dots & 0 & 0 & 1 \end{pmatrix} \\
&= \text{Rank} \begin{pmatrix} 1 & 0 & 0 & 0 & \dots & 0 & a_{d,d}^1(\zeta_1 + \sigma_1^+) & -\sigma_1^+ & 0 & \dots & 0 & 0 \\ 0 & 0 & 0 & 0 & \dots & 0 & 0 & 1 & 0 & \dots & 0 & 0 \\ -1 & 1 & 0 & 0 & \dots & 0 & a_{d,d}^2(\zeta_2 + \sigma_2^+) & 0 & -\sigma_2^+ & \dots & 0 & 0 \\ 0 & 0 & 0 & 0 & \dots & 0 & 0 & 0 & 1 & \dots & 0 & 0 \\ \vdots & & & & \ddots & \vdots & \vdots & \vdots & \vdots & & \ddots & \\ 0 & \dots & -0 & 0 & \dots & -1 & a_{d,d}^n(\zeta_n + \sigma_n^+) & 0 & \dots & 0 & 0 & -\sigma_n^+ \\ 0 & \dots & 0 & 0 & \dots & 0 & 0 & 0 & \dots & 0 & 0 & 1 \end{pmatrix} \\
&= \text{Rank} \begin{pmatrix} 1 & 0 & 0 & 0 & \dots & 0 & a_{d,d}^1(\zeta_1 + \sigma_1^+) \\ -1 & 1 & 0 & 0 & \dots & 0 & a_{d,d}^2(\zeta_2 + \sigma_2^+) \\ 0 & -1 & 1 & 0 & \dots & 0 & a_{d,d}^3(\zeta_3 + \sigma_3^+) \\ 0 & 0 & -1 & 1 & \dots & 0 & a_{d,d}^4(\zeta_4 + \sigma_4^+) \\ \vdots & \vdots & & & \ddots & & \\ 0 & 0 & 0 & 0 & \dots & 1 & a_{d,d}^{n-1}(\zeta_{n-1} + \sigma_{n-1}^+) \\ 0 & 0 & 0 & 0 & \dots & -1 & a_{d,d}^n(\zeta_n + \sigma_n^+) \end{pmatrix} + n,
\end{aligned}$$

and we see that (3.9) is a necessary and sufficient condition to obtain the rank condition (2.17). Let us prove that (3.9) is always satisfied. If not, we have

$$\sum_{j=1}^n a_{d,d}^j \text{Im} \zeta_j = - \sum_{j=1}^n a_{d,d}^j \text{Im} \sigma_j^+.$$

Yet, $\text{Im} \sigma_j^+ = -\text{Im} \zeta_j + \text{Re} \alpha_j$. This implies $\sum_{j=1}^n a_{d,d}^j \text{Re} \alpha_j = 0$. As $\text{Re} \alpha_j \geq 0$ and $a_{d,d}^j > 0$ for all $j \in \{1, \dots, n\}$, then $\text{Re} \alpha_j = 0$. Hence, both roots σ_j^+ and σ_j^- have the same imaginary part, for all $j \in \{1, \dots, n\}$, in contradiction with having $\{1, \dots, n\} \subset \Sigma^0$.

As a result, the covering condition holds in this case.

Third case. In this case, we assume that $\text{Card} \Sigma^+ = 1$ and $\text{Card} \Sigma^0 = n - 1$. In such a situation, the matrix has only $2n - 1$ columns, and from Remark 2.7, the covering condition fails to hold.

Fourth case. We finally assume $\text{Card} \Sigma^+ = 1$ and $\text{Card} \Sigma^0 < n - 1$ (or equivalently $\text{Card} \Sigma^- \geq 1$). Let $\ell = \text{Card} \Sigma^0$ and assume, without any loss of generality, $\{1, \dots, \ell\} = \Sigma^0$, $\{\ell + 1, \dots, n - 1\} = \Sigma^-$, and $\{n\} = \Sigma^+$. Then the matrix M reads

$$M = (\mathcal{A} \ \mathcal{B})$$

where

$$\mathcal{A} = \begin{pmatrix} M_1^1 \\ \vdots \\ M_n^1 \end{pmatrix} = \begin{pmatrix} 1 & 0 & 0 & 0 & \dots & 0 & a_{d,d}^1 \zeta_1 \\ 0 & 0 & 0 & 0 & \dots & 0 & a_{d,d}^1 \\ -1 & 1 & 0 & 0 & \dots & 0 & a_{d,d}^2 \zeta_2 \\ 0 & 0 & 0 & 0 & \dots & 0 & a_{d,d}^2 \\ \vdots & & & & \ddots & \vdots & \vdots \\ 0 & \dots & 0 & 0 & \dots & -1 & a_{d,d}^n \zeta_n \\ 0 & \dots & 0 & 0 & \dots & 0 & a_{d,d}^n \end{pmatrix} \in \mathcal{M}_{2n,n}(\mathbb{C}),$$

and

$$\mathcal{B} = \begin{pmatrix} M_1^2 & & \\ & \ddots & \\ & & M_{n-1}^2 \\ 0 & \dots & 0 \\ 0 & \dots & 0 \end{pmatrix} = \begin{pmatrix} -\sigma_1^+ & 0 & 0 & 0 & \dots & 0 & 0 \\ 1 & \ddots & 0 & 0 & & \vdots & \vdots \\ 0 & \ddots & -\sigma_\ell^+ & 0 & \dots & 0 & 0 \\ 0 & 0 & 1 & 0 & 0 & 0 & 0 \\ 0 & 0 & 0 & 1 & 0 & 0 & 0 \\ \vdots & & \vdots & 0 & 1 & 0 & 0 \\ 0 & \dots & 0 & \vdots & 0 & \ddots & 0 \\ 0 & \dots & 0 & 0 & 0 & 0 & 1 \\ 0 & \dots & 0 & 0 & 0 & 0 & 0 \\ 0 & \dots & 0 & 0 & 0 & 0 & 0 \end{pmatrix} \in \mathcal{M}_{2n,2n-\ell-2}(\mathbb{C}),$$

as $M_n^2 = \emptyset$. We shall make operations on lines and columns to compute the rank of M . First, note that using the last line of M , we obtain $\text{Rank } M = \text{Rank}(\mathcal{A}' \ \mathcal{B})$, with

$$\mathcal{A}' = \begin{pmatrix} 1 & 0 & 0 & 0 & \dots & 0 & 0 \\ 0 & 0 & 0 & 0 & \dots & 0 & 0 \\ -1 & 1 & 0 & 0 & \dots & 0 & 0 \\ 0 & 0 & 0 & 0 & \dots & 0 & 0 \\ \vdots & & & & \ddots & \vdots & \vdots \\ 0 & \dots & 0 & 0 & \dots & -1 & 0 \\ 0 & \dots & 0 & 0 & \dots & 0 & 1 \end{pmatrix}.$$

Then using the even lines of \mathcal{B} , as the associated lines of \mathcal{A}' are only made of zeros, we obtain $\text{Rank } M = \text{Rank}(\mathcal{A}' \ \mathcal{B}')$, with

$$\mathcal{B}' = \begin{pmatrix} 0 & 0 & 0 & 0 & \dots & 0 & 0 \\ 1 & \ddots & 0 & 0 & & \vdots & \vdots \\ 0 & \ddots & 0 & 0 & \dots & 0 & 0 \\ 0 & 0 & 1 & 0 & 0 & 0 & 0 \\ 0 & 0 & 0 & 1 & 0 & 0 & 0 \\ \vdots & & \vdots & 0 & 1 & 0 & 0 \\ 0 & \dots & 0 & \vdots & 0 & \ddots & 0 \\ 0 & \dots & 0 & 0 & 0 & 0 & 1 \\ 0 & \dots & 0 & 0 & 0 & 0 & 0 \\ 0 & \dots & 0 & 0 & 0 & 0 & 0 \end{pmatrix},$$

and we see that the rank of $(\mathcal{A}' \quad \mathcal{B}')$, is equal to $2n$.

Conclusion. As the four cases we considered are exhaustive, we find that we have to construct a weight function φ such that the first and third cases described above do not occur, meaning that we require

$$\text{Card } \Sigma^+(\rho') \leq 1, \quad \forall \rho' \in \mathcal{I}, \quad (3.10)$$

and moreover

$$\text{Card } \Sigma(\rho') = 1 \implies \text{Card } \Sigma^0(\rho') < n - 1 \text{ (or equivalently } \text{Card } \Sigma^-(\rho') \geq 1). \quad (3.11)$$

Let $i_0 \in \{1, \dots, n\}$ be fixed. First note that if we have, for all $i \neq i_0$,

$$-\tau(\partial_{x_d}\varphi_i + \sum_{j=1}^{d-1} a_{d,j}^i/a_{d,d}^i \partial_{x_j}\varphi_i) < 0, \quad (3.12)$$

then (3.10) is satisfied as $\text{Im } \sigma_k^- = -\tau(\partial_{x_d}\varphi_i + \sum_{j=1}^{d-1} a_{d,j}^i/a_{d,d}^i \partial_{x_j}\varphi_i) - \text{Re } \alpha_i$ with $\text{Re } \alpha_i \geq 0$. Second, observe that $\text{Im } \sigma_{i_0}^- \geq 0$ implies

$$-\tau(\partial_{x_d}\varphi_{i_0} + \sum_{j=1}^{d-1} a_{d,j}^{i_0}/a_{d,d}^{i_0} \partial_{x_j}\varphi_{i_0}) \geq \text{Re } \alpha_{i_0} \geq 0.$$

Hence, if we construct a weight function φ satisfying

$$\begin{aligned} -\tau(\partial_{x_d}\varphi_{i_0} + \sum_{j=1}^{d-1} a_{d,j}^{i_0}/a_{d,d}^{i_0} \partial_{x_j}\varphi_{i_0}) &\geq \text{Re } \alpha_{i_0} \\ \implies \begin{cases} -\tau(\partial_{x_d}\varphi_{i_1} + \sum_{j=1}^{d-1} a_{d,j}^{i_1}/a_{d,d}^{i_1} \partial_{x_j}\varphi_{i_1}) < -\text{Re } \alpha_{i_1}, \\ -\tau(\partial_{x_d}\varphi_i + \sum_{j=1}^{d-1} a_{d,j}^i/a_{d,d}^i \partial_{x_j}\varphi_i) < \text{Re } \alpha_i, \quad \forall i \neq i_0, i_1, \end{cases} \end{aligned} \quad (3.13)$$

for some $i_1 \neq i_0$, then both (3.10) and (3.11) hold. Observe that (3.13) can be achieved by requiring (3.12) and additionally

$$(\text{Re } \alpha_{i_1}) \frac{\partial_{x_d}\varphi_{i_0} + \sum_{j=1}^{d-1} a_{d,j}^{i_0}/a_{d,d}^{i_0} \partial_{x_j}\varphi_{i_0}}{\partial_{x_d}\varphi_{i_1} + \sum_{j=1}^{d-1} a_{d,j}^{i_1}/a_{d,d}^{i_1} \partial_{x_j}\varphi_{i_1}} < \text{Re } \alpha_{i_0}. \quad (3.14)$$

In order to fix ideas, assume that $\varphi_k = \varphi_k(x_d)$ does not depend on the variable x' . Then, conditions (3.12) and (3.14) read

$$\forall i \neq i_0, \quad \partial_{x_d}\varphi_i > 0, \quad \text{and} \quad \frac{\partial_{x_d}\varphi_{i_0}}{\partial_{x_d}\varphi_{i_1}} < K,$$

where K is a positive constant that only depends on the coefficients $a_{j,\ell}^{i_0}$ and $a_{j,\ell}^{i_1}$. Hence, if we choose a weight function φ such that, near the interface,

$$\partial_{x_d}\varphi_{i_0} < 0, \quad \text{and} \quad \partial_{x_d}\varphi_i > 0, \quad \text{for } i \neq i_0, \quad \text{and moreover satisfying } \partial_{x_d}\varphi_{i_1} \gg \partial_{x_d}\varphi_{i_0} \text{ for some } i_1 \neq i_0, \quad (3.15)$$

then the covering condition is satisfied. Allowing back a dependance with respect to the variable x' is possible, for instance, if we impose $|\nabla'\varphi_k| \ll |\partial_{x_d}\varphi_k|$, for all $k \neq i_0$.

Remark 3.1. *In applications, this means that if we want to observe the interface, according to Theorem 2.6, the observation has to be made from at least $n - 1$ sides of \mathcal{I} (we recall that in Carleman estimates and applications, the observation region corresponds to regions where the weight function is the largest).*

3.2 On the optimality of the observation regions for the transmission problem

In this section, we discuss the optimality of the above conditions on the weight function. First, observe that in the case of two operators ($n = 2$), we precisely recover the condition of [7], which is proven to be optimal in the case of operators with constant coefficients in [22]. Second, in some particular geometric configurations, note that if we observe from only $n - 2$ sides of \mathcal{I} , then the unique continuation property may fail, which prevents the possibility of proving a Carleman estimate. We consider $\Omega_k = (\mathbb{R}/2\pi\mathbb{Z}) \times (0, \pi)$, for $k \in \{1, \dots, n\}$, $n \in \mathbb{N}^*$, $n \geq 3$, and $\mathcal{I} = (\mathbb{R}/2\pi\mathbb{Z}) \times \{0\}$. Take $C_k = \begin{pmatrix} 1 & 0 \\ 0 & c_k \end{pmatrix}$, such that $c_k^{-1/2} \in \mathbb{N}^*$, and consider the diagonal operator

$$\mathcal{Q} = \begin{pmatrix} -\operatorname{div}(C_1 \nabla) & 0 & \dots & 0 \\ 0 & -\operatorname{div}(C_2 \nabla) & 0 & 0 \\ \vdots & & \ddots & \\ 0 & 0 & \dots & -\operatorname{div}(C_n \nabla) \end{pmatrix} \quad (3.16)$$

with domain

$$D(\mathcal{Q}) = \left\{ (u_1, \dots, u_n) \in \bigoplus_{k=1}^n H^2(\Omega_k), u_1 = \dots = u_n \text{ on } \mathcal{I}, \sum_{k=1}^n c_k \partial_{x_2} u_k|_{x_2=0} = 0 \text{ on } \mathcal{I} \right\}.$$

We have the following proposition on the eigenfunctions of \mathcal{Q} .

Proposition 3.2. *For all $j \in \mathbb{N}$ and $\ell \in \{2, \dots, n - 1\}$, the function*

$$\phi_j = \begin{pmatrix} 0 \\ \vdots \\ 0 \\ e^{ijx_1} \sin(c_\ell^{-1/2} jx_2) \\ e^{ijx_1} \sin(c_{\ell+1}^{-1/2} jx_2) \\ \vdots \\ e^{ijx_1} \sin(c_{n-1}^{-1/2} jx_2) \\ -c_n^{1/2} \sum_{k=\ell}^{n-1} c_k^{1/2} e^{ijx_1} \sin(c_n^{-1/2} jx_2) \end{pmatrix}$$

where the first $\ell - 1$ components are equal to zero, is an eigenfunction for System (3.16) associated with the eigenvalues j^2 .

If $\ell \in \{1, \dots, n - 1\}$, the eigenfunction has $\ell - 1$ vanishing components. In the particular case $\ell = n - 1$, the eigenfunction has $n - 2$ vanishing components. Thus, Proposition 3.2 shows that the unique continuation property fails to hold from less than $n - 1$ sides of the interface, due to the presence of such *invisible* modes. Since a Carleman estimate near the interface as in Theorem 2.6 implies the unique continuation property, the derivation of the Carleman estimate cannot be achieved in this geometrical configuration. Using Remark 3.1, this means that in (3.15), having $\partial_{x_d} \varphi_{i_0} > 0$, for $i \in J \subset \{1, \dots, n\}$ with $\operatorname{Card} J \geq n - 1$, is necessary. However, in the example (3.16), this is mainly due to the symmetry of the domains Ω_k . The investigation of general configurations where the unique continuation property holds true remains an interesting question.

4 Carleman estimate in a neighborhood of the interface

4.1 Semi-classical calculus

4.1.1 Classes of symbols

We recall some classes of pseudo-differential operators that we use in what follows. This allows us to introduce some important notation. As above, we write $\rho = (x, \xi, \tau) \in \bar{U} \times \mathbb{R}^d \times \mathbb{R}^+$ and $\rho' = (x, \xi', \tau) \in \bar{U} \times \mathbb{R}^{d-1} \times \mathbb{R}^+$.

Definition 4.1. *The symbol class \mathcal{S}_τ^m is the space of $a(\rho) \in C^\infty(\mathbb{R}^d \times \mathbb{R}^d)$ that depends on the large parameter $\tau \geq 1$ satisfying for all multi-indices $\alpha, \beta \in \mathbb{N}^d$*

$$|\partial_x^\alpha \partial_\xi^\beta a(\rho)| \leq C_{\alpha, \beta} \lambda^{m-|\beta|}, \quad \text{for all } x \in \mathbb{R}^d, \xi \in \mathbb{R}^d, \tau \geq 1,$$

where λ is the order function $\lambda = (\tau^2 + |\xi^2|)^{1/2}$. The principal symbol of such a , denoted by $\sigma(a)(\rho)$ is the class of a in the quotient space $\mathcal{S}_\tau^m / \mathcal{S}_\tau^{m-1}$.

We also introduce the tangential symbol class $\mathcal{S}_{T, \tau}^m$ as the space of $a(\rho') \in C^\infty(\mathbb{R}^d \times \mathbb{R}^{d-1})$ that depends on the large parameter $\tau \geq 1$ satisfying for all multi-indices $\alpha \in \mathbb{N}^d, \beta \in \mathbb{N}^{d-1}$

$$|\partial_x^\alpha \partial_{\xi'}^\beta a(\rho)| \leq C_{\alpha, \beta} \lambda_T^{m-|\beta|}, \quad \text{for all } x \in \mathbb{R}^d, \xi' \in \mathbb{R}^{d-1}, \tau \geq 1,$$

where λ_T is the order function $\lambda_T = (\tau^2 + |\xi'^2|)^{1/2}$. The principal symbol of such a , also denoted by $\sigma(a)(\rho)$ is the class of a in the quotient space $\mathcal{S}_{T, \tau}^m / \mathcal{S}_{T, \tau}^{m-1}$.

We shall consider symbols that are polynomials in the ξ_d -variable with coefficients in the class of tangential symbols. More precisely, we consider $\mathcal{S}_\tau^{m, r}$ the space of $a(\rho) \in C^\infty(\mathbb{R}^d \times \mathbb{R}^d)$ that depends on the large parameter $\tau \geq 1$, and such that

$$a(\rho) = \sum_{j=0}^m a_j(\rho') \xi_d^j, \quad a_j \in \mathcal{S}_{T, \tau}^{m-j+r}. \quad (4.1)$$

The principal symbol of such a , denoted by $\sigma(a)(\rho)$ is defined by

$$\sigma(a)(\rho) = \sum_{j=1}^m \sigma(a_j)(\rho') \xi_d^j.$$

It can be understood as a representative of a in $\mathcal{S}_\tau^{m, r} / \mathcal{S}_\tau^{m, r-1}$.

We also introduce poly-homogeneous symbols.

Definition 4.2. *We say that $a \in \mathcal{S}_{\tau, \text{cl}}^m$ (resp. $\mathcal{S}_{T, \tau, \text{cl}}^m$) if there exist $a_j \in \mathcal{S}_\tau^{m-j}$ (resp. $\mathcal{S}_{T, \tau}^{m-j}$), $j \in \mathbb{N}$, homogeneous of degree $m-j$ in (ξ, τ) (resp. (ξ', τ)) such that, for all $j_0 \in \mathbb{N}$,*

$$a - \sum_{j=0}^{j_0} a_j \in \mathcal{S}_\tau^{m-j_0-1}, \quad (\text{resp. } \mathcal{S}_{T, \tau}^{m-j_0-1}).$$

We say that $a \in \mathcal{S}_{\tau, \text{cl}}^{m, r}$ if

$$a(\rho) = \sum_{j=0}^m a_j(\rho') \xi_d^j, \quad \text{with } a_j^m \in \mathcal{S}_{T, \tau, \text{cl}}^{m-j+r}.$$

4.1.2 Semi-classical pseudo-differential operators

For u in the Schwartz space $\mathcal{S}(\mathbb{R}^d)$, we denote by \hat{u} the Fourier transform, that is,

$$\hat{u}(\xi) = \int_{\mathbb{R}^d} e^{-ix \cdot \xi} u(x) dx.$$

Definition 4.3. For $a \in \mathcal{S}_\tau^m$ (resp. $\mathcal{S}_{\tau, \text{cl}}^m$) we define the pseudo-differential operator

$$\text{Op}(a)u(x) = \frac{1}{(2\pi)^d} \int_{\mathbb{R}^d} e^{ix \cdot \xi} a(x, \xi, \tau) \hat{u}(\xi) d\xi = \frac{1}{(2\pi)^d} \int_{\mathbb{R}^d} \int_{\mathbb{R}^d} e^{i(x-y) \cdot \xi} a(x, \xi, \tau) u(y) dy d\xi,$$

for all $u \in \mathcal{S}(\mathbb{R}^d)$, and we write $\text{Op}(a) \in \Psi_\tau^m$ (resp. $\Psi_{\tau, \text{cl}}^m$). The principal symbol of the pseudo-differential operator $\text{Op}(a)$ is $\sigma(\text{Op}(a)) = \sigma(a)$ (see Definition 4.1 and 4.2). We also define tangential pseudo-differential associated with a symbol $b \in \mathcal{S}_{T, \tau}^m$ (resp. $\mathcal{S}_{T, \tau, \text{cl}}^m$) by

$$\text{Op}_T(b)u(x) = \frac{1}{(2\pi)^{d-1}} \int_{\mathbb{R}^{d-1}} \int_{\mathbb{R}^{d-1}} e^{i(x'-y') \cdot \xi'} b(x, \xi', \tau) u(y', x_n) dy' d\xi',$$

for $u \in \mathcal{S}(\mathbb{R}^d)$ and $x \in \mathbb{R}_+^d$, and we write $\text{Op}_T(b) \in \Psi_{T, \tau}^m$ (resp. $\Psi_{T, \tau, \text{cl}}^m$). The principal symbol of the pseudo-differential operator $\text{Op}_T(b)$ is $\sigma(\text{Op}_T(b)) = \sigma(b)$ (see Definition 4.1 and 4.2).

4.1.3 Sobolev norms

For $s \in \mathbb{N}^*$ and $\tau \geq 1$ we introduce the following parameter dependent Sobolev norms

$$\|\cdot\|_{s, \tau}^2 = \sum_{k=0}^n \sum_{t=0}^s \tau^{2(m-t)} \|\cdot\|_{H^t(\Omega_k)}^2, \quad \text{and} \quad |\cdot|_{s, \tau}^2 = \sum_{t=0}^s \tau^{2(s-t)} |\cdot|_{H^t(\mathcal{I})}^2, \quad (4.2)$$

where $\|\cdot\|_{H^t(\Omega_k)}$ and $|\cdot|_{H^t(\mathcal{I})}$ denotes the standard Sobolev spaces in Ω_k and on the interface \mathcal{I} respectively. We define the Sobolev spaces $H_\tau^m(\Omega_k)$ and $H_\tau^m(\mathcal{I})$ as the completion of $C^\infty(\Omega_k)$ and $C^\infty(\mathcal{I})$, the spaces of smooth functions, with respect to the norms (4.2). Algebraically, the spaces $H_\tau^m(\Omega_k)$ and $H_\tau^m(\mathcal{I})$ are equal to the standard Sobolev spaces. However, they are not endowed with equivalent norm in the semi-classical limit $\tau \rightarrow +\infty$. As we deal with operators with orders $2m_k \geq 2$, we shall need to estimate traces of the solution and its iterated normal derivatives at \mathcal{I} . Hence, we introduce the Hilbert sum

$$H_\tau^{m, s} = \bigoplus_{j=0}^m H^{m-j+s}(\mathcal{I}),$$

endowed with the norm

$$|U|_{m, s, \tau}^2 = \sum_{j=0}^m |u_j|_{m-j+s, \tau}^2, \quad \text{with } U = (u_0, \dots, u_m). \quad (4.3)$$

We shall also apply this norm to the following vectors composed of the various traces of iterated normal derivatives of a function $u \in C^\infty(\Omega_k)$ as

$$\text{tr}^m(u) = (u|_{\mathcal{I}}, D_\nu u|_{\mathcal{I}}, \dots, D_\nu^m u|_{\mathcal{I}}), \quad \text{where } D_\nu = -i\partial_\nu \text{ and } \nu \in N_k^*(\mathcal{I}),$$

(for the definition of $N_k^*(\mathcal{I})$ we refer to the beginning of Section 2.2). However, for the sake of simplicity, we shall write $|\text{tr} u|_{m, s, \tau}$ instead of $|\text{tr}^m(u)|_{m, s, \tau}$, whenever no ambiguity may occur.

We introduce the space of smooth functions in the half space, with rapid decay at infinity

$$\mathcal{S}(\overline{\mathbb{R}}_+^d) = \{u|_{x_d > 0}, u \in \mathcal{S}(\mathbb{R}^d)\},$$

that is the space of restrictions to the half space of functions in the Schwartz space. Pseudo-differential operators that behave polynomially in the ξ_d direction such as (4.1) may act on functions of $\mathcal{S}(\overline{\mathbb{R}}_+^d)$. Hence, we introduce the norms in \mathbb{R}_+^d

$$\|u\|_{m,s,\tau}^2 = \|\text{Op}_T(\lambda_T^s)u\|_{m,\tau}^2, \quad u \in \mathcal{S}(\overline{\mathbb{R}}_+^d),$$

with $\|\cdot\|_{m,\tau}$ introduced in (4.2), and the norm at the interface $\mathcal{I} = \{x_d = 0\} \simeq \mathbb{R}^{d-1}$

$$|U|_{m,s,\tau}^2 = \sum_{j=0}^m |\text{Op}_T(\lambda_T^s)u_j|_{m-j,\tau}^2, \quad U = (u_0, \dots, u_m) \in (\mathcal{S}(\mathbb{R}^{d-1}))^{m+1},$$

with $|\cdot|_{m-j,\tau}$ given by (4.2). In what follows, we shall denote the inner product of $L^2(\mathbb{R}_+^d)$ and $L^2(\mathbb{R}^{d-1})$ by

$$(f, g)_+ = \int_{\mathbb{R}_+^d} f \bar{g}, \quad (u, v)_\partial = \int_{\mathbb{R}^{d-1}} u \bar{v},$$

respectively, for $f, g \in L^2(\mathbb{R}_+^d)$ and $u, v \in L^2(\mathbb{R}^{d-1}) \simeq L^2(\mathcal{I})$. We shall also write

$$\|f\|_+^2 := \int_{\mathbb{R}_+^d} |f|^2.$$

We state the following continuity results for the classes of pseudo-differential operators introduced in Section 4.1.2.

Proposition 4.4. *Let $a(\rho) \in \mathcal{S}_\tau^{m,s}$. Then, for every $m' \in \mathbb{N}$ and $s' \in \mathbb{R}$ there exists a constant $C > 0$ such that*

$$\|\text{Op}(a)u\|_{m',s',\tau} \leq C \|u\|_{m'+m,s'+s,\tau},$$

for all $u \in \mathcal{S}(\overline{\mathbb{R}}_+^d)$.

4.2 Sub-elliptic estimate near the interface

The following estimation is classical and based on integration by parts. It describes how the sub-ellipticity property yields an estimation, here with the case of a quadratic form $\text{Re} \left(Av, iBv \right)_+$.

Lemma 4.5. *Let U be an open subset of \overline{V}^+ . Let $a \in \mathcal{S}_\tau^{m,0}$ and $b \in \mathcal{S}_\tau^{m-1,1}$ be real symbols homogeneous of degree m in (ξ, τ) . Set*

$$Q_{a,b}(v) = 2 \text{Re} \left(Av, iBv \right)_+, \quad A = \text{Op}(a), \quad B = \text{Op}(b). \quad (4.4)$$

Assume that

$$a(\rho) = b(\rho) = 0 \implies \{a, b\} > 0$$

for $x \in \overline{U}$, for $(\xi, \tau) \neq 0$. Then there exists $C, C', \tau_0 > 0$ such that

$$C \|v\|_{m,\tau}^2 \leq C' \left(\|Av\|_+^2 + \|Bv\|_+^2 + |\text{tr} v|_{m-1,1/2,\tau}^2 \right) + \tau (Q_{a,b}(v) - \text{Re} \mathcal{B}_{a,b}(v)),$$

for $\tau \geq \tau_0$, for all $v \in C^\infty(\overline{\mathbb{R}}_+^d)$ with $\text{supp} v \subset U$, and where $\mathcal{B}_{a,b}$ is a quadratic form at the interface $\{x_d = 0\}$, satisfying

$$|\mathcal{B}_{a,b}(v)| \leq C' |\text{tr} v|_{m-1,1/2,\tau}^2.$$

A proof of this result can be found in [6].

4.3 An elliptic estimate near the interface

We consider, on \mathbb{R}_+^d ,

$$P_{k,\varphi} = e^{\tau\varphi_k} P_k e^{-\tau\varphi_k} \in \Psi_\tau^{2m_k,0},$$

of principal symbol $p_{k,\varphi}(\rho) = p_k(x, \xi + i\tau d\varphi_k(x)) \in \mathcal{S}_\tau^{2m_k,0}$, where p_k denotes the principal symbol of P_k . We also define at the boundary

$$T_{k,\varphi}^j = e^{\tau\varphi_k} T_k^j e^{-\tau\varphi_k} \in \Psi_\tau^{\beta_k^j,0},$$

of principal symbol $t_{k,\varphi}^j(\rho) = t_k^j(x, \xi + i\tau d\varphi_k(x)) \in \mathcal{S}_\tau^{\beta_k^j,0}$, where t_k^j denotes the principal symbol of T_k^j . Considering an operator with principal symbol with roots that have negative imaginary parts, we may obtain an estimate of all the relevant traces at the boundary (or the interface) without the use of any boundary condition. This is the result of the following lemma, which proof can be found in [6].

Lemma 4.6. *Let $h(\rho', \xi_d) \in \mathcal{S}_\tau^{k,0}$, with $k \geq 1$, be a monic polynomial function in ξ_d with homogeneous coefficients in (ξ', τ) and $H = \text{Op}(h)$. Let U be a conic open subset of $\overline{V}^+ \times \mathbb{R}^{d-1} \times \mathbb{R}^+$. Assume that all the roots of h have negative imaginary part for all $\rho' \in U$. Let $\chi(\rho') \in \mathcal{S}_{\tau,T}^0$, homogeneous, be such that $\text{supp } \chi \subset U$, and let $N \in \mathbb{N}$. There exist $C > 0$ and $\tau_0 > 0$ such that*

$$\|\text{Op}_T(\chi)w\|_{k,\tau}^2 + |\text{tr}(\text{Op}_T(\chi)w)|_{k-1,1/2,\tau}^2 \leq C (\|H \text{Op}_T(\chi)w\|_+^2 + \|w\|_{k,-N,\tau}^2 + |\text{tr}(w)|_{k-1,-N,\tau}^2),$$

for all $w \in \mathcal{S}(\overline{\mathbb{R}}_+^d)$ and $\tau \geq \tau_0$.

Observe that this lemma provides an estimate on all the traces at the boundary, up to microlocal remainder terms, which will be absorbed when patching all the microlocal estimates on the whole phase-space, by taking $\tau > 0$ sufficiently large.

Below, we consider operators that admit roots with non-negative imaginary parts. The covering condition imposed at the multi-interface \mathcal{I} on the set of operators (P_k, T_k^j, φ) is then a key element to obtain an estimation.

4.4 Interface quadratic forms

Definition 4.7. *For $w = (w_1, \dots, w_n) \in (\mathcal{S}(\overline{\mathbb{R}}_+^d))^n$, $N \in \mathbb{N}$ we define the following quadratic forms*

$$\mathcal{G}(w) := \sum_{s=1}^N \left(\sum_{k=1}^n A_k^s w_{k|_{x_d=0}}, \sum_{k=1}^n B_k^s w_{k|_{x_d=0}} \right)_\partial,$$

with $A_k^s = \text{Op}(a_k^s)$, and $B_k^s = \text{Op}(b_k^s)$. We say that \mathcal{G} is an interface quadratic form of type $(2m_1 - 1, \dots, 2m_n - 1, \sigma)$ if, for each $s \in \{1, \dots, N\}$ we have $a_k^s, b_k^s \in \mathcal{S}_{\tau,\text{cl}}^{2m_k-1, \sigma_k}$, for all $k \in \{1, \dots, n\}$, with $\sigma_1 + \dots + \sigma_n = 2\sigma$. Moreover, for $z = (z_1, \dots, z_n), \tilde{z} = (\tilde{z}_1, \dots, \tilde{z}_n) \in \mathbb{C}^{2m_1} \times \dots \times \mathbb{C}^{2m_n}$, where $z_k = (z_k^0, z_k^1, \dots, z_k^{2m_k-1})$ and $\tilde{z}_k = (\tilde{z}_k^0, \tilde{z}_k^1, \dots, \tilde{z}_k^{2m_k-1})$, we define

$$\Sigma_{\mathcal{G}}(\rho', z, \tilde{z}) = \sum_{s=1}^N \sum_{k=1}^n \Sigma_{a_k^s}(\rho', z_k) \overline{\sum_{k=1}^n \Sigma_{b_k^s}(\rho', \tilde{z}_k)},$$

where, for a symbol $a(\rho) = \sum_{j=0}^p a_j(\rho') \xi_d^j \in \mathcal{S}_{\tau,\text{cl}}^{p,s}$, we set

$$\Sigma_a(\rho', z) = \sum_{s=0}^p a_j(\rho') z_j, \quad \text{for } z = (z_0, \dots, z_p) \in \mathbb{C}^{p+1}.$$

Definition 4.8. Let W be an open conic set in $\mathbb{R}^{d-1} \times \mathbb{R}^{d-1} \times \mathbb{R}^+$ and let \mathcal{G} be an interface quadratic form of type $(2m_1 - 1, \dots, 2m_n - 1, \sigma)$ associated with the bilinear symbol $\Sigma_{\mathcal{G}}(\rho', z, \bar{z})$. We say that \mathcal{G} is positive definite in W if there exists $C > 0$ and $R > 0$ such that

$$\operatorname{Re} \Sigma_{\mathcal{G}}(\rho'_{|_{x_d=0}}, z, z) \geq C \sum_{k=1}^n \sum_{j=0}^{2m_k-1} \lambda_T^{2(2m_k-1-j+\sigma_k)} |z_k^j|^2,$$

for $z = (z_1, \dots, z_n) \in \mathbb{C}^{2m}$, $z_k = (z_k^0, \dots, z_k^{2m_k-1}) \in \mathbb{C}^{2m_k}$, $\tau \geq 0$, $\lambda_T \geq R$, $\rho'_{|_{x_d=0}} \in W$.

We have the following Gårding-type inequality. The proof follows [7].

Lemma 4.9. Let W be an open conic set in $\mathbb{R}^{d-1} \times \mathbb{R}^{d-1} \times \mathbb{R}^+$ and let \mathcal{G} be an interface quadratic form of type $(2m_1 - 1, \dots, 2m_n - 1, \sigma)$ that is positive definite in W . Let $\chi \in \mathcal{S}_{T,\tau}^0$ be a homogeneous symbol satisfying $\operatorname{supp} \chi|_{x_d=0} \subset W$ and let $M \in \mathbb{N}$. There exists $C > 0$, $C' > 0$ and $\tau_0 > 0$ such that

$$\operatorname{Re} \mathcal{G}(\operatorname{Op}_T(\chi)u) \geq C \sum_{k=1}^n |\operatorname{tr} \operatorname{Op}_T(\chi)u|_{2m_k-1, \sigma_k, \tau}^2 - C' \sum_{k=1}^n |\operatorname{tr} u_k|_{2m_k-1, \sigma_k-M, \tau}^2, \quad (4.5)$$

for $u = (u_1, \dots, u_n) \in (\mathcal{S}(\overline{\mathbb{R}}_+^d))^n$, $\tau \geq \tau_0$.

Proof. Using Definition 4.7, \mathcal{G} reads

$$\mathcal{G}(u) = \sum_{s=1}^N \left(\sum_{k=1}^n A_k^s u_k|_{x_d=0}, \sum_{k=1}^n B_k^s u_k|_{x_d=0} \right)_{\partial}, \quad \text{with } A_k^s, B_k^s \in \Psi_{\tau, \text{cl}}^{2m_k-1, \sigma_k}.$$

Using tangential pseudo-differential calculus, with classical symbols, there exist $a_{k,j}^s, b_{k,j}^s \in \mathcal{S}_{T,\tau, \text{cl}}^0$ such that

$$A_k^s = \sum_{j=0}^{2m_k-1} \operatorname{Op}_T(a_{k,j}^s) \operatorname{Op}_T(\lambda_T^{2m_k-1-j+\sigma_k}) D_d^j, \quad B_k^s = \sum_{j=0}^{2m_k-1} \operatorname{Op}_T(b_{k,j}^s) \operatorname{Op}_T(\lambda_T^{2m_k-1-j+\sigma_k}) D_d^j.$$

Denoting by $a \# b$, $a \in \mathcal{S}_{T,\tau, \text{cl}}^m$, $b \in \mathcal{S}_{T,\tau, \text{cl}}^{m'}$ the product of symbols, that is, for all $M \in \mathbb{N}$,

$$a \# b(\rho') = \sum_{|\alpha| < N} \frac{(-i)^{|\alpha|}}{\alpha!} \partial_{\xi'}^{\alpha} a(\rho') \partial_x^{\alpha} b(\rho') + r_M, \quad r_M \in \mathcal{S}_{T,\tau, \text{cl}}^{m+m'-M},$$

and a^* the adjoint symbol, that is, for all $M \in \mathbb{N}$,

$$a^*(\rho') = \sum_{|\alpha| < M} \frac{(-i)^{|\alpha|}}{\alpha!} \partial_{\xi}^{\alpha} \partial_x^{\alpha} \bar{a}(\rho') + r_M, \quad r_M \in \mathcal{S}_{T,\tau, \text{cl}}^{m-M},$$

the quadratic form \mathcal{G} can be written as

$$\begin{aligned} \mathcal{G}(u) &= \sum_{s=1}^N \left(\sum_{k=1}^n \sum_{j=0}^{2m_k-1} \operatorname{Op}_T(a_{k,j}^s) \operatorname{Op}_T(\lambda_T^{2m_k-1-j+\sigma_k}) D_d^j u_k|_{x_d=0}, \sum_{k=1}^n \sum_{j=0}^{2m_k-1} \operatorname{Op}_T(b_{k,j}^s) \operatorname{Op}_T(\lambda_T^{2m_k-1-j+\sigma_k}) D_d^j u_k|_{x_d=0} \right)_{\partial} \\ &= \sum_{k,k'=1}^n \sum_{j=0}^{2m_k-1} \sum_{j'=0}^{2m_{k'}-1} \left(\operatorname{Op}_T(g_{j,j}^{k',k'}) \operatorname{Op}_T(\lambda_T^{2m_k-1-j+\sigma_k}) D_d^j u_k|_{x_d=0}, \operatorname{Op}_T(\lambda_T^{2m_{k'}-1-j'+\sigma_{k'}}) D_d^{j'} u_{k'}|_{x_d=0} \right)_{\partial} \end{aligned}$$

where $g_{j,j}^{k,k'} \in \mathcal{S}_{T,\tau\text{cl}}^0$ is given by

$$g_{j,j'}^{k,k'} = \sum_{s=1}^N (b_{k,j}^s)^* \# a_{k',j'}^s.$$

We recast this equality into a system formalism. We then consider the following matrix symbol

$$G(\rho') = \begin{pmatrix} g^{1,1}(\rho') & \dots & g^{1,n}(\rho') \\ \vdots & & \vdots \\ g^{n,1}(\rho') & \dots & g^{n,n}(\rho') \end{pmatrix}, \quad g^{i,i'} = \left(g_{\ell,h}^{i,i'}(\rho') \right)_{\substack{0 \leq \ell \leq m_i - 1 \\ 0 \leq h \leq m_{i'} - 1}}.$$

It is then sufficient to follow the proof of Lemma 3.3 in [7]. \square

With the covering condition, we have the following positivity result, at the symbol level. In the following section, this positivity property will yield an actual estimate at the interface by means of Lemma 4.9.

Proposition 4.10. *Assume the covering condition of Definition 2.3 holds at $\rho'_0 \in \mathcal{L}^T(\mathcal{I})$. There exist a conical neighborhood U of ρ'_0 in $\bar{V}^+ \times \mathbb{R}^{d-1} \times \mathbb{R}^+$, $C > 0$ such that*

$$\begin{aligned} \sum_{j=1}^m \lambda_T^{2(\gamma_j-1/2)} \left| \sum_{k=1}^n \Sigma_{t_k^j}(\rho', z_k) \right|^2 + \sum_{k=1}^n \sum_{j=m+1}^{m'_k} \lambda_T^{2(m+m_k^- - j + 1/2)} |\Sigma_{e_{k,\varphi}^j}(\rho', z_k)|^2 \\ \geq C \sum_{k=1}^n \sum_{j=0}^{m_k-1} \lambda_T^{2(2m_k-1/2-j)} |z_k^j|^2, \end{aligned}$$

for all $\rho' \in U$, for all $z_k = (z_k^0, \dots, z_k^{2m_k-1}) \in \mathbb{C}^{m_k}$.

Proof. As the covering condition is fulfilled at $\rho'_0 \in \mathcal{L}^T(\mathcal{I})$, there exist an open conic neighborhood U of ρ'_0 in $\bar{V}^+ \times \mathbb{R}^{d-1} \times \mathbb{R}^+$ such that the rank condition (2.17) is satisfied at ρ' , for every $\rho' \in U$. Yet, consider the compact set $\mathcal{K} := \bar{U} \cap \mathbb{S}_{|\xi', \tau|=1}$, where $\mathbb{S}_{|\xi', \tau|=1} := \{(x, \xi', \tau) \in \mathbb{R}_+^d \times \mathbb{R}^{d-1} \times \mathbb{R}^+, |\xi'|^2 + \tau^2 = 1\}$. Let $\tilde{\rho}' \in \mathcal{K}$. in view of (2.17), we have that $M(\tilde{\rho}')$ is of maximal rank, that is $M(\tilde{\rho}') = 2m$. Taking $z = (z_1, \dots, z_n)$ with $z_k = (z_k^0, \dots, z_k^{2m_k-1}) \in \mathbb{C}^{2m_k}$, we have

$$\left({}^t M(\tilde{\rho}') z, {}^t M(\tilde{\rho}') z \right) \gtrsim \|z\|_{\mathbb{C}^{2m}}^2, \quad (4.6)$$

Recalling the form of M in (2.16), we have

$$\begin{aligned} \left(\overline{M(\tilde{\rho}')} {}^t M(\tilde{\rho}') z, z \right) &= \left| \sum_{k=1}^n {}^t M_k^1(\tilde{\rho}') z_k \right|^2 + \sum_{k=1}^n \left| {}^t M_k^2(\tilde{\rho}') z_k \right|^2 \\ &= \sum_{j=1}^m \left| \sum_{k=1}^n \Sigma_{t_k^j}(\tilde{\rho}', z_k) \right|^2 + \sum_{k=1}^n \sum_{j=m+1}^{m+m_k^-} |\Sigma_{e_{k,\varphi}^j}(\tilde{\rho}', z_k)|^2, \end{aligned}$$

and with (4.6), we have

$$\sum_{j=1}^m \left| \sum_{k=1}^n \Sigma_{t_k^j}(\tilde{\rho}', z_k) \right|^2 + \sum_{k=1}^n \sum_{j=m+1}^{m+m_k^-} |\Sigma_{e_{k,\varphi}^j}(\tilde{\rho}', z_k)|^2 \gtrsim \|z\|_{\mathbb{C}^{2m}}^2. \quad (4.7)$$

Then, by continuity, (4.7) is true in a neighborhood of $\tilde{\rho}'$, and with a compactness argument, is true for all $\rho' \in \mathcal{K}$. Yet, we define

$$H_{\lambda_T}(\rho') = (x, \lambda_T \xi', \lambda_T \tau),$$

and thus for every $\tilde{\rho}' \in \mathcal{K}$, we have $\tilde{\rho}' = H_{\lambda_T}^{-1} \rho'$ with $\rho' := H_{\lambda_T} \tilde{\rho}'$. We set $\tilde{z}_k^j = \lambda^{2m_k-1/2-j} z_k^j$, $\tilde{z}_k = (z_k^0, \dots, z_k^{2m_k-1})$ and $\tilde{z} = (\tilde{z}_1, \dots, \tilde{z}_n)$. By homogeneity of the symbols, (4.7) yields

$$\sum_{j=1}^m \left| \sum_{k=1}^n \Sigma_{t_{k,\varphi}^j}(\tilde{\rho}', \tilde{z}_k) \right|^2 + \sum_{k=1}^n \sum_{j=m+1}^{m+m_k^-} |\Sigma_{e_{k,\varphi}^j}(\tilde{\rho}', \tilde{z}_k)|^2 \gtrsim \|\tilde{z}\|_{\mathbb{C}^{2m}}^2,$$

which reads

$$\begin{aligned} \sum_{j=1}^m \left| \sum_{k=1}^n \lambda_T^{2m_k+1/2-\beta_k^j} \Sigma_{t_{k,\varphi}^j}(\rho', z_k) \right|^2 + \sum_{k=1}^n \sum_{j=m+1}^{m+m_k^-} |\lambda_T^{m+m_k^-+1/2-j} \Sigma_{e_{k,\varphi}^j}(\tilde{\rho}', z_k)|^2 \\ \gtrsim \sum_{k=1}^n \sum_{j=0}^{2m_k-1} |\lambda^{2m_k-1/2-j} z_k^j|^2. \end{aligned}$$

Using assumption (1.2), this yields the result. \square

4.5 Estimate with the covering condition

The following proposition shows how the covering condition allows one to estimate all the traces at the interface. The estimate is microlocal near a point where the covering condition holds.

Proposition 4.11. *Let $\rho'_0 = (x_0, \xi_0, \tau_0)$, $x_0 \in \mathcal{I}$, such that the covering condition of Definition 2.3 holds at ρ'_0 . Then, there exists a conic neighborhood \mathcal{V} of ρ'_0 in $\bar{V}^+ \times \mathbb{R}^{d-1} \times \mathbb{R}^+$ such that for $\chi \in \mathcal{S}_{T,\tau}^0$ homogeneous in (ξ', τ) with $\text{supp } \chi \subset \mathcal{V}$, there exist $C > 0$ and $\tau_1 > 0$ such that*

$$\begin{aligned} C \sum_{k=1}^n |\text{tr Op}_T(\chi) v_k|_{2m_k-1,1/2,\tau}^2 \leq \sum_{j=1}^m \left| \sum_{k=1}^n T_{k,\varphi}^j v_k|_{x_d=0} \right|_{\gamma_j-1/2,\tau}^2 + \sum_{k=1}^n \|P_{k,\varphi} v_k\|_+^2 \\ + \sum_{k=1}^n (\|v_k\|_{2m_k,-1,\tau}^2 + |\text{tr } v_k|_{2m_k-1,-1/2,\tau}^2), \quad (4.8) \end{aligned}$$

for all $\tau \geq \tau_1$, $v = (v_1, \dots, v_n) \in (\mathcal{S}(\bar{\mathbb{R}}_+^d))^n$.

Proof. Consider the factorization described in Section 2.5

$$p_{k,\varphi}(\rho', \xi_d) = p_{k,\varphi}^-(\rho', \xi_d) \kappa(\rho', \xi_d), \quad (4.9)$$

for ρ' in a conic neighborhood \mathcal{V}_0 of ρ'_0 , with $p_{k,\varphi}^-$, $\kappa_{k,\varphi}$ polynomials with homogeneous coefficients, $p_{k,\varphi}^-$ being monic. Using Proposition 4.10, there exists a conic neighborhood \mathcal{V}_1 of ρ'_0 , $\mathcal{V}_1 \subset \mathcal{V}_0$, such that

$$\begin{aligned} \sum_{j=1}^m \lambda_T^{2(\gamma_j-1/2)} \left| \sum_{k=1}^n \Sigma_{t_{k,\varphi}^j}(\rho', z_k) \right|^2 + \sum_{k=1}^n \sum_{j=m+1}^{m+m_k^-} \lambda_T^{2(m+m_k^- - j + 1/2)} |\Sigma_{e_{k,\varphi}^j}(\rho', z_k)|^2 \\ \geq C \sum_{k=1}^n \sum_{j=0}^{2m_k-1} \lambda_T^{2(2m_k-1/2-j)} |z_k^j|^2, \quad (4.10) \end{aligned}$$

holds for all $\rho' \in \mathcal{V}_1$ and for all $z = (z_1, \dots, z_n) \in \mathbb{C}^{2m}$, with $z_k = (z_k^0, \dots, z_k^{2m_k-1}) \in \mathbb{C}^{2m_k}$. Now we consider a conic neighborhood \mathcal{V} of ρ'_0 satisfying $\mathcal{V} \subset \mathcal{V}_1$, and $\chi \in \mathcal{S}_{T,\tau}^0$ homogeneous such that

supp $\chi \subset \mathcal{V}$, and $\tilde{\chi} \in \mathcal{S}_{T,\tau}^0$ homogeneous such that supp $\tilde{\chi} \subset \mathcal{V}_1$, and $\tilde{\chi} = 1$ in a neighborhood of \mathcal{V} . Consider a smooth extension $\tilde{p}_{k,\varphi}^-$ outside \mathcal{V}_0 . Note that by symbolic calculus, we have $\text{Op}_T(\chi)P_{k,\varphi} = \text{Op}(\tilde{p}_{k,\varphi}^-) \text{Op}_T(\chi) \text{Op}(\tilde{\chi}\kappa_{k,\varphi}) + R_k$, and $R_k \in \Psi_{\tau,\text{cl}}^{2m_k,-1}$. Take also $v = (v_1, \dots, v_n) \in (\mathcal{S}(\overline{\mathbb{R}}_+^d))^n$. By definition, $p_{k,\varphi}^-$ has only roots with negative imaginary parts. Thus we can apply Lemma 4.6 to the function $w_k := \text{Op}(\tilde{\chi}\kappa_{k,\varphi})v_k \in \mathcal{S}(\overline{\mathbb{R}}_+^d)$, and we obtain, for all $k \in \{1, \dots, n\}$, for any $N \in \mathbb{N}$,

$$\|\text{Op}_T(\chi)w_k\|_{m_k^-, \tau}^2 + |\text{tr}(\text{Op}_T(\chi)w_k)|_{m_k^- - 1, 1/2, \tau} \quad (4.11)$$

$$\begin{aligned} &\lesssim \|\text{Op}(p_{k,\varphi}^-) \text{Op}_T(\chi)w_k\|_+^2 + \|w_k\|_{m_k^-, -N, \tau}^2 + |\text{tr} w_k|_{m_k^- - 1, -N, \tau}^2 \\ &\lesssim \|P_{k,\varphi}v_k\|_+^2 + \|v_k\|_{2m_k, -1, \tau}^2 + |\text{tr} v_k|_{2m_k - 1, -N, \tau}^2. \end{aligned} \quad (4.12)$$

By definition, we have $|\text{tr}(\text{Op}_T(\chi)w_k)|_{m_k^- - 1, 1/2, \tau}^2 = \sum_{j=0}^{m_k^- - 1} |D_d^j \text{Op}_T(\chi)w_k|_{m_k^- - 1/2 - j, \tau}^2$, thus (4.12) gives

$$\sum_{j=0}^{m_k^- - 1} |D_d^j \text{Op}_T(\chi)w_k|_{m_k^- - 1/2 - j, \tau}^2 \lesssim \|P_{k,\varphi}v_k\|_+^2 + \|v_k\|_{2m_k, -1, \tau}^2 + |\text{tr} v_k|_{2m_k - 1, -N, \tau}^2. \quad (4.13)$$

Yet, we recall that for $j \in \{0, \dots, m_k^- - 1\}$, from (2.15), we defined $e_k^{j+m+1}(\rho', \xi_d) = \xi_d^j \kappa_{k,\varphi}(\rho', \xi_d)$, for $\rho' \in \mathcal{V}_0$. Hence, by symbolic calculus, for $j \in \{0, \dots, m_k^- - 1\}$

$$D_d^j \text{Op}_T(\chi) \text{Op}(\tilde{\chi}\kappa_{k,\varphi}) = \text{Op}(\tilde{\chi}e_k^{j+m+1}) \text{Op}_T(\chi) + R'_k,$$

where the remainder $R'_k \in \Psi_{\tau}^{2m_k - m_k^- + j, -1}$. From (4.13), this yields

$$\sum_{k=1}^n \sum_{m+1}^{m'_k} |\text{Op}(\tilde{\chi}e_k^j) \text{Op}_T(\chi)v_k|_{m_k^- - 1/2 - j, \tau}^2 \lesssim \sum_{k=1}^n \|P_{k,\varphi}v_k\|_+^2 + \|v_k\|_{2m_k, -1, \tau}^2 + |\text{tr} v_k|_{2m_k - 1, -1/2, \tau}^2. \quad (4.14)$$

From (4.10), as $\tilde{\chi} = 1$ on \mathcal{V} , we have for all $\rho' \in \mathcal{V}$,

$$\begin{aligned} &\sum_{j=1}^m \lambda_T^{2(\gamma_j - 1/2)} \left| \sum_{k=1}^n \sum_{t_{k,\varphi}^j} |\rho', z_k|^2 + \sum_{k=1}^n \sum_{j=m+1}^{m'_k} \lambda_T^{2(m+m_k^- - j + 1/2)} |\tilde{\chi}(\rho') \Sigma_{e_{k,\varphi}^j}(\rho', z_k)|^2 \right. \\ &\quad \left. \geq C \sum_{k=1}^n \sum_{j=0}^{2m_k - 1} \lambda_T^{2(2m_k - 1/2 - j)} |z_k^j|^2. \end{aligned} \quad (4.15)$$

Yet, consider the following quadratic form, for $u = (u_1, \dots, u_n) \in (\mathcal{S}(\overline{\mathbb{R}}_+^d))^n$,

$$\mathcal{G}(u) = \sum_{j=1}^m \left| \sum_{k=1}^n T_{k,\varphi}^j u_k|_{x_d=0} \right|_{\gamma_j - 1/2, \tau}^2 + \sum_{k=1}^n \sum_{j=m+1}^{m'_k} |\text{Op}(\tilde{\chi}e_k^j)u_k|_{x_d=0}^2|_{m+m_k^- + 1/2 - j},$$

which symbol is given by

$$\begin{aligned} \Sigma_{\mathcal{G}}(\rho', z, \tilde{z}) &= \sum_{j=1}^m \lambda_T^{2(\gamma_j - 1/2)} \left(\sum_{k=1}^n \Sigma_{t_{k,\varphi}^j}(\rho', z_k) \right) \overline{\left(\sum_{k=1}^n \Sigma_{t_{k,\varphi}^j}(\rho', \tilde{z}_k) \right)} \\ &\quad + \sum_{k=1}^n \sum_{j=m+1}^{m+m_k^-} |\tilde{\chi}(\rho')|^2 \lambda_T^{2(m+m_k^- + 1/2 - j)} \Sigma_{e_{k,\varphi}^j}(\rho', z_k) \overline{\Sigma_{e_{k,\varphi}^j}(\rho', \tilde{z}_k)}, \end{aligned}$$

with $z = (z_1, \dots, z_n)$, where $z_k \in \mathbb{C}^{2m_k}$. With (4.15), and the Gårding inequality of Lemma 4.9, for $N \in \mathbb{N}$, there exists $\tau_0, C, C' > 0$ such that

$$\mathcal{G}(\text{Op}_T(\chi)v) \geq C \sum_{k=1}^n |\text{tr}(\text{Op}(\chi)v_k)|_{2m_k-1,1/2,\tau}^2 - C' \sum_{k=1}^n |\text{tr} v_k|_{2m_k-1,-N,\tau}^2, \quad (4.16)$$

for $\tau \geq \tau_0$. Hence, inserting (4.16) in (4.14), we obtain

$$\begin{aligned} \sum_{k=1}^n |\text{tr}(\text{Op}(\chi)v_k)|_{2m_k-1,1/2,\tau}^2 &\lesssim \sum_{j=1}^m \left| \sum_{k=1}^n T_{k,\varphi}^j \text{Op}_T(\chi)v_k|_{x_d=0} \right|_{\gamma_j-1/2,\tau}^2 \\ &\quad + \sum_{k=1}^n (\|P_{k,\varphi} v_k\|_+^2 + \|v_k\|_{2m_k,-1,\tau}^2 + |\text{tr} v_k|_{2m_k-1,-1/2,\tau}^2). \end{aligned} \quad (4.17)$$

It remains to see that $T_{k,\varphi}^j \text{Op}_T(\chi) = \text{Op}_T(\chi)T_{k,\varphi}^j + [T_{k,\varphi}^j, \text{Op}_T(\chi)]$ to obtain

$$\sum_{j=1}^m \left| \sum_{k=1}^n T_{k,\varphi}^j \text{Op}_T(\chi)v_k|_{x_d=0} \right|_{\gamma_j-1/2,\tau}^2 \lesssim \sum_{j=1}^m \left| \sum_{k=1}^n T_{k,\varphi}^j v_k|_{x_d=0} \right|_{\gamma_j-1/2,\tau}^2 + \sum_{j=1}^m \sum_{k=1}^n |\text{tr} v_k|_{\beta_k^j, 2m_k-\beta_k^j-3/2,\tau}^2.$$

Using the definition of the norms on the traces (4.3), we have

$$\begin{aligned} |\text{tr} v_k|_{\beta_k^j, 2m_k-\beta_k^j-3/2,\tau}^2 &= \sum_{\ell=0}^{\beta_k^j} |D^\ell v_k|_{x_d=0}|_{2m_k-\ell-3/2,\tau}^2 \leq \sum_{\ell=0}^{2m_k-1} |D^\ell v_k|_{x_d=0}|_{2m_k-\ell-3/2,\tau}^2 \\ &= |\text{tr} v_k|_{2m_k-1,-1/2,\tau}^2, \end{aligned}$$

and the proof is complete. \square

4.6 Microlocal estimate with operators satisfying both sub-ellipticity and covering condition

Using both the covering condition (by means of Proposition 4.11) and the sub-ellipticity condition (by means of Lemma 4.5), we are ready to prove the following microlocal Carleman estimate, in a conic neighborhood of a point in $\mathcal{L}^T(\mathcal{I})$.

Theorem 4.12. *Let $x_0 \in \mathcal{I} \cap \bar{\mathcal{V}}$. Assume that (P_k, φ_k) satisfies the sub-ellipticity condition in a neighborhood of x_0 in $\bar{\mathcal{V}}^+$, and that (T_k^j, φ) covers (P_k, φ) at $\rho' \in \mathcal{L}_{x_0}^T(\mathcal{I})$. Then, there exists \mathcal{V} a conic neighborhood of ρ' in $\bar{\mathcal{V}}^+ \times \mathbb{R}^{d-1} \times \mathbb{R}^+$ such that for $\chi \in \mathcal{S}_{T,\tau}^0$ homogeneous of degree 0 satisfying $\text{supp } \chi \subset \mathcal{V}$, there exist $C, \tau_0 > 0$ such that*

$$\begin{aligned} \tau^{-1} \sum_{k=1}^n \|\text{Op}_T(\chi)v_k\|_{2m_k,\tau}^2 + \sum_{k=1}^n |\text{tr}(\text{Op}(\chi)v)|_{2m_k-1,1/2,\tau}^2 &\leq C \left(\sum_{k=1}^n \|P_{k,\varphi} v_k\|_+^2 \right. \\ &\quad \left. + \sum_{j=1}^m \left| \sum_{k=1}^n T_{k,\varphi}^j v_k|_{x_d=0} \right|_{\gamma_j-1/2,\tau}^2 + \sum_{k=1}^n \|v_k\|_{2m_k,-1,\tau}^2 + \sum_{k=1}^n |\text{tr} v_k|_{2m_k-1,-1/2,\tau}^2 \right), \end{aligned} \quad (4.18)$$

for $\tau \geq \tau_0$, for $v = (v_1, \dots, v_n) \in (\mathcal{S}(\bar{\mathbb{R}}_+^d))^n$.

Proof. Consider a neighborhood U of x_0 in \bar{V}^+ such that the sub-ellipticity condition holds in U . First we write

$$P_{k,\varphi} = P_{k,2} + iP_{k,1}, \quad \text{with } P_{k,2} = \frac{1}{2}(P_{k,2} + P_{k,2}^*), \quad P_{k,1} = \frac{1}{2i}(P_{k,2} - P_{k,2}^*). \quad (4.19)$$

We shall denote by $p_{k,\varphi} \in \mathcal{S}_\tau^{m_k,0}$, $p_{k,2} \in \mathcal{S}_\tau^{m_k,0}$, $p_{k,1} \in \mathcal{S}_\tau^{m_k-1,1}$ their principal symbols, respectively. Let \mathcal{U} be a conical neighborhood of ρ'_0 given by Proposition 4.11. We have from (4.19)

$$\begin{aligned} \|v_k\|_{2m_k,-1,\tau}^2 + \|P_{k,\varphi}v_k\|_+^2 &\gtrsim \|\text{Op}_T(\chi)v_k\|_{2m_k,-1,\tau}^2 + \|P_{k,\varphi}\text{Op}_T(\chi)v_k\|_+^2 \\ &\gtrsim \|\text{Op}(p_{k,2})\text{Op}_T(\chi)v_k\|_+^2 + \|\text{Op}(p_{k,1})\text{Op}_T(\chi)v_k\|_+^2 + Q_{p_{k,2},p_{k,1}}(\text{Op}_T(\chi)v_k) \\ &\gtrsim \tau^{-1}\|\text{Op}(p_{k,2})\text{Op}_T(\chi)v_k\|_+^2 + \tau^{-1}\|\text{Op}(p_{k,1})\text{Op}_T(\chi)v_k\|_+^2 \\ &\quad + Q_{p_{k,2},p_{k,1}}(\text{Op}_T(\chi)v_k), \end{aligned} \quad (4.20)$$

where $Q_{p_{k,2},p_{k,1}}$ is the quadratic form defined in (4.4). We have from Lemma 4.5, as the sub-ellipticity condition holds,

$$\begin{aligned} C\tau^{-1}\|\text{Op}_T(\chi)v_k\|_{2m_k,\tau}^2 &\leq C'\tau^{-1}(\|\text{Op}(p_{k,2})\text{Op}_T(\chi)v_k\|_+^2 + \|\text{Op}(p_{k,1})\text{Op}_T(\chi)v_k\|_+^2 \\ &\quad + |\text{tr}\text{Op}_T(\chi)v_k|_{2m_k-1,1/2,\tau}^2) + (Q_{p_{k,2},p_{k,1}}(\text{Op}_T(\chi)v_k) - \text{Re}\mathcal{B}_{p_{k,2},p_{k,1}}(\text{Op}_T(\chi)v_k)), \end{aligned} \quad (4.21)$$

where $\mathcal{B}_{p_{k,2},p_{k,1}}$ satisfies

$$\mathcal{B}_{p_{k,2},p_{k,1}}(\text{Op}_T(\chi)v_k) \leq C|\text{tr}(\text{Op}_T(\chi)v_k)|_{2m_k-1,1/2,\tau}^2.$$

From Proposition 4.11, with the covering condition, we have

$$\begin{aligned} C\sum_{k=1}^n |\text{tr}\text{Op}_T(\chi)v_k|_{2m_k-1,1/2,\tau}^2 &\leq \sum_{j=1}^m \left| \sum_{k=1}^n T_{k,\varphi}^j v_k|_{x_d=0} \right|_{\gamma_j-1/2,\tau}^2 + \sum_{k=1}^n \|P_{k,\varphi}v_k\|_+^2 \\ &\quad + \sum_{k=1}^n (\|v_k\|_{2m_k,-1,\tau}^2 + |\text{tr}v_k|_{2m_k-1,-1/2,\tau}^2). \end{aligned} \quad (4.22)$$

Combining estimates (4.21) and (4.22), we obtain, with C' taken sufficiently large

$$\begin{aligned} &C\tau^{-1}\sum_{k=1}^n \|\text{Op}_T(\chi)v_k\|_{2m_k,\tau}^2 + C\sum_{k=1}^n |\text{tr}\text{Op}_T(\chi)v_k|_{2m_k-1,1/2,\tau}^2 \\ &\leq C'\left(\tau^{-1}\sum_{k=1}^n \|\text{Op}(p_{k,2})\text{Op}_T(\chi)v_k\|_+^2 + \tau^{-1}\sum_{k=1}^n \|\text{Op}(p_{k,1})\text{Op}_T(\chi)v_k\|_+^2 + \sum_{j=1}^m \left| \sum_{k=1}^n T_{k,\varphi}^j v_k|_{x_d=0} \right|_{\gamma_j-1/2,\tau}^2 \right. \\ &\quad \left. + \sum_{k=1}^n \|P_{k,\varphi}v_k\|_+^2 + \sum_{k=1}^n (\|v_k\|_{2m_k,-1,\tau}^2 + |\text{tr}v_k|_{2m_k-1,-1/2,\tau}^2) \right) + \sum_{k=1}^n Q_{p_{k,2},p_{k,1}}(\text{Op}_T(\chi)v_k). \end{aligned} \quad (4.23)$$

It remains to use (4.20) to obtain the sought result. \square

4.7 Proof of the main result.

Let $x_0 \in \mathcal{I}$ and \bar{V} be like in Theorem 4.12. By assumption the covering condition holds for all $(x_0, Y, \nu_1, \dots, \nu_n, \tau) \in \mathcal{L}_{x_0}^T(\mathcal{I})$. Using the local coordinates introduced in Section 2, we can only consider $\rho = (x, \xi', \xi_d, \tau)$, with $(x, \xi', \tau) \in \mathbb{S}_{|\xi', \tau|=1}$. According to Theorem 4.12, for all $\rho' = (x, \xi', \tau)$, there

exists a conic neighborhood $\mathcal{U}_{\rho'} = O_{\rho'} \times C_{\rho'}$ of ρ' in $\bar{V} \times \mathbb{R}^{d-1} \times \mathbb{R}^+$ such that the Carleman estimate (4.18) holds in $\mathcal{U}_{\rho'}$. By a compactness argument, we can extract from the family of the $\mathcal{U}_{\rho'}$ a finite number of conical subsets $\mathcal{U}_j := O_j \times C_j$, $j \in J$ such that $\mathbb{S}_{|\xi', \tau|=1} \subset \cup_{j \in J} C_j$. First we set $W = \cap_{j \in J} O_j$ and $\mathcal{V}_j = W \times C_j$. We construct a partition of unity $(\chi_j)_{j \in J}$, $\chi_j \in \mathcal{S}_{T, \tau}^0$, homogeneous of degree 0 in $(\xi', \tau) \geq C > 0$ such that

$$\sum_{j \in J} \chi_j(\rho') = 1, \text{ for } (\xi', \tau) \geq C > 0, \quad \text{supp}(\chi_j) \subset \mathcal{V}_j.$$

Applying Theorem 4.12, we have

$$\begin{aligned} \tau^{-1} \sum_{j \in J} \sum_{k=1}^n \|\text{Op}_T(\chi_j)v_k\|_{2m_k\tau}^2 + \sum_{j \in J} \sum_{k=1}^n |\text{tr}(\text{Op}(\chi_j)v_k)|_{2m_k-1,1/2,\tau}^2 \leq C \left(\sum_{k=1}^n \|P_{k,\varphi}v_k\|_+^2 \right. \\ \left. + \sum_{j=1}^m \left| \sum_{k=1}^n T_k^j v_k|_{x_d=0} \right|_{\gamma_j-1/2,\tau}^2 + \sum_{k=1}^n \|v_k\|_{2m_k,-1,\tau}^2 + \sum_{k=1}^n |\text{tr} v_k|_{2m_k-1,-1/2,\tau}^2 \right), \end{aligned} \quad (4.24)$$

for all $v_k \in \bar{C}_0^{+\infty}(W)$, $k = 1, \dots, n$. From the fact that $\tilde{\chi} := 1 - \sum_{j \in J} \chi_j$ belongs to $\mathcal{S}_{T, \tau}^{-N}$ in $W \times \mathbb{R}^{d-1} \times \mathbb{R}^+$, for all $N \in \mathbb{N}$, we have that

$$\begin{aligned} \tau^{-1} \sum_{k=1}^n \|v_k\|_{2m_k\tau}^2 + \sum_{k=1}^n |\text{tr}(v_k)|_{2m_k-1,1/2,\tau}^2 \leq \tau^{-1} \sum_{j \in J} \sum_{k=1}^n \|\text{Op}_T(\chi_j)v_k\|_{2m_k\tau}^2 \\ + \sum_{j \in J} \sum_{k=1}^n |\text{tr}(\text{Op}(\chi_j)v_k)|_{2m_k-1,1/2,\tau}^2 + \sum_{k=1}^n \|v_k\|_{2m_k-1,1/2-N}^2 + \sum_{k=1}^n |\text{tr}(v_k)|_{2m_k-1,1/2-N,\tau}^2, \end{aligned} \quad (4.25)$$

as $\text{supp}(w_k) \subset W$. Combining (4.24) and (4.25), we obtain by taking τ large,

$$\begin{aligned} \tau^{-1} \sum_{k=1}^n \|v_k\|_{2m_k-1,1/2,\tau}^2 + \sum_{k=1}^n |\text{tr}(v_k)|_{2m_k-1,1/2,\tau}^2 \leq C \left(\sum_{k=1}^n \|P_{k,\varphi}v_k\|_+^2 \right. \\ \left. + \sum_{j=1}^m \left| \sum_{k=1}^n T_k^j v_k|_{x_d=0} \right|_{\gamma_j-1/2,\tau}^2 \right). \end{aligned}$$

Going back with the original variable $u_k = e^{\tau\varphi_k}v_k$ yields the result, taking into account of the change of variable described in (2.1). With the notation introduced there, the open set \tilde{U} can be chosen as $\tilde{U} = \cap_{k=1}^n \phi_k^{-1}(W)$. \square

5 Applications to control theory for the transmission problem

In this section, we shall place ourselves in the following setting. We consider p smooth compact Riemannian manifolds (Ω_k, g_k) of dimension $d \geq 2$, $k = 1, \dots, p$, with boundary $\partial\Omega_k$. We set $\Omega = \cup_{k=1}^p \Omega_k$. We assume that Ω is connected and that $\partial\Omega_k$ has n_k connected component, with $n_k \geq 1$. We further assume that the manifolds shares some of the connected component of their boundary with others. More precisely, we shall denote by \mathcal{I}_ℓ , $\ell \in \{1, \dots, L\}$ the set of interfaces that are shared by at least two manifolds, and we shall denote by \mathcal{B}_k , $k \in \{1, \dots, K\}$ the remaining connected components of the boundaries. As in Section 3, we shall consider the Laplace-Beltrami operator on each Ω_k and a transmission problem as in (3.1) at each interface \mathcal{I}_ℓ , $\ell \in \{1, \dots, L\}$. The case $d = 1$, corresponds to the case of elliptic problems on a connected graph. However, as we prove our Carleman estimates only for $d \geq 2$, we do not consider the case $d = 1$ is what follows. For such issues, we refer to [4, 13, 19, 30] and the references therein.

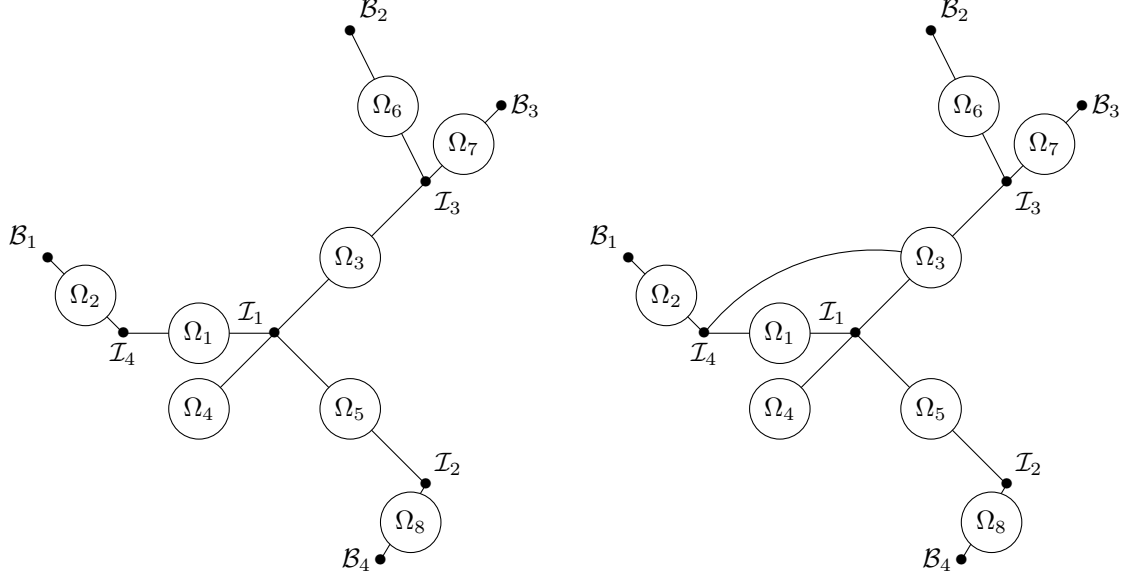

Figure 3: We recast geometrical configurations under a graph form: the edges represent the manifolds Ω_k , and the vertices the interfaces \mathcal{I}_ℓ , or the boundaries \mathcal{B}_k .

5.1 Observable domains

We propose a method to describe the global geometrical configuration we can deal with. Indeed, due to the discussion made at the end of Section 3.1, locally, we have to observe any n -interface from at least $(n-1)$ -sides.

Let ω be an open subset of Ω . We shall write $\omega_\ell = \Omega_\ell \cap \omega$, and $\mathcal{L} = \{\ell \in \{1, \dots, p\}, \omega_\ell \neq \emptyset\}$. For $k \in \{1, \dots, p\}$, we define the following map

$$\mathcal{N}_k : \mathcal{I}_\ell \mapsto \begin{cases} 1 & \text{if } \Omega_k \cap \mathcal{I}_\ell \neq \emptyset \\ 0 & \text{otherwise.} \end{cases} \quad (5.1)$$

In other words, this map returns 1 if \mathcal{I}_ℓ is an interface shared by Ω_k . We set $\mathcal{V}^\ell := \{k \in \{1, \dots, p\}, \mathcal{N}_k(\mathcal{I}_\ell) = 1\}$, that is, the set of manifolds that share the interface \mathcal{I}_ℓ . Conversely, we define $\mathcal{W}_k := \{\ell \in \{1, \dots, L\}, \mathcal{N}_k(\mathcal{I}_\ell) = 1\}$, that is, the set of indices of interfaces that are shared by the manifold Ω_k .

We consider the following construction, with $\mathcal{O}_0 := \mathcal{L}$,

$$\mathcal{O}_{j+1} = \mathcal{O}_j \cup \left(\bigcup_{\ell=1}^L \mathcal{V}_j^\ell \right), \quad \mathcal{V}_j^\ell := \begin{cases} \tilde{\mathcal{V}}_j^\ell & \text{if } \text{Card } \tilde{\mathcal{V}}_j^\ell \leq 1 \\ \emptyset & \text{otherwise,} \end{cases} \quad \text{and where } \tilde{\mathcal{V}}_j^\ell = \mathcal{V}^\ell \setminus \mathcal{O}_j. \quad (5.2)$$

In other words, at each step, for all $\ell \in \{1, \dots, L\}$, we count the number of sides of \mathcal{I}_ℓ that belongs to \mathcal{O}_j . If this number corresponds to an observation from at least $(n-1)$ -sides, we add to \mathcal{O}_j the remaining side. Observe that $\text{Card } \mathcal{V}_j^\ell \leq 1$ at each step. Note also that if $\mathcal{O}_j = \mathcal{O}_{j+1}$ for some j , then $\mathcal{O}_{j'} = \mathcal{O}_j$, for all $j' \geq j$. With this construction, we have the following definition.

Definition 5.1. *We say that (Ω, ω) is observable, if there exists $j_0 \in \mathbb{N}$ such that $\mathcal{O}_{j_0} = \{1, \dots, p\}$ in the iterated construction described in (5.2).*

In the example given on the left-hand-side of Figure 3, assume $\mathcal{L} = \{2, 4, 5, 6\}$. Then

1. $\mathcal{O}_0 = \mathcal{L}, \cup_{\ell=1}^L \tilde{\mathcal{V}}_0^\ell = \{1, 3, 7, 8\}, \cup_{\ell=1}^L \mathcal{V}_0^\ell = \{1, 8\}$
2. $\mathcal{O}_1 = \{1, 2, 4, 5, 6, 8\}, \cup_{\ell=1}^L \tilde{\mathcal{V}}_1^\ell = \{3, 7\}, \cup_{\ell=1}^L \mathcal{V}_1^\ell = \{3\}$
3. $\mathcal{O}_2 = \{1, 2, 3, 4, 5, 6, 8\}, \cup_{\ell=1}^L \tilde{\mathcal{V}}_2^\ell = \{7\}, \cup_{\ell=1}^L \mathcal{V}_2^\ell = \{7\}$
4. $\mathcal{O}_3 = \{1, 2, 3, 4, 5, 6, 7, 8\}$.

As a result, according to Definition 5.1, we have that (Ω, ω) is observable. In the example given on the right hand side of Figure 3, assume $\mathcal{L} = \{2, 4, 5, 6\}$. Then

1. $\mathcal{O}_0 = \mathcal{L}, \cup_{\ell=1}^L \tilde{\mathcal{V}}_0^\ell = \{1, 3, 7, 8\}, \cup_{\ell=1}^L \mathcal{V}_0^\ell = \{8\}$
2. $\mathcal{O}_1 = \{2, 4, 5, 6, 8\}, \cup_{\ell=1}^L \tilde{\mathcal{V}}_1^\ell = \{3, 4, 7\}, \cup_{\ell=1}^L \mathcal{V}_1^\ell = \emptyset$
3. $\mathcal{O}_1 = \mathcal{O}_2 \neq \{1, \dots, 8\}$.

Hence, (Ω, ω) is not observable in this particular case.

5.2 Setting

Consider $Z := (0, X_0) \times \Omega$, where $X_0 > 0$ (resp. $Z_k := (0, X_0) \times \Omega_k$). Let $\alpha \in (0, X_0/2)$, and define $Y := (\alpha, X_0 - \alpha) \times \Omega$ (resp. $Y_k := (\alpha, X_0 - \alpha) \times \Omega_k$). For $z = (z_0, x) \in Z$ (resp. Y), we shall mean $z_0 \in (0, X_0)$ (resp. $z_0 \in (\alpha, X_0 - \alpha)$) and $x \in \Omega$. For $\ell \in \{1, \dots, L\}$ (see the beginning of this section for the notation), we also set $S_\ell = (0, X_0) \times \mathcal{I}_\ell$ and $S_\ell^\alpha = (\alpha, X_0 - \alpha) \times \mathcal{I}_\ell$. For $k \in \{1, \dots, K\}$, we consider $R_k = (0, X_0) \times \mathcal{B}_k$ and $R_k^\alpha = (\alpha, X_0 - \alpha) \times \mathcal{B}_k$. We finally set $\mathfrak{W}_k = \{i \in \{1, \dots, p\}, \Omega_i \cap \mathcal{B}_k \neq \emptyset\}$, that is the set of the indices of the manifold that has \mathcal{B}_k as a boundary. We consider the following transmission problem for a general domain Ω , with Dirichlet boundary condition:

$$\begin{cases} -\partial_{x_0}^2 u_k - \Delta_{g_k} u_k = f_k & \text{in } Z_k, \quad k = 1, \dots, p \\ u_i|_{S_\ell} = u_j|_{S_\ell} & \text{on } S_\ell, \quad \forall \ell \in \{1, \dots, L\}, \quad \forall i, j \in \mathcal{V}^\ell, \\ \sum_{k \in \mathcal{V}^\ell} \partial_{\nu_k} u_k|_{S_\ell} = 0 & \text{on } S_\ell, \quad \forall \ell \in \{1, \dots, L\}, \\ u_i|_{\mathcal{B}_j} = 0 & \text{on } R_k, \quad \forall j \in \{1, \dots, K\}, \quad i \in \mathfrak{W}_j, \end{cases} \quad (5.3)$$

where Δ_{g_k} stands for the Laplace-Beltrami operator on Ω_k . Other boundary conditions can also be considered satisfying the Lopatinskii condition. For the sake of simplicity, we only consider Dirichlet boundary conditions here. We define $u(x) = u_k(x)$, and $f(x) = f_k(x)$ if $x \in Z_k$. Similarly, for v defined on Ω (resp. Z or Y), we set v_k on Ω_k (resp. Z_k or Y_k) as $v_k(x) = v(x)$ for $x \in \Omega_k$ (resp. $v_k(s, x) = v(s, x)$ for $(s, x) \in Z_k$ or Y_k). We also define the Sobolev spaces, for $m \in \mathbb{N}$,

$$H^m(\Omega) = \{u, u_k \in H^m(\Omega_k)\},$$

and on Z (resp. Y), we define

$$H^m(Z) = \{u(x) := u_k(x), x \in Z_k, u_k \in H^m(Z_k)\}, \quad H^m(Y) = \{u(x) := u_k(x), x \in Y_k, u_k \in H^m(Y_k)\}.$$

5.3 An interpolation inequality

By standard arguments, [28], [25],[26], local Carleman estimates are used to prove interpolation inequalities.

Theorem 5.2. *Let ω be a subset of Ω such that (Ω, ω) is observable, in the sense of Definition 5.1. There exist $C > 0$ and $\delta > 0$ such that*

$$\|u\|_{H^1(Y)} \leq C \|u\|_{H^1(Z)}^{1-\delta} \left(\|f\|_{L^2(Z)} + |u|_{x_0=0}|_{H^1(\omega)} + |\partial_{x_0} u|_{x_0=0}|_{L^2(\omega)} \right)^\delta, \quad (5.4)$$

for all $u \in H^1(Y)$ solution of (5.3), with $f \in L^2(Z)$.

It is classical that the proof of Theorem 5.2 can be reduced to proving the following lemma, which is a local version of Theorem 5.2, in a neighborhood of an interface. For $\ell \in \{1, \dots, L\}$ and $k \in \mathcal{V}^\ell$, define $Y_k^\eta = \{x \in Y_k, d(x, \cup_{\ell=1}^L S_\ell^\alpha \cup_{k=1}^K R_k^\alpha) > \eta\}$. Here, d denotes the Riemannian distance.

Lemma 5.3. *Let $\ell \in \{1, \dots, L\}$. Let $y \in S_\ell^\alpha$, and let $\eta > 0$. For all $k_0 \in \mathcal{V}^\ell$, there exist a neighborhood V of y in Z_α , $C > 0$ and $\delta \in (0, 1)$ such that*

$$\|u\|_{H^1(V)} \leq C \|u\|_{H^1(Z)}^{1-\delta} \left(\sum_{k \in \mathcal{V}^\ell} \|f_k\|_{L^2(Z_k)} + \sum_{\substack{k \in \mathcal{V}^\ell \\ k \neq k_0}} \|u\|_{H^1(Y_k^\eta)} \right)^\delta,$$

for all $u \in H^1(Z)$ solution of (5.3), with $f \in L^2(Z)$.

This result corresponds to an observation from $(n-1)$ -sides of the interface S_ℓ^α , where $n = \text{Card } \mathcal{V}^\ell$, and quantifies the unique continuation property.

The following lemmas are classical. The first one allows one to propagate interpolation inequalities away from boundaries and interfaces.

Lemma 5.4. *Let U_k be an open subset compactly embedded in $(0, X_0) \times \Omega_k$ and $\eta' > 0$. There exist $C > 0$ and $\delta > 0$ such that*

$$\|u\|_{H^1(Y_k^{\eta'})} \leq C \|u\|_{H^1(Z_k)}^{1-\delta} \left(\|(\partial_{x_0}^2 + \Delta_{g_k})u\|_{L^2(Z_k)} + \|u\|_{L^2(U_k)} \right)^\delta, \quad (5.5)$$

for all $u \in H^1(Z_k)$ such that $(\partial_{x_0}^2 + \Delta_{g_k})u \in L^2(Z_k)$.

The second one allows one to propagate interpolation inequalities up to the boundaries. We also have the following estimate, in a neighborhood of the boundary $\{x_0 = 0\} \times \omega$, where no boundary conditions are known. We refer to [27] for a proof.

Lemma 5.5. *Let $x_0 \in \omega_k$, $k \in \mathcal{L}$. There exist V a neighborhood of the point $(0, x_0)$ in $\mathbb{R} \times \mathbb{R}^d$, $\delta \in (0, 1)$ and $C > 0$ such that*

$$\|u\|_{H^1(V \cap Z)} \leq C \|u\|_{H^1(Z_k)}^{1-\delta} \left(\|(\partial_{x_0}^2 + \Delta_{g_k})u\|_{L^2(Z_k)} + |u|_{x_0=0}|_{L^2(\omega_k)} + |\partial_s u|_{x_0=0}|_{L^2(\omega_k)} \right)^\delta. \quad (5.6)$$

for all $u \in H^1(Z_k)$ such that $(\partial_{x_0}^2 + \Delta_{g_k})u \in L^2(Z_k)$.

Proof of Lemma 5.3. This lemma is a consequence of the Carleman estimate. We shall place ourselves in a system of coordinates as given in Section 2, in a neighborhood \mathcal{U} of a point $z^0 = (z_0^0, x^0) \in S_\ell^\alpha$, with $x_d^0 = 0$. We shall write $\mathcal{U}^+ = \mathcal{U} \cap \mathbb{R}_+^{d+1}$. We define two anisotropic distances in \mathbb{R}^{d+1} , for all $z^1, z^2 \in \mathbb{R}^{d+1}$,

$$d_\gamma(z^1, z^2)^2 = \gamma |(z_0^1, (z^1)') - (z_0^2, (z^2)')|^2 + |z_d^1 - z_d^2|^2, \quad (5.7)$$

$$d_\gamma^\beta(z^1, z^2)^2 = \gamma |(z_0^1, (z^1)') - (z_0^2, (z^2)')|^2 + \beta |z_d^1 - z_d^2|^2. \quad (5.8)$$

For $k \in \mathcal{V}^\ell \setminus \{k_0\}$, we define with $z^1 \in \mathbb{R}^{d+1}$, the weight function $\varphi_k(z^1, z) = e^{\lambda d_\gamma(z^1, z)^2}$, and for $k = k_0$ we define $\varphi_{k_0}(\bar{z}^1, z) = e^{\lambda d_\gamma^\beta(\bar{z}^1, z)^2}$, with $\bar{z}^1 = (z_0^1, (z^1)', -z_d^1)$, that is, the symmetric of z^1 with respect to the axis $\{x_d = 0\}$. Note first that for $\lambda > 0$ sufficiently large, this family of weight functions satisfies the sub-ellipticity property (see Lemma 2.2) in $\overline{\mathcal{U}^+}$. For $z^1 \in \mathbb{R}_+^{d+1}$, it satisfies also conditions (3.15). Indeed, we have

$$\partial_{x_d} \varphi_k|_{x_d=0} = 2\lambda x_d^1 \varphi_k(z^1, z)|_{x_d=0} > 0, \text{ for } k \neq k_0 \text{ and } , \quad \partial_{x_d} \varphi_{k_0}|_{x_d=0} = -2\lambda x_d^1 \varphi_{k_0}(z^1, z)|_{x_d=0} < 0,$$

and moreover, by choosing $\gamma > 0$ and $\beta > 0$ sufficiently small, we can ensure that the covering condition is fulfilled. It is now classical that, using the Carleman estimate of Theorem 2.6, we can obtain the interpolation inequality of Lemma 5.3. We choose $r_0 > 0$ such that $z^1 = (0, r_0) \in \mathbb{R}_+^{d+1}$. We define the following cut-off functions $\chi_0, \chi_1 \in C_0^\infty(\mathbb{R}^{d+1})$:

$$\chi_0(x) = \begin{cases} 0 & \text{in } x_d > r_1 \\ 1 & \text{in } x_d \in [0, r_1/2] \end{cases} ; \quad \chi_1(x) = \begin{cases} 0 & \text{if } d_\gamma(z, z^1) \leq r_2 \text{ or } d_\gamma(y, y_0) > r_5 \\ 1 & \text{in } d_\gamma(z, z^1) \in [r_3, r_4], \end{cases}$$

and

$$\bar{\chi}_1(x) = \begin{cases} 0 & \text{if } d^\beta(z, z^1) \leq r_2 \text{ or } d^\beta(z, z^1) > r_5 \\ 1 & \text{in } d^\beta(z, z^1) \in [r_3, r_4], \end{cases}$$

with $0 < r_1 < r_0$ and $0 < r_2 < r_3 < r_4 < r_5$ such that

- r_3 is small enough to have $\overline{B_\gamma(z^1, r_3)} \cap \overline{\mathcal{U}^+} = \emptyset$, where B_γ denotes the open ball associated with the distance d_γ ;
- r_1 small enough and $r_0 < r_4 < r_5$ are such that $\{z = (z_0, x) \in \mathbb{R}_+^{d+1} \mid x_d \leq r_1\} \cap \{r_4 \leq d_\gamma(z, z^1) \leq r_5\} \subset \mathcal{U}^+$.

We can apply the Carleman estimate of Theorem 2.6 on \mathcal{U}^+ to $w_k = \chi_0 \chi_1 u_k$, for $k \neq k_0$, and $w_{k_0} = \bar{\chi}_1 u_{k_0}$: there exist $\tau_0 > 0$ such that

$$\sum_{k \in \mathcal{V}^\ell} \tau^{-1} \|e^{\tau \varphi_k} w_k\|_{2, \tau}^2 \leq C \left(\sum_{k \in \mathcal{V}^\ell} \|e^{\tau \varphi_k} (\partial_{y_0}^2 + \Delta_{g_k}) w_k\|_{L^2(Z_k)}^2 + \left| e^{\tau \varphi_{k_0}} \sum_{k \in \mathcal{V}^\ell} \partial_{y_d} w_k|_{\{y_d=0\}} \right|_{1/2, \tau}^2 \right),$$

for all $\tau \geq \tau_0$. For $k \neq k_0$, the right hand side can be estimated as follows

$$\begin{aligned} \|e^{\tau \varphi_k} (\partial_{y_0}^2 + \Delta_{g_k}) w\|_{L^2(Z_k)} &\lesssim \|e^{\tau \varphi} (\partial_{y_0}^2 + \Delta_{g_k}) u\|_{L^2(Z_k)} + \|e^{\tau \varphi} [(\partial_{y_0}^2 + \Delta_{g_k}), \chi_0 \chi_1] u\|_{L^2(Z_k)} \\ &\lesssim e^{\tau C_3} \|(\partial_{y_0}^2 + \Delta_{g_k}) u\|_{L^2(Z_k)} + e^{\tau C_3} \|u\|_{H^1(\mathcal{U}^+ \cap \{y_d \in [r_1/2, r_1]\})} + e^{\tau C_1} \|u\|_{H^1(Z_k)}, \end{aligned}$$

with $C_3 > e^{-\lambda(r_0 - r_1)}$ and $C_1 = e^{-\lambda r_4}$. Note that we have $C_1 < C_3$. Here, we use that the weight function φ is radial with respect to the distance d_γ to z^1 and decreasing as z moves away from z^1 , and the commutator $[(\partial_{y_0}^2 + \Delta_{g_k}), \chi_0 \chi_1]$ is a differential operator of order 1 supported in the region where $\chi_0 \chi_1$ varies. For $k = k_0$, we have

$$\begin{aligned} \|e^{\tau \varphi_{k_0}} (\partial_{y_0}^2 + \Delta_{g_{k_0}}) w\|_{L^2(Z_{k_0})} &\lesssim \|e^{\tau \varphi} (\partial_{y_0}^2 + \Delta_{g_{k_0}}) u\|_{L^2(Z_{k_0})} + \|e^{\tau \varphi} [(\partial_{y_0}^2 + \Delta_{g_{k_0}}), \chi_0 \chi_1] u\|_{L^2(Z_{k_0})} \\ &\lesssim e^{\tau C_3} \|(\partial_{y_0}^2 + \Delta_{g_{k_0}}) u\|_{L^2(Z_{k_0})} + e^{\tau C_1} \|u\|_{H^1(Z_{k_0})}, \end{aligned}$$

In the same spirit,

$$\left| e^{\tau \varphi_{k_0}} \sum_{k \in \mathcal{V}^\ell} \partial_{y_d} w_k|_{\{y_d=0\}} \right|_{1/2, \tau} \lesssim e^{\tau C_3} \left| \sum_{k \in \mathcal{V}^\ell} \partial_{y_d} u_k|_{\{y_d=0\}} \right|_{1/2, \tau} + e^{\tau C_1} \|u_{k_0}\|_{H^1(Z_{k_0})}$$

Finally, we can restrict the left hand side of the Carleman estimate to $\tilde{W} := B(0, r_6) \cap \{y_d > 0\}$ with $r_6 > 0$ taken sufficiently small to have $\chi_0 \chi_1 = 1$ on $B(0, r_6)$ and this yields, for $\tau \geq 1$,

$$\sum_{k \in \mathcal{V}^\ell} \tau^{-1} \|e^{\tau \varphi_k} w_k\|_{2, \tau} \gtrsim e^{\tau C_2} \|u\|_{H^2(\tilde{W})},$$

where $C_2 > \inf_k \inf_{\overline{W}} \varphi_k$, and $\tau \geq \tau_0$, with τ_0 taken sufficiently large. Note that we have $0 < C_1 < C_2 < C_3$. We finally obtain, coming back to the original coordinates, for some $\eta > 0$,

$$\begin{aligned} \|u\|_{H^1(V)} &\lesssim e^{\tau(C_3 - C_2)} \left(\sum_{k \in \mathcal{V}^\ell} \|(\partial_{x_0}^2 + \Delta_{g_k}) u_k\|_{L^2(Z_k)} + \sum_{k \in \mathcal{V}^\ell, k \neq k_0} \|u\|_{H^1(Y_{\ell, k}^\eta)} + \left\| \sum_{k \in \mathcal{V}^\ell} \partial_{\nu_k} u_k|_{S_\ell} \right\|_{L^2(S_\ell)} \right) \\ &\quad + e^{-\tau(C_2 - C_1)} \|u\|_{H^1(Z)}, \end{aligned}$$

where V is an open neighborhood of y_0 in \bar{Z} . It remains to optimize this inequality with respect to τ to obtain the result. \square

5.4 A spectral inequality

Define $\mathbb{L}^2 := \bigoplus_{k=1}^p L^2(\Omega_k)$, and more generally $\mathbb{H}^s := \bigoplus_{k=1}^p H^s(\Omega_k)$. We consider the operator defined on Ω by

$$\mathcal{A}(u_1, \dots, u_p) = (-\Delta_{g_1} u_1, \dots, -\Delta_{g_p} u_p), \quad (5.9)$$

with domain

$$D(\mathcal{A}) = \{u = (u_1, \dots, u_p) \in \mathbb{H}^1, \mathcal{A}(u) \in \mathbb{L}^2, \forall \ell \in \{1, \dots, L\}, u_1|_{\mathcal{I}_\ell} = \dots = u_p|_{\mathcal{I}_\ell} = 0, \sum_{k \in \mathcal{V}^\ell} \partial_{\nu_k} u_k|_{\mathcal{I}_\ell} = 0 \\ \text{and } u_i|_{\mathcal{B}_j} = 0, \forall j \in \{1, \dots, K\}, \forall i \in \mathfrak{M}_j\} \quad (5.10)$$

where ν_k is the outward unit vector on \mathcal{I}_ℓ in the sense of the metric g_k . This operator admits an orthonormal basis of eigenfunctions.

Proposition 5.6. *There exists a Hilbert basis of \mathbb{L}^2 composed by eigenfunctions $\phi^k = (\phi_1^k, \dots, \phi_p^k) \in \mathbb{L}^2$ of the operator \mathcal{A} , associated with eigenvalues $0 < \gamma_0 \leq \gamma_1 \leq \dots$ with $\lim_{j \rightarrow \infty} \gamma_j = +\infty$.*

The following spectral inequality that measures the loss of orthogonality of the eigenfunctions ϕ_j , $j \in \mathbb{N}$, when they are restricted to an open subset $\omega \subset \Omega$ such that $\bar{\omega} \neq \Omega$. It also quantifies how linear combinations of these eigenfunctions can be observed from a subdomain. It is a natural consequence of the interpolation inequality if Theorem 5.2 (see [21]).

Theorem 5.7 (Spectral inequality). *Let $\omega \subset \Omega$ be an open subset such that (ω, Ω) is observable in the sense of Definition 5.1. There exists $C > 0$ such that for all $\gamma \geq 0$ we have*

$$\|w\|_{L^2(\Omega)} \leq e^{C\sqrt{\gamma}} \|w\|_{L^2(\omega)}, \quad w \in \text{span}(\phi_j; \gamma_j \leq \gamma). \quad (5.11)$$

By the Lebeau-Robbiano method (see for instance the survey [21] for an exposition of the method, and the references therein), from the above spectral inequality, we can construct a control for the following heat equation. Let ω be an open subset of Ω .

$$\begin{cases} \partial_t u_k - \Delta_{g_k} u_k = \chi_k f_k & \text{in } (0, T) \times \Omega_k, k \in \{1, \dots, p\} \\ u_i|_{\mathcal{I}_\ell} = u_j|_{\mathcal{I}_\ell} & \text{at } (0, T) \times \mathcal{I}_\ell, \ell \in \{1, \dots, L\}, i, j \in \mathcal{V}^\ell \\ \sum_{k \in \mathcal{V}^\ell} \partial_{\nu_k} u_k|_{\mathcal{I}_\ell} = 0 & \text{at } (0, T) \times \mathcal{I}_\ell, \ell \in \{1, \dots, L\} \\ u_i|_{\mathcal{B}_j} = 0 & \text{at } (0, T) \times \mathcal{B}_j, j \in \{1, \dots, K\}, i \in \mathfrak{M}_j \\ (u_1|_{t=0}, \dots, u_p|_{t=0}) = (u_1^0, \dots, u_p^0) & \text{in } \{0\} \times \Omega, \end{cases} \quad (5.12)$$

where χ_k is a cut-off function such that $\text{supp } \chi_k \Subset \omega$. We state the null-controllability result of the heat equation 5.12.

Theorem 5.8. *Let $\omega \subset \Omega$ such that (ω, Ω) is observable in the sense of Definition 5.1. For any $T > 0$, there exists a constant $C > 0$ such that, for all initial data $(u_1^0, \dots, u_p^0) \in \mathbb{L}^2$, there exists a control $f := (f_1, \dots, f_p) \in L^2((0, T), \mathbb{L}^2)$, such that the solution $u = (u_1, \dots, u_p)$ of (5.12) satisfies $u(T) = 0$. Moreover the controls satisfy the bound*

$$\|f\|_{L^2((0, T), \mathbb{L}^2)} \leq C \sum_{k=1}^p \|u_k^0\|_{L^2(\Omega_k)}.$$

5.5 Stabilization of the wave equation

Let $\omega \subset \Omega$ be an open subset. We consider the following damped wave equation.

$$\begin{cases} \partial_t^2 u_k - \Delta_{g_k} u_k + a_k(x) \partial_t u_k = 0 & \text{in } (0, T) \times \Omega_k, k \in \{1, \dots, p\} \\ u_i|_{\mathcal{I}_\ell} = u_j|_{\mathcal{I}_\ell} & \text{at } (0, T) \times \mathcal{I}_\ell, \ell \in \{1, \dots, L\}, i, j \in \mathcal{V}^\ell \\ \sum_{k \in \mathcal{V}^\ell} \partial_{\nu_k} u_k|_{\mathcal{I}_\ell} = 0 & \text{at } (0, T) \times \mathcal{I}_\ell, \ell \in \{1, \dots, L\} \\ u_i|_{\mathcal{B}_j} = 0 & \text{at } (0, T) \times \mathcal{B}_j, j \in \{1, \dots, K\}, i \in \mathfrak{W}_k \\ (u_1|_{t=0}, \dots, u_p|_{t=0}) = (u_1^0, \dots, u_p^0) & \text{in } \{0\} \times \Omega, \\ (\partial_t u_1|_{t=0}, \dots, \partial_t u_p|_{t=0}) = (v_1^0, \dots, v_p^0) & \text{in } \{0\} \times \Omega, \end{cases} \quad (5.13)$$

where a_k is a non-negative compactly supported function satisfying $a_k \geq C > 0$ on ω , a non-empty subset of Ω . Observe that in the above wave equation, the damping terms are only directly effective on parts of Ω that intersect ω . We shall see that it is sufficient to ensure stabilization properties. We define the energy of the waves, solution to System (5.13) by

$$E(U, t) := \sum_{k=1}^p (\|u_k\|_{H^1(\Omega_k)}^2 + \|\partial_t u_k\|_{L^2(\Omega_k)}^2).$$

We can recast System (5.13) into a semi-group formalism

$$\dot{U} + BU = 0, \quad (5.14)$$

where $B = \begin{pmatrix} B_1 & & 0 \\ & \ddots & \\ 0 & & B_p \end{pmatrix}$, with $B_k = \begin{pmatrix} 0 & -1 \\ -\Delta_{g_k} & a_k(x) \end{pmatrix}$. We define the norm

$$\|(u_1, v_1, \dots, u_p, v_p)\|_{\mathbb{W}}^2 = \|(u_1, \dots, u_p)\|_{\mathbb{H}^1}^2 + \|(v_1, \dots, v_p)\|_{\mathbb{L}^2}^2.$$

We have the following result, that states that the energy of the strong solutions of (5.13) decays with a logarithmic speed.

Theorem 5.9. *Assume that (Ω, ω) is observable in the sense of Definition 5.1. There exists $C > 0$ such that*

$$E(U, t)^{1/2} \leq \log(2+t)^{-k} \|B^k U_0\|_{\mathbb{W}},$$

for all solutions $U = (u_1, \partial_t u_1, \dots, u_p, \partial_t u_p)$ of (5.14), with initial data $U_0 = (u_1^0, v_1, \dots, u_p^0, v_p)$.

It is well known [11, 3] that Theorem 5.9 follows from the following resolvent estimate. We define \mathbb{H}_0^1 the space of functions of \mathbb{H}^1 that satisfies at the boundary

$$u_i|_{\mathcal{B}_j} = 0 \text{ at } \mathcal{B}_j, j \in \{1, \dots, K\}, i \in \mathfrak{W}_k.$$

Proposition 5.10. *Let ω be a nonempty open subset of Ω and α be such that $\alpha > 0$ on ω . Then, the unbounded operator $i\sigma \text{Id} - B$ is invertible on $\mathbb{H} = \mathbb{H}_0^1 \times \mathbb{L}^2$ for all $\sigma \in \mathbb{R}$ and there exist $K > 0$ and $\sigma_0 > 0$ such that*

$$\|(i\sigma \text{Id} - B)^{-1}\|_{\mathcal{L}(\mathbb{H}, \mathbb{H})} \leq K e^{K|\sigma|}, \quad \sigma \in \mathbb{R}, |\sigma| \geq \sigma_0.$$

As in [26]), this is a consequence of the interpolation inequality of Theorem 5.2, using a propagation of interpolation inequalities arguments through the whole domain up to boundaries and through interfaces.

Acknowledgements. The author would like to thank Jérôme Le Rousseau and Luc Robbiano for many discussions on this work.

References

- [1] S. Agmon, A. Douglis, and L. Nirenberg. Estimates near the boundary for solutions of elliptic partial differential equations satisfying general boundary conditions. I. *Comm. Pure Appl. Math.*, 12:623–727, 1959. [2.3](#)
- [2] S. Agmon, A. Douglis, and L. Nirenberg. Estimates near the boundary for solutions of elliptic partial differential equations satisfying general boundary conditions. II. *Comm. Pure Appl. Math.*, 17:35–92, 1964. [2.3](#)
- [3] C. J. K. Batty and T. Duyckaerts. Non-uniform stability for bounded semi-groups on Banach spaces. *J. Evol. Equ.*, 8(4):765–780, 2008. [5.5](#)
- [4] Lucie Baudouin, Emmanuelle Crépeau, and Julie Valein. Global Carleman estimate on a network for the wave equation and application to an inverse problem. *Math. Control Relat. Fields*, 1(3):307–330, 2011. [\(document\)](#), [1](#), [5](#)
- [5] M. Bellassoued. Carleman estimates and distribution of resonances for the transparent obstacle and application to the stabilization. *Asymptot. Anal.*, 35(3-4):257–279, 2003. [1](#)
- [6] M. Bellassoued and J. Le Rousseau. Carleman estimates for elliptic operators with complex coefficients. Part I: Boundary value problems. *J. Math. Pures Appl. (9)*, 104(4):657–728, 2015. [\(document\)](#), [1](#), [4.2](#), [4.3](#)
- [7] M. Bellassoued and J. Le Rousseau. Carleman estimates for elliptic operators with complex coefficients Part II: transmission problems. *ArXiv e-prints*, May 2016. [\(document\)](#), [1](#), [3.2](#), [4.4](#), [4.4](#)
- [8] A. Benabdallah, Y. Dermenjian, and J. Le Rousseau. Carleman estimates for stratified media. *J. Funct. Anal.*, 260(12):3645–3677, 2011. [1](#)
- [9] A. Benabdallah, Y. Dermenjian, and L. Thevenet. Carleman estimates for some non-smooth anisotropic media. *Comm. Partial Differential Equations*, 38(10):1763–1790, 2013. [1](#)
- [10] R. Buffe. Stabilization of the wave equation with Ventcel boundary condition. *J. Math. Pures Appl. (9)*, 108(2):207–259, 2017. [1](#)
- [11] N. Burq. Décroissance de l'énergie locale de l'équation des ondes pour le problème extérieur et absence de résonance au voisinage du réel. *Acta Math.*, 180(1):1–29, 1998. [5.5](#)
- [12] T. Carleman. Sur un problème d'unicité pur les systèmes d'équations aux dérivées partielles à deux variables indépendantes. *Ark. Mat., Astr. Fys.*, 26(17):9, 1939. [1](#)
- [13] René Däger and Enrique Zuazua. *Wave propagation, observation and control in 1-d flexible multi-structures*, volume 50 of *Mathématiques & Applications (Berlin) [Mathematics & Applications]*. Springer-Verlag, Berlin, 2006. [\(document\)](#), [1](#), [5](#)
- [14] M. Di Cristo, E. Francini, C.-L. Lin, S. Vessella, and J.-N. Wang. Carleman estimate for second order elliptic equations with Lipschitz leading coefficients and jumps at an interface. *J. Math. Pures Appl. (9)*, 108(2):163–206, 2017. [1](#)
- [15] A. Doubova, A. Osses, and J.-P. Puel. Exact controllability to trajectories for semilinear heat equations with discontinuous diffusion coefficients. *ESAIM Control Optim. Calc. Var.*, 8:621–661, 2002. A tribute to J. L. Lions. [1](#)

- [16] L. Hörmander. *Linear partial differential operators*. Die Grundlehren der mathematischen Wissenschaften, Bd. 116. Academic Press, Inc., Publishers, New York; Springer-Verlag, Berlin-Göttingen-Heidelberg, 1963. [2.1](#)
- [17] Lars Hörmander. On the uniqueness of the Cauchy problem. *Math. Scand.*, 6:213–225, 1958. [1](#)
- [18] Lars Hörmander. *Linear partial differential operators*. Springer Verlag, Berlin-New York, 1976. [1](#)
- [19] J. E. Lagnese, Günter Leugering, and E. J. P. G. Schmidt. *Modeling, analysis and control of dynamic elastic multi-link structures*. Systems & Control: Foundations & Applications. Birkhäuser Boston, Inc., Boston, MA, 1994. ([document](#)), [1](#), [5](#)
- [20] J. Le Rousseau, M. Léautaud, and L. Robbiano. Controllability of a parabolic system with a diffuse interface. *J. Eur. Math. Soc. (JEMS)*, 15(4):1485–1574, 2013. [1](#)
- [21] J. Le Rousseau and G. Lebeau. On Carleman estimates for elliptic and parabolic operators. Applications to unique continuation and control of parabolic equations. *ESAIM Control Optim. Calc. Var.*, 18(3):712–747, 2012. [5.4](#), [5.4](#)
- [22] J. Le Rousseau and N. Lerner. Carleman estimates for anisotropic elliptic operators with jumps at an interface. *Anal. PDE*, 6(7):1601–1648, 2013. [3.2](#)
- [23] J. Le Rousseau and L. Robbiano. Carleman estimate for elliptic operators with coefficients with jumps at an interface in arbitrary dimension and application to the null controllability of linear parabolic equations. *Arch. Ration. Mech. Anal.*, 195(3):953–990, 2010. [1](#)
- [24] J. Le Rousseau and L. Robbiano. Local and global Carleman estimates for parabolic operators with coefficients with jumps at interfaces. *Invent. Math.*, 183(2):245–336, 2011. [1](#)
- [25] G. Lebeau and L. Robbiano. Contrôle exact de l'équation de la chaleur. *Comm. Partial Differential Equations*, 20(1-2):335–356, 1995. [1](#), [5.3](#)
- [26] G. Lebeau and L. Robbiano. Stabilisation de l'équation des ondes par le bord. *Duke Math. J.*, 86(3):465–491, 1997. [1](#), [5.3](#), [5.5](#)
- [27] G. Lebeau and E. Zuazua. Null-controllability of a system of linear thermoelasticity. *Arch. Rational Mech. Anal.*, 141(4):297–329, 1998. [5.3](#)
- [28] L. Robbiano. Fonction de coût et contrôle des solutions des équations hyperboliques. *Asymptotic Anal.*, 10:95–115, 1995. [5.3](#)
- [29] D. Tataru. Carleman estimates and unique continuation for solutions to boundary value problems. *J. Math. Pures Appl. (9)*, 75(4):367–408, 1996. [1](#)
- [30] Enrique Zuazua. Control and stabilization of waves on 1-d networks. In *Modelling and optimisation of flows on networks*, volume 2062 of *Lecture Notes in Math.*, pages 463–493. Springer, Heidelberg, 2013. ([document](#)), [1](#), [5](#)