



HAL
open science

Battery Monitoring System using switching battery cells

G. Despesse, S Lechat Sanjuan, S Gery

► **To cite this version:**

G. Despesse, S Lechat Sanjuan, S Gery. Battery Monitoring System using switching battery cells. Research & Innovation for Transport Systems of the Future, Nov 2012, Paris, France. pp.12 - 15. hal-01681862

HAL Id: hal-01681862

<https://hal.science/hal-01681862v1>

Submitted on 11 Jan 2018

HAL is a multi-disciplinary open access archive for the deposit and dissemination of scientific research documents, whether they are published or not. The documents may come from teaching and research institutions in France or abroad, or from public or private research centers.

L'archive ouverte pluridisciplinaire **HAL**, est destinée au dépôt et à la diffusion de documents scientifiques de niveau recherche, publiés ou non, émanant des établissements d'enseignement et de recherche français ou étrangers, des laboratoires publics ou privés.

Battery Monitoring System using switching battery cells

G. Despesse, S. Lechat Sanjuan, S. Gery

CEA-LETI, CEA-LITEN, Minatec Campus, 17 rue des Martyrs - 38054 Grenoble Cedex 9, France

ABSTRACT

As opposed to the first battery technologies (Pb, Ni-Mh...), whose protection and management required simple electronic circuits, today's Li-ion batteries need to be precisely supervised during all their working cycles to limit their charges and discharges, to ensure their security and improve their lifetime. Battery management is currently performed by monitoring battery cell voltages: charging is interrupted when the voltage of the first cell of the serial arrangement exceeds a threshold value (charging then goes forward with a lower current for the remaining cells). Battery discharge is managed similarly and is interrupted when the voltage of first battery cell falls below a threshold value. The remaining energy in the other cells of the serial arrangement is not used. Hence, the energy stored into the battery is not fully exploited, which limits the autonomy of the supplied system. Non-dissipative solutions to exchange energy between cells so as to maintain the cells balanced have been reported; yet, they require a large number of DC/DC converters with associated size, weight and price drawbacks. To overcome these limitations and to remove the battery charger and output converter (DC/DC or DC/AC converter to supply the load), we propose a full converter based on battery cell switching, to adjust the battery pack output voltage to the effective need in real time and maintain the battery cells balanced. The architecture we developed consists in connecting or disconnecting in real time each cell placed in the serial arrangement. In the case of an electrical vehicle with 30kWh on board, by using battery cells of 3.3V, the output voltage can be adjusted by steps of 3.3V from -60V to +60V. We show that it is possible to directly drive a three-phase electric motor with an efficiency up to 98% from few Hz to 400Hz, while maintaining the cells balanced. Moreover, this is achieved with a transistor cost lower than 300€ (consumer prices, expectedly 10 times lower for large quantities). For the transistor driving part, a distributed electronic is placed in front of each cell of the serial arrangement. Each distributed electronic circuit is able to drive up to 14 transistors, to carry out local measurements (temperature, current, voltage) and to calculate the estimated State of Charge of the local cell. Distributed electronic circuits communicate with an electronic advisor by using galvanically isolated a common serial communication bus.

SWITCHED BATTERY STRUCTURE

Standard battery architectures for electric vehicles are based on a battery arrangement of s battery levels connected in series, and battery levels are composed of p cells connected in parallel. This battery pack is connected on one side to a charger (to recharge the battery on the electrical network) and on the other side to the electric motor by an inverter (DC/DC or DC/AC electrical converter depending on the type of the motor to supply).

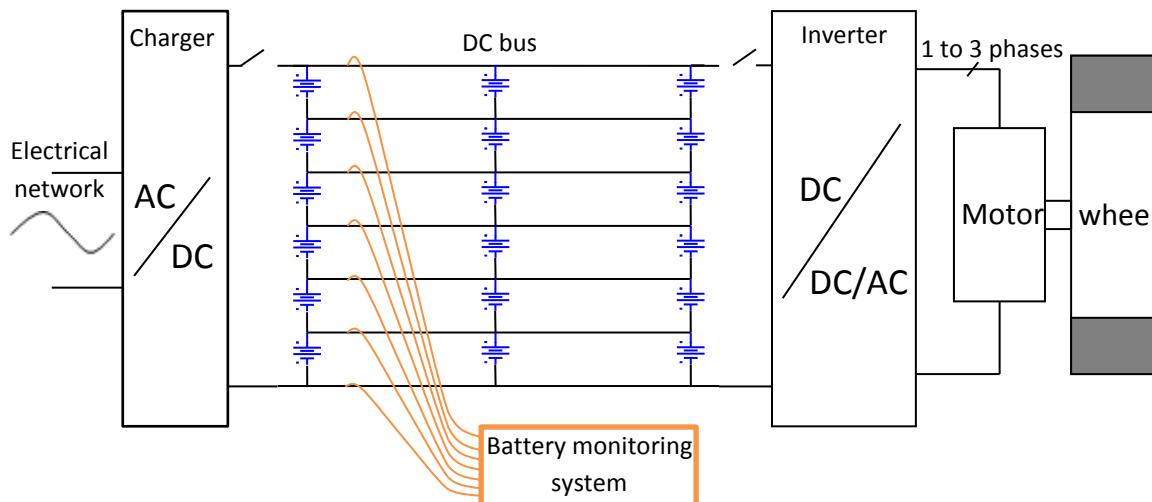

Figure 1 : Standard architecture around the battery pack

In typical applications, the number s of cells placed in series ranges from 15 ($\approx 48V$ on DC bus) to few hundreds (up to 900 V on DC bus).

In this architecture, if one battery fails, the complete battery pack capability to provide a current is significantly reduced. To overcome this, one solution is to divide the battery pack into a few electrically connectable/disconnectable modules. If one cell fails, a single module of the battery pack is isolated, enabling the system to continue its operation. This is illustrated in Fig. 2.

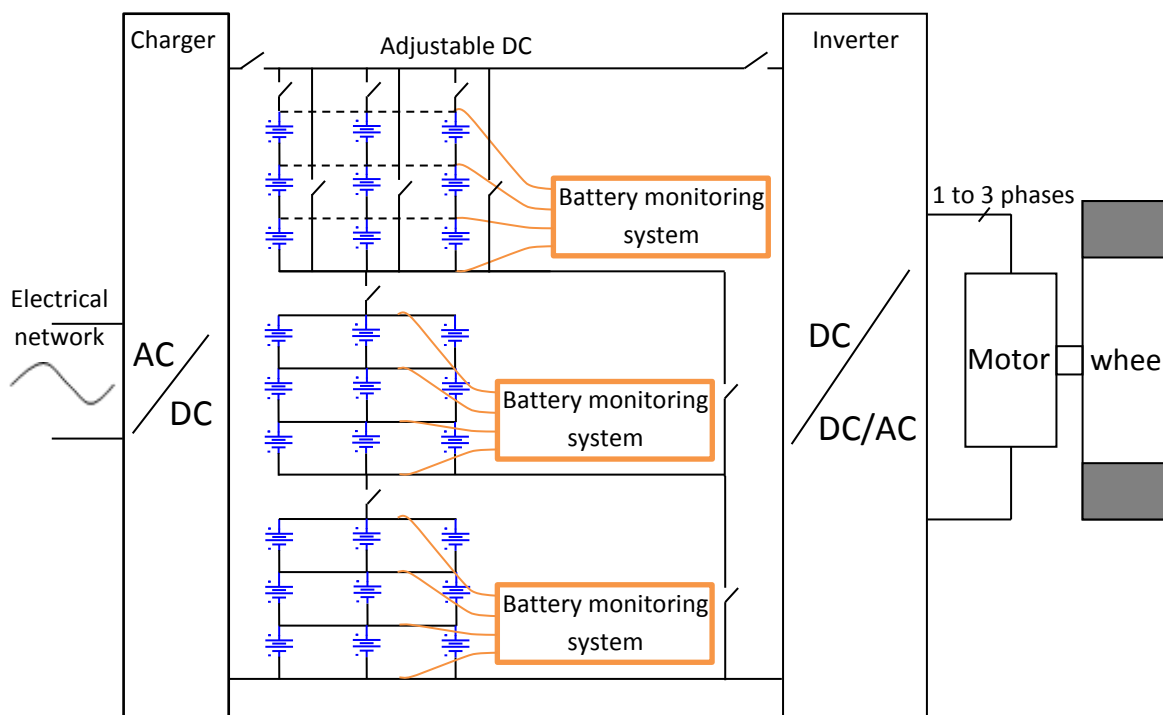

Figure 2 : Battery pack composed of connectable/disconnectable modules

The current through the battery pack in electrical vehicles can exceed 100 A (depending on the continuous bus voltage and the embedded power level) and the transistor cost increases as a function of the current level that the transistor can withstand. As a result, a two-switch-per-module configuration may not be the

most suitable option. At constant price and constant losses, it is interesting to decrease the transistor size and increase the number of transistors, which in addition multiplies the physical dissipating points and decreases the losses on each point, making it easier to maintain the temperature of the system without any costly and heavy radiators. Multiplying the number of transistors also ensures redundancy, which increases security and shortens electrical connections (one does not need to concentrate the whole current in one transistor and redistribute it afterwards). Transistor multiplication can be implemented as represented on the upper module of Figure 2. This enables module division into several commutable columns and single module subpart isolation.

The number of serial cells to be placed in each module is mainly related to the voltages that the transistors can support. Transistor cost is proportional to its maximum voltage. It is thus suitable to divide the battery pack into many small voltage modules in order to improve the battery granularity. An optimum module voltage is around 25V, since below this limit, the individual transistor cost is no longer proportional to the voltage and becomes constant. 25V are equivalent to 4 or 5 serial battery cells depending on their maximum voltage. This module voltage is close to the standard maximum MOSFET gate-source voltage V_{gs} and hence easily drivable. Furthermore, small voltage modules enable to reduce voltage slew rates and corresponding electromagnetic perturbations during transistor transitions.

With the optimal module size in terms of transistor cost sorted, the system now requires a Battery Monitoring System (BMS) in each module (to ensure cell balancing inside each module), a charger and an inverter. The cell balancing circuit can be replaced by single-serial-cell modules, cell balancing thus proceeding by using more often the modules having higher States of Charge and less often the modules having lower States of Charge. With such modules, the output voltage can be adjusted by steps of a single battery cell voltage (3.2V/3.6V for Li-ion battery). By dynamically switching the modules, it becomes possible to produce a near-perfect sinusoidal waveform that can directly drive an electrical motor. As the output voltage step is lower than the resistive voltage drop in classical electric chains, one can also directly recharge the battery pack on the electrical network without any or with a very low size inductor. In conclusion, dynamic switching of the modules would enable to get rid of the costly inverter and its cooling system, the costly and heavy capacitor placed before the inverter to filter the current, the costly and heavy charger and the costly converter placed in the rapid charging stations. Furthermore, as the battery cell voltages tend to increase with the new battery technologies and the power transistor voltages tend to decrease with the transistors gate length reduction, there is a good chance that in the near future, optimal cost architectures will indeed tend towards modules of only one serial cell.

The objectives of this work are (i) to evaluate the feasibility of completely replacing the charger, the inverter and the battery cell balancing by module dynamic switching, (ii) to estimate the effects on the global structure and (iii) to identify the main challenges of implementing such a solution. Two prototypes have been fabricated to validate this principle, as described below.

FIRST PROTOTYPE DESIGN

Our first prototype is based on 18 modules having only one serial cell ($s=1$) and four parallel cells ($p=4$) as presented in figure 3:

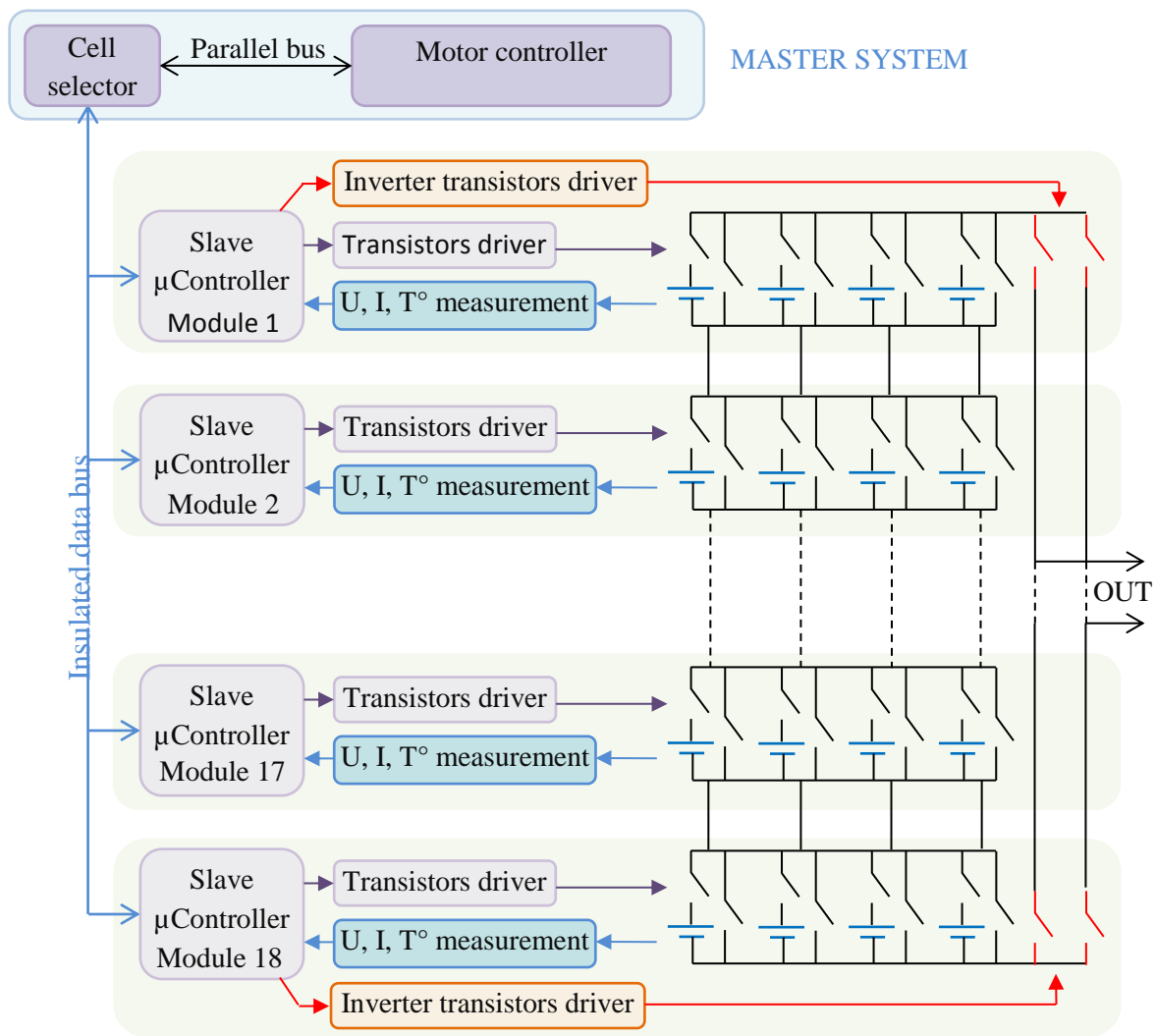

Figure 3 : Schematic of the first prototype

This prototype is designed to manage $18 \times 4 = 72$ battery cells of 40A.h, representing 9.5kWh (considering 3.3V battery cells). Chosen transistors are MOSFETs (IRFH5250DTR2PBF) and allow a continuous current of 40A without any thermal radiator. An inverter is placed at the output to invert or to reproduce the output voltage. This inverter is driven by the upper and the lower modules.

Each module has its own electronic circuit which aims at:

- Sensing the current, voltage and temperature of each battery cell
- Computing the state of charge and the state of health of each battery cell
- Driving the power transistors through orders sent out by a master system
- Sending the measurement data to the master system via an insulated serial bus
- Ensuring security by opening the transistors in case of short circuit detection, too high temperature measurement or computational bug

The “Motor controller” block of the master system calculates in real time the number n of battery cells to place in series to reach the voltage required to drive a three-phase electric motor. The “Cell selector” block then selects n modules to use depending on their state of charge (for maintaining cell balancing), their current capability and their temperature.

Motor controller

The motor controller works like multi-level inverters that are well-known in the state of the art [1-3]; figure 4 shows one output signal example that can be produced by such a device:

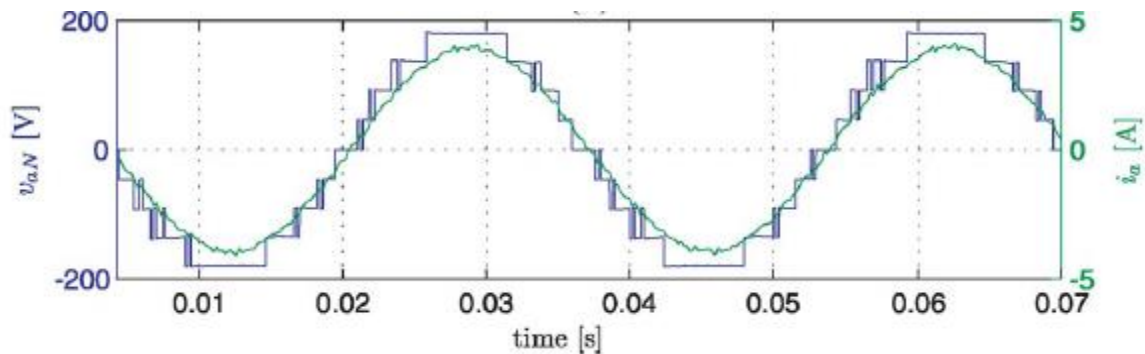

Figure 4 : Output voltage example of a multilevel generator [1]

The main advantages of these multilevel inverters are:

- Low switching losses due to the lower voltages to switch (losses proportional to $f \cdot C \cdot V^2$)
- Lower voltage transistors
- Limited EMC emissions and improvement of the voltage signal applied to the motor (no full voltage commutation at high frequency like in a classical inverter)
- Low size or no inductor to filter the current

In our case, the output voltage quantification level is so low (few volts) that it is not required to carry out pulse width modulation between two voltage levels unless in a very low frequency range ($< 5\text{Hz}$). Furthermore, in many cases, no inductor needs to be added to filter the current (for example to recharge the battery pack from the electrical network).

Cell selector

The “Cell selector” block collects data from each module, such as their state of charge, state of health, temperature and remaining current capability, by using a serial insulated bus common to all modules. This data provides the ranking priority order of modules to connect or to disconnect.

This block is mainly aimed at:

- balancing the state of charge of modules
- allowing the continuity of operation in case of faulty modules
- continuing to exploit the weakened modules when the current value enables it
- taking the modules' characteristics into account (all modules are not necessarily similar; they could be of different capacities or technologies)

Module

Each module embeds an electronic circuit powered by the energy available in the module and composed of:

- a micro-controller to decode orders from the master system, synthesize measurements, compute the states of charge, arbitrate the cells to use in the module, ensure security with extreme temperatures, currents and voltages
- a serial communication interface to communicate with the master system: the estimation of the module states is performed within the module and transmitted to the master system, which then computes the future configuration of the module (connection or disconnection) and transmits the order to it
- a measurement interface to sense the current, temperature and voltage of each cell
- a discrete logic circuit to open the shunt or serial transistors in case of short circuit or transistor failure detection
- a power driver interface to drive the 8 or 10 transistors of the module; this driver is able to command each transistor with 20V in less than 300ns

Power transistor driver

To drive the transistors, we have chosen to charge an inductor under 3.3V and to discharge it in the gate of the power NMOS to command. Figure 5 shows the corresponding electronic circuit and the experimental waveforms:

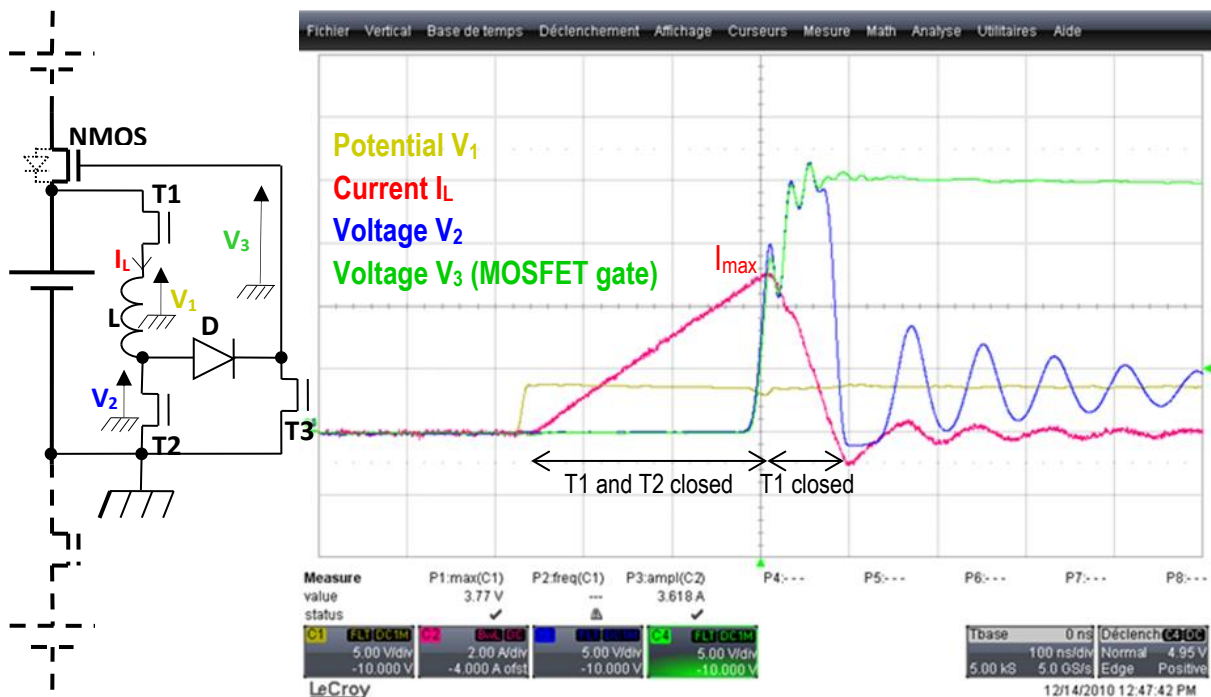

Figure 5 : Power transistor driver principle

When closing T1 and T2, the current in the inductor L increases as $I_L = U_L/L \cdot t$; this is verified experimentally (i.e. Figure 5: red curve). The final value of the energy stored in the inductor is $\frac{1}{2} \cdot L \cdot I_{max}^2$. This energy is then transferred to the gate of the power NMOS by opening T2, and becomes $\frac{1}{2} \cdot C_{GS} \cdot V_{GS}^2$. The energy stored in the inductor and then the gate voltage can be tuned by adjusting the inductor charging time. With a 47 nH inductor, the charging time to reach 20 V on the power NMOS gate is only about 300ns, which is negligible compared to the computation time of the motor controller.

If the NMOS command has to be maintained on its “on” state for more than 1ms, then a new energy pulse is sent to the NMOS gate every 1ms.

The NMOS is open by opening T1 and closing T3 which discharges the NMOS gate.

PROTOTYPE IMPLEMENTATION

The first prototype is composed of an electronic card designed to be screwed on the battery cells; we aim for as few cables as possible. The power transistors are placed to make the power path as short as possible. Figure 6 shows the first 9 modules management card of our first prototype. The next 9 modules are not represented for clarity but are just in the extension of the first card.

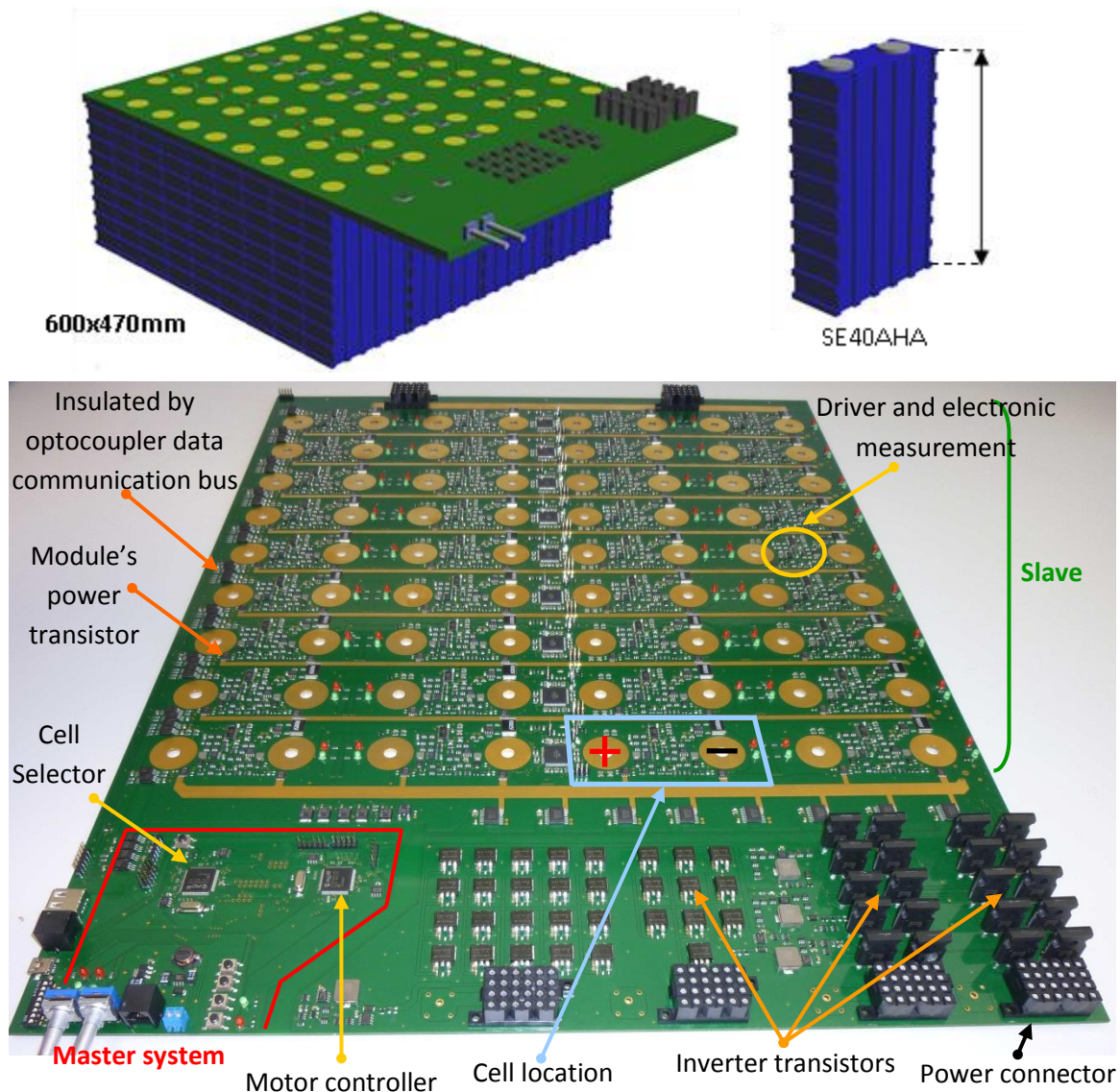

Figure 6 : Partial view of the first prototype

The inverter transistors are rather large and in significant number because they have to support the full voltage and are more resistive compared to the module's transistors which are nearly invisible on the picture.

EXPERIMENTAL RESULTS

The first prototype was tested on a low power 180 W ABB electric motor (for security reasons). As the prototype can only produce 1 phase, the other two were produced by using two four-quadrant converters driven by the same “Motor controller” block. Figure 7 shows the voltage and current waveforms applied to the electric motor.

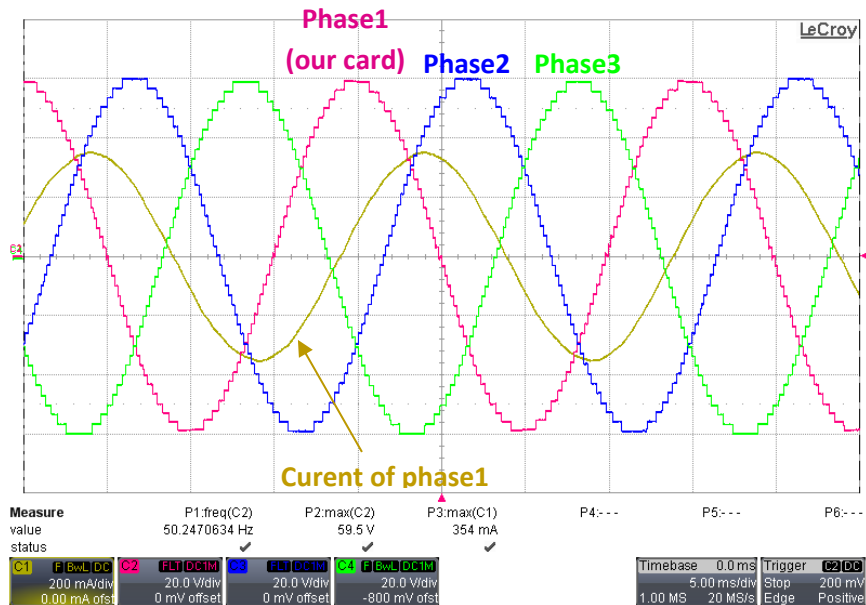

Figure 7 : Generated voltage and current waveforms

Figure 7 shows that the generated voltage is close to a pure sinus and that the current is particularly well filtered by the inductance of the motor windings.

The efficiency of the electrical conversion is higher than 99% in low power demand (< 2 kW) and decreases to 98% when the current reaches 160 A (nominal regime - 9.5 kW). This efficiency is significantly higher than that of standard embeddable inverters, which is no more than 90%, with moreover an induced high frequency voltage in the electrical motor. As a result, no cooling system is required to evacuate the losses, which limits the weight and cost.

The output inverter used to reverse the output voltage in our prototype does not induce many losses because it switches only twice per period and on 0V output voltage (at voltage inversion). Nevertheless, this inverter necessitates a lot of costly high voltage transistors. Furthermore, these transistors are dependent on the number of modules, which impedes the flexibility in terms of adding or removing of modules.

To overcome this limitation, we designed and fabricated a second prototype that duplicates the inverter on each module. The latter still works on a low voltage (<20 V) independently of the module number. This second prototype is presented in details in the following part.

SECOND PROTOTYPE ARCHITECTURE

The objectives of the second prototype are:

- to place an output voltage inverter on each module in order to only switch low voltages (no need of high voltage transistors even in the presence of a large number of modules)
- to enable a serial/parallel commutation of cells within the modules, according to 4 configurations: all parallel, parallel-serial-parallel, parallel-serial-serial, all serial.

The module architecture is presented in Fig. 8:

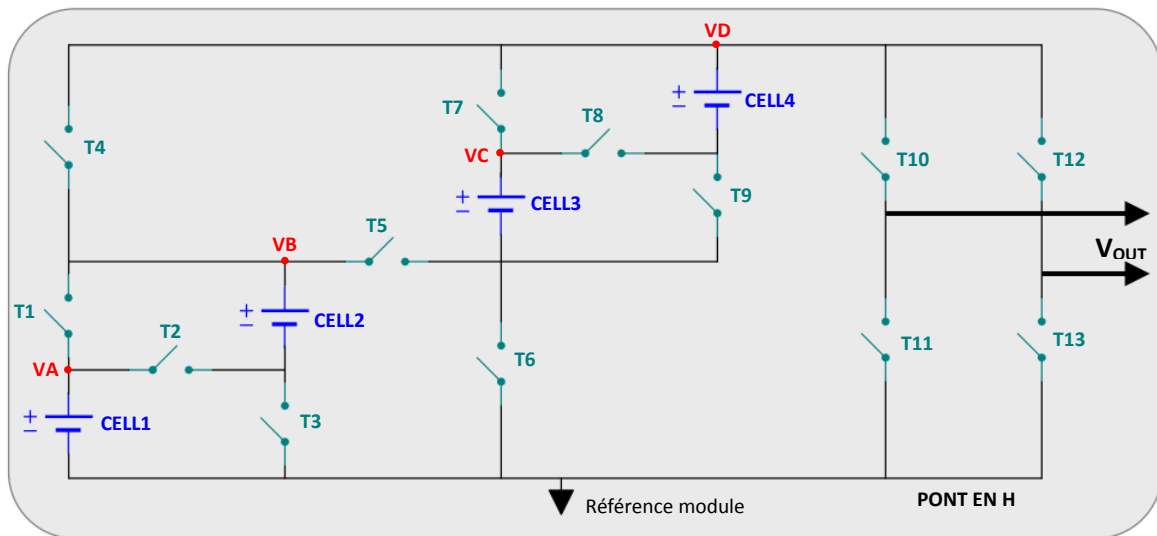

Figure 8 : Second prototype architecture

This module can produce a voltage from $-4V_{\text{cell}}$ to $+4V_{\text{cell}}$ per step of V_{cell} , where V_{cell} is the cell voltage.

This kind of module can be inserted in a serial arrangement to reach a large global output voltage and/or to store a large amount of energy. The configuration of each module is sorted in real time by a master system in order to provide the instantaneous required output voltage/current to drive, for example, an electric motor (Fig. 9).

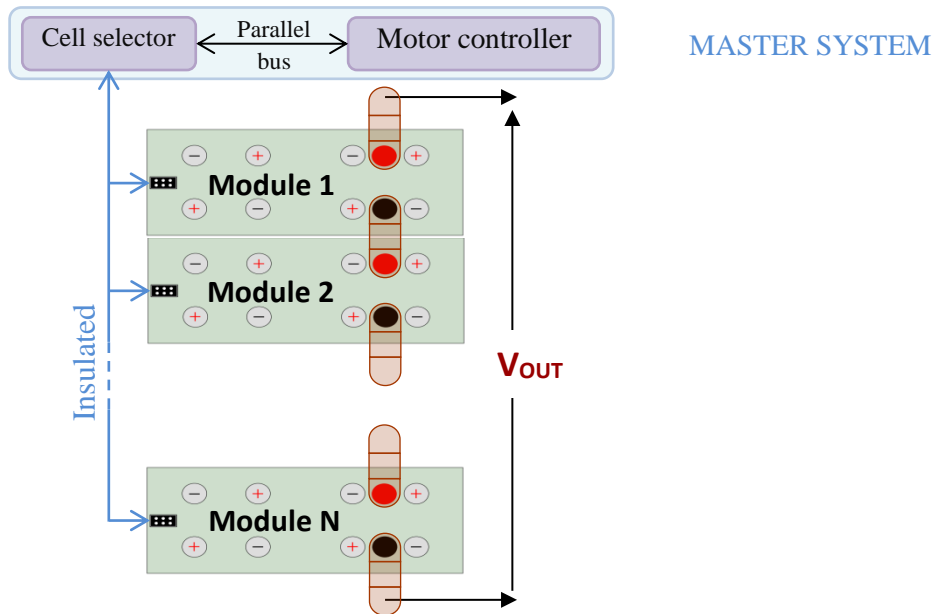

Figure 9 : Serial arrangement of modules of prototype 2

SECOND PROTOTYPE IMPLEMENTATION

The second prototype was also designed to manage 40 A.h battery cells; a picture of this prototype is presented in figure 10.



Figure 10 : Picture of the second prototype switched module

As the battery cells can be placed in parallel, the efficiency can significantly be increased in case of low output voltages compared to the first architecture; and much more compared to a standard inverter.

CONCLUSIONS

We have shown that it is possible to directly drive an electric motor by dynamically switching batteries with an efficiency up to 98%. Losses are very low and spatially distributed, which prevents the use of a cooling system. Although this solution requires numerous transistors, the latter operate in low voltage and hence are relatively cheap (less than 1\$). Overall, this solution is thus relatively cost-efficient (around 300

€ for transistors for 3 columns of 9.5 kWh) and the cost is bound to be significantly reduced through large scale production. This solution was validated with an electric motor; yet, it can also replace the normal and the fast battery charger without adding cost and weight to the vehicle. This solution can also significantly increase the security by withdrawing the failing cells, cutting the power path in many points in case of vehicle crash, flood, short circuit or simply during maintenance. The main remaining challenge is to increase the data bus speed for driving more modules and for producing an output wave at more than 500Hz (currently limited to 400 Hz).

REFERENCES

- [1] Patricio Cortés, Alan Wilson, Samir Kouro, Jose Rodriguez, Haitham Abu-Rub, *Model Predictive, Control of Multilevel Cascaded H-Bridge Inverters*, IEEE Transactions on industrial electronics, vol. 57, n°. 8, Août 2010
- [2] P. Palanivel, Subhransu Sekhar Dash, *Multicarrier Pulse Width Modulation Methods Based Three Phase Cascaded Multilevel Inverter Including Over Modulation and Low Modulation Indices*, TENCON 2009 - 2009 IEEE Region 10 Conference
- [3] P. Karuppanan, Kamala Kanta Mahapatra, *FPGA based Cascaded Multilevel Pulse Width Modulation for Single Phase Inverter*, Environment and Electrical Engineering (EEEIC), 2010, p273-276