



HAL
open science

Fibulin-2: genetic mapping and exclusion as a candidate gene in Marfan syndrome type 2.

G Collod, Mon Li Chu, T. Sasaki, M Coulon, R Timpl, L Renkart, J. Weissenbach, G. Jondeau, J P Bourdarias, C. Junien, et al.

► **To cite this version:**

G Collod, Mon Li Chu, T. Sasaki, M Coulon, R Timpl, et al.. Fibulin-2: genetic mapping and exclusion as a candidate gene in Marfan syndrome type 2.. *European Journal of Human Genetics*, 1996, pp.292-5. hal-01662932

HAL Id: hal-01662932

<https://hal.science/hal-01662932>

Submitted on 13 Dec 2017

HAL is a multi-disciplinary open access archive for the deposit and dissemination of scientific research documents, whether they are published or not. The documents may come from teaching and research institutions in France or abroad, or from public or private research centers.

L'archive ouverte pluridisciplinaire **HAL**, est destinée au dépôt et à la diffusion de documents scientifiques de niveau recherche, publiés ou non, émanant des établissements d'enseignement et de recherche français ou étrangers, des laboratoires publics ou privés.

Gwenaëlle Collod^a
 Mon-Li Chu^b
 Takako Sasaki^c
 Monique Coulon^a
 Rupert Timpl^c
 Loretta Renkart^b
 Jean Weissenbach^d
 Guillaume Jondeau^e
 Jean-Pierre Bourdarias^e
 Claudine Junien^{a,f}
 Catherine Boileau^{a,f}

^a INSERM U383, Hôpital Necker-Enfants Malades, Université René-Descartes, Paris, France;

^b Department of Biochemistry and Molecular Biology, Thomas Jefferson University, Philadelphia, Pa., USA;

^c Max-Planck-Institut für Biochemie, Martinsried bei München, Germany;

^d Généthon, Evry,

^e Service de Cardiologie, CHU Ambroise-Paré, Boulogne,

^f Laboratoire Central de Biochimie et de Génétique Moléculaire, Boulogne, France

Fibulin-2: Genetic Mapping and Exclusion as a Candidate Gene in Marfan Syndrome Type 2

Key Words

Marfan syndrome · Fibulin · Extra-cellular matrix protein

Abstract

Fibulin-2 (FBLN2) is a new extracellular matrix protein that has been considered a candidate gene for Marfan syndrome type 2 (locus MFS2) based on chromosomal colocation at 3p24.2-p25 and disease phenotype. In the absence of polymorphic markers reported for FBLN2, direct sequencing of the gene was performed and two intragenic polymorphisms were identified. Linkage was excluded between FBLN2 and the MFS2 gene. Furthermore, two-point lod scores were generated between these markers and anonymous markers arrayed on the genetic map of 3p and closely linked to MFS2. These analyses placed FBLN2 at marker D3S1585.

Introduction

Marfan syndrome (MFS) is an autosomal dominant connective-tissue disorder. It involves predominantly three systems (skeletal, ocular and cardiovascular systems) and is characterized by highly variable expressivity [1]. By excluding the disease locus fibrillin-1 (FBN1) in a large French family with typical cardiovascular and skeletal anomalies of Marfan syndrome, we demonstrated genetic heterogeneity in MFS and the implication of a second locus, MFS2. Linkage analyses have localized MFS2 to a region between markers D3S1293 and D3S2335 at 3p24.2-p25 [2, 3].

Fibulin-2 (FBLN2) is a multidomain, extracellular matrix protein whose function is still unknown. It contains 10 calcium binding EGF-like motifs [4] which are also observed in fibrillin-1 (FBN1) that carries the mutations accountable for Marfan syndrome type I. Furthermore expression studies of fibulin-2 mRNA in mouse tissues have shown strong hybridization signals in the heart [4-6]. Finally, FBLN2 has been localized by in situ hybridization at 3p24-p25 [5]. Therefore, FBLN2 represented an excellent functional and positional candidate gene for MFS2.

Fig. 1. Immunofluorescence demonstration of extracellular fibulin-2 networks in confluent fibroblast cultures. **a** Patient. **b** Unaffected control.

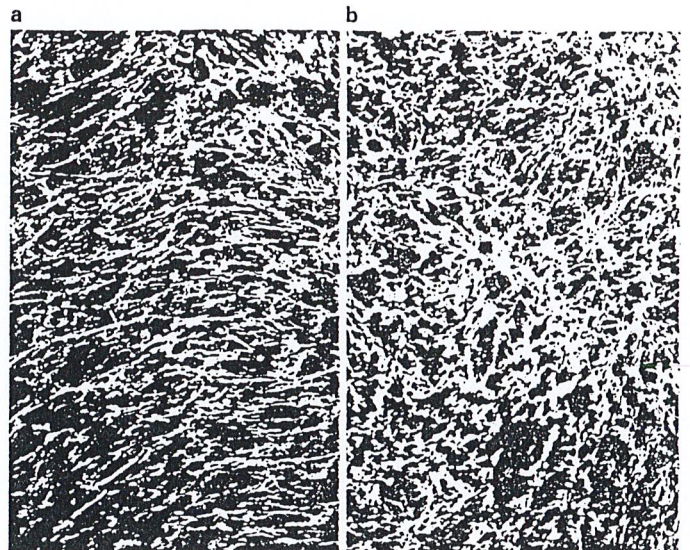

Protein Analyses

Indirect immunofluorescence and immunoblots were performed using affinity-purified polyclonal antibodies to fibulin-2 [4] on the networks deposited by fibroblasts from various affected family members. No significant difference was observed between patient and normal cells (fig. 1). Immunoblots of cell layer extracts demonstrated the same disulfide-bonded fibulin-2 trimers in both samples and, as measured by radioimmunoassay, a similar content of fibulin-2 in the range of 2–4 $\mu\text{g}/\text{mg}$ cellular protein. This was in agreement with expression studies: Northern analysis of total RNA from cultured fibroblasts identified a unique 4.1-kb band in affected and unaffected members as well as in a control, with no significant difference in intensities. These negative results did not exclude the possible existence in affected individuals of a fibulin-2 protein with abnormal structure or function.

Genetic Approach

We sequenced the gene *FBLN2* and identified a polymorphic site at nucleotide 2629 of G or A (alanine 827 to threonine) [5] revealing a new *Ava*II restriction site. This new marker was tested by amplification with BUL8A: 5' AACACGGTGGGCTCCTAC 3' (from nucleotide 2554 to 2571), and BUL8M: 5' GGT TGT GGC ACA CTT GGC 3' (from nucleotide 2701 to 2684) under the following conditions: 94°C for 5 min, 30 cycles at 94°C for 30 s, 53°C for 30 s, 72°C for 40 s followed by 72°C for 5 min.

PCR products were digested with *Ava*II that cleaves the 270-bp fragment (A1, frequency of 0.70) into 195 and 75 bp (A2, frequency of 0.30). A highly informative dinucleotide repeat polymorphism was also identified in the gene and the following primers were designed for its study: F9: 5' GTAGGTGCTCATTGGACAGTTG 3' and B9: 5' CCAAGGCTTCTGAAGGACTTGA 3' (the full description of the polymorphism will be described elsewhere). Cycling conditions were 94°C for 5 min, 30 cycles at 94°C for 30 s, 60°C for 30 s, 72°C for 40 s followed by 72°C for 5 min. PCR products were then analysed as described previously [3]. Two-marker haplotype analysis identified three recombinants among clearly affected (III4) and unaffected (III44 and IV55) family members. Furthermore, 3 possible recombinants were also identified in the group of subjects having an ambiguous phenotypic status [2, 7] and carrying the unrecombined 3p marker haplotype linked to *MFS2* (III13, III30 and IV53) (fig. 2). These results clearly excluded linkage between *MFS2* and the fibulin-2 gene. Furthermore, multipoint lod scores computed with various regional microsatellite markers (unpublished data), placed *FBLN2* at marker D3S1585 (maximum location score: 63.80 (lod score: 13.86) at $\theta = 0.0$).

Conclusions

In conclusion, our results show that *FBLN2* is not identical with *MFS2* and place the candidate gene on the genetic map of 3p, distal to the 7-cM critical region in which *MFS2* is located at present.

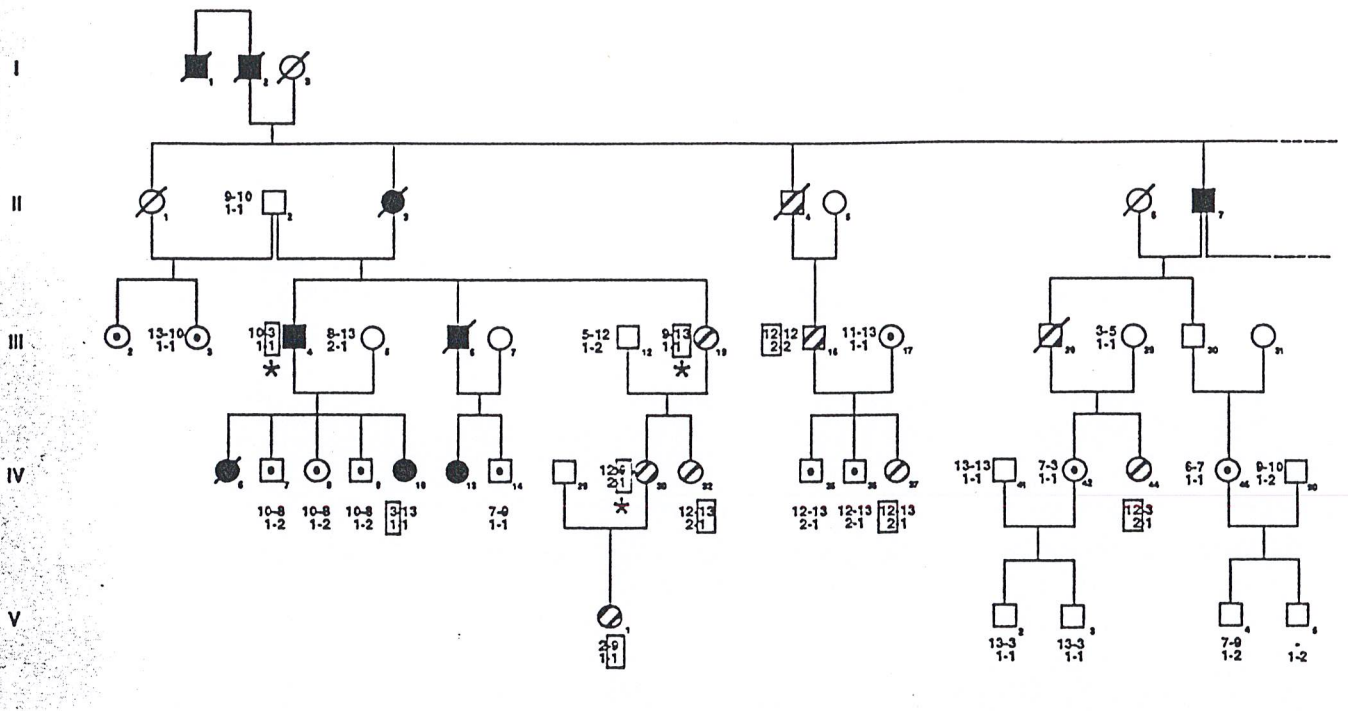
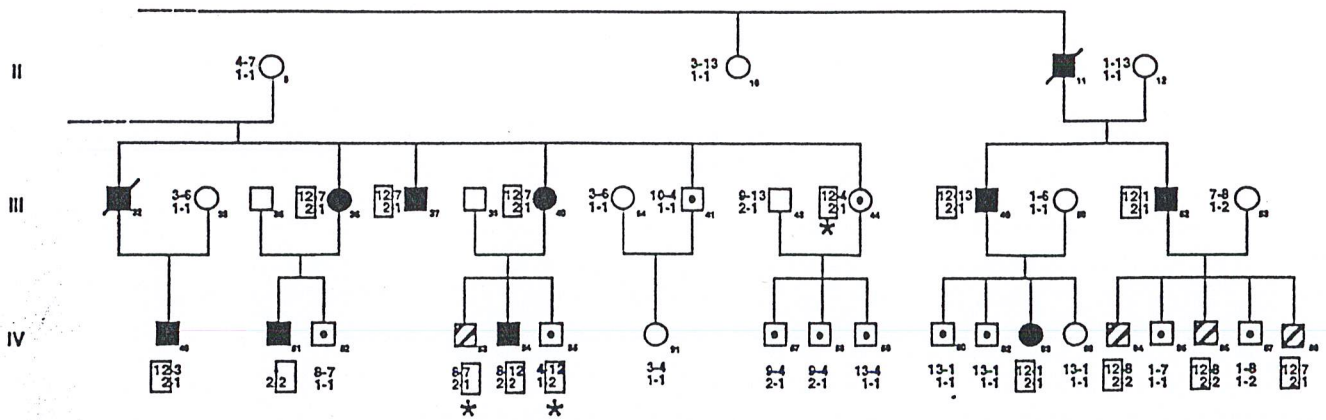

Fig. 2. Segregation of fibulin-2 markers in the Marfan kindred. Note that **a** and **b** represent different parts of a single pedigree, i.e., **b** is the rightward extension of **a**. Haplotypes at 'AvnlI' and '(CA)_n' markers are shown for each family member tested. Black symbols denote affected members, white symbols denote unaffected spouses or unexamined family members, white symbols with a dot in the center denote members considered unaffected, and hatched symbols denote members having an ambiguous phenotypic status and carrying the unrecom-

Acknowledgements

We are indebted to family members for their cooperation. G.C. is supported by a grant from Société de Secours des Amis des Sciences. Financial support was provided by grants from Association Française contre les Myopathies, Université René-Descartes Paris V,

Recherche Clinique-Assistance Publique Hôpitaux de Paris (Grant CRC940116), GREG (Groupe de Recherche et d'Étude du Génome), Fondation de France, Ministère de l'Éducation Nationale, de l'Enseignement Supérieur, de la Recherche et de l'Insertion Professionnelle (ACC-SV2), Max-Planck Research Award (MLC, RT) and National Institutes of Health (AR38923).



b

binned 3p marker haplotype linked to MFS2. A slash denotes that the family member is deceased. An asterisk indicates the obligate and possible recombinants. As compared with previous reports, blood samples were collected for 10 new family members (III54, IV29, IV41, IV90, IV91, V1, V2, V3, V4 and V5) and 4 members for whom DNA samples were depleted (II10, II13, IV32, and IV53).

References

- 1 Pyeritz RE: The Marfan syndrome; in Royce PM, Steinmann B (eds): *Connective Tissue and Its Heritable Disorders. Molecular, Genetic, and Medical Aspects*. New York, Wiley-Liss 1993, pp 437-468.
- 2 Boileau C, Jondeau G, Babron M-C, Coulon M, Alexandre J-A, Sakai L, Melki J, Delorme G, Dubourg O, Bonaïti-Pellié C, Bourdarias J-P, Junien C: Autosomal dominant Marfan-like connective-tissue disorder with aortic dilation and skeletal anomalies not linked to the fibrillin genes. *Am J Hum Genet* 1993;53:46-54.
- 3 Collod G, Babron M-C, Jondeau G, Coulon M, Weissenbach J, Dubourg O, Bourdarias J-P, Bonaïti-Pellié C, Junien C, Boileau C: A second locus for Marfan syndrome maps to chromosome 3p24.2-p25. *Nat Genet* 1994;8:264-268.
- 4 Pan TC, Sasaki T, Zhang RZ, Fassler R, Timpl R, Chu ML: Structure and expression of fibulin-2, a novel extracellular matrix protein with multiple EGF-like repeats and consensus motifs for calcium binding. *J Cell Biol* 1993;123:1269-1277.
- 5 Zhang RZ, Pan TC, Zhang ZY, Mattéi M-G, Timpl R, Chu M-L: Fibulin-2 (FBLN2): Human cDNA sequence, mRNA expression, and mapping of the gene on human and mouse chromosomes. *Genomics* 1994;22:425-430.
- 6 Zhang H-Y, Chu M-L, Pan T-C, Sasaki T, Timpl R, and Ekblom P: Extracellular matrix protein fibulin-2 is expressed in the embryonic endocardial cushion tissue and is a prominent component of valves in adult heart. *Dev Biol* 1995;167:18-26.
- 7 Boileau C, Collod G, Junien C, Jondeau G, Dubourg O, Bourdarias J-P, Bonaïti-Pellié C, Frézal J, Maroteaux P: The question of heterogeneity in Marfan syndrome. *Nat Genet* 1995; 9:230-231.