



HAL
open science

Spatial Modeling of Urban Road Traffic Using Graph Theory

Kamaldeep Singh Oberoi, Géraldine del Mondo, Yohan Dupuis, Pascal Vasseur

► **To cite this version:**

Kamaldeep Singh Oberoi, Géraldine del Mondo, Yohan Dupuis, Pascal Vasseur. Spatial Modeling of Urban Road Traffic Using Graph Theory. Proceedings of Spatial Analysis and GEomatics (SAGEO) 2017, INSA de rouen, Nov 2017, Rouen, France. pp.264-277, 10.5281/zenodo.1006677 . hal-01643369

HAL Id: hal-01643369

<https://hal.science/hal-01643369v1>

Submitted on 21 Nov 2017

HAL is a multi-disciplinary open access archive for the deposit and dissemination of scientific research documents, whether they are published or not. The documents may come from teaching and research institutions in France or abroad, or from public or private research centers.

L'archive ouverte pluridisciplinaire **HAL**, est destinée au dépôt et à la diffusion de documents scientifiques de niveau recherche, publiés ou non, émanant des établissements d'enseignement et de recherche français ou étrangers, des laboratoires publics ou privés.

Spatial Modeling of Urban Road Traffic Using Graph Theory

Kamaldeep Singh Oberoi¹, Géraldine Del Mondo²,
Yohan Dupuis³, Pascal Vasseur¹

1. Normandie Univ, UNIROUEN, UNIHAVRE, INSA Rouen,
LITIS, 76000 Rouen, France

kamaldeep-singh.oberoi1@etu.univ-rouen.fr, pascal.vasseur@univ-rouen.fr

2. Normandie Univ, INSA Rouen, UNIROUEN, UNIHAVRE,
LITIS, 76000 Rouen, France

geraldine.del_mondo@insa-rouen.fr

3. CEREMA, 76121 Le Grand-Quevilly, France

yohan.dupuis@cerema.fr

RÉSUMÉ. Cet article présente un modèle qualitatif basé sur la théorie des graphes afin d'aider à la compréhension de l'évolution spatiale du trafic routier urbain. Le modèle prend en compte un certain nombre d'objets qui ont un impact sur le trafic routier et les relations entre ces objets. Les données acquises aux niveaux microscopique et macroscopique seront intégrées au modèle et l'information qualitative ajoutée à l'information quantitative a pour objectif d'améliorer la robustesse du modèle. Ce premier travail sur ce modèle met l'accent sur la description formelle du graphe à différents niveaux de granularité.

ABSTRACT. In this paper, we present a qualitative model, based on graph theory, which will help to understand the spatial evolution of urban road traffic. Various real world objects which affect the flow of traffic, and the spatial relations between them, are included in the model definition. Heterogeneous data, at microscopic and macroscopic levels, will be the input for the model, and qualitative knowledge, in addition to, quantitative data will improve its robustness. Mathematical formalization of graphs at different levels of granularity is focused on.

MOTS-CLÉS : Modèle Qualitatif, Relations Spatiales, Trafic Routier, Granularité, Théorie des Graphes, Formalization des Graphes

KEYWORDS: Qualitative Model, Spatial Relations, Road Traffic, Granularity, Graph Theory, Graph Formalization

1. Introduction

To develop intelligent transportation systems (ITS), it is necessary to understand the evolution of road traffic in space-time, as well as interactions between traffic participants and structural elements present in the environment. Most of the existing environment perception algorithms focus on either the space in the immediate vicinity of a vehicle (microscopic level) (Granström *et al.*, 2017), or consider entire road traffic as a collective entity (macroscopic level) (Li *et al.*, 2017). In order to have a "global" view of the environment, there is a need to create a model which will incorporate data gathered at different levels of detail. In addition, the perception algorithms make use of quantitative data. Although it can give precise information about the environment, enhancing it with qualitative knowledge will lead to a more robust model (Guan, 2003).

In this paper, we present a qualitative spatial model capable of providing information about the road traffic at different levels of granularity. The model uses qualitative knowledge, extracted from quantitative data, about the environment to comprehend the spatial relations between different traffic participants. It is formalized using graphs as they provide a data structure to work with abstracted real world information and have the capability to incorporate the dynamics of the road traffic (Butts, 2009). This model is envisaged to be implemented in an urban data center where all the data about the road traffic is stored, and using this data, the evolution of the road traffic is understood, and the information about other traffic participants present in its vicinity is sent to each vehicle.

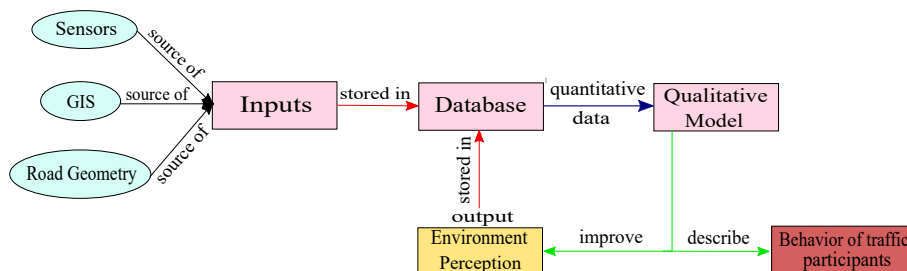

Figure 1. System block diagram

Figure 1 shows the block diagram of the global system. The data acquired from on-board/external sensors, traffic data and map data from Geographical Information Systems(GIS), knowledge about the road geometry, along with the output of the off-the-shelf environment perception algorithms is stored in the database. This quantitative data is then fed into the model and the qualitative

knowledge is extracted, using which the environment perception is improved and the spatial interaction between different traffic participants is understood.

This paper is organized as follows. Section 2 presents the previous work in this domain. Section 3 describes the qualitative spatial model along with the definitions of its constituents. In section 4 we take an in-depth look at two types of granularity present in the model. The paper is concluded in section 5 while describing the future directions for our research.

2. Related Work

In this section, we will take a look at some of the modeling techniques present in the literature. As already mentioned, the model proposed in this paper is based on graph theory. An alternative is to use probabilistic graphical models like Bayesian Networks to model the vehicle environment (Kuhnt *et al.*, 2015). These models define joint probability distribution over a set of random variables (nodes) and conditional dependencies between them (edges). Since the aim of this work is to understand the spatial relations between different physical objects, it is understandable to represent the objects as nodes and relations as edges, which is not possible with probabilistic models.

Another category of models is object oriented (or segmentation based) models (Rieken *et al.*, 2015). These models utilize the knowledge about real-world objects to understand the environment and classify them into different classes. However, they do not define spatial relations between the objects, which is an important characteristic of the proposed model. Nonetheless, this category of models has motivated us to define different object classes which are explained in a later section.

There are other graph based models which are present in the literature, as in (Ulbrich *et al.*, 2014) and (Knaup, Homeier, 2010). These models take into account the information about vehicles and road lanes, and don't consider other types of objects in the environment. Also, the definition of graphs used is not suitable to model the spatial knowledge of an urban area.

The model proposed in this article includes real world objects and spatial relations between them at microscopic and macroscopic levels, and formalizes the graphs using the general graph definition.

3. Spatial Graphical Model

In this section, we describe the qualitative spatial model. The entities and spatial relations represent the nodes and edges of the graph, respectively. We give a general description about entities and various spatial relations included in the model and then take a look at different graphical representations of the

road network. After defining some important terms, we formalize the graphs. In the end, we define different object classes present in the model.

3.1. *Entities and Spatial Relations*

For a phenomenon, an entity is an object (physical/abstract) which plays a significant role in understanding that phenomenon. Entities can have different definitions according to the type of the phenomenon and the level of abstraction (Del Mondo, 2011), (Chen, 1976). A unique identity for each entity needs to be defined to differentiate between similar entities (Hornsby, Egenhofer, 1997).

The interactions between entities are represented by spatial relations, which can be categorized into: metric, topological, and order (Egenhofer, 1989). Metric relations represent quantitative distance. However, it can be converted into qualitative distance, as explained in (Clementini *et al.*, 1997). A popular framework to understand the topological relations between two surfaces is Region Connection Calculus (RCC) (Randell *et al.*, 1992), and (Röhrig, 1994) describes the theory of order relations. In addition, orientation relations explain the relative orientation between different entities in a desired frame of reference (Freksa, 1992), whereas directional relations (Frank, 1996) are based on a general frame of reference and provide information in terms of cardinal directions.

There are other relations which are useful in case of dynamic entities. For example, (Sridhar *et al.*, 2011) mentions relative speed and relative trajectory. A method to explain relative trajectory is Directed Interval Algebra (DIA) (Renz, 2001). Extending the relation of relative speed between two objects, we define average relative speed for a set of moving objects. Since information about the road network in a given area is included in our model, we introduce two spatial relations between two road segments (formal definition of a road segment is given later), namely, accessibility relation (AR) which describes if one road segment is accessible from another using adjacency matrix (Cheng *et al.*, 2012), and relative orientation which, as the name suggests, explains the relative orientation between two connected road segments.

3.2. *Road Network Representation*

To represent road networks, two static graphs, Primal Graph and Dual Graph, are proposed in (Porta *et al.*, 2006a) and (Porta *et al.*, 2006b). In primal graph, the road segments form the edges while the intersections joining them form the nodes. Using the primal graph, the spatial structure of the road network can be explained. The dual graph, however, in which the road segments form the nodes and intersections the edges, is useful to understand the topology of the road network. These graphs augment the knowledge that the proposed model exhibits.

3.3. Definitions of the Terms Used

We define three terms which are used in the model.

– **Road segment:** A road segment R_i is the part of the road network which has two adjacent intersections I_j and I_k as its end points (figure 2). Each road segment can be divided into two bidirectional carriageways or a set of non-overlapping sectors.

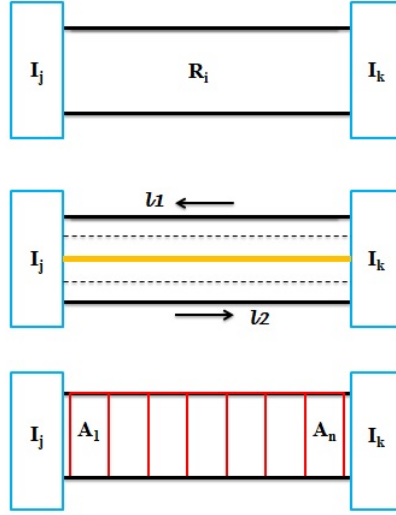

Figure 2. A road segment (top) can be divided into two carriageways (middle) or into non-overlapping sectors (bottom). The rectangular intersection blocks are merely symbolic

– **Road carriageway:** Two, single- or multi-lane, carriageways are defined to make the bi-directional nature of a road segment explicit (Kong *et al.*, 2013). In figure 2, carriageways are represented as $L = \{l1, l2\}$, where $l1$ and $l2$ are two opposite direction carriageways.

– **Road sector:** Another way to divide a road segment is into consecutive non-overlapping sectors (Kamran, Haas, 2007). This division can be on the basis of length of sectors or according to road geometry. In figure 2, set of sectors for a road segment is $A = \{A_1, \dots, A_n\}$. The number of sectors will vary depending on the level of abstraction.

3.4. Graph Formalization

In this subsection we formalize different graphs which describe the spatial knowledge from different points of view. The combination of these graphs will provide the global information about the road traffic. A graph

$$G = (X, E) \quad (1)$$

describes the spatial relations between different real-world objects in an urban environment, which are represented by the set of nodes $X = V \cup B \cup VS \cup M \cup F \cup P \cup H \cup R \cup I$. Here V is set of vehicles, B is set of buildings, VS is set of vertical structures (e.g. lane dividers, signboards, traffic signals, guard rails), M is set of road markings (e.g. zebra crossing, edge line, stop line, center line), F is set of roadsides, P is set of pedestrians, H is set of bicycles, R is the set of road segments and I is the set of intersections. The object classes in X include the objects which affect the flow of traffic in an urban area, and can be detected using existing segmentation based algorithms (Ošep *et al.*, 2016). The set of edges is given by $E = \{(x, y) \mid x \rho y\}$, $\rho \in \varrho$, $\forall x, y ((x \in V \wedge y \in X) \vee (x \in F \wedge y \in P \cup H))$ where $\varrho = \{T, O, RT, RS, QD, Ord\}$ is the set of all possible types of relations included in this graph. T is set of topological relations (RCC8), O is set of orientation relations, set RT represents relative trajectories, set RS describes the relative speed, set QD defines qualitative distance relations, and Ord defines set of order relations.

Let the number of road segments in a given urban area be N_R which is the cardinality of set R . Zooming in on a single road segment $R_i \in R$, a graph

$$G_i = (X_i, E_i) \quad (2)$$

is defined which consists of set of nodes $X_i \subseteq X \setminus (I \cup \{R_j \mid R_j \in R, j \neq i\})$, $i, j = 1, \dots, N_R$ present on R_i and the set of edges $E_i \subseteq E$ between them. Set X_i doesn't include the intersections and the road segments except R_i .

Now, this road segment $R_i \in R$ can be divided into bi-directional carriageways $l1$ and $l2$, and a two-carriageway graph

$$G_{Li} = (Y_i, E_{\omega i}) \quad (3)$$

is defined. The set of nodes of this graph $Y_i = \{V_{l1}, V_{l2}\}$ represents the groups of vehicles and the associated relations in carriageway $l1$ and $l2$, respectively. The set of edges is given as $E_{\omega i} = \{(x, y) \mid x \omega y\}$, $\omega \in \Omega$, $\forall x, y \in Y_i, x \neq y$ where $\Omega = \{T, ARS, D\}$ is the set of types of relations between the two groups. The elements of set ARS give the average relative speed between the groups and D is the set of directional relations.

If the road segment $R_i \in R$ is divided into non-overlapping sectors, a sector graph for j^{th} sector of i^{th} road segment is

$$G_{Ai(j)} = (U_{ij}, E_{ij}) \quad (4)$$

The sets of nodes and edges are given as $U_{ij} \subseteq X_i$ and $E_{ij} \subseteq E_i$ respectively, since the type of entities and relations included in $G_{A_i(j)}$ is same as in G_i . We can also assert that $G_{A_i(j)} \subseteq G_i$.

The primal and dual graphs can also be formalized mathematically. These graphs are external to the hierarchy of graphs explained so far. The primal graph is defined as

$$G_P = (I, E_\gamma) \quad (5)$$

It includes the spatial relations between two arbitrary intersections included in I . The set of edges in G_P is $E_\gamma = \{(x, y) \mid x \gamma y\}$, $\gamma \in \Gamma$, $\forall x, y \in I$, $x \neq y$ with $\Gamma = \{D\}$. A dual graph formalized as

$$G_D = (R, E_\psi) \quad (6)$$

includes spatial relations between road segments included in R . The edge set is $E_\psi = \{(x, y) \mid x \psi y\}$, $\psi \in \Psi$, $\forall x, y \in R$, $x \neq y$ where $\Psi = \{AR, RO\}$ is the set of type relations. AR represents accessibility relation and RO gives the relative orientation between two road segments.

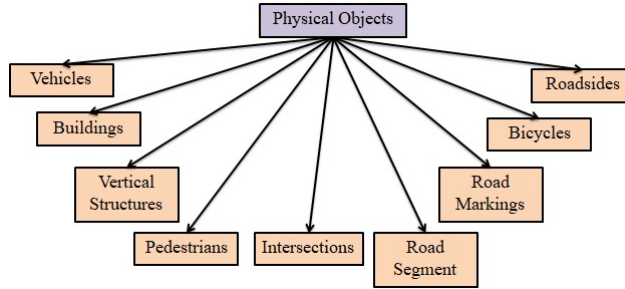

Figure 3. Classification of physical objects into classes

3.5. Thesaurus of Objects in Urban Environment

In this subsection, we will take a look at different object classes in more detail. The classification of objects into classes creates a thesaurus of objects as shown in figure 3. We consider nine different object classes present in an urban environment. Figure 4 shows different kinds of objects which can be included in these classes.

The idea behind highlighting this classification is to be able to associate a set of spatial relations to each class and, hence, reduce the number of relations required to explain different spatial interactions. Since our model is "vehicle-centric", the relations for each class represent its interactions with class "Vehicle". There are, however, two exceptions as we consider the relation between

Pedestrian-Roadside and between Bicycle-Roadside. Spatial relations for each object class are shown in table 1.

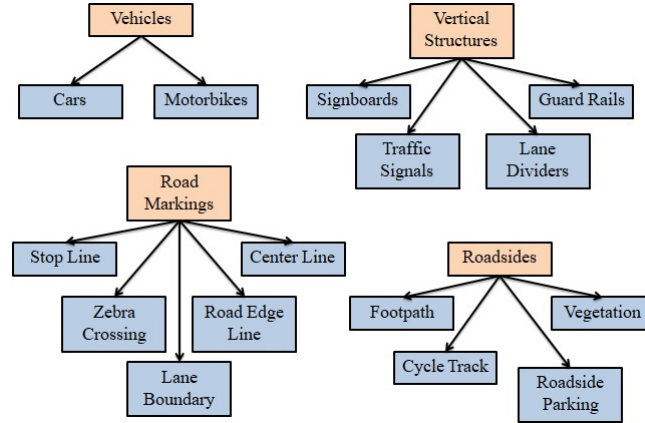

Figure 4. Types of objects in various classes

TABLE 1. Spatial relations for different object classes

Object class	Relation with class	Relations
Vehicle	Vehicle	$\{T, O, RT, RS, QD, Ord\}$
Vehicle	Building	$\{T, O, QD\}$
Vehicle	Vertical Structure	$\{T, O, QD\}$
Vehicle	Road Marking	$\{T\}$
Vehicle	Roadside	$\{T, QD\}$
Vehicle	Road segment	$\{T\}$
Vehicle	Pedestrian	$\{T, O, RT, QD\}$
Vehicle	Bicycle	$\{T, O, RT, RS, QD\}$
Vehicle	Intersection	$\{T, QD, Ord\}$
Pedestrian	Roadside	$\{T\}$
Bicycle	Roadside	$\{T\}$

4. Granularity

Granularity of a model is its ability to be explained in terms of *granules*, where finer granules are more detailed and coarser granules are more abstracted (Keet, 2006). This makes the model useful in extracting information from different points of view and focusing on only the necessary data. In the proposed model, there are two types of granularity based on the division of the road segment: Carriageway based granularity and Sector based granularity (as in (Płaczek, 2009)).

4.1. Carriageway based Granularity

When a bidirectional road segment $R_i \in R$ is divided into carriageways, a graph G_{L_i} formalizes the relations between the groups of vehicles traveling on each carriageway. This graph can be considered as granular subgraph (Stell, 1999) of G_i . Granulation, in this case, is the action of grouping together of certain nodes present at one level of detail into a single node at a lower level of detail, as the individual nodes become indistinguishable at this level (Figure 5). However, the relations between the abstracted nodes are different in G_{L_i} as compared to G_i . Figure 5 (b) shows both G_{L_i} for coarser detail and G_i for finer detail. The relations between three vehicles $V1, V2$ and $V4$ and the objects in their vicinity are included in G_i . The objects included belong to class building ($B1, B2$), roadside (Fr, Fl), road marking (center line CL), vertical structure (signboards $S1, S2$) and pedestrian ($P1, P2$).

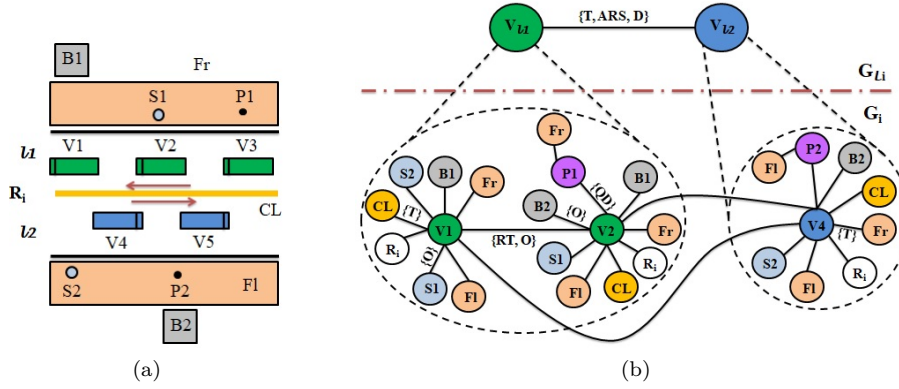

Figure 5. (a) An arbitrary road segment divided into two carriageways $l1$ and $l2$ (b) Two graphs for two levels of detail are shown. The finer graph is G_i represented from "vehicle-centric" point of view. The implementation view of this graph will have non-repetitive nodes. The coarser graph is G_{L_i} . All the relations are not shown to make the image more readable

To formalize the change in granularity from G_{L_i} to G_i , we define a relation $\delta \in T \setminus \{DC, EQ, EC, PO, TPPi, NTPPi\}$ between a vehicle $v \in V_i$, $V_i \subseteq V$ and carriageway $lk \in L$, $k = 1, 2$, which explains if the vehicle is a tangential or non-tangential proper-part (TPP or NTPP) of the carriageway (according to RCC8). V_i is the set of vehicles present over R_i and L is the set of carriageways. A bi-partite transition graph $G_T = (Y_i, V_i, \sigma_i)$ classifies each vehicle $v \in V_i$ into either of the two groups in Y_i . Here, $\sigma_i = \{(x, y) \mid y \text{ belongsTo } x\}$, $\forall x, y$ ($(x = V_{lk} \in Y_i) \wedge (y \in V_i \mid y \delta lk)$, $k = 1, 2$) is the edge set.

4.2. Sector based Granularity

When a road segment $R_i \in R$ is divided into non-overlapping sectors, a graph for k^{th} sector is given as $G_{A(k)}$. As explained in section 3.4, $G_{A(k)} \subseteq G_i$ at every level of abstraction. Figure 6 shows two levels. The level with more detail has more number of sectors and at the coarser level, these sectors are combined. It is noteworthy that the entities common between two adjacent sectors are only included in the graph when these two sectors are combined. We define a set $\lambda = \{1, \dots, M\}$ of various possible levels of abstraction, where level $j + 1$, $j \in \lambda$ is coarser than j . Set $A^j = \{A_1^j, \dots, A_n^j\}$ is the set of sectors present at level j with cardinality N_A^j . We also define a set G_A^j of graphs at this level.

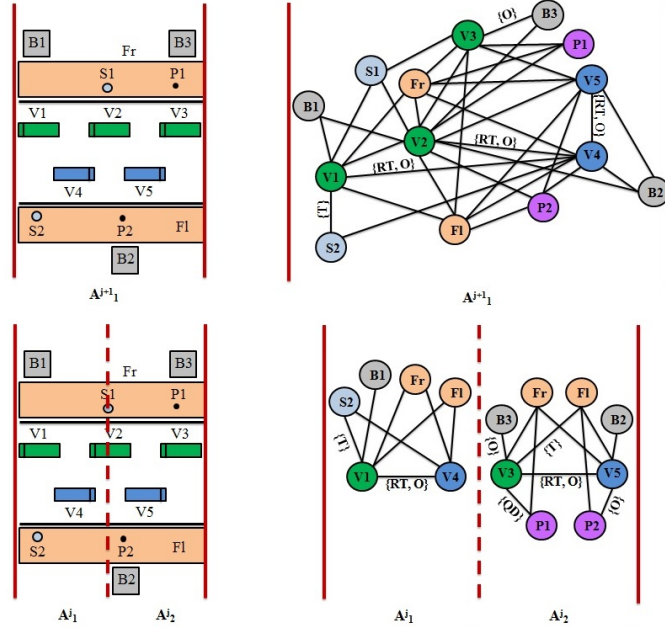

Figure 6. Two arbitrary levels of detail for sector based granularity. In this figure, the implementation view of different graphs is shown, which has single node for each entity. All relations are not shown to make the image more readable

The graphs for finer sectors are combined to form graphs for coarser sectors using Algorithm 1. It takes the set of graphs G_A^j and its cardinality N_A^j as input, and gives the set G_A^{j+1} at level $j + 1$ as output. If the cardinality is even, then the graphs at level j are combined in pairs. If the cardinality is odd and greater than three, the graphs are combined in pairs while checking the number

of uncombined graphs left. When last three graphs are left, they are combined together. This is done to avoid redundant information at two levels. If the cardinality is three, again all three graphs are combined. Using this algorithm, all the graphs at a given level are combined. However, it can be modified to combine only the desired graphs by choosing a graph index and subsequent number of graphs to be combined. Another parameter can be introduced to select the level of detail for the output graph.

Algorithm 1 : Combination of all sector graphs at level j

Data : Set of graphs at $j \in \lambda$: G_A^j , its cardinality: N_A^j

Result : Set of graphs at $j + 1$: G_A^{j+1}

```

1  $G_A^{j+1} = \emptyset$ 
2 switch  $N_A^j$  is even do
3   case true do
4     for  $k = 1$  to  $N_A^j$  do
5        $G_{A(k+1)/2}^{j+1} = G_{A(k)}^j \bullet G_{A(k+1)}^j$ 
6        $G_A^{j+1} \leftarrow G_A^{j+1} \cup \{G_{A(k+1)/2}^{j+1}\}$ 
7        $k \leftarrow k + 2$ 
8     break
9   case false do
10    if  $N_A^j > 3$  then
11       $ctr = 0$  // counter
12      for  $k = 1$  to  $N_A^j$  do
13        if  $(N_A^j - 2 * ctr) > 3$  then
14           $G_{A(k+1)/2}^{j+1} = G_{A(k)}^j \bullet G_{A(k+1)}^j$ 
15           $ctr \leftarrow ctr + 1$ 
16           $G_A^{j+1} \leftarrow G_A^{j+1} \cup \{G_{A(k+1)/2}^{j+1}\}$ 
17         $i \leftarrow i + 2$ 
18       $G_{A(ctr+1)}^{j+1} = G_{A(2*ctr+1)}^j \bullet G_{A(2*ctr+2)}^j \bullet G_{A(2*ctr+3)}^j$ 
19       $G_A^{j+1} \leftarrow G_A^{j+1} \cup \{G_{A(ctr+1)}^{j+1}\}$ 
20    else if  $N_A^j == 3$  then
21       $G_{A(1)}^{j+1} = G_{A(1)}^j \bullet G_{A(2)}^j \bullet G_{A(3)}^j$ 
22       $G_A^{j+1} \leftarrow G_A^{j+1} \cup \{G_{A(1)}^{j+1}\}$ 
23    break

```

Now, let us take a look at the graph combination operator \bullet . We define \bar{U}_k^j as the set of entities present in sector A_k at level j . However, some entities in sector A_k might be shared with adjacent sectors A_{k+1} and A_{k-1} , and such

entities are not included in graph $G_{A(k)}^j$ for A_k . Entities included in $G_{A(k)}^j$ are computed as $U_k^j = \bar{U}_k^j - \bar{U}_{k-1}^j - \bar{U}_{k+1}^j$. Similarly the edges of $G_{A(k)}^j$ are given as E_k^j . The combination of two graphs $G_{A(k)}^j$ and $G_{A(k+1)}^j$ is represented as $G_{A(m)}^{j+1} = G_{A(k)}^j \bullet G_{A(k+1)}^j$, and formalized as

$$U_m^{j+1} = U_k^j \cup U_{k+1}^j \cup (\bar{U}_k^j \cap \bar{U}_{k+1}^j), \quad E_m^{j+1} = E_k^j \cup E_{k+1}^j \cup \{(x, y) \mid x \mathcal{R} y\},$$

$$\forall x, y (x \in U_k^j \wedge y \in U_{k+1}^j \cup (\bar{U}_k^j \cap \bar{U}_{k+1}^j)) \vee \quad (7)$$

$$(x \in U_{k+1}^j \wedge y \in U_k^j \cup (\bar{U}_k^j \cap \bar{U}_{k+1}^j)) \vee \quad (8)$$

$$(x \in (\bar{U}_k^j \cap \bar{U}_{k+1}^j) \wedge y \in (U_k^j \cup U_{k+1}^j)) \quad (9)$$

to get the graph $G_{A(m)}^{j+1} = (U_m^{j+1}, E_m^{j+1})$ at level $j + 1$ for a sector m . \mathcal{R} is a general representation of a relation between x and y . It is noteworthy that operation $G_{A(m)}^{j+1} = G_{A(k)}^j \bullet G_{A(k+1)}^j$ is associative and commutative.

Complexity of the algorithm depends on the complexity of the operation of combining graphs, which in turn depends on the complexity of formation of new edges with $\{(x, y) \mid x \mathcal{R} y\}$. Properties (7), (8) and (9) describe three ways in which the elements x and y can be chosen to form new edges. Hence the complexity of \bullet operation is $O(p * q)$, where p and q are the cardinalities of the sets which contain x and y in (7), (8) and (9). It can, however, be improved by utilizing the knowledge of object classes and the corresponding relations listed in Table 1.

5. Conclusion and Future Work

In this paper, we present our initial ideas to develop a spatial model to understand the urban road traffic using heterogeneous data available at different levels of detail. We formalized various graphs which include different types of entities and relations. We also present the idea of categorizing the real-world objects into various classes and associate a specific set of spatial relations to each class. We propose two types of granularity: carriageway-based and sector-based. In former, the level of detail is shifted using transition graph. And in latter, the graph combination operator to shift from finer to coarser graphs is presented.

In future, the combination of sector graphs will be improved in terms of complexity and usability, and a separate algorithm to shift from coarser to finer detail will be proposed. Some criteria to segregate real road segments into sectors will be also be defined. Since road traffic is dynamic, we want to expand our model by including the temporal information. Also a dynamic graph focused on an arbitrary intersection needs to be proposed to comprehend the flow of traffic at that intersection. For the implementation of the model, we will use the traffic and perception data collected by CEREMA for the city of Rouen, France, along with map data from services like OpenStreetMaps.

Acknowledgements

This work takes part in the DAISI project. This project has been funded with the support from the European Union with the European Regional Development Fund (ERDF) and from the Regional Council of Normandy.

Bibliographie

- Butts C. T. (2009). Revisiting the foundations of network analysis. *science*, vol. 325, n° 5939, p. 414–416.
- Chen P. P.-S. (1976). The entity-relationship model—toward a unified view of data. *ACM Transactions on Database Systems*, vol. 1, n° 1, p. 9–36.
- Cheng T., Haworth J., Wang J. (2012). Spatio-temporal autocorrelation of road network data. *Journal of Geographical Systems*, vol. 14, n° 4, p. 389–413.
- Clementini E., Di Felice P., Hernández D. (1997). Qualitative representation of positional information. *Artificial intelligence*, vol. 95, n° 2, p. 317–356.
- Del Mondo G. (2011). *A Spatio-Temporal Graph-based Model for the Evolution of Geographical Entities*. Theses, Université de Bretagne occidentale - Brest.
- Egenhofer M. J. (1989). A formal definition of binary topological relationships. In *International conference on foundations of data organization and algorithms*, p. 457–472.
- Frank A. U. (1996). Qualitative spatial reasoning: Cardinal directions as an example. *International Journal of Geographical Information Science*, vol. 10, n° 3, p. 269–290.
- Freksa C. (1992). Using orientation information for qualitative spatial reasoning. In *Theories and methods of spatio-temporal reasoning in geographic space*, vol. 639, p. 162–178. Springer, Berlin.
- Granström K., Renter S., Fatemi M., Svensson L. (2017, June). Pedestrian tracking using velodyne data - stochastic optimization for extended object tracking. In *2017 IEEE Intelligent Vehicles Symposium (IV)*, p. 39–46.
- Guan W. (2003, Oct). Modeling traffic flow characteristics with qualitative and quantitative knowledge. In *Proc. IEEE International Conference on Intelligent Transportation Systems*, vol. 1, p. 151–155.
- Hornsby K., Egenhofer M. J. (1997). Qualitative representation of change. In *International conference on spatial information theory*, p. 15–33.
- Kamran S., Haas O. (2007). A multilevel traffic incidents detection approach: Identifying traffic patterns and vehicle behaviours using real-time GPS data. In *Intelligent Vehicles Symposium, 2007 IEEE*, p. 912–917.
- Keet C. M. (2006, May). A taxonomy of types of granularity. In *IEEE International Conference on Granular Computing*, p. 106–111.
- Knaup J., Homeier K. (2010). Roadgraph-graph based environmental modelling and function independent situation analysis for driver assistance systems. In *Intelligent*

- transportation systems (itsc)*, 2010 13th international ieee conference on, p. 428–432.
- Kong Q.-J., Zhao Q., Wei C., Liu Y. (2013). Efficient traffic state estimation for large-scale urban road networks. *IEEE Transactions on Intelligent Transportation Systems*, vol. 14, n° 1, p. 398–407.
- Kuhnt F., Kohlhaas R., Schamm T., Zöllner J. M. (2015). Towards a unified traffic situation estimation model—street-dependent behaviour and motion models. In *Information fusion (fusion)*, 2015 18th international conference on, p. 1223–1229.
- Li W., Nie D., Wilkie D., Lin M. C. (2017, Fall). Citywide estimation of traffic dynamics via sparse gps traces. *IEEE Intelligent Transportation Systems Magazine*, vol. 9, n° 3, p. 100–113.
- Ošep A., Hermans A., Engelmann F., Klostermann D., Mathias M., Leibe B. (2016). Multi-scale object candidates for generic object tracking in street scenes. In *Robotics and automation (icra)*, 2016 ieee international conference on, p. 3180–3187.
- Plączek B. (2009). The granular computing implementation for road traffic video-detector sampling rate finding. *Transport Problems*, vol. 4, p. 55–62.
- Porta S., Crucitti P., Latora V. (2006a). The network analysis of urban streets: a dual approach. *Physica A: Statistical Mechanics and its Applications*, vol. 369, n° 2, p. 853–866.
- Porta S., Crucitti P., Latora V. (2006b). The network analysis of urban streets: a primal approach. *Environment and Planning B: planning and design*, vol. 33, n° 5, p. 705–725.
- Randell D. A., Cui Z., Cohn A. G. (1992). A spatial logic based on regions and connection. In *Proceedings of the third international conference on principles of knowledge representation and reasoning*, vol. 92, p. 165–176.
- Renz J. (2001). A spatial odyssey of the interval algebra: 1. directed intervals. In *Proceedings of the 17th international joint conference on artificial intelligence - volume 1*, p. 51–56. Morgan Kaufmann Publishers Inc.
- Rieken J., Matthaei R., Maurer M. (2015). Toward perception-driven urban environment modeling for automated road vehicles. In *Intelligent transportation systems (itsc)*, 2015 ieee 18th international conference on, p. 731–738.
- Röhrig R. (1994). A theory for qualitative spatial reasoning based on order relations. In *Proceedings of the twelfth national conference on artificial intelligence (vol. 2)*, p. 1418–1423. American Association for Artificial Intelligence.
- Sridhar M., Cohn A. G., Hogg D. C. (2011). Benchmarking qualitative spatial calculi for video activity analysis. In *Proceedings ijcai workshop benchmarks and applications of spatial reasoning*, p. 15–20.
- Stell J. G. (1999). Granulation for graphs. In *International conference on spatial information theory*, p. 417–432.
- Ulbrich S., Nothdurft T., Maurer M., Hecker P. (2014). Graph-based context representation, environment modeling and information aggregation for automated driving. In *Intelligent vehicles symposium proceedings, 2014 ieee*, p. 541–547.