



HAL
open science

Conflict Investigation between Thermal Comfort and Fire Safety in Naturally Ventilated Building Located in Tropical and Hot Climate.

Karim Khan Juhoor, Laurent Lemaitre, Maxime Boulinguez, Alain Bastide

► **To cite this version:**

Karim Khan Juhoor, Laurent Lemaitre, Maxime Boulinguez, Alain Bastide. Conflict Investigation between Thermal Comfort and Fire Safety in Naturally Ventilated Building Located in Tropical and Hot Climate.. 2017. hal-01629293

HAL Id: hal-01629293

<https://hal.science/hal-01629293>

Preprint submitted on 6 Nov 2017

HAL is a multi-disciplinary open access archive for the deposit and dissemination of scientific research documents, whether they are published or not. The documents may come from teaching and research institutions in France or abroad, or from public or private research centers.

L'archive ouverte pluridisciplinaire **HAL**, est destinée au dépôt et à la diffusion de documents scientifiques de niveau recherche, publiés ou non, émanant des établissements d'enseignement et de recherche français ou étrangers, des laboratoires publics ou privés.

Conflict Investigation between Thermal Comfort and Fire Safety in Naturally Ventilated Building Located in Tropical and Hot Climate.

Karim Khan JUHOOR^{*a, b}, L.LEMAITRE ^a, M.BOULINGUEZ ^a, A. BASTIDE ^b

^a *Intégrale Ingénierie, fire safety and sustainable construction department, Reunion Island, France*

^b *PIMENT Laboratory ; 117 Avenue du Général Ailleret 97430 Le Tampon, France*

**Corresponding author. Intégrale Ingénierie 14 rue Jules Thirel, Savannah, 97460 Saint-Paul. TEL : +262 262 24 59 63.*

E-Mail address : karim.juhoor@univ-reunion.fr

This article must be read in colored version.

Abstract

Safety performance is one of the most important considerations in building design. Moreover, new environmental building design allows construction to have a sustainable relationship with the outdoor climate, especially in tropical context. This paper aims at evaluating how conception that allows natural ventilation by mean of passive strategies, affects fire safety performance in buildings. A methodology, combining safety and comfort through a global index, is proposed in order to understand how the consideration of fire safety can affect initial passive design. The use of dynamic thermal simulation associated with fire simulation gives the opportunity to quantify fire performance annually. Sensitivity analysis is performed by using delta moment index. This allows to evaluate the absolute impact of input parameter on both fire safety and thermal comfort outputs. A refined study is then performed by the use of conditional output distribution. It takes into account the relative importance given to fire Safety or thermal comfort concerns. The strong dependence of fire safety, in terms of smoke extraction, on weather conditions, building orientation, occupation profiles and seasons, is demonstrated in naturally ventilated buildings.

28

29 **Keywords:**

30

31 Fire safety, Thermal Comfort, Smoke extraction, Natural ventilation, Critical Safety Period,

32 Safety design, Hot Climate, Tropical Climate.

33

34 **1. Introduction**

35 Insular areas are impacted by energy supply constraints, affect both directly and

36 indirectly the building sector. In Reunion Island, the overall consumption due to

37 construction represents more than 45 % of the overall electric energy consumption [1].

38 Knowing that Reunion Island aims at being autonomous in terms of energy supply by

39 2030, one could not achieve this goal without thinking about how to build better, in a

40 sustainable way. New construction should hence provide free running building that

41 combine passive design, acceptable thermal comfort, energy efficiency, and last but not

42 least, a high level of safety. Two questions are then arisen: How to integrate safety

43 consideration into passive design process? And why is it important to associate comfort

44 and fire safety?

45

46 Firstly, it is important to highlight how safety and comfort is commonly covered in

47 Reunion Island. Concerning fire safety, the same standard is prescribed in Reunion as in

48 mainland France. Hence, standards for fire safety is mostly prescriptive [2]–[5]. In others

49 terms, in each situation related with safety, systems and solutions are imposed contrary

50 to objective standards, which are based both on factual measurements and the setting of

51 safety performance goals. These standards are, for most of them, designed for closed

52 building with mechanical air supply and conditioning system. In the case of the extraction

53 of toxic smoke during a fire event, both natural and mechanical exhaust is prescribed by

54 the building regulation. For inlet and outlet related to the extraction of fire smoke, rules
55 are given in terms of dimensions, distances, as well as numbers of openings. Fan
56 characteristics are also given in order to satisfy the standards' requirements. However,
57 the impact of passive ventilation strategies on fire safety design is not taken into account.
58 This is where issues meet. The wind is variable and fluctuate by nature, then natural
59 smoke extraction potential has to be quantify depending on wind variation and building
60 characteristics. This is not the case in French fire regulation.

61

62 Some research has payed attention to the issue of natural exhaust of smoke for building
63 under natural ventilation [6]–[8] and outlined the importance of uncertainties of the
64 hypothesis when calculating physical quantities related to fire smoke. Salem [9] gives a
65 sense of what could be the impact of uncertainties on the Available Safe Egress Time
66 (ASET) defined by the standard ISO/TR 16738 [10].The ASET is the time when integrity
67 of occupant is compromised during a fire event ; while the Required Safe Egress Time
68 (RSET), also presented in ISO/TR 16738, is the amount of time required to get out of the
69 building. ASET takes into account toxic and irritating gas as well as radiant and convective
70 temperature effects on Human bodies by setting thresholds. Another study proposed by
71 Kong [11] specifies that uncertainties should not be neglected while elaborating fire
72 scenarios using fire models. Allard et al. [12]evaluate different parameters, including fire
73 characteristic, that most impact the risks associated to fire using the CFAST [13] software.
74 This is one of the multiple cases where fire safety and environmental design are dealt with
75 separately despite of the relation that exits between them [14]. Thermal comfort is subject
76 to a large number of studies [15], [16]. Several models exist to assess indoor thermal
77 comfort such as analytical models and field models. Fanger [17] introduced Predicted
78 Mean Vote (PMV) in order to evaluate comfort in controlled environments. Climatic

79 diagram [18] and adaptive thermal comfort [19]–[21] model have been developed for
80 naturally ventilated buildings. Sensitivity analyses have been conducted in order to
81 evaluate the parameters that most affect thermal comfort and energy consumption for
82 energy simulation model [22]–[25]. However, literature review shows a lack of studies
83 combining fire safety and thermal comfort targets, especially for naturally ventilated
84 room in tropical climate.

85 This study focuses on the effect of the weather as well as the effect of initial design on
86 thermal comfort and fire safety for a naturally ventilated building. Moreover, an
87 investigation on potential conflicts between the two considerations is led. A combined
88 index approach, with a disjunction connective function, is proposed using delta moment
89 measures [26]. Four climate zones, two occupation types, and four building types are
90 considered. One of the objective is to discuss the impact of fire on smoke exhaust
91 performance in naturally ventilated buildings. Another objective is to discuss on the
92 existence of conflicting parameters for comfort and safety. By definition, a contentious
93 parameter has a relative significant impact on both safety and comfort index, but its
94 impact is negative for the one and positive for the other one [14].

95
96 In order to assess thermal comfort, the extended Givoni's zone proposed by Lenoir is
97 considered. Available Safe Egress Time, by means of Fractional Effective Dose related to
98 toxic gases, as well as Critical Velocity, as defined by Chen et al. [27], are chosen as a fire
99 safety performance measures.

100 Moreover, another fire safety measure is introduced under the name of Critical Safety
101 Period (CSP). It corresponds to the percentage of time when windy condition can
102 significantly affect smoke extraction. The CSP hence depends of the wind conditions, the
103 orientation of the building, as well as the opening location. The emphasis on passive

104 design interaction with fire safety level is demonstrated. In addition, conditional
105 distribution of the output allows to underscore conflicting parameters by considering
106 uncertainty and setting scenarios. According to [28], The study of output distribution
107 allows analysts to measure the inputs' influence on given model outputs.

108

109 **2. Why integrating fire safety in passive design?**

110

111 Inlet and outlet position in naturally ventilated room has been studied by Tominaga and
112 Blocken [28]. They made wind tunnel experiment in order to assess the impact of opening
113 position on flow dispersion. They conclude on the fact that inlet position has a strong
114 impact on contaminant dispersion in naturally cross ventilated buildings. Moreover,
115 depending on the configurations of the openings studied, flow rates varied within a range
116 of 40 %. It is obvious that inlet and outlet position have a strong impact on thermal
117 comfort measures, based on climatic chart, in tropical area since air change rate is one of
118 the most impacting parameter [14]. Now, thinking about smoke extraction, one can ask if
119 the same opening configuration will be positive for both thermal comfort and smoke
120 extraction efficiency, knowing that safety during a fire event depends on where the flow
121 is coming in [27]. Smoke extraction and its impact on a building should be introduced.

122

123 A suitable definition of smoke can be find in the (National Fire Protection Association)
124 handbook whereby "smoke is defined as airborne solids and liquid particulates and gases
125 evolved when material undergoes pyrolysis or combustion, together with the quantity of
126 air that is entrained or otherwise mixed into mass"[31]. Since the seventies, fire plume
127 and smoke has been widely studied [32]–[35]. In order to understand fire smoke, Nelsen
128 and Klote present several phenomenon that occurs during fire event [36]. According to

129 [36] when smoke is produced, it is cooled down: by surrounding air, by thermal exchange
130 with surrounding solid material and by radiant energy lost. As soon as the smoke is cooled
131 down, the same behaviour of a pollutant can be observed. Different forces will impact the
132 smoke movement. The first one is the thermal buoyancy, created by temperature and
133 density difference between the fire smoke and surrounding air. The second main force
134 that can affect smoke movement is wind force [7], [8], [27]. Moreover, another factor that
135 can act on smoke displacement is pressure force caused by mechanical ventilation system
136 [37], [38]. It has been proved that smoke extraction, management and control can have a
137 significant impact on the safety level of a building and on the preservation of human lives
138 [39]. SFPE guide pinpoints the fact that during a fire, tenability conditions are compromised
139 by the exposure of radiant and convective heat, inhalation of toxic gases and obscuration
140 caused by smoke [40]. A suitable system of fire smoke control is one of the driving factors
141 that can lead to high safety performance. Identification of physical quantities such as
142 interface height, smoke layer temperature, and mass flow rate through openings, is crucial
143 for quantifying the risk. Hence, the difference between fire-induced smoke and isothermal
144 contaminant dispersion study is the strong presence of thermal forces which is one of the
145 two main driving forces of natural ventilation [41]. This makes wind tunnel analysis not
146 adapted to quantify the effect of window position on smoke extraction in naturally
147 ventilated spaces. Some research has been conducted in order to characterize the effect
148 of wind on smoke extraction depending on dual window position. For example, Chen et
149 al. introduced wind effect on smoke extraction by considering Bernoulli's approach [27]
150 with a fully mixed indoor ambience. They demonstrate the existence of a critical velocity
151 which appears when the top opening is windward and the bottom opening is leeward.
152 Critical Velocity is the wind velocity at which smoke does not extract through the windward
153 façade when wind force opposes buoyancy. In this case wind opposes buoyancy and . Yi

154 et al. [7] also studied wind impact on smoke extraction considering two zone indoor
155 ambiance and roof outlet. They concluded on the influence of net wind pressure
156 coefficient value on the smoke extraction performance.

157 In addition, a series of reduced scale experiments have confirmed, by means of
158 observation, the existence of a critical velocity when wind opposed buoyancy. The
159 experimentation is based on Tominaga and Blocken [28] setup. The chosen geometry
160 represents a generic isolated building with two opposite asymmetric openings placed
161 respectively in the windward and leeward façade. The chosen geometry in one of the five
162 geometry tested by Tominaga and Blocken [28]. The geometry under study has a top
163 opening on the windward façade and a bottom opening in the leeward one and represents
164 one of the most efficient configuration in terms of passive pollutant dissipation and net
165 flow rate according to Tominaga and Blocken [28] study. In order to reproduce the effect
166 of hot fire smoke, helium is used based on Vauquelin et al. study [42]. The results, in terms
167 of critical velocity observation is presented in Figure 1.

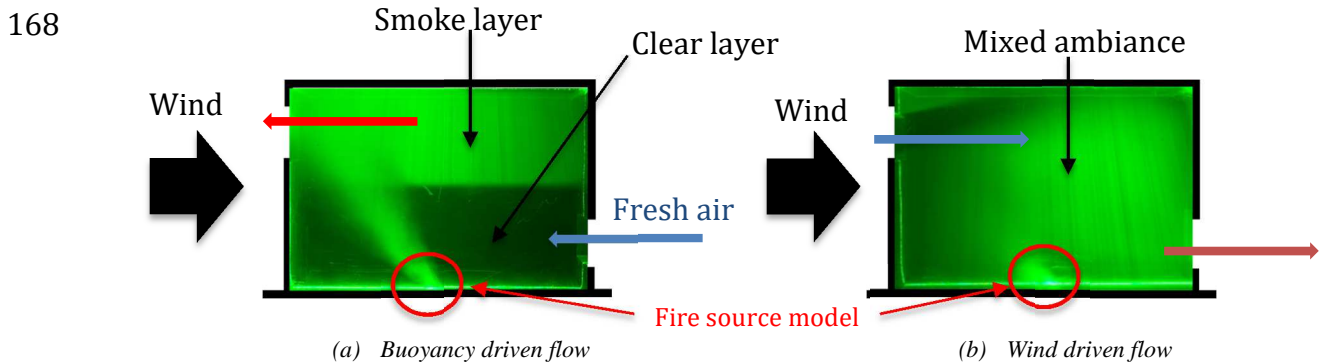

169 *Figure 1: Observation of critical velocity on a reduced scale experiment set up in IUSTI Laboratory, for a simple geometry*
170 *with top opening facing the wind and buoyant injection in the middle of the room. (a) represents typical pattern for a*
171 *buoyancy dominated flow while (b) shows flow pattern for a wind dominated flow when critical velocity is exceed.*

172 All these study shows that wind as both a strong impact on safety level as well as on air
173 quality and comfort. Then it should be necessary:

- 174 • on the first hand, to consider fire safety level as a function of time and depending on
175 climatic conditions, and
- 176 • on the other hand, to approach the interaction that could exist between sustainable
177 and safety design.

178 These two points, will surely lead to a better approach when designing or retrofitting a
179 building in a sustainable way for both tropical areas and areas where natural ventilation
180 can be used as passive strategy. Hence, the presented study is held is four steps:

- 181 • **Step 1** consists in evaluating most impacting parameters for fire safety alone when
182 natural ventilation operates, using CFAST.
- 183 • **Step 2** consists in combining measures while evaluating the model using sensitivity
184 analysis and disjunction connective function.
- 185 • **Step 3** is relative to the optimisation using Kernel Density Estimator (KDE) and the
186 use of weighing coefficient.
- 187 • **Step 4** consists in the research of contentious input parameter, using weighing
188 coefficient.

189 One of the best way to integrate fire safety in the early sustainable design is to use the
190 same reflexion as in [27]. Critical Velocity appears when top opening is windward and
191 bottom opening is leeward (Figure 1). It is hence necessary to estimate the amount of time
192 when top opening will be windward thanks to the weather file of a given location and
193 especially the wind rose. This amount of time when critical velocity can appear is called
194 here the Critical Safety Period. The more the CSP will be long during the year, the less
195 safety level will be regarding smoke extraction performance. In this study the CSP and
196 Critical velocity will be used as safety measures. The dependence of safety level on the
197 location will be then demonstrated. All buildings performance measures for both comfort
198 and safety are presented in the next part.

199

200 3. Building performance measures

201 3.1. Thermal comfort measures

202 The Lenoir extended Givoni's zone is chosen here as a comfort index. The objective here
203 is to show how comfort and safety can interact.

204

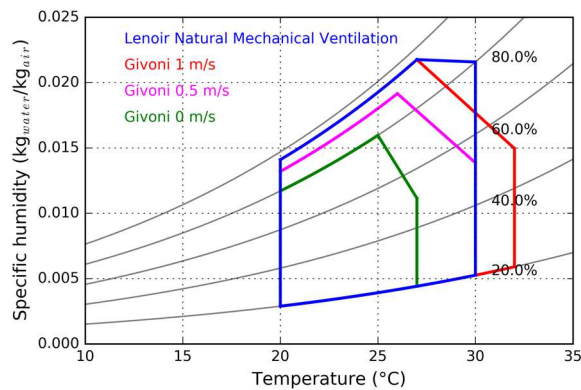

205

206 *Figure 2: Givoni's and lenoir's zones represented on climate chart*

207 Hence, for this study the extended Givoni's zone proposed by Lenoir [43] is chosen. The
208 percentage of point within the studied zone, for a given period of simulation, represents
209 the measures of comfort knowing that a point correspond to an indoor dry bulb
210 temperature as well as an indoor relative humidity at a given hour of time (Figure 2). This
211 data is given by dynamics thermal simulations. The chosen thermal comfort measure is
212 normalized, the objective for each case is to reach unity. This measure is named as C_{NMV} .

213

214 3.2. Fire safety performance measures

215 In order to enhance safety level, in accordance with the Available Safe Egress Time
216 (ASET), people have to exit the building as rapidly as possible in the best conditions. In
217 order to achieve such a goal, fire smoke should be defined and quantify the best way as
218 possible. Different type of study can be done to understand the fire smoke impact during

219 fire event. Three types of analyses exist: A reduced scale analyse using scale model [44]–
220 [46], real scale model analyses [7], [37], [38], [47], [48], and numerical simulation using
221 zone model or computational fluid dynamics [49]–[53]. Zone model is used here to
222 identify the quantities that most affect safety measures. Four main fire safety measures
223 will be consider into this article: the Critical Safety Period (CSP), The Fractional Effective
224 Dose of toxic gas [54], the critical velocity, and the same safety index used in [14] based
225 on Allard et al. work [12].

226

227 3.3. Critical Safety Period measure (CSP)

228 This measure represents the percentage of the time when top inlet is located in the
229 windward part of the building. It hence. Considering a simple volume with wind pressure
230 coefficient on both site as in Figure 3, CSP is when $Cp1 - Cp2 > 0$.

231

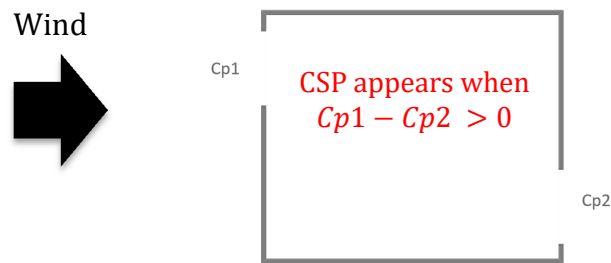

232

233

Figure 3: Description of CSP condition

234 With Cp_i the wind pressure coefficient of the façade i . Then the fraction of time outside of
235 the CSP during the studied period represents the CSP measure S_{SCP} . In other terms
236 favourable wind condition to smoke extraction is considered. If $S_{SCP} = 1$ then there is no
237 CSP. If $S_{SCP} = 0$, we are always under CSP.

238

239 3.4. Critical Velocity measure

240 The critical velocity measure is based on the correlation proposed by [27]. This
241 correlation is defined as follow (1):

$$V_{cr} = \sqrt{\frac{2 \left(1 - \frac{T_a}{T_g}\right) gh}{\Delta C_p}} \quad (1)$$

243
244 With T_a : the outdoor air temperature, T_g : the mixed indoor air temperature, g : the
245 gravitational constant, h : the height difference between top opening and bottom opening
246 and $\Delta C_p = C_{pW} - C_{pL}$. C_{pW} is the wind pressure coefficient on the windward facade and
247 C_{pL} is the wind pressure coefficient on the leeward facade. The critical velocity index S_{VC}
248 is then defined as the ratio of time, within the CSP, when wind speed is inferior to the
249 Critical Velocity (1). The objective for this measure is to be close to unity. The S_{VC} measure
250 is only evaluated within the CSP.

251

252 **3.5. FED measure**

253 Fractional Effective Dose (FED) for toxic gas is calculated according to the standards
254 ISO/TR 16738. Toxic gas concentration can then be calculated with the following equation
255 (2):

256

$$X_{FED} = \sum_{i=1}^n \sum_{t_1}^{t_2} \frac{1}{t_i} \cdot \Delta t \quad (2)$$

257

258 With t_i the time when tenability is compromised due to the toxic component i . and Δt the
259 time step. The aim here is to calculate FED for carbon monoxide and carbon dioxide which
260 are the two main toxic gas during a fire event. Then global FED is estimated as follow (3):

$$FED_{toxicity} = (FED_{CO} + FED_{O_2}) \times V_{CO_2} \quad (3)$$

261 V_{CO_2} is the over ventilation correction which depends on the CO_2 fraction. The expression
262 of V_{CO_2} is presented in (4)

$$V_{CO_2} = \frac{\exp(0,1903 \times \%CO_2 + 2,0004)}{7,1} \quad (4)$$

263 The safety measure S_{FED} is then equal to the percentage of simulated period during when
264 the tenability is not compromised. Tenability is considered as compromised when X_{FED} is
265 up to a fixed threshold given by the standards ISO/TR 16738. The threshold is set here to
266 0.3 that correspond to a limit at which 11.4% of the people, affected by fire conditions,
267 will not able to egress. The aim for S_{FED} is also to be near to unity.

268

269 **4. Climates description and chosen micro-climate.**

270

271 Reunion Island (21°16'10.1"S ; 55°30'23.5"E) can be divided into four climate zone
272 according to the PERENE local green buildings guideline [55]. As a consequence Reunion
273 Island can clearly help in order to evaluate microclimate impact on thermal comfort in
274 naturally ventilated room.

275

276

277

278

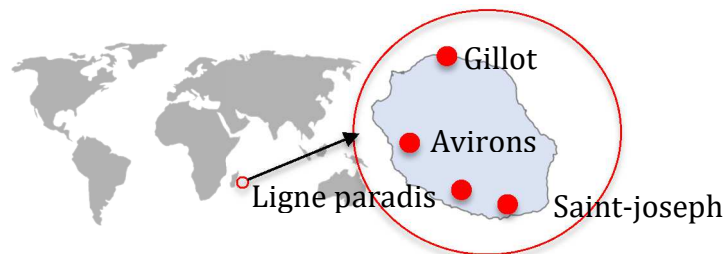

Figure 4: Location of the study

279 Low land of Reunion Island is the most appropriate places to build passive building
 280 enhancing natural ventilation. This is the reason why all weather for this study is located
 281 in this area (Figure 4). To appreciate environmental conditions for each chosen weather
 282 file, relative humidity and dry bulb temperature are plotted on the climatic diagram. In
 283 most of cases outdoor conditions is suitable in order to reach thermal comfort conditions
 284 according to Givoni's and Lenoir's zones (Figure 5).

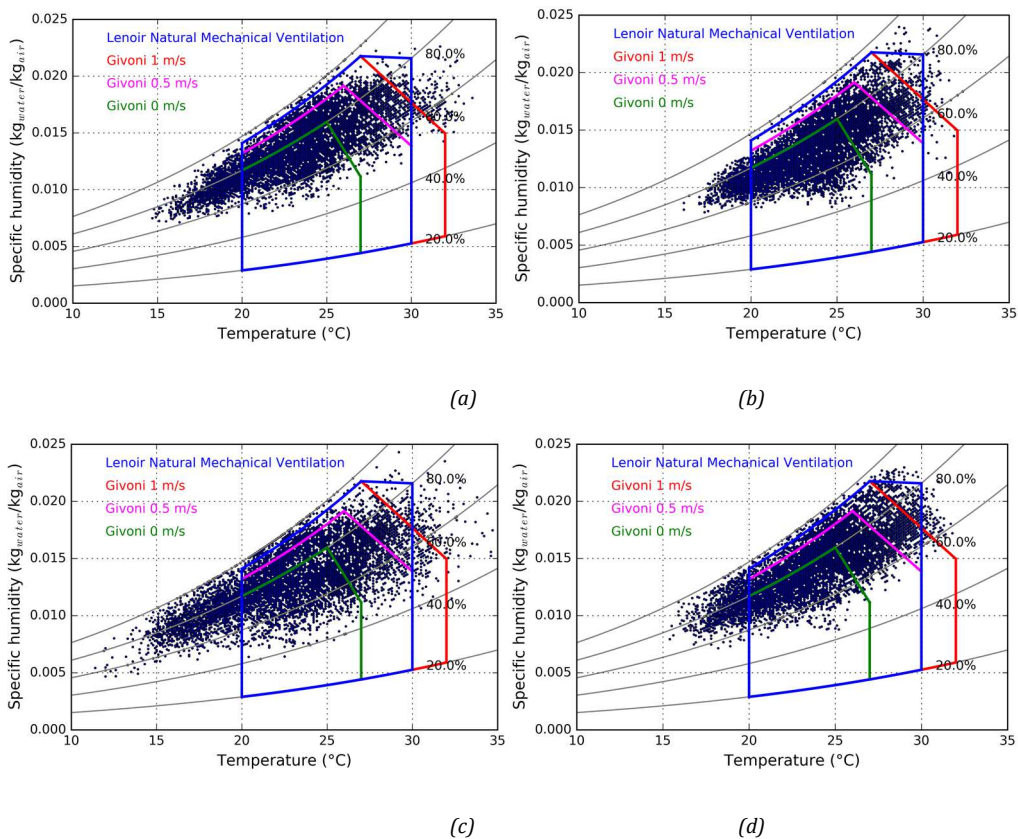

Figure 5: Climatic diagram representing Givoni's and Lenoir Zone for four different location in Reunion Island (a) Avirons (b) Gillot (c) Ligne-Paradis (d) Saint-Joseph

291 According to Figure 5, relative humidity varies in most of the case from 40 % to 95%.
 292 Ligne-Paradis is the place with the most extreme temperature whereas Gillot's points is
 293 more "compacted". It will hence be interesting to evaluate if the four location will have a
 294 significant impact on thermal comfort measures.

295

296 5. Building model for fire and energy

297 Building simulation models can be divided into three categories: zone models, multizone
298 network models, based on nodal approach, and field models. The nodal approach is widely
299 used in building simulation, for both energy and fire models. Nodal models are based on
300 the assumption that zone air temperature, contaminant concentrations and other
301 physical quantities are uniform, and represented by a node.

302

303 This assumption, which allows to obtain results without high computational cost, can be
304 discussed in terms of precision. For both fire and advanced thermal models, the studied
305 zone can be divided into two or more nodes (zones) in order to estimate smoke layer or
306 thermal stratification. These models are also known as zone models. Multizone network
307 models allow to connect multiple ambiances, represented by nodes, so as to measure the
308 different exchanges that exist between them. Hence, low computational cost and the
309 modelling procedure allow to easily integrate physical phenomena, which can provide
310 new opportunities not only in fire but also in energy research. The CFAST software [13],
311 developed by the NIST (Peacock et al., 2013), allows performing fire simulations so as to
312 assess safety level. CFAST is a two-zone model used to evaluate smoke, species and gas
313 distribution resulting from a fire. The model can also calculate the layers temperatures
314 distribution with respect to the time in the upper and lower layers. CFAST model is based
315 on a set of ordinary differential equations derived from the fundamental laws of mass and
316 energy conservation. Moreover FED and zone temperatures can be calculated with CFAST.

317

318 Performing whole building energy and thermal simulation, EnergyPlus is capable of
319 simulating thermal building behaviour over a full year, using a weather data file and the
320 building characteristics. Moreover, it allows to estimate pressure coefficient on each
321 façade according to Swami and Chandra correlation. Hence, this tool allows designing

322 complex ventilation network, considering passive design and natural ventilation. In order
 323 to quantify thermal comfort, Critical Safety Period and ASET, the combination of
 324 EnergyPlus and CFAST is relevant for this study. Therefore, in the case studied, if referring
 325 to equation (1), T_a is given with the weather file hour by hour, T_g is calculated thanks to
 326 CFAST at mid time of fire event. T_g is then equal to the mean temperature between upper
 327 and lower layers weighed by each layer volume. Finally, ΔC_p is calculated thanks to
 328 EnergyPlus software.

329

330 **6. Sensitivity analysis**

331 By definition, a sensitivity analysis is global when, on one hand, parameters vary
 332 simultaneously and, on the other hand, sensitivity is measured on the overall space of
 333 each parameter [56]. Various indicator families exist in order to measure the impact of
 334 uncertainties on a given model. For this study, the delta moment of Borgonovo is used
 335 [28]. The delta moment importance measures is given as follow (5):

$$\delta_i = \frac{1}{2} E_{X_i} [s(X_i)] \quad (5)$$

336 Where:

337 δ_i is the uncertainty importance of input X_i ;

$$338 \quad s(X_i) = \int |f_Y(y) - f_{Y|X_i}(y)| dy ;$$

$$339 \quad E_{X_i} [s(X_i)] = \int f_{X_i}(x_i) [\int |f_Y(y) - f_{Y|X_i}(y)| dy] dx ;$$

340 Where $f_{X_i}(x_i)$ is the density of X_i .

341 In other term $s(X_i)$ represents the output distribution shift when X_i .is fixed to one of its
 342 possible values. $s(X_i)$ indicates how the view of the decision maker on output distribution
 343 will change when X_i is fixed to a known value. When fixed X_i value changes the output
 344 distribution significantly, then the parameters can be registered among the relevant ones.

345 At the contrary, if fixing X_i does not change significantly Y distribution, parameters is
346 considered not impacting.

347 Another measure is also given by δ_{ij} . This measure allows to identify the impact of groups
348 of two parameters on model output. The measure is defined as follow (6):

$$\delta_{ij} = \frac{1}{2} E_{X_i, X_j} [s(X_i, X_j)] \quad (6)$$

349 Where:

$$s(X_i, X_j) = \int |f_Y(y) - f_{Y|X_i, X_j}(y)| dy \quad (7)$$

350 This study will use sensitivity analysis as a mean of understanding the relationship
351 between smoke extraction during a fire event and thermal comfort. Firstly, sensitivity
352 analysis will focus on smoke extraction performance using CFAST, in order to analyse the
353 influence of inlet position and Window to Wall Ratio (WWR). Secondly, the impact of
354 climate on fire safety is demonstrated through S_{VC} and S_{CSP} . Latin Hypercube Sampling
355 (LHS), with a number of 16384 set of parameters, will be used in accordance with Monte
356 Carlo methodology.

357

358 7. Case study and model description

359 A simple geometry is considered. The objective is to evaluate how fire safety
360 consideration interacts with passive building design strategies. Different building
361 parameters (characteristics) for fire safety and thermal comfort are evaluated. A first
362 “dissociated” fire safety study is conducted in order to evaluate the influence of WWR and
363 inlet position with CFAST. Parameters related to the first study are describes in Table 1.
364 Two sensitivity analyses are then carried out. The first consists in the evaluation of the
365 impact of several parameters including inlet position, and flow rate but excluding WWR,
366 on the fire safety measure defined in [14]. The exclusion is due to a CFAST model

367 characteristic which does not allow to simulate wind driven ventilation like in
 368 EnergyPlus. Hence, to mimic natural ventilation, the assumption is to model inlet and
 369 outlet mechanical vent (Figure 6). Inlet position and flow rate are here considered as
 370 input parameters. CFAST does not allow to give length and height of mechanical vents. As
 371 a consequence, the influence of WWR is evaluated through another sensitivity analysis
 372 with no mechanical vent but just natural vent exhaust (Windows).
 373 Table 2 presents input parameters information for the combined study. It has to be
 374 underlined that the two models, i.e. EnergyPlus (E+) and CFAST models, have the same
 375 initial parameters in terms of buildings and windows geometry, resulting in four common
 376 parameters (Figure 7).

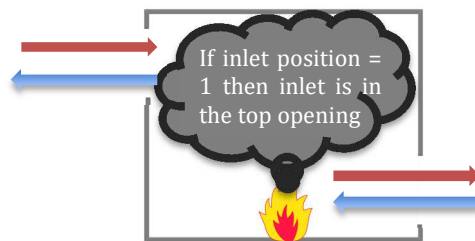

377
378
379 *Figure 6: Inlet and outlet position set up in CFAST*

380 *Table 1: Parameters and their range for smoke extraction study*

Parameters	Distribution	Range	Type
Room width	Uniform	[4m ; 6m]	Continuous
Room height	Uniform	[m ; m]	Continuous
Room length	Uniform	[2.5m ; 3.5m]	Continuous
Window to wall ratio	Uniform	[0.05m ;0.6m]	Continuous
Outdoor temperature	Uniform	[15°C ; 35°C]	Continuous
Indoor temperature	Uniform	[18 °C; 37 °C]	Continuous
Relative humidity	Uniform	[50% ; 80%]	Continuous
Inlet Position	Uniform	[1 ; 2]	Discrete
Flow Rate	Uniform	[0ACH; 40ACH]	[]

381

382 Specific parameters are defined for the Energy Plus and CFAST simulations. Concerning
383 the EnergyPlus specific parameters, the impact of the different components' thickness
384 and the room orientation are evaluated. This represents eight parameters (Figure 7). Only
385 three parameters are specific to the CFAST model: Relative Humidity, Indoor
386 Temperature and Outdoor Temperature (Figure 7).

387 *Table 2: Parameters and their range for combined fire and comfort study*

Parameters	Distribution	Range	Type
Room width	Uniform	[4m ; 6m]	Continuous
Room height	Uniform	[6m ; 12m]	Continuous
Room length	Uniform	[2.5m ; 3.5m]	Continuous
Window to wall ratio	Uniform	[0.05m ; 0.6m]	Continuous
Delta_h	Uniform	[0.5m ; 1.5m]	Continuous
Insulation thickness	Uniform	[0.02m ; 0.08m]	Continuous
Shading tilt angle	Uniform	[90° ; 140°]	Continuous
Shading length	Uniform	[0.1m ; 1.5m]	Continuous
Discharge coefficient	Uniform	[0.35 ; 0.67]	Continuous
Room orientation	Uniform	[0° ; 360°]	Continuous
Outdoor temperature	Uniform	[15°C ; 35°C]	Continuous
Indoor temperature	Uniform	[18 °C; 37 °C]	Continuous
Relative humidity	Uniform	[50% ; 80%]	Continuous
Occupation type	Uniform	[1 ; 2]	Discrete
Weather file	Uniform	[1 ; 4]	Discrete
Building type	Uniform	[1 ; 4]	Discrete

388

Common parameters

Window to wall ratio : 1 parameter

Room geometry : 3 parameters (Height, Width, Length)

Delta_h : (height difference between the two openings (2))

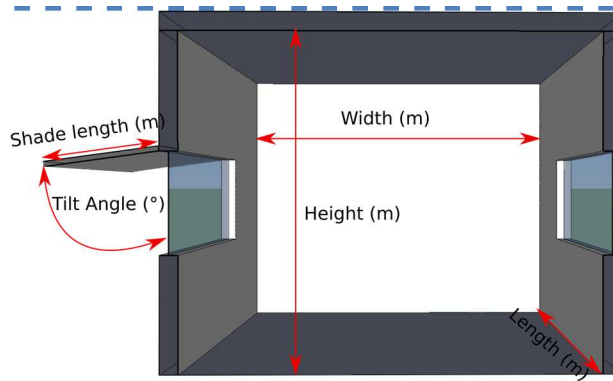

EnergyPlus parameters

Wall insulation thickness : 1 parameter

Roof insulation thickness : 1 parameter

Room geometry : 3 parameters

Room orientation : 1 parameter

Window geometry : 1 parameter (Window to wall ratio)

Discharge coefficient : 1 parameter

Tilt angle : 1 parameter

Length : 1 parameter

Discrete parameters:

Weather file : 1 parameter

Occupation profile : 1 parameters

Building type : 1 parameter

CFAST Parameters :

Indoor Conditions : 2 parameters (Temperature, Relative Humidity) ;

Outdoor Temperature : 1 parameter

Figure 7: Description of the assessed model

389

390 Heat Release Rate is set at 3 kW/m^2 and is placed in the middle of the room for each case.

391 Hence HRR lies between 30 kW and 70 kW which correspond to shelf wood bookcase

392 burning with files on. The fire size is 5% of the floor surface area. The fire reaches its

393 maximal value at the mid-simulation time. In addition, the main objective concerning fire

394 risk assessment is to evaluate the ability of the occupants to escape in case of fire. Hence,
 395 the first 15 minutes of a fire event are simulated. The room studied has typical single room
 396 ratio. The outdoor temperature range is also typical for Reunion Island, with a tropical
 397 climate. Considering a naturally ventilated building, indoor temperature and indoor
 398 relative humidity are within the range of local weather data. Climate conditions inputs are
 399 used within the CFAST software as well as for the critical velocity calculation (2). All the
 400 parameters and the related boundaries are given in Table 2. The variable h defined in (1)
 401 is relative to the difference between the middle of the top opening and the middle of the
 402 bottom opening. This value is only implemented in the Critical Velocity calculation and
 403 not in CFAST or EnergyPlus model for the second analysis. However, the top opening in
 404 EnergyPlus is assume to be always in the same façade. This allows to calculate CSP.
 405 Thermal comfort in tropical climate is evaluated. As a result, relative humidity and
 406 thermal comfort are model outputs used in order to evaluate comfort performance. The
 407 extended Givoni's climatic diagram proposed by Lenoir [43] allows to plot the data. The
 408 simulated room is considered as naturally ventilated. ΔC_p in (1) is calculated thanks to
 409 Swami's and Chandra correlation [57].

410

411 All parameters are assumed as uniformly distributed. Weather file, occupation type as
 412 well as building type are discrete parameters used in order to build scenarios.

413

414 **7.1. Evaluated building type**

415 The tested building type is based on the commonly building that can be find in Reunion
 416 island. Table 3 presents the chosen building composition in terms of wall and roof.

417 *Table 3: Tested building type*

Building Type	Concrete	Wood	metal	Concrete + wood
---------------	----------	------	-------	-----------------

Wall (ext/.../int)	Concrete/Insulation/ Plasterboard	Wood/airspace/Insul ation /plasterboard	Metal Sheet/airspace/Insulation /plasterboard	Wood/Concrete/Ins ulation/Plasterboard
Roof (ext/.../int)	(Metal sheet/Airspace/Insul ation/plasterboard)	(Metal sheet/Airspace/Insul ation/plasterboard)	(Metal sheet/Airspace/Insulation/plas terboard)	(Metal sheet/Airspace/Insul ation/plasterboard)

418

419 This parameter will be a discrete parameter and will allow to analyse building type impact
420 on comfort measures in naturally ventilated building.

421

422 7.2. Occupation profile

423 Concerning the occupation, only two option is tested: Office occupancy and home
424 occupancy. These information is taken from EnergyPlus default schedule. The objective
425 here is not to specially represents reality but to analyse qualitatively the impact of a day
426 and night occupancy on the way of optimize a naturally ventilated building

427

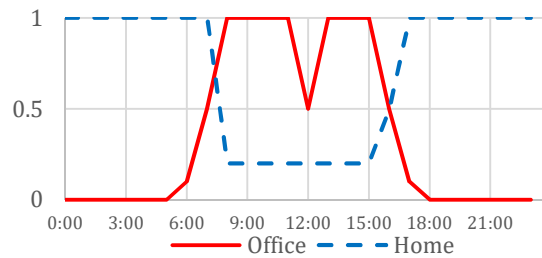

428

429

Figure 8: Assessed occupancy profile

430 This parameter will allow to discuss relative occupancy importance on the designer point
431 of view for free running building which indoor conditions strongly depends on outdoor
432 conditions.

433

434 8. Methodology

435 The first step of this study is to identify the most impacting parameters during a fire event
 436 excluding fire characteristics as an input for sensitivity analysis. Fire size will vary with
 437 the floor surface area. For this first study only CFAST will be use. The second approach is
 438 to use an index that combines fire safety and comfort, since they can interact while natural
 439 ventilation operates [14]. The disjunction connective function based combined index (8)
 440 is used here to analyse the combination of C_{NMV} and S_{VC} :

$$I = \alpha \times S_{VC} + \beta \times C_{NMV} \quad (8)$$

441 Weighing coefficients α and β that range between [0,1] are used to give relative
 442 importance on one or the other output measure.

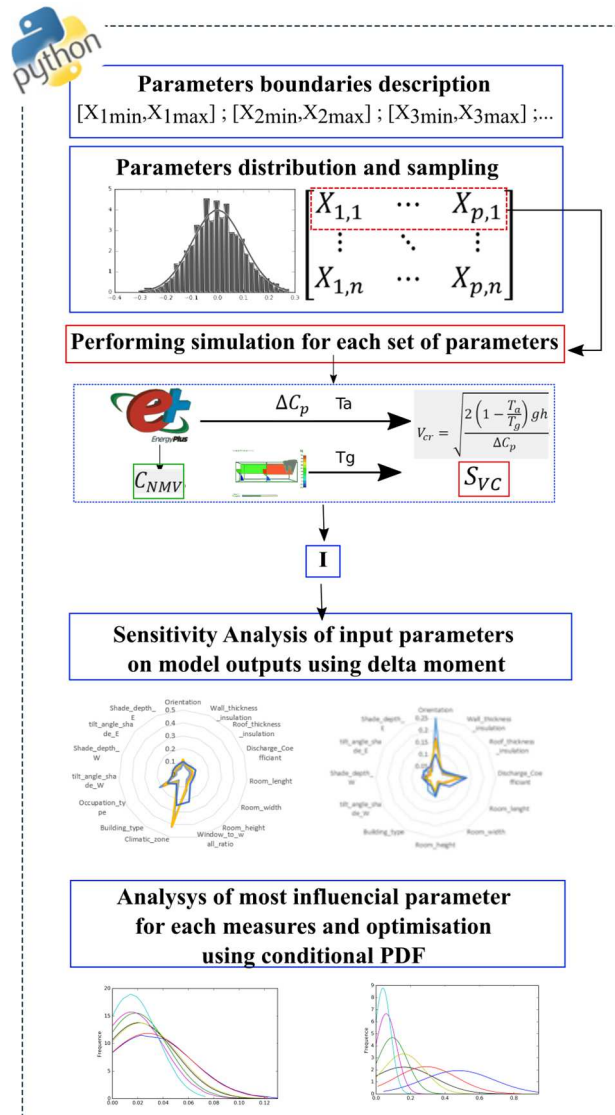

443
 444 *Figure 9: Python process for the proposed optimisation methodology*

445 As in Juhoor et al. study [14], in order to keep the new index normalized, we set: $\beta = (1 -$
446 $\alpha)$. To realize the analysis, Python software is used as an interfacing layer and its Salib
447 library is used to perform sensitivity analysis [58]. The objective is to give designers the
448 opportunity to understand how safety and comfort can interact and why it is important
449 to consider fire safety in the early design of passive building providing wind driven
450 natural ventilation.

451

452 9. Results

453 9.1. Most impacting parameter in fire model for naturally ventilated room using 454 CFAST

455 The following sensitivity analysis, using delta moment measures, shows how important
456 inlet and outlet position are in terms of interface layer height, upper layer and lower layer
457 temperature. With a simple multizone layer as CFAST the importance of window position
458 as well as flow rate, during a fire event is demonstrated in Figure 10.

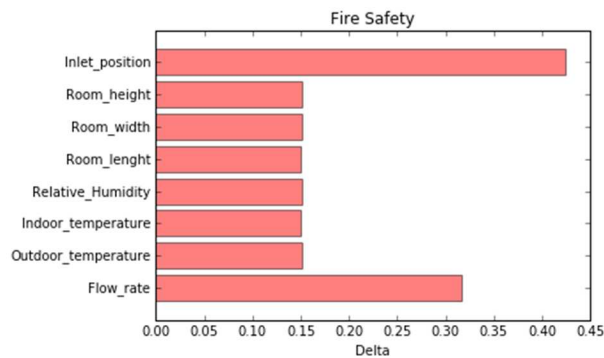

459

460 *Figure 10 : Delta moment values for Fire Safety Study measuring fire model inputs impact on safety measure set in [14]*

461

(Mechanical ventilation to mimic wind driven natural ventilation)

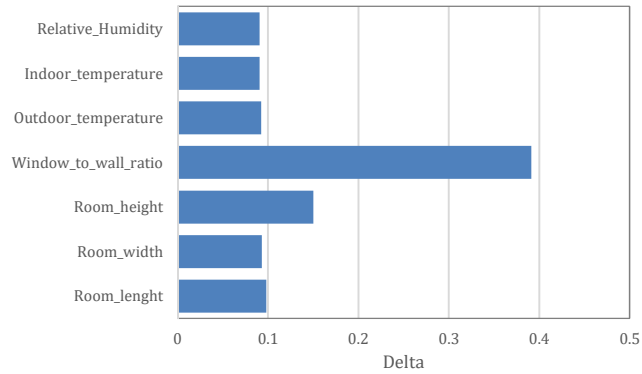

462

463

Figure 11: Delta moment values for Fire Safety Study measuring fire model inputs impact on S_{FED} . (Naturally ventilated without wind driven natural ventilation)

464

465

In this case wind driven ventilation was simulated with mechanical vent given that CFAST does not consider wind driven flow. It appears that inlet position as well as flow rate have a great impact on the safety measure set in [14].

468

469

A second case is simulated while the windows are opened, allowing natural ventilation. The result exposed in Figure 11 presents sensitivity measures for the same room but naturally ventilated without wind driven natural ventilation. Impact on S_{FED} is evaluated.

472

473

It appears in this case that Window to Wall Ration is by far the most impacting parameters. As a consequence, WWR, Inlet position, as well as flow rate can be considered as the most impacting in naturally ventilated cases. Knowing that those parameters also play a pivotal role contaminant dissipation in cross and naturally ventilated room [29], one cannot designed passive building without considering smoke extraction performance. It is now important to study the introduced safety index S_{VC} and S_{CSP} to demonstrate the climatic dependence of fire safety in cross and naturally ventilated room using zonal and nodal models as well as the presented combined index (8).

481

482 **9.2. Comfort and safety interaction through combined Index**

483 In this part the combined index is used to demonstrate the weather importance when
484 studying fire safety in naturally ventilated room by fixing the weighing coefficient α to
485 different values. Figure 12 and Figure 13 shows the delta moment measure associated
486 with the impact of each inputs on global index for summer period and winter period, and
487 for $\alpha = 0.1, 0.5$ or 0.9 .

488

489 It can first be observed, difference between parameter impact if we set the study in
490 summer or winter, whatever the value of α . The first conclusion is then that both safety
491 through critical velocity measure S_{VC} and comfort through C_{NMV} are strongly dependent
492 of the location i.e dependent of the weather. Focusing on Figure 12, one can relate that for
493 $\alpha = 0.9$ (importance given on safety), the most impacting parameter is by far is the
494 weather file.

495

496 Hence the strong dependence between safety and climate is highlighted in summer
497 period. When $\alpha = 0.1$, both weather file and occupation are important. Knowing that
498 natural ventilation systems are usually designed for summer period, designers could not
499 think about safety without adapting opening position as well as WWR to the specificity of
500 the climate.

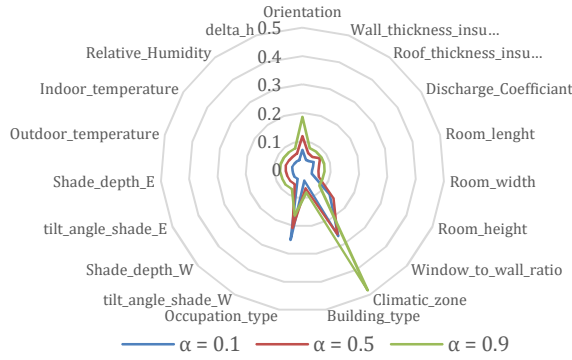

501

502

Figure 12: Delta moment for different values of α and for Summer Period

503

Figure 13 is also very interesting due to its difference with summer period. Indeed we can

504

observe that in winter, the orientation is as impacting as the climatic zone when fixing

505

$\alpha = 0.9$. When $\alpha = 0.1$, occupation and weather file are the most impacting parameters.

506

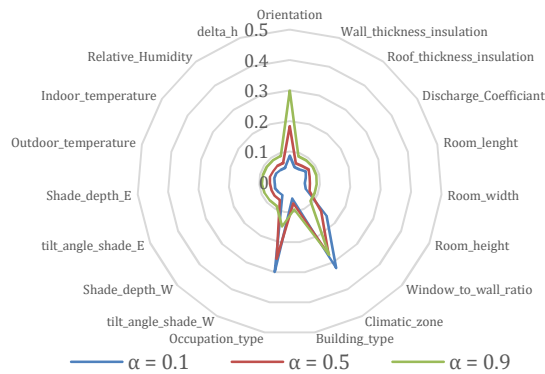

507

508

Figure 13: Delta moment for different values of α and for Winter Period

509

For both summer and winter case, $\alpha = 0.5$ allows to both take into account safety and

510

comfort. Then for a combined sensitivity analysis, it can be recommended to analyze the

511

results when $\alpha = 0.5$. This allows to give to the designer a global view of what is really

512

important to consider when realizing of retrofitting a building. The study of $\alpha = 0.9$ or 0.1

513

can then be used to find contentious parameters by plotting the conditional distribution

514

of most impacting parameters.

515

Next part focuses on the study of conditional distribution of the output fixing the most

516

impacting parameter for both cases when $\alpha = 0.9$ or 0.1 .

517

518 **9.3. Conditioned output distribution**

519 This part deals with refined analysis of output distribution and conditional output
520 distribution regarding the most impacting parameters when $\alpha = 0.9$ or 0.1 . In this part,
521 kernel density estimation (KDE) is used in order to plot the output distribution in each
522 case. Firstly, the weather file is fixed in order to observe whether the same climate is
523 favourable to both safety and comfort. Secondly, two climate locations are deeply studied.
524 For a specific location, as well as for a specific occupation type, global output distributions
525 fixing Window to Wall Ratio to specific range are plotted. Thirdly, the same method is
526 applied to the room's orientation

527

528 ***Output distribution fixing Weather Files***

529 Figure 14 and Figure 15 present kde of the output knowing the location for $\alpha = 0.1$ or 0.9 .
530 It can be highlight that a huge difference exists between the different locations whether
531 $\alpha = 0.1$ or 0.9 . Moreover, comparing the two graphs, it can be observe that the same
532 location could be very positive when weigh is put on comfort but negative when
533 importance is given to safety. Let's take for example the case of Gillot. Typically, Gillot has
534 a high wind potential (cf. part1) and can thus be favorable when natural ventilation is
535 allowed in building, considering building element allowing to regulate wind speed. Hence
536 for Gillot, the output varies between 0.6 and 1 with two pikes from 0.7 and 0.8 as well as
537 from 0.8 and 1.

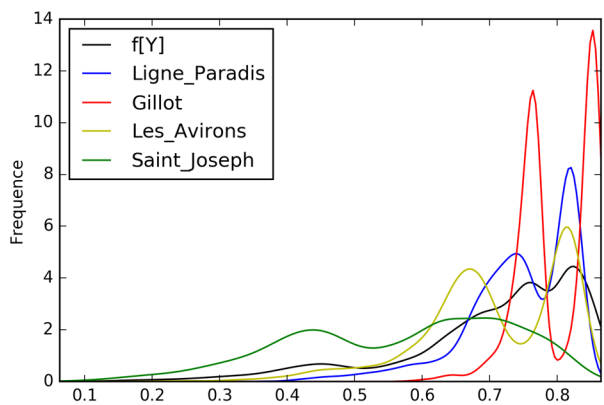

538
539

Figure 14: Kernel density estimation of the output knowing the location for $\alpha = 0.1$.

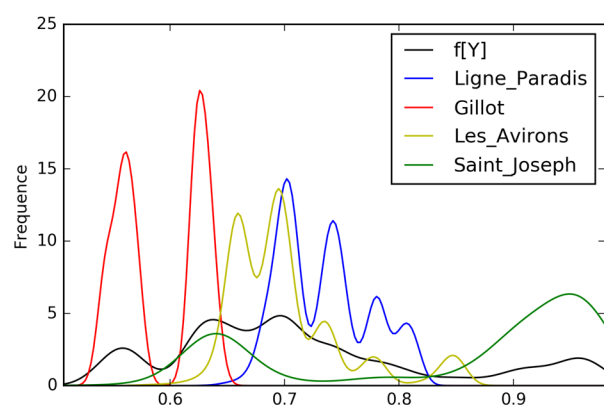

540
541

Figure 15: Kernel density estimation of the output knowing the location for $\alpha = 0.9$.

542 The two spikes, or kernel, observed are related to the occupation type. Observing now the
 543 same location but fixing $\alpha = 0.9$, Gillot is the climate with the most negative impact, with
 544 a combined index ranging approximately from 0.55 to 0.65. The same trend regarding α
 545 value can be observed for each climate location but except for Saint-Joseph. The reason of
 546 the observed difference is that Saint-Joseph weather file has an irregularity regarding
 547 wind speed and direction.

548 This study allows to conclude on the weather dependence of fire safety in naturally
 549 ventilated room, for the case study, as thermal comfort is link to climate. In the one case,
 550 a given weather file can be suitable to reach appropriate thermal comfort level, but in the
 551 other case, can be responsible to a poor fire safety level amplitude. Then, indepth study
 552 should be realize for each location, each microclimate, in order to not only consider

553 thermal comfort but also in order to take into account fire safety as a key consideration
554 to bioclimatic and sustainable construction. For next discussion, Gillot with office
555 occupancy will be used to understand how most impacting parameters can interact taking
556 different values of α .

557

558 ***Output distribution fixing WWR***

559

560 Figure 16 and Figure 17 present KDE for the output knowing the location and occupancy
561 for different range of WWR for $\alpha = 0.1$ or 0.9 . When $\alpha = 0.1$, and knowing that the study
562 focus on summer, it appears that high range of WWR (between 50% and 60%) is more
563 positive regarding thermal comfort compared to low range of WWR (between 0% and
564 10%). Indeed, when fixing WWR from 50% to 60%, global index varies from 0.72 to 1
565 whereas it varies from 0 to 1 with a more dispersed density when ranging from 0% to
566 10%.

567

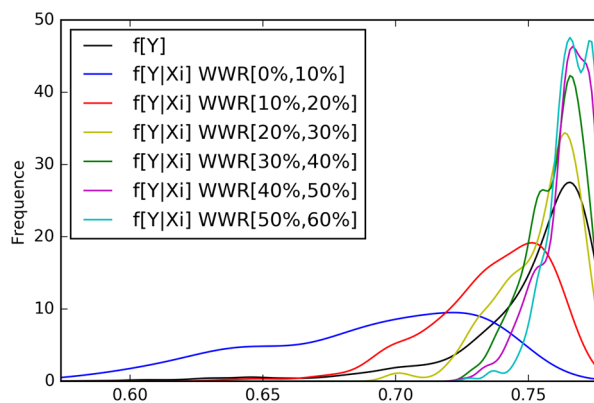

568

569 *Figure 16: Kernel density estimation of the output knowing the location (Gillot) and occupancy (Office) for different range of*
570 *WWR and for $\alpha = 0.1$.*

571 However the trend is completely different when the accent is put on safety. Indeed when
572 $\alpha=0.9$ (Figure 17), two groups of kernel can be identified concerning the conditional

573 output. The results is not as significant as when for $\alpha=0.1$. Hence there is not high
 574 discrepancies when $\alpha=0.9$ comparing to the case when $\alpha=0.1$. In order to understand the
 575 presence of the two kernel groups, conditional kde is plotted for different range of
 576 orientation.

577

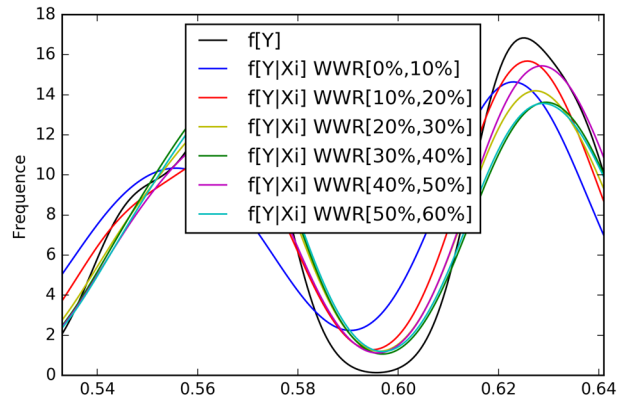

578

579 *Figure 17: Kernel density estimation of the output knowing the location (Gillot) and occupancy (Office) for different range of*
 580 *WWR and for $\alpha = 0.9$.*

581 ***Output distribution fixing the orientation***

582

583 Figure 18 and Figure 19 show kde for the output knowing the location and occupancy for
 584 different range of room orientation for $\alpha = 0.1$ or 0.9 . Firstly, Figure 19 allows to
 585 understand the presence of two kernel groups observed in Figure 17.

586

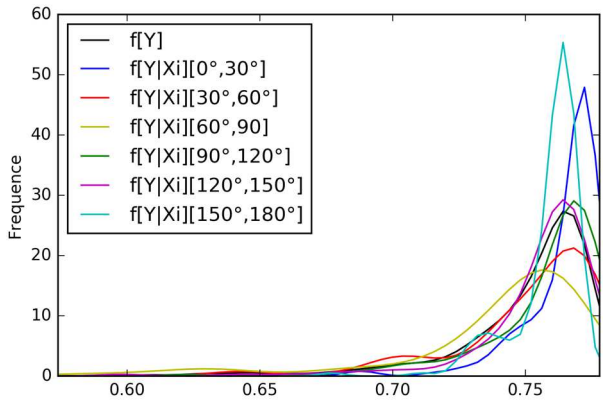

587

588
589

Figure 18: Kernel density estimation of the output knowing the location (Gillot) and occupancy (Office) for different range of room orientation and for $\alpha = 0.1$.

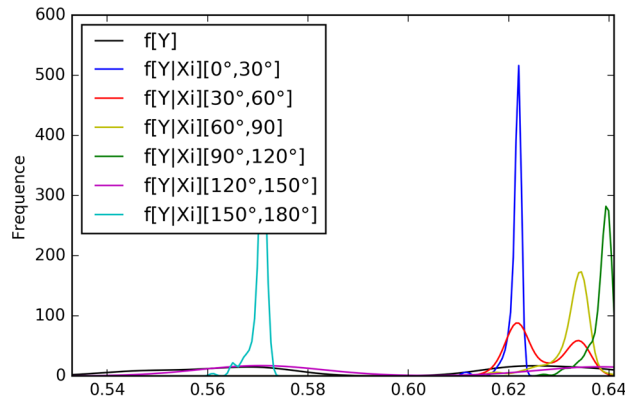

590
591
592

Figure 19: Kernel density estimation of the output knowing the location (Gillot) and occupancy (Office) for different range of room orientation and for $\alpha = 0.9$.

593 Indeed, it can be observed in Figure 19 that for a range of orientation between 150° and
594 180° , global index is very low compared to the other range. Two groups are also observed
595 in this case. This discrepancies causes the observed groups of densities in Figure 17.
596 Secondly, it can be concluded that orientation is typically a conflicting parameter when
597 fixing it to some range and more particularly when it is fixed between 150° and 180° .
598 Indeed, this range of orientation induces high values of global index when $\alpha=0.1$, but also
599 really poor index when $\alpha=0.9$. Designers should be careful about the orientation of a room
600 or openings position when thinking about construction that allows natural ventilation if
601 fire safety is also taken into account.

602
603

10. Conclusion

604 This study has numerically demonstrated the relation between fire safety and thermal
605 comfort in naturally ventilated room using nodal and zonal models and sensitivity
606 analysis by mean of Delta moment introduced by Borgonovo. The advantage of using this
607 methods here is to have an absolute impact of sensitivity measure. A simple case study

608 was taken in order to check fire safety level taking into account a wide range of
609 uncertainties. A combined index methodology was applied to find the relation between
610 thermal comfort and fire safety.

611
612 A first dissociated study was conducted in order to show how fire safety level, in terms of
613 Fractional Effective Dose of toxic gas, is sensitive to the inlet position as well as to the
614 Window to Wall Ratio (WWR). Using a disjunction function based global index, a global
615 study was realized combining a critical velocity measure as a safety index, and a climatic
616 diagram based comfort index as a thermal comfort measure. It appears that global index
617 is sensitive to the location, the WWR, as well as the occupation when both fixing weighing
618 coefficient α to 0.1 or 0.9. Hence the climate dependence of fire safety level was
619 demonstrated.

620
621 The use of kde allows in the last part of the study to highlight the room orientation as a
622 conflicting parameter when fixing its values to a specific range. It is hence important to
623 apply this kind of methodology when allowing natural ventilation inside a building in
624 order to avoid poor safety level that can lead to casualties in case of fire event.

625
626 By way of conclusion, this study is the first of its kind that tries to evaluate the link
627 between thermal comfort and fire safety level in passive buildings. The study highlights
628 the strong dependence between fire safety level, using Critical Safety Period and Critical
629 Velocity, and environmental and building variables as location (wind speed and
630 direction), inlet position, orientation and WWR. However the use of Critical Velocity is
631 here a first step and can be questionable since it is based on a macroscopic model that

632 considers a full mixed ambiance inside the room. Further study should be conducted
633 either numerically by mean of KDE or experimentally.

634

635 **11.Acknowledgment**

636 This work was financially supported by Intégrale Ingénierie consultancy and developed
637 in the fire and comfort research department. This work cannot be achieved without the
638 experiment led in IUTSI Laboratory along with Olivier Vauquelin’s team and Kevin Varrall.

639

640 **12. References**

- 641 [1] SPL Energies Réunion, “Bilan énergétique de La Réunion.” 2015.
- 642 [2] Ministère du logement, “Norme française, Sécurité Incendie, Arrêté du 31 janvier
643 1986.” Ministère du logement, 1986.
- 644 [3] “Norme française, Sécurité Incendie, Ministère de l’intérieur, Arrêté du 18 octobre
645 1977.” Ministère de l’intérieur, 1977.
- 646 [4] “Norme française, Sécurité Incendie, Ministère du travail, Arrêté du 5 août 1992.”
647 Ministère du travail, 1992.
- 648 [5] J.-M. D’Hoop, “Sécurité incendie bâtiment,” Tech. Ing., 2002.
- 649 [6] W. Gao, N. Liu, M. Delichatsios, X. Yuan, Y. Bai, H. Chen, Zhang, “Fire spill plume from
650 a compartment with dual symmetric openings under cross wind,” Combust. Flame,
651 Mar. 2016.
- 652 [7] L. Yi, Y. Gao, J. L. Niu, and S. J. Yang, “Study on effect of wind on natural smoke exhaust
653 of enclosure fire with a two-layer zone model,” J. Wind Eng. Ind. Aerodyn., vol. 119,
654 pp. 28–38, 2013.
- 655 [8] C. Lai, C.-J. Chen, M.-J. Tsai, M.-H. Tsai, and T.-H. Lin, “Determinations of the fire smoke
656 layer height in a naturally ventilated room,” Fire Saf. J., vol. 58, pp. 1–14, mai 2013.

- 657 [9] A. M. Salem, "Use of Monte Carlo Simulation to assess uncertainties in fire
658 consequence calculation," *Ocean Eng.*, vol. 117, pp. 411–430, 2016.
- 659 [10] ISO/TR 16738:2009 Fire-safety engineering – Technical information on methods for
660 evaluating behaviour and movement of people. 2009.
- 661 [11] D. Kong, S. Lu, Q. Kang, S. Lo, and Q. Xie, "Fuzzy Risk Assessment for Life Safety Under
662 Building Fires," *Fire Technol.*, vol. 50, no. 4, pp. 977–991, 2014.
- 663 [12] A. Allard, N. Fischer, F. Didieux, E. Guillaume, and B. Iooss, "Evaluation of the most
664 influent input variables on quantities of interest in a fire simulation," *J. Société Fr.
665 Stat.*, vol. 152, no. 1, pp. 103–117, 2011.
- 666 [13] R. D. Peacock, P. A. Reneke, and G. P. Forney, CFAST-consolidated model of fire
667 growth and smoke transport (version 6) user's guide. Citeseer, 2013.
- 668 [14] K. Juhoor, L. Lemaitre, M. Boulinguez, and A. Bastide, "Combined Fire Safety and
669 Comfort Study Using Moment Independent and Variance Based Method," in *BS 2017
670 proceedings*, San Francisco, 2017.
- 671 [15] R. F. Rupp, N. G. Vásquez, and R. Lamberts, "A review of human thermal comfort in
672 the built environment," *Energy Build.*, vol. 105, pp. 178–205, Oct. 2015.
- 673 [16] G. S. Brager and R. J. de Dear, "Thermal adaptation in the built environment: a
674 literature review," *Energy Build.*, vol. 27, no. 1, pp. 83–96, 1998.
- 675 [17] P. O. Fanger, "Thermal comfort. Analysis and applications in environmental
676 engineering," p. 244 pp., 1970.
- 677 [18] B. Givoni, "Man, climate and architecture," Elsevier; 1969.
- 678 [19] R. de Dear and J. Kim, "Thermal Comfort Inside and Outside Buildings," in *Advanced
679 Environmental Wind Engineering*, Y. Tamura and R. Yoshie, Eds. Springer Japan, pp.
680 89–99., 2016

- 681 [20] R. de Dear and G. S. Brager, "Developing an adaptive model of thermal comfort and
682 preference," *Cent. Built Environ.*, 1998.
- 683 [21] M. A. Humphreys, H. B. Rijal, and J. F. Nicol, "Updating the adaptive relation between
684 climate and comfort indoors; new insights and an extended database," *Build.
685 Environ.*, vol. 63, pp. 40–55, 2013.
- 686 [22] H. Breesch and A. Janssens, "Building simulation to predict the performances of
687 natural night ventilation: uncertainty and sensitivity analysis," in *Pro. 9th Int. IBPSA
688 Conf*, 2005.
- 689 [23] S. de Wit and G. Augenbroe, "Analysis of uncertainty in building design evaluations
690 and its implications," *Energy Build.*, vol. 34, no. 9, pp. 951–958, 2002.
- 691 [24] H. Hu and G. Augenbroe, "A stochastic model based energy management system for
692 off-grid solar houses," *Build. Environ.*, vol. 50, pp. 90–103, 2012.
- 693 [25] W. Tian, "A review of sensitivity analysis methods in building energy analysis,"
694 *Renew. Sustain. Energy Rev.*, vol. 20, pp. 411–419, 2013.
- 695 [26] E. Borgonovo, "A new uncertainty importance measure," *Reliab. Eng. Syst. Saf.*, vol.
696 92, no. 6, pp. 771–784, 2007.
- 697 [27] H. Chen, N. Liu, and W. Chow, "Wind effects on smoke motion and temperature of
698 ventilation-controlled fire in a two-vent compartment," *Build. Environ.*, vol. 44, no.
699 12, pp. 2521–2526, 2009.
- 700 [28] E. Borgonovo, "Measuring uncertainty importance: investigation and comparison of
701 alternative approaches," *Risk Anal.*, vol. 26, no. 5, pp. 1349–1361, 2006.
- 702 [29] Y. Tominaga and B. Blocken, "Wind tunnel analysis of flow and dispersion in cross-
703 ventilated isolated buildings: Impact of opening positions," *J. Wind Eng. Ind.
704 Aerodyn.*, vol. 155, pp. 74–88, 2016.

- 705 [30] T. van Hooff, B. Blocken, and Y. Tominaga, "On the accuracy of CFD simulations of
706 cross-ventilation flows for a generic isolated building: Comparison of RANS, LES and
707 experiments," *Build. Environ.*, vol. 114, pp. 148–165, 2017.
- 708 [31] N. F. P. Association, N. F. P. Association, and others, *NFPA 921, guide for fire and
709 explosion investigations*. National Fire Protection Association, 2008.
- 710 [32] E.E. Zukoski, T. Kubota, K. Cetegen, "Entrainment in fire plumes," *Fire Saf. J.*, vol. 3,
711 pp. 107–121, 1981.
- 712 [33] J. Prahl and H. W. Emmons, "Fire induced flow through an opening," *Combust. Flame*,
713 vol. 25, pp. 369–385, 1975.
- 714 [34] L. Y. Cooper, M. Harkleroad, J. Quintiere, and W. Rinkinen, "An Experimental Study of
715 Upper Hot Layer Stratification in Full-Scale Multiroom Fire Scenarios," *J. Heat
716 Transf.*, vol. 104, no. 4, pp. 741–749, 1982.
- 717 [35] G. Heskestad, "Fire Plumes, Flame Height, and Air Entrainment," in *SFPE Handbook
718 of Fire Protection Engineering*, M. J. Hurley, D. T. Gottuk, J. R. H. Jr, K. Harada, E. D.
719 Kuligowski, M. Puchovsky, J. L. Torero, J. M. W. Jr, and C. J. WIECZOREK, Eds. Springer
720 New York, pp. 396–428, 1995.
- 721 [36] John H. Klote and H. E. Nelsen, "Smoke movement in buildings," in *Fire Protection
722 Handbook*, Section 7, Chapter 6, 18th ed., National Fire Protection Association, One
723 Batterymarch Park, Quincy, MA, 1997.
- 724 [37] H. Pretrel, A. Koched, and L. Audouin, "Doorway Flows Induced by the Combined
725 Effects of Natural and Forced Ventilation in Case of Multi-compartments Large-Scale
726 Fire Experiments," *Fire Technol.*, pp. 1–26, 2015.
- 727 [38] A. Koched, H. Pretrel, O. Vauquelin, and L. Audouin, "Experimental determination of
728 the discharge flow coefficient at a doorway for fire induced flow in natural and mixed
729 convection," *Fire Mater.*, p. n/a-n/a, 2014.

- 730 [39] M. Kobes, I. Helsloot, B. de Vries, and J. G. Post, "Building safety and human behaviour
731 in fire: A literature review," *Fire Saf. J.*, vol. 45, no. 1, pp. 1–11, 2010.
- 732 [40] M. J. Madden and others, "SFPE engineering guide to application of risk assessment
733 in fire protection design," *Soc. Fire Prot. Eng.*, 2005.
- 734 [41] D. W. Etheridge and M. Sandberg, "A simple parametric study of ventilation," *Build.
735 Environ.*, vol. 19, no. 3, pp. 163–173, 1984.
- 736 [42] O. Vauquelin, G. Michaux, and C. Lucchesi, "Scaling laws for a buoyant release used to
737 simulate fire-induced smoke in laboratory experiments," *Fire Saf. J.*, vol. 44, no. 4, pp.
738 665–667, 2009.
- 739 [43] A. Lenoir, "On Comfort in Tropical Climates. The Design and Operation of Net Zero
740 Energy Buildings.," phdthesis, Université de La Réunion, 2013.
- 741 [44] C. LUCCHESI, "Etude du mouvement d'un fluide à faible masse volumique entre deux
742 compartiments reliés par une ouverture de type porte: Application à la propagation
743 de la fumée d'incendie," thesis, Université de la méditerranée - Aix-Marseille II, 2009.
- 744 [45] Y. J. P. Lin and P. F. Linden, "Buoyancy-driven ventilation between two chambers," *J.
745 Fluid Mech.*, vol. 463, pp. 293–312, 2002.
- 746 [46] Y. Li, V. C. W. Shing, and Z. Chen, "Fine bubble modelling of smoke flows," *Fire Saf. J.*,
747 vol. 38, no. 3, pp. 285–298, 2003.
- 748 [47] N. A. Dembsey, P. J. Pagni, and R. B. Williamson, "Compartment fire experiments:
749 Comparison with models," *Fire Saf. J.*, vol. 25, no. 3, pp. 187–227, 1995.
- 750 [48] K. D. Steckler, H. R. Baum, and J. G. Quintiere, "Fire induced flows through room
751 openings-flow coefficients," *Symp. Int. Combust.*, vol. 20, no. 1, pp. 1591–1600, 1985.
- 752 [49] S. Kerber and J. A. Milke, "Using FDS to Simulate Smoke Layer Interface Height in a
753 Simple Atrium," *Fire Technol.*, vol. 43, no. 1, pp. 45–75, 2007.

- 754 [50] J. Gong and Y. Li, "CFD modelling of the effect of fire source geometry and location on
755 smoke flow multiplicity," *Build. Simul.*, vol. 3, no. 3, pp. 205–214, Jun. 2010.
- 756 [51] J. Hua, J. Wang, and K. Kumar, "Development of a hybrid field and zone model for fire
757 smoke propagation simulation in buildings," *Fire Saf. J.*, vol. 40, no. 2, pp. 99–119,
758 2005.
- 759 [52] S. LI, C. Su, and K.-C. Tsai, "A Study on Wind-Induced Smoke Extraction Systems for
760 Building Fires," in *MATEC Web of Conferences*, vol. 51, p. 02001, 2016.
- 761 [53] R. N. Meroney, D. W. Hill, R. Derickson, J. Stroup, K. Weber, and P. Garrett, "CFD
762 Simulation of ventilation and smoke movement in a large military firing range," *J.*
763 *Wind Eng. Ind. Aerodyn.*, vol. 136, pp. 12–22, 2015.
- 764 [54] International Organization for Standardization, *ISO/TR 16738 Fire-safety*
765 *engineering – Technical information on methods for evaluating behaviour and*
766 *movement of people.* 2009.
- 767 [55] F. Garde, M. David, L. Adelard, E. Ottenwelter. *Elaboration of thermal standards for*
768 *french tropical islands. Presentation of the PERENE Project. Proceedings of*
769 *Clima2005, Lausanne, 2005.*
- 770 [56] A. Saltelli, K. Chan, E. M. Scott, and others, *Sensitivity analysis*, vol. 1. Wiley New York,
771 2000.
- 772 [57] M.V. Swami and S. Chandra, "Correlations for pressure distribution on buildings and
773 calculation of natural-ventilation airflow," in *ASHRAE Transactions*, pp. 243–266,
774 1988.
- 775 [58] J. Herman and W. Usher, "SALib: An open-source Python library for sensitivity
776 analysis.," *J. Open Source Softw.*, 2017.

777