



HAL
open science

Percolation without FKG

Vincent Beffara, Damien Gayet

► **To cite this version:**

| Vincent Beffara, Damien Gayet. Percolation without FKG. 2017. hal-01626674v1

HAL Id: hal-01626674

<https://hal.science/hal-01626674v1>

Preprint submitted on 21 Nov 2017 (v1), last revised 14 Mar 2018 (v2)

HAL is a multi-disciplinary open access archive for the deposit and dissemination of scientific research documents, whether they are published or not. The documents may come from teaching and research institutions in France or abroad, or from public or private research centers.

L'archive ouverte pluridisciplinaire **HAL**, est destinée au dépôt et à la diffusion de documents scientifiques de niveau recherche, publiés ou non, émanant des établissements d'enseignement et de recherche français ou étrangers, des laboratoires publics ou privés.

PERCOLATION WITHOUT FKG

VINCENT BEFFARA AND DAMIEN GAYET

ABSTRACT. We prove a Russo-Seymour-Welsh theorem for large and natural perturbative families of discrete percolation models that do not necessarily satisfy the Fortuin-Kasteleyn-Ginibre condition of positive association. In particular, we prove the box-crossing property for the antiferromagnetic Ising model with small parameter, and for certain discrete Gaussian fields with oscillating correlation function.

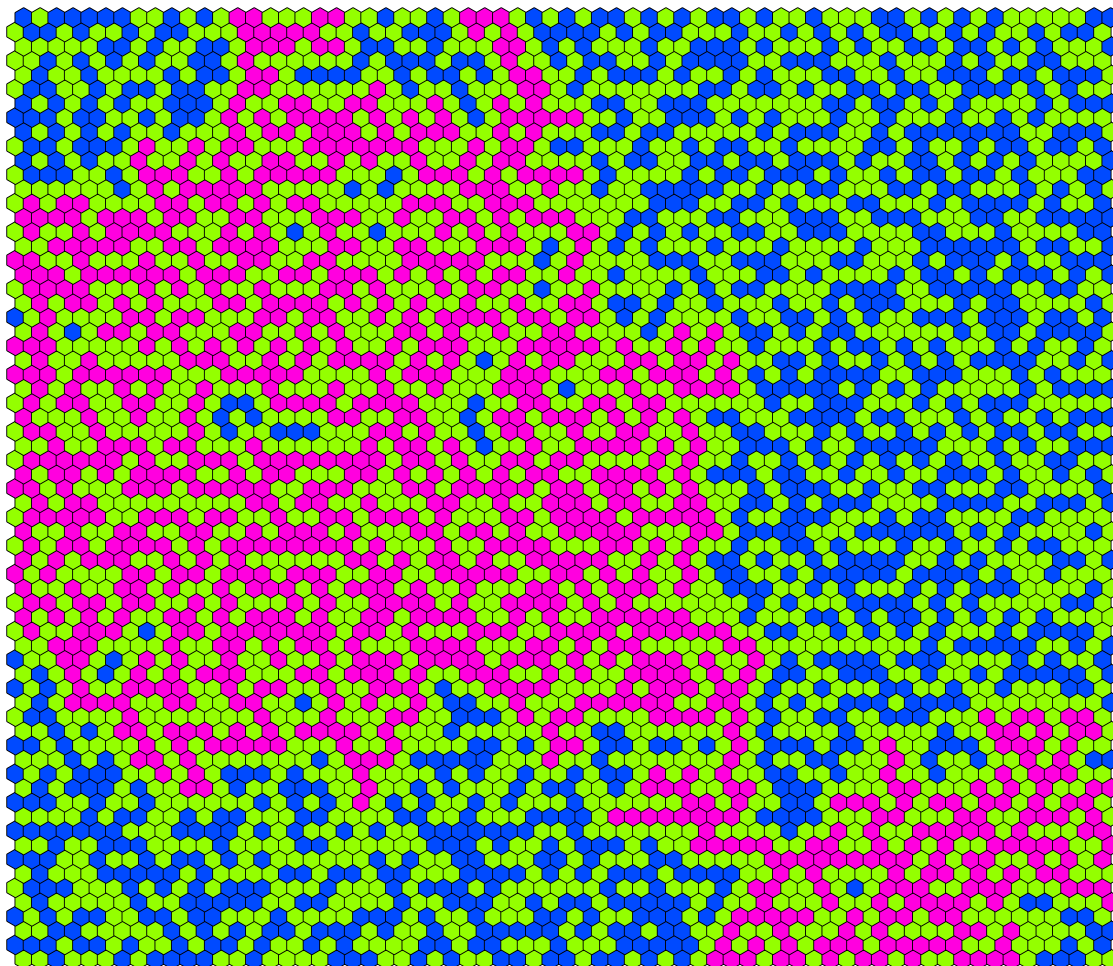

*The antiferromagnetic Ising model,
with a (percolating) component highlighted*

Keywords: Percolation, Ising model, negative association.

Mathematics subject classification 2010: 60K35, 60G15, 82B20

Date: November 21, 2017.

CONTENTS

1. Introduction	2
1.1. The setting	3
1.2. Topological definitions	4
1.3. Gaussian fields	6
1.4. The Ising model.	7
1.5. Open questions.	7
2. Proof of the main result	8
2.1. Well behaved processes	8
2.2. Ideas of the proof of Theorem 2.7	10
2.3. Topological preliminaries	10
2.4. Finite-range models	13
2.5. General models	24
3. Applications	27
3.1. Discrete Gaussian fields	27
3.2. The Ising model	29
Appendix A. A smoothed random wave model.	31
References	32

1. INTRODUCTION

The Fortuin-Kasteleyn-Ginibre condition (FKG for short) is a crucial tool in the study of percolation and the ferromagnetic Ising model. It states that two increasing events are positively correlated, which allows for instance to construct the pure phases of the Ising model or to build percolation crossings of long rectangles from more elementary blocks, typically crossings of squares; it is an essential tool in much of the literature in statistical mechanics. For Bernoulli percolation, it was first observed by Harris [10]; in the case of the sign of a Gaussian field, it was proved by Pitt [13] that if the correlation function is positive, then the FKG condition is satisfied.

The property was essential in our previous paper [1], where we proved that positively correlated Gaussian fields with sufficiently fast correlation decay satisfy the Russo-Seymour-Welsh property, which states that large rectangles of fixed aspect ratios are crossed by open clusters with uniformly positive probability (see Theorem 1.15 below for a precise statement). In [3], the authors noticed that, given a sequence of non-positively correlated Gaussian fields that converges to a positively correlated limit, it is possible to obtain similar lower bounds along sequences of rectangles provided that their size grows slowly enough; this allowed them to extend our results to the spherical geometry.

In the present paper, we prove RSW-type bounds for certain discrete, rapidly decorrelated planar models which do not exhibit the FKG property. To the best of our knowledge, this is the first proof of such a result in the usual setup of statistical mechanics, *i.e.* for fixed models in infinite volume.

The core idea of the argument is to obtain a finite-scale criterion, propagating estimates from one scale to the next thanks to a precise control of correlations rather than using positive association. The criterion is then an open condition on the model, implying that under the appropriate technical assumptions, perturbations of a reference model exhibiting the box-crossing property satisfy it as well.

As a first application, we prove that random signs given by discrete Gaussian fields that are perturbations of critical Bernoulli percolation satisfy RSW. This gives examples of fields with oscillating correlation function, see Corollary 1.17 and the appendix, for

which our previous result does not apply. As a second application, we prove that the antiferromagnetic Ising model with high negative temperature on the triangular lattice satisfies RSW, see Theorem 1.18.

1.1. The setting. This paper will be concerned with discrete models, defined on a periodic two-dimensional triangulation \mathcal{T} of the plane with enough symmetry. The set of vertices of \mathcal{T} will be denoted by \mathcal{V} , and the adjacency of two vertices v and v' will be denoted by $v \sim v'$; for any subset U of \mathcal{V} and any $r > 0$, U_r will denote the set of vertices that are within distance r (in \mathcal{T}) of the set U . We gather here the assumptions that we will be using for \mathcal{T} and the random functions:

Definition 1.1. A triangulation \mathcal{T} of \mathbb{R}^2 is said to be symmetric if its set \mathcal{V} of vertices is included in \mathbb{Z}^2 and if it is periodic and invariant under the rotation of angle $\pi/2$ around 0 and under horizontal reflection. A random function $f : \mathcal{V} \rightarrow \mathbb{R}$ is said to be symmetric (or self-dual) if it is invariant in distribution under the symmetries of \mathcal{T} and under sign change ($f \mapsto -f$). A random coloring, or model, is a random function taking values in $\{\pm 1\}$.

As a specific instance of a lattice satisfying the symmetry conditions, one can choose the face-centered square lattice (or “Union-Jack lattice”), though the specific choice will not be relevant in our proofs. The set of random fields on \mathcal{T} will be equipped with the topology of convergence of local observables:

Definition 1.2. A sequence (f_n) of random functions is said to converge locally to f if, for every $\varphi : \mathbb{R}^{\mathcal{V}} \rightarrow \mathbb{R}$ that depends only on finitely many coordinates, and is bounded and continuous, $E[\varphi(f_n)] \rightarrow E[\varphi(f)]$.

For any lattice \mathcal{T} and any random function f defined on \mathcal{V} , we denote by Ω^+ (resp. Ω^-) the subset of vertices in \mathcal{V} where f is positive (resp. negative). In this article, we will consider the *site percolation* associated to (f, \mathcal{T}) , namely an edge of \mathcal{T} is said to be *positive* or *open* if the signs at its extremities are positive.

Remark 1.3. In fact, our methods apply in more generality than stated above. In the setting of site models, our arguments can be transported to the regular triangular lattice as well, with only minor changes such as replacing squares with lozenges, rectangles with parallelograms, and so on; they will also apply to self-dual bond models satisfying the appropriate hypotheses. We chose to remain here within the setup of site models with square lattice symmetries to keep the core of the argument more apparent.

We will apply our methods and results in two classical cases:

- (1) the function f is a Gaussian field over \mathcal{V} ;
- (2) the function f denotes the spin in the Ising model on \mathcal{V} .

We will work in the more general setup of random colorings satisfying strong enough decorrelation assumptions, and then prove that these assumptions hold for both Gaussian fields with fast decay of correlations and Ising models with high enough temperature:

Definition 1.4. Let (f, \mathcal{T}) be a symmetric model.

- For any $\ell > 0$, f is said to have finite range at most ℓ , or to be ℓ -dependent, if whenever A and B are (deterministic) vertex sets separated by a graph distance at least equal to ℓ , the restrictions $f|_A$ and $f|_B$ are independent.
- For any $\ell < n$, denote by $\theta_f(n, \ell)$ the smallest total variation distance between the restrictions to $\Lambda_n := [-n, n]^2$ of f and a symmetric ℓ -dependent model. Note that $\theta_f(n, \ell)$ is non-decreasing in n , and non-increasing in ℓ .
- The model is said to be well decorrelated if there exist constants $C > 0$ and $\beta > 2\alpha > 0$ such that $\theta_f(n, \ell) \leq Cn^{\alpha}\ell^{-\beta}$ for all $0 < \ell < n$. A family $(f_u)_{u \in \mathcal{U}}$ is said

to be uniformly well decorrelated if for every u , f_u is well decorrelated, in such a way that the constants C , α and β can be chosen uniformly in u .

By definition, any random function with finite range at most $\ell > 0$ is well decorrelated, since $\theta_f(n, d) = 0$ for all $\ell < d < n$. In particular, so is Bernoulli percolation. For Gaussian fields, being well decorrelated is a consequence of a fast enough decay of the correlation function, see Corollary 3.4. For the Ising model, it can be obtained as a consequence of a ‘‘coupling from the past’’ construction, see Theorem 3.5.

As far as we know, these two results of quantitative decorrelation are new. They are of separate interest and their proofs are independent of the rest of the paper.

1.2. Topological definitions. The complexity of some of the following is due to unpleasant and numerous minor technicalities that fatally pervade percolation arguments because of the discrete nature of the arguments. For a first reading, we advise the reader to keep the classical definitions in mind; we will point out below some of the reasons for our particular variants.

Definition 1.5. *Let \mathcal{T} be a symmetric lattice.*

- A strongly simple path (resp. strongly simple circuit) γ is a finite sequence $(\gamma_i)_{i \in \{1, \dots, k\}}$, $k \geq 1$ (resp. $(\gamma_i)_{i \in \mathbb{Z}/k\mathbb{Z}}$, $k \geq 4$) of vertices of \mathcal{T} , such that for all i, j , γ_i is a neighbour of γ_j if and only if $i - j = \pm 1$.
- A quad is quadruple $Q = (\gamma, \gamma_1, \gamma', \gamma_2)$, where $\gamma, \gamma_1, \gamma', \gamma_2$ are disjoint paths, such that $\gamma \cup \gamma_1 \cup \gamma' \cup \gamma_2$ forms a strongly simple circuit. Given a quad Q , we will denote by ∂Q this circuit, and by Q° the discrete bounded connected component of $\mathcal{V} \setminus \partial Q$. By an abuse of notation, we will write $v \in Q$ to mean $v \in Q^\circ \cup \partial Q$. By another abuse of notation, we will denote by (U, γ, γ') the quad $(\gamma, \gamma_1, \gamma', \gamma_2)$ where $U = Q^\circ \cup \partial Q$.
- A (horizontal) rectangle is a quad of the form $([a, b] \times [c, d], \{a\} \times [c, d], \{b\} \times [c, d])$, where $a, b, c, d \in \mathbb{Z}$ with $a < b$ and $c + 1 < d$. In particular, for $a, b \in \mathbb{N}^*$, define the rectangle $R_{a,b} := [0, a] \times [0, b]$ and the associated quad

$$\mathcal{R}_{a,b} := (R_{a,b}, \{0\} \times [0, b], \{a\} \times [0, b]).$$

- For any strongly simple path (resp. circuit) $c = (c_i)$ and any $n \in \mathbb{N}^*$, we can define nc the strongly simple path (resp. circuit) obtained by connecting the vertices nc_i by straight paths in \mathcal{T} . For any $n \in \mathbb{N}^*$ and any quad $Q = (\gamma, \gamma_1, \gamma', \gamma_2)$, nQ denotes the quad $(U', n\gamma, n\gamma')$, where U' is characterized by $\partial(nQ) = n(\partial Q)$.
- For any quad $Q = (\gamma, \gamma_1, \gamma', \gamma_2)$, Q^* denotes the quad $(\gamma_1, \gamma', \gamma_2, \gamma)$.
- A horizontal crossing (or simply a crossing for short) of a quad $Q = (U, \gamma, \gamma')$ is a strongly simple path c in U joining a point x adjacent to γ to a point y adjacent to γ' , such that the only vertices in c which are adjacent to ∂U are x and y , with the additional condition that x and y themselves are at distance at least two from $\gamma_1 \cup \gamma_2$. A vertical crossing of Q is a crossing of Q^* .
- If A denotes a subset of \mathcal{V} , we say that A crosses the quad Q or is a crossing of Q if there exists a crossing of Q which is contained in A . For any radii $0 < r < R$, we say that A surrounds the annulus $A(r, R) := [-R, R]^2 \setminus [-r, r]^2$ if there exists a strongly simple circuit contained in $A \cap A(r, R)$ which is a generator of $\pi_1(A(r, R))$. A traversing of $A(r, R)$ is a strongly simple path $c \subset A(r, R)$ such that the extremities of c lie in the boundary components $C(r) := \partial[-r, r]^2$ and $C(R) := \partial[-R, R]^2$, respectively.

Remark 1.6. *Note that a crossing of a quad Q does not have any vertex in ∂Q .*

The notion of strongly simple path may deserve some additional comment. It is common when working with percolation to consider *simple paths* (i.e., nearest-neighbor paths never

visiting the same vertex twice), especially when working with product measures. Here we will rely on a discrete version of the Jordan theorem, stating that a path separates its complement into two connected components: this does not hold in the case of a general simple path, because nothing prevents it from visiting a neighbor of itself and thus closing a “bubble”. Strongly simple paths are exactly paths for which this does not happen. The restriction is not serious in practice, because every path contains a strongly simple sub-path:

Definition 1.7. Let $\gamma = (\gamma_i)_{i \in \{1, \dots, k\}}$ be a nearest-neighbor path in \mathcal{T} : the (strong) loop-erasure of γ is the strongly simple path $LE(\gamma) := (\gamma'_i)$ defined inductively by letting $l_1 = 1$, $\gamma'_1 = \gamma_1$ and

$$l_{i+1} = \max \{j > l_i : \gamma_j \sim \gamma'_i\}, \quad \gamma'_{i+1} = \gamma_{l_{i+1}}$$

as long as the set over which the max is taken is non-empty.

Definition 1.8. Let \mathcal{T} be a symmetric lattice and f be a random function over \mathcal{V} . For any realization of f , a quad Q is said to be positively crossed (or simply crossed for short for unambiguous situations, alternatively we will sometimes say that f crosses Q) if Ω^+ crosses Q . The process (f, \mathcal{T}) is said

- to satisfy the box-crossing property (BXP for short) if for any horizontal rectangle R , there exists $c > 0$, such that for any $n \in \mathbb{N}^*$ large enough, with probability at least c , nR is positively crossed;
- to satisfy the strong box-crossing property (SBXP for short) if for any quad Q (resp. any annulus A), there exists $c > 0$, such that for any $n \in \mathbb{N}^*$ large enough, with probability at least c , nQ is positively crossed (resp. Ω^+ surrounds nA);
- to be well behaved if it satisfies the condition given by Definition 2.4.

Remark 1.9. In the Bernoulli percolation literature, the one-arm estimate is a direct consequence of the box-crossing property; it states that the annulus $A(r, R)$ is surrounded with probability at least $1 - C(r/R)^c$ for some $c > 0$. This implies that Bernoulli percolation is well behaved (Theorem 1.14 below), but the implication is not true in the more general setup of dependent models due to the influence of quad boundaries.

A first essential relation between these definitions is the following:

Proposition 1.10. If the symmetric process (f, \mathcal{T}) is well behaved and well decorrelated, then it satisfies the BXP and the SBXP.

Remark 1.11. For a process satisfying the FKG inequality, the SBXP is a direct consequence of the BXP using standard percolation arguments. In the particular case of critical Bernoulli percolation, the usual proofs of the BXP are simpler and the fact that the model is well behaved is obtained as a consequence of the BXP, see Theorem 1.14, rather than as the main proof step as will be the case below.

Our main theorem is the following:

Theorem 1.12. Let \mathcal{T} be a symmetric lattice, and $(f_u)_{u \in [0,1]}$ be a continuous family of symmetric, uniformly well decorrelated random sign functions over \mathcal{T} such that (f_0, \mathcal{T}) is well behaved. Then there exists $u_0 > 0$ such that, for any $u \in [0, u_0]$, (f_u, \mathcal{T}) is well behaved (and hence satisfies the SBXP).

Remark 1.13. At a more abstract level, this theorem can be restated to assert that given a continuous collection $(f_u)_{u \in \mathcal{U}}$ of uniformly well decorrelated models, the set of parameters for which good behavior holds is open. It would be desirable to show that, under appropriate assumptions, it is also closed, since that would lift our result into a non-perturbative theorem. Unfortunately, our proof cannot be extended as is, because the good behavior condition itself is not closed; here is a counter-example, described in an informal fashion.

Split the Union-Jack lattice into mesoscopic $N \times N$ squares, let f_0 be Bernoulli percolation on the initial lattice and f_1 be Bernoulli percolation conditioned to take the same sign at all the vertices of any of the mesoscopic squares (“coarse-grained percolation”). Then, for every $u \in [0, 1]$, at every vertex v toss a Bernoulli random variable ε_v with parameter u and set $f_u(v) = \varepsilon_v f_1(v) + (1 - \varepsilon_v) f_0(v)$. The collection (f_u) is uniformly well decorrelated (and in fact, uniformly of finite range), but f_u is only well behaved for $u < 1$. Note though that f_1 does satisfy the SBXP.

The following classical theorem asserts that Theorem 1.12 applies to any well decorrelated perturbation of critical Bernoulli percolation:

Theorem 1.14 (Russo [17], Seymour–Welsh [18], Kesten [12]). *If f denotes critical Bernoulli percolation on \mathcal{T} , then (f, \mathcal{T}) is well behaved.*

The two main applications of Theorem 1.12 which we mention below are Gaussian fields with fast decaying (but not necessarily positive) correlation, and the high-temperature (but possibly antiferromagnetic) Ising model.

1.3. Gaussian fields. For any lattice \mathcal{T} , recall that the correlation function e of a random field $f : \mathcal{V} \rightarrow \mathbb{R}$ with expectation 0 is defined by $e(x, y) = \mathbf{E}(f(x)f(y))$ for any $(x, y) \in \mathcal{V}^2$. We already used in [1] the following natural decay condition:

$$(1.1) \quad \exists C, D > 0, \forall x, y \in \mathcal{V}, |e(x, y)| \leq C \|x - y\|^{-D}.$$

We say that a family $(f_u)_{u \in [0, 1]}$ of Gaussian fields uniformly satisfies condition (1.1) if the constants C and D can be chosen independently of u .

Theorem 1.15 (Theorem 4.7 in [1], see also [19, 2, 16]). *Let \mathcal{T} be a symmetric lattice and f be a symmetric Gaussian field on \mathbb{R}^2 such that its correlation function is non-negative and satisfies condition (1.1) for $D > 16$. Then the process (f, \mathcal{T}) satisfies the strong box-crossing property.*

The proof of this theorem made a crucial use of the FKG condition, which is implied by the positivity of the correlation function. The condition was needed in the argument of Tassion [19], which we used in [1]. In the present paper, thanks to the strong decay of correlation, we are able to remove the positivity assumption for perturbations of models that satisfy the strong box-crossing property. We emphasize that the proofs of Theorems 1.12 and 1.16 are independent of [1]. In particular, the percolation arguments of the proofs in this paper are new and do not use [19].

Theorem 1.16. *Let \mathcal{T} be a symmetric lattice, and $(f_u)_{u \in [0, 1]}$ be a continuous family of symmetric random Gaussian fields over \mathcal{V} uniformly satisfying condition (1.1) for $D > 24$. Assume that the process (f_0, \mathcal{T}) is well behaved. Then there exists $u_0 \in (0, 1]$ such that (f_u, \mathcal{T}) is well behaved and satisfies the strong box-crossing property for each $u \in [0, u_0]$.*

One notable special case comes when considering f_0 to be the i.i.d. symmetric Gaussian field on \mathcal{T} . Then, its sign is exactly critical Bernoulli percolation, for which good behavior is known:

Corollary 1.17. *For any symmetric Gaussian field f independent of f_0 and satisfying the condition (1.1) for $D > 24$, there exists $u_0 > 0$, such that for any $u \in [0, u_0]$, $uf + \sqrt{1 - u^2} f_0$ is well behaved and satisfies the strong box-crossing property.*

Note that for any $u > 0$ and any pair (x, y) of distinct vertices, the correlation function of $uf + \sqrt{1 - u^2} f_0$ equals $u^2 e$, where e is the correlation function of f . If e is oscillating, this gives non-trivial examples of RSW for fields with oscillating correlation function; see the appendix for an explicit computation related to the random wave model.

1.4. The Ising model. On a periodic lattice \mathcal{T} with vertex set \mathcal{V} , the Ising model with inverse temperature β , which is one of the most studied models of statistical mechanics, is a probability measure on the space of configurations $\Omega := \{-1, 1\}^{\mathcal{V}}$ defined as follows. First, given a finite region $\Lambda \subset \mathcal{V}$ and a configuration $\omega \in \Omega$, seen as a boundary condition, a Hamiltonian is defined on $\{-1, 1\}^{\Lambda}$ by

$$\mathcal{H}_{\Lambda}^{\omega}(\sigma) := - \sum_{\substack{i, j \in \Lambda \\ i \sim j}} \sigma_i \sigma_j - \sum_{\substack{i \in \Lambda, j \in \Lambda^c \\ i \sim j}} \sigma_i \omega_j$$

(recall that the notation $i \sim j$ means that the vertices i and j are adjacent). The Ising measure on $\{-1, 1\}^{\Lambda}$ with boundary condition ω and inverse temperature β is given by

$$\mu_{\Lambda, \beta}^{\omega}[\{\sigma\}] := \frac{1}{Z_{\Lambda, \beta}^{\omega}} \exp(-\beta \mathcal{H}_{\Lambda}^{\omega}(\sigma)),$$

where the *partition function* $Z_{\Lambda, \beta}^{\omega}$ is chosen to make $\mu_{\Lambda, \beta}^{\omega}$ a probability measure. One can then try to define a measure μ_{β}^{ω} on Ω by taking a thermodynamic limit as Λ increases to the whole space. Notice that for $\beta = 0$, the model degenerates to Bernoulli site percolation.

When $\beta > 0$, the model is known as *ferromagnetic* and is very well understood. It satisfies the FKG inequality, which allows to take the thermodynamic limit for $+$ or $-$ boundary conditions; it exhibits a phase transition at a *critical parameter* $\beta_c > 0$: for $\beta \in [0, \beta_c]$ the limit μ_{β}^{ω} exists and is independent of ω , while for $\beta > \beta_c$ the two limits μ_{β}^{+} and μ_{β}^{-} still exist but are different. The SBXP is known to hold in the high-temperature regime $\beta \in [0, \beta_c]$ (e.g. as a consequence of Tassion [19], see also [7]).

Our main focus will be in the antiferromagnetic case $\beta < 0$. There, it is still true that the thermodynamic limit exists and does not depend on the choice of ω , provided $|\beta|$ is small enough (this follows from the Dobrushin uniqueness condition, or from the explicit “coupling from the past” construction that we use below), and we can omit ω from the notation.

Theorem 1.18. *Let \mathcal{T} be a symmetric lattice. Then there exists $\beta_0 > 0$ such that, for every $\beta \in (-\beta_0, \beta_0)$, the Ising model on \mathcal{T} at inverse temperature β is well behaved and satisfies the SBXP.*

1.5. Open questions. There are several natural directions in which our results might possibly be extended:

- First, by generalizing them to be non-perturbative (in other words, by proving that the conclusion of Theorem 1.12 holds for all $u \in [0, 1]$). The main part of our argument, culminating in Theorem 2.7, does hold uniformly, and in fact is independent of the perturbative setup, so only the very last step of the argument should need to be extended. See however Remark 1.13: additional hypotheses (probably along the lines of finite energy) will be needed for good behavior to be a closed condition.
- Second, we believe that our method should hold for smooth Gaussian fields defined on the whole plane. Indeed in [1] we used a discretization scheme which allowed us to leverage discrete arguments to the continuous setup; a similar process might be applicable here. Note however that the issue of boundary conditions for random quads is a significant obstacle: for the discretization of a smooth field, the boundary of an explored quad with negative boundary condition comes with an inner “coating” of negative vertices, so our conditions on β cannot be expected to hold in as much generality.
- Finally, it would be very useful to improve the bounds on the degree of covariance decay D under which the argument works, with a long-term goal of addressing

the case of monochromatic waves (for which $D = 1/2$). This however will require either a completely new argument, or significant changes to each of our estimates.

2. PROOF OF THE MAIN RESULT

As before, in this whole section \mathcal{T} is a symmetric lattice and f is a random field on \mathcal{T} with values in $\{\pm 1\}$. We will not always assume that f is symmetric under sign-change, because this will not be necessary for the statement of our main theorem and besides some of the models to which we want to apply our construction are not themselves symmetric. Instead, the partial symmetry assumption we will make comes in the form of *a priori* estimates on square crossing probabilities (uniform lower bounds on m_n with the notation below). The gist of the argument is the same in both cases, so for a first reading it might help to assume self-duality everywhere and replace m_n with $1/2$ in what follows.

We begin with the concept of *well behaved* random processes, which roughly means that (random) quads discovered from the outside are crossed with a probability quantitatively linked to the largest modulus of the annuli they traverse.

2.1. Well behaved processes. The following notions mimic that of stopping times in a geometric setup:

Definition 2.1 (Explorability). *Let $1 \leq L$. A random topological disc $Q \subset \Lambda_L$ is said to be*

- *explorable from its interior if for any deterministic $V \subset \Lambda_L$, the event $\{Q = V\}$ belongs to the σ -algebra generated by the restriction of f to V .*
- *explored from its outside within Λ_L if for any deterministic $V \subset \Lambda_L$, the event $\{Q = V\}$ belongs to the σ -algebra generated by the restriction of f to $\Lambda_L \setminus V^\circ$.*

It is a subtle but crucial point in the definition that exploration needs to happen within a fixed, deterministic box Λ_L : indeed, the couplings we construct later only hold in finite domains, and more generally it can happen that knowing the field in the whole lattice outside a finite quad somehow gives “too much information”. Note though that if f has finite range ℓ (see Definition 1.4), then for any random subset V of Λ_L explored from its outside within Λ_L , $f|_{V \setminus (\partial V)_\ell}$ is independent of $f|_{V \setminus V}$, so the dependence on L is much weaker in this case. See also Lemma 2.25 for a statement of “automatic uniformity in the exploration domain.”

Definition 2.2 (Quads with prescribed geometry). *For $1 \leq r \leq R \leq L \leq L'$, we will repeatedly use the following collections of quads:*

- $\mathcal{Q}_{r,R,L}$ *will denote the set of all quads $Q \subset \Lambda_L$ which satisfy the condition that, for some $x \in \Lambda_L$, any crossing of Q traverses $x + A(r, R)$. Note that in particular the set $\mathcal{Q}_{r,R,L}$ contains all the quads in Λ_L with one boundary arc inside the ball $x + \Lambda_r$ and the other outside $x + \Lambda_R$.*
- $\mathcal{Q}_{r,R,L,L'}$ *will denote the collection of all the random quads, explored from their outside within $\Lambda_{L'}$, that are almost surely in $\mathcal{Q}_{r,R,L}$ (formally, it is a collection of random variables taking values in $\mathcal{Q}_{r,R,L}$).*

Sometimes, when it does not lead to ambiguities, we will allow ourselves to drop the last indices from the notation, writing that a random quad is in $\mathcal{Q}_{r,R,L}$ if it is clear from the context where the exploration occurs, or that a quad is in $\mathcal{Q}_{r,R}$ if the box Λ_L that contains it either does not matter or is again clear from the context.

Definition 2.3 (Well behaved processes). *For any realization of f , a (possibly random) quad $Q \in \mathcal{Q}_{r,R,L,L'}$ is said to be glued if it is vertically crossed by a positive path. Let*

$$\beta_f(r, R, L, L') := \sup_{Q \in \mathcal{Q}_{r,R,L,L'}} \mathbf{P}[Q \text{ is not glued} \mid f|_{\Lambda_{L'} \setminus Q}].$$

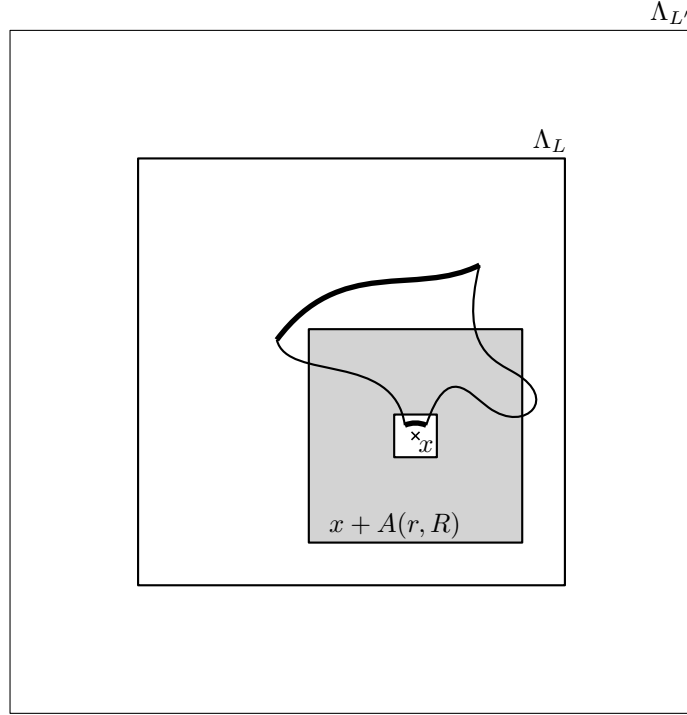

FIGURE 1. A quad in $\mathcal{Q}_{r,R,L,L'}$: the quad is contained in Λ_L , explored in $\Lambda_{L'}$ and crosses the annulus $x + A(r, R)$. Note that although it is the case in the figure and it is the origin of the notation and much of the geometric intuition, the definition of $\mathcal{Q}_{r,R,L,L'}$ does not impose that the arcs γ and γ' are disjoint from the annulus $x + A(r, R)$, see Figure 3 for a more generic example.

For $\lambda > 0$ and $1 \leq L \leq L'$, we say that the model f is (λ, L, L') -well behaved if it satisfies

$$\forall 1 \leq r \leq R \leq L \quad \beta_f(r, R, L, L') \leq \lambda(r/R)^{1/\lambda}.$$

Definition 2.4. For $1 \leq r \leq R \leq L$, let

$$\beta_f(r, R, L) := \sup_{L' \geq L} \beta_f(r, R, L, L').$$

We say that the process is (λ, L) -well behaved if it is (λ, L, L') -well behaved for all $L' \geq L$, which means that $\beta_f(r, R, L) \leq \lambda(r/R)^{1/\lambda}$; that it is λ -well behaved if it is (λ, L) -well behaved for all $L \geq 1$, and that it is well behaved if it is λ -well behaved for some $\lambda > 0$.

We will denote by $\text{WB}_f(\lambda, L, L')$ the assertion that f is (λ, L, L') -well behaved (to which we will refer as the *good behavior* of f), and similarly use $\text{WB}_f(\lambda, L)$, $\text{WB}_f(\lambda)$, and WB_f .

Remark 2.5. Note that we chose our precise definitions in such a way that a quad Q can be glued even if f is negative on ∂Q ; see Remark 1.6.

The fact that critical Bernoulli percolation is well behaved (Theorem 1.14 above) is a consequence of classical polynomial upper bounds on the probability of one-arm events (see e.g. [8, Theorem 11.89]) and duality: the absence of a vertical gluing of the quad $Q \in \mathcal{Q}_{r,R}$ implies the existence of a negative horizontal crossing of Q , which has probability at most $(r/R)^c$ for a universal $c > 0$.

Before going on, we introduce for further reference a direct continuity property of being well behaved at a fixed scale, which we give without proof.

Lemma 2.6. For any $\lambda > 0$, $L' \geq L \geq 1$ and any continuous family $(f_u)_{u \in [0,1]}$ of random fields on \mathcal{T} such that f_0 is (λ, L, L') -well behaved, there exists $u_0 > 0$ such that for any $u \in [0, u_0]$, f_u is $(2\lambda, L, L')$ -well behaved.

The main point of our approach is the following finite size criterion:

Theorem 2.7. *Fix $C > 0$ and $\beta > 2\alpha > 0$, define η , c , ε , λ^* and N as in Lemma 2.26, and let*

$$\forall \lambda \geq \lambda^*, \bar{N}(\lambda, \varepsilon, \eta) := \max \left(N(3\lambda, \varepsilon, \eta), (4/3)^{\lambda/\eta} \right).$$

Then, whenever f is a self-dual, well decorrelated field (with constants C , α , β),

$$\forall \lambda \geq \lambda^*, \forall n \geq \bar{N}(\lambda, \varepsilon, \eta), \quad \text{WB}_f(\lambda, n, n^c) \implies \text{WB}_f.$$

Assuming this and Proposition 1.10, we can already give the proof of Theorem 1.12.

Proof of Theorem 1.12. Let λ^* , ε , η and c be given by Theorem 2.7. Since f_0 is well behaved, there exists $\lambda > \lambda^*$ such that for any $n \in \mathbb{N}^*$, f_0 satisfies $\text{WB}_{f_0}(\lambda, n, n^c)$. Fix $n \geq \bar{N}(2\lambda, \varepsilon, \eta)$ for the remainder of the proof. By Lemma 2.6, there exists $u_0 \in (0, 1]$ such that for any $u \in [0, u_0]$, f_u satisfies $\text{WB}_{f_u}(2\lambda, n, n^c)$. Therefore, by Theorem 2.7, f_u is well behaved for all $u \in [0, u_0]$; by Proposition 1.10, it therefore satisfies the SBXP. \square

2.2. Ideas of the proof of Theorem 2.7. The proof follows some of the usual arguments of Russo-Seymour-Welsh theory, but every application of the Harris-FKG inequality needs to be replaced with a quantitative error estimate coming from the good behavior of f .

In Section 2.4, we begin with the easier case where f has finite rang at most $\ell > 0$. We first show how to derive the box-crossing property for a discrete field from the fact that f is well behaved. Two positive crossings happen simultaneously with positive probability if they happen in quads distant from each other by at least $\ell > 0$; then, good behavior at small scale can be used as a tool to connect crossings. A sequence of lemmas gives crossing probabilities for more and more complex shapes, from Lemma 2.17 (the shape "L") to Lemma 2.24 (general quads). The last one gives a simpler version of Theorem 2.7, namely Theorem 2.16 which asserts that if β_f is small enough on a well chosen scale, then f is well behaved for larger scales.

In Section 2.5, we tackle the general case. For this, at any scale n we couple the field f with a field g with finite range at most n^ε , where $\varepsilon < 1$, so that the total variation distance between f and g is very small. We then apply Theorem 2.16 for g to reach a higher scale and come back to f , to implement a scale recursion for f .

2.3. Topological preliminaries. Before entering the main part of the proof, we first state a few topological lemmas that we will use repeatedly. We provide proofs for completeness, but all the following statements are very natural.

Lemma 2.8 (Jordan Theorem for quads). *Let c be a strongly simple crossing of a quad $Q = (U, \gamma_1, \gamma_2)$. Then $U \setminus (c \cup \partial U)$ is the union of two connected components V_1 et V_2 , each of which being the interior of a quad whose boundary is contained in $c \cup \partial U$ (cf. Figure 2).*

Proof. Let $\tilde{\partial}U$ (resp. \tilde{c}) denote the continuous path associated to ∂U (resp. c). Then, $\tilde{\partial}U$ (resp. \tilde{c}) is a topological circle (resp. a topological segment). By the Jordan-Schoenflies Theorem, it bounds an open topological disc \tilde{U} . By adding two edges v and w , \tilde{c} can be extended to a segment with extremities in $\tilde{\partial}U$. Then, again by the Jordan-Schoenflies, $\tilde{U} \setminus \tilde{c}$ has two connected components \tilde{V}_1 and \tilde{V}_2 which are topological discs. They define two discrete subsets V_1 and V_2 of \mathcal{V} that are connected in \mathcal{T} . Moreover $\tilde{\partial}Q \setminus \{v, w\}$ defines two strongly simple paths c_1 and c_2 , so that the discrete boundary of V_i is formed by the strongly simple cycle $(c_i \cap \gamma, \gamma_i, c_i \cap \gamma', c)$ (up to loop erasure around v and w). For $i = 1, 2$, this defines the quad Q_i . \square

Let $Q = (U, \gamma, \gamma_1, \gamma', \gamma_2)$ be a quad strongly crossed by a path c . We denote by V_c the connected component Q_1 (remember that we sometimes identify the quad and its geometric support) of Lemma 2.8 which contains γ_1 .

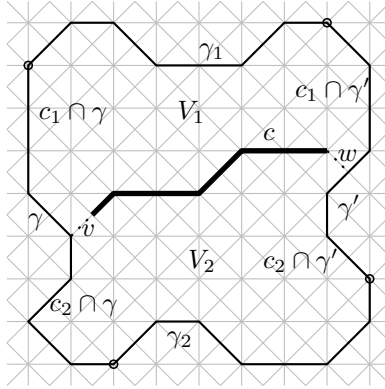

FIGURE 2. The discrete Jordan theorem for quads.

Lemma 2.9 (Order for strong crossings). *Let $Q = (U, \gamma, \gamma')$ be a quad. There exists an partial order \leq on the set of strong crossings of Q defined by $c \leq c'$ iff $V_c \subset V_{c'}$.*

Proof. The relation \leq is clearly reflexive and transitive. For proving antisymmetry, let us first prove that c is the subset of V_c consisting of the vertices which have a neighbour outside V_c . For this, let $x \in c$, such that x is not an extremity of c . Its two neighbours in c are not linked in \mathcal{T} since c strongly simple. If $x \in c$ is an extremity, it is adjacent to a point of ∂Q , which cannot be at distance one to the neighbour of x in c . Since \mathcal{T} is a triangulation, this implies that x has a neighbour outside V_c . Now, if $V_c = V_{c'}$ and $x \in c$, then there is a neighbour of x outside $V_c = V_{c'}$. Moreover $x \in V_c = V_{c'}$ so that by the first point, $x \in c'$. \square

Lemma 2.10 (Leftmost crossing). *Let Q be a random quad. Under the condition that is positively strongly crossed, that is Ω^+ crosses Q , there exists a unique positive strongly simple crossing Γ^- of Q that is minimal (among such crossings) for the order defined in Lemma 2.9.*

Proof. First, let us prove the following claim: if c and c' are two positive strong crossings of Q , then there exists c'' a strong crossing of Q such that $c'' \leq c'$ and $c'' \leq c$, with $c'' \subset c' \cup c$. Indeed, define

$$\Delta = \{x \in c \cup c' \mid \text{there is a path in } \{x\} \cup (c \cup c')^c \text{ joining } x \text{ to } \gamma_1\},$$

where $Q^* = (U, \gamma_1, \gamma_2)$. Let us prove that Δ crosses U , so that it crosses U positively, since c and c' are positive. Indeed, let δ be a vertical crossing of U which we orient from γ_1 to γ_2 . It must cross c and c' and the first meeting point belongs to Δ . Moreover, $\Delta \subset V_c \cap V_{c'}$. Indeed, for any $x \in \Delta$, there exists a path k from x to γ_1 in $\{x\} \cup (c \cup c')^c$. Then, k lies in $V_c \cap V_{c'}$, so that $x \in V_c \cap V_{c'}$. Now, there exists a crossing path c'' of Q in Δ ; by loop erasure, it gives a simple crossing. It is in fact a strongly simple path since it is included in $c \cup c'$. This proves the claim.

Now, there can only be a finite number of strongly crossings, so that by a finite induction the claim provides the existence of a minimal element. Uniqueness is a consequence of the antisymmetry of the order. \square

Lemma 2.11 (Hereditiy of explorability).

- If Q is a fixed deterministic quad and it is positively crossed, let Γ^- be its lowest positive crossing given by Lemma 2.10. Then, V_{Γ^-} given by Lemma 2.9 is explorable from its interior.
- If Q is random and explored from its exterior in Λ_L , then $Q \setminus V_{\Gamma^-}$ is explored from its exterior too.

Proof. For any strongly crossing c of Q , the event $\{\Gamma^- = c\}$ depends only on the restriction of the process on V_c since the points of c are linked by closed paths to the bottom γ_1 of Q ($Q^* = (U, \gamma_1, \gamma_2)$). By definition these paths are in V_c , so that knowing the process on V_c is sufficient to define Γ^- . \square

Recall that for any subset U of \mathcal{V} and any $r > 0$, U_r denotes the set of vertices that are within distance r of U .

Lemma 2.12 (Tubular neighbourhood of a crossing). *Let Q be a quad and $\ell > 1$. Then conditioning that Q is crossed, let Γ^- be its lowest crossing, and define*

$$\Delta_\ell = \{x \in (V_{\Gamma^-})_\ell \mid x \text{ has a neighbour in } U \setminus (V_{\Gamma^-})_\ell\}.$$

Then Δ_ℓ crosses Q .

Proof. It is enough by duality to show that any vertical crossing has to intersect Δ_ℓ ; so let c be vertical crossing of Q . Then c intersects $(V_{\Gamma^-})_\ell$ since it intersects V_{Γ^-} . Let $x \in c$ be the first point in $(V_{\Gamma^-})_\ell$: then $x \in \Delta_\ell$. \square

Lemma 2.13 (Crossing of an almost square). *Let \mathcal{T} a symmetric triangulation carrying a symmetric field f . Then any almost-square $[0, n] \times [0, n+4]$ is crossed by f with probability $1/2$.*

Proof. With the usual definition of crossing, in any quad (by planar duality) either there is a horizontal crossing made of vertices where f is positive, or there is a vertical crossing made of vertices where f is negative. If the shape of the quad is symmetric and f is invariant in distribution under sign change, these two events have the same probability, hence have probability $1/2$. Our particular definition, where we require crossings to be strongly simple and to stay a few vertices away from the boundaries, lends itself to the same analysis, the only difference being that self-dual domains are not exactly squares anymore, hence the offset by 4 in one direction. \square

Recall that for any $r > 0$, $C(r)$ denotes the exterior boundary of $\Lambda_r = [-r, r]^2$.

Lemma 2.14 (Subquad in an annulus). *For $r < R \leq L$, let $Q = (U, \gamma, \gamma')$ be a quad in $\mathcal{Q}_{r,R,L}$ with dual $Q^* = (U, \gamma_1, \gamma_2)$. Then (cf. Figure 3) there exists $x \in \Lambda_L$ and a quad $Q' = (U', a, a') \in \mathcal{Q}(r, R, L)$ with dual $(Q')^* = (U', b, b')$, such that $U' \subset U$, $a \subset x + C(r)$, $a' \subset x + C(R)$, and $b \subset \gamma_1$, $b' \subset \gamma_2$. In particular, any gluing of Q' is a gluing of Q .*

Proof. Let x be given by Definition 2.2, so that any path in U from γ to γ' crosses $x + A(r, R)$. Denote by C_r (resp. C_R) the set of connected components of $(x + C(r)) \cap U$ (resp. $(x + C(R)) \cap U$) such that c is contained in C_r (resp. C_R) and separates γ from γ' . These two collections are not empty, since from the definition of $\mathcal{Q}_{r,R}$, C_r (resp. C_R) itself separates γ from γ' . Moreover, any of these connected components is a segment with one extremity in γ_1 and the other in γ_2 .

Now, γ_1 crosses any element of $C_r \cup C_R$. In particular, there exists $c \in C_r$, $c' \in C_R$, such that γ_1 crosses c and then c' (or the inverse, depending on the orientation chosen on γ_1). The arcs c and c' together with the parts of γ_1 and γ_2 between them define a quad satisfying the required conditions. \square

Lemma 2.15 (Order on the boundary of a quad). *Let U be a topological disc with piecewise smooth boundary, a, b, c and d be distinct points in ∂U such that there exist two disjoint paths γ and γ' with extremities, respectively, a and b , and c and d . Then the points on ∂U follow the cyclic order a, b, c, d , up to swapping (a, b) or (c, d) . In other words, the pairs (a, b) and (c, d) are not intertwined along ∂U . \square*

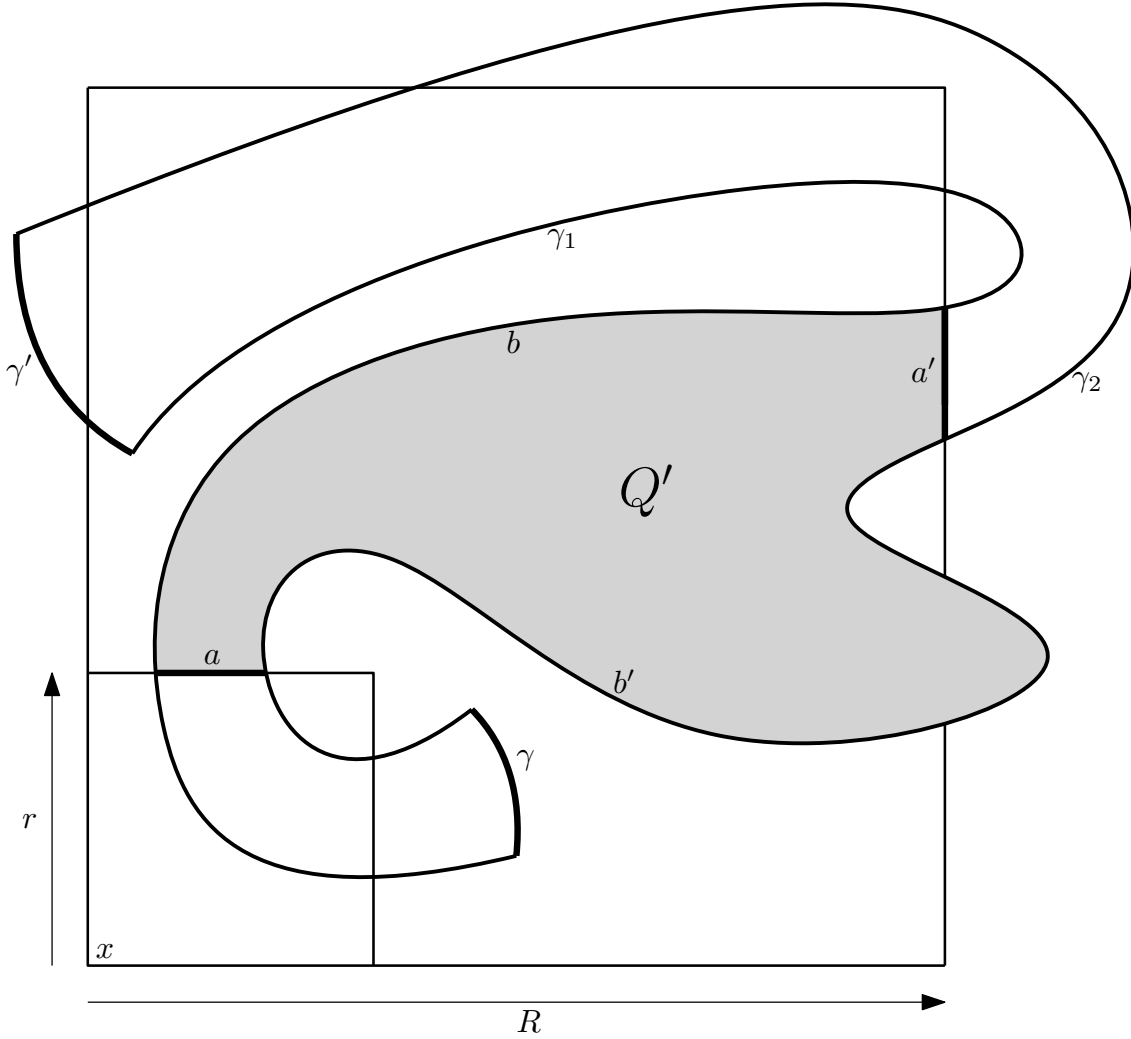

FIGURE 3. Subquad in an annulus. Notice that Q' need not be contained in the annulus $x + A(r, R)$, only its boundary arcs a and a' are required to be on the annulus boundary.

2.4. Finite-range models. In all this section, we will consider the simpler case of discrete models with finite range, see Definition 1.4, so we assume the existence of $\ell < \infty$ such that, whenever A and B are vertex sets separated by a distance at least equal to ℓ , the restrictions $f|_A$ and $f|_B$ are independent. The dependency in ℓ of constants appearing in the estimates below will be made explicit, the constants are otherwise universal. We will prove that under an initializing assumption, finite range fields are well behaved and satisfy the SBXP:

Theorem 2.16. *Let f be a self-dual field with range less than $\ell > 0$ on a symmetric lattice \mathcal{T} , and $L > 0$. Assume that there exist $\ell_3 > \ell_2 > \ell_1 > 8\ell + 24$ such that*

$$\beta_f(2\ell, \ell_1, \ell_3, \ell_3 + \ell) + \beta_f(\ell_1, \ell_2, \ell_3, \ell_3 + \ell) < 2^{-1401}.$$

Then

$$\forall 2\ell_2 < r < R < L \leq L + \ell \leq L', \quad \beta_f(r, R, L, L') \leq (8r/R)^{2^{-1397}}.$$

Moreover, f is well behaved and satisfies the SBXP.

A crucial remark is that for ℓ -dependent models, knowledge of the configuration outside Λ_L or in any annulus $A(L, L')$ for $L' \geq L + \ell$ give the same amount of information on the

model within Λ_L . In other words, as soon as $L', L'' \geq L + \ell$,

$$\beta_f(r, R, L, L') = \beta_f(r, R, L, L'')$$

for all $1 \geq r \geq R \geq L$. This means in turn that the conditions $\text{WB}_f(\lambda, L)$ and $\text{WB}_f(\lambda, L, L')$ are equivalent for $L' \geq L + \ell$. As a consequence, in this whole subsection we will not always mention in which box quads are explored, since the estimates we will obtain are independent of it; in this case $\beta_f(r, R, L)$ is the common value of the $\beta_f(r, R, L, L')$ for $L' \geq L + \ell$.

If Q is a quad, we will denote by $\pi(Q)$ the probability that f crosses Q . Our first statement is representative of typical inequalities for percolation (note that it would be trivial, with no error term, if the field f satisfied the FKG inequality):

Lemma 2.17 (Rectangle to L). *For any $0 < l < L'$ and $0 < l' < L$ with $L' \leq L$ and*

$$2\ell < \delta := \min\left(\frac{1}{4}l, \frac{1}{2}(L - l')\right),$$

define two overlapping rectangles $R = [0, L] \times [0, l]$ and $R' = [L - l', L] \times [0, L']$ and the quads

$$\begin{aligned} \mathcal{R} &= (R, \{0\} \times [0, l], \{L\} \times [0, l]), \\ \mathcal{R}' &= (R', [L - l', L] \times \{0\}, [L - l', L] \times \{L'\}), \\ \mathcal{L} &= (R \cup R', \{0\} \times [0, l], [L - l', L] \times \{L'\}) \end{aligned}$$

(cf. Figure 4). Then,

$$(2.1) \quad \pi(\mathcal{L}) \geq \pi(\mathcal{R})\pi(\mathcal{R}') - 2\beta_f(2\ell, \delta, L).$$

Before giving the formal proof, we would like to explain the idea in an idealized situation. First, with probability at least $\pi(\mathcal{R}')$, there exists a vertical crossing of \mathcal{R}' . We choose the rightmost crossing, defining at its right a quad V . Denote its ℓ -tubular neighbourhood by V_ℓ . Then, the restriction of f on the left side of V_ℓ in \mathcal{L} is independent of f on V , so that with probability at least $\pi(\mathcal{R})\pi(\mathcal{R}')$, there is a horizontal crossing in \mathcal{R} from its left side to the left boundary of V_ℓ . Now, let us choose the lowest such crossing and assuming it touches V_ℓ at a point in the lower horizontal half of \mathcal{R} . Then, the part of \mathcal{L} above this crossing, together with a small path from this point to V is a quad explorable from its exterior which lies in $\mathcal{Q}(\ell, l/2, L, L + \ell)$, so that by definition of β_f , it is glued with probability at least $1 - \beta_f(\ell, l/2, L)$. Summarizing, with probability at least $\pi(\mathcal{R})\pi(\mathcal{R}') - 2\beta_f(\ell, l/2, L)$, \mathcal{L} is crossed, the factor 2 coming from the other case where we choose the highest horizontal crossing.

Unfortunately, writing down the details of the proof induces some unpleasant technicalities and complexity. The detailed proof below can be skipped on first reading, as it brings no additional intuition; for the subsequent lemmas, we will not write the demonstrations with as much detail, because most of the techniques will be very similar.

Proof of Lemma 2.17. When f crosses \mathcal{R}' , by Lemma 2.10 there exists a unique rightmost crossing γ of it; let $V := V_\gamma$ the associated subset of R' given by Lemma 2.9, namely the union of γ with the set of vertices of \mathcal{T} lying to its right (cf. Figure 4). When f does not cross \mathcal{R}' , let $V = R'$. By Lemma 2.11, the region V is explorable from its interior. Besides, for f to cross \mathcal{L} given that it crosses \mathcal{R}' , it is enough for there to be an open path in $(R \cup R') \setminus V$ connecting $\{0\} \times [0, l]$ to γ (which is itself open by definition).

Recall that U_r denotes the set of vertices that are within distance r of the set U . We first assume that V_ℓ stays at distance at least two from the left side of \mathcal{R}' . Define

$$(2.2) \quad \tilde{\partial}V_\ell = \{x \in V_\ell \mid \text{there exists a path in } (R \cup R') \setminus V_\ell \text{ from } \{0\} \times [0, l] \text{ to } x\}.$$

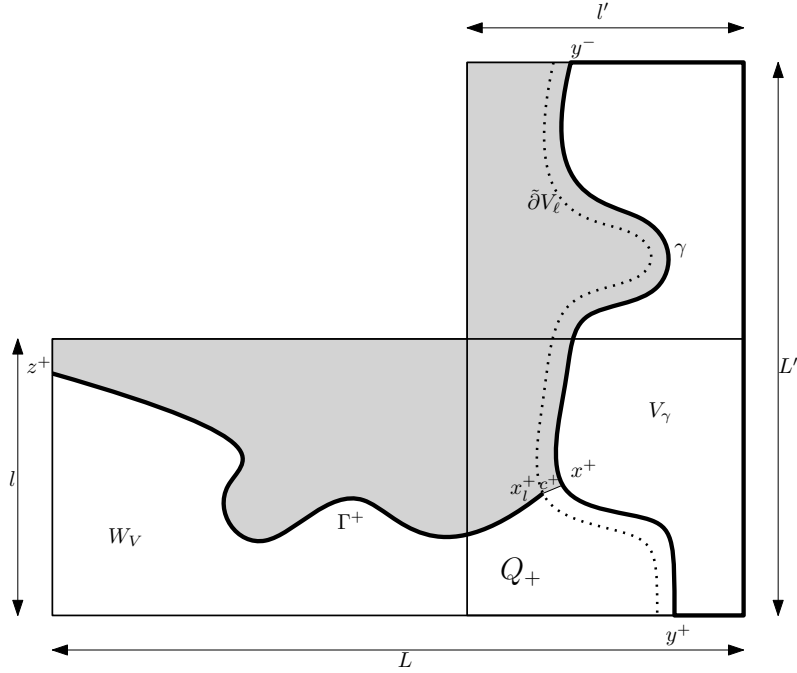

FIGURE 4. Rectangle to L : construction of the quad Q^+ . In the picture, the event $A_{V,r}$ is realized.

Heuristically, this is the left boundary of V_ℓ . Then, $\tilde{\partial}V_\ell$ crosses R' vertically. Indeed, let c be a simple horizontal crossing of R' . First, c crosses $\gamma \subset V_\ell$, so that there exists a first vertex x in $c \cap V_\ell$. Using the boundary of \mathcal{L} , c can be extended to a simple path from the left side of R in $(V_\ell)^c$ since V_ℓ does not touch the left boundary of R' , so that $x \in \tilde{\partial}V_\ell$. Moreover, up to loop-erasure one can assume that $\tilde{\partial}V_\ell$ is a strong crossing. Finally, by the assumption, it can have only one vertex neighbour to the boundary.

By Lemma 2.8 $\tilde{\partial}V_\ell$ defines two quads in $R \cup R'$. Denote by W_V the left one, with left boundary $0 \times [0, l]$ and right boundary $\tilde{\partial}V_\ell$. For $v \subset R'$, denote by $A_{v,\ell}(f)$ the event that $V = v$ and W_V is crossed. Then:

$$(2.3) \quad \mathbf{P}[f \text{ crosses } \mathcal{R}', A_{V,\ell}(f)] = \sum_{v \text{ crossing } R'} \mathbf{P}[V = v, A_{v,\ell}(f)],$$

where the sum is over all possible $v \subset R'$ corresponding to a configuration crossing \mathcal{R}' . For each such v , the events $\{V = v\}$ and $A_{v,\ell}(f)$ are independent, and moreover the probability of $A_{v,r}(f)$ is bounded below by the probability that f crosses \mathcal{R} . So we get

$$(2.4) \quad \mathbf{P}[f \text{ crosses } \mathcal{R}', A_{V,\ell}(f)] \geq \pi(\mathcal{R}) \sum_{v \text{ crossing } R'} \mathbf{P}[V = v] = \pi(\mathcal{R})\pi(\mathcal{R}').$$

Now, when f crosses \mathcal{R}' and $A_{V,\ell}(f)$ is realized, let Γ^+ be the highest horizontal crossing in W_V , and Γ^- the lowest one. The right extremity of Γ^+ (resp. Γ^-) is denoted by $x_\ell^+ \in \Gamma^+ \cap \tilde{\partial}V_\ell$ (resp. $x_\ell^- \in \Gamma^- \cap \tilde{\partial}V_\ell$). Let c^\pm be the shortest path in the lattice between x_ℓ^\pm and V , and denote by x^\pm its extremity in V . Then in fact, $x \in \gamma$, since necessarily x has a neighbour outside V . Note that c^\pm is a strongly simple path, and c^\pm lies in V_ℓ .

Define $z^\pm \in \{0\} \times [0, l]$ the left extremity of Γ^\pm and $y^+ \in [L - l', L] \times \{0\}$ (resp. $y^- \in [L - l', L] \times \{L'\}$) the lower (resp. upper) extremity of γ . Then, the union of the following four disjoint strongly simple paths: c^+ , Γ^+ , $[z^+, 0] \cup [0, y^+]$ and the path (y^+, x^+) in γ between y^+ and x^+ , defines a simple circuit (cf. Figure 4). By loop erasure it is possible

to make this path globally strongly simple. These four paths hence define a quad

$$Q^+ = (c^+, \Gamma^+, [z^+, 0] \cup [0, y^+], (y^+, x^+)) = (V^+, c^+, [z^+, 0] \cup [0, y^+])$$

explorable from its exterior in Λ_L , where V^+ is the geometric support of the quad. Similarly, the paths c^- , the part (x^-, y^-) in γ from x^- to y^- , then the upper left part γ' of $\partial(R \cup R')$ between y^- to z^- , together with Γ^- define another quad

$$Q^- = (c^-, \Gamma^-, \gamma', (x^-, y^-)) = (V^-, c^-, \gamma')$$

explorable from its exterior in Λ_L , where V^- is the support of the quad.

Now, either $Q^+ \in \mathcal{Q}(2\ell, \delta, L)$, or $Q^- \in \mathcal{Q}(2\ell, \delta, L)$, or neither of these two cases happen. We first consider the first case, the second one can be treated similarly. Conditionally on what has been explored, Q^+ is crossed, implying that \mathcal{L} is crossed as well, with conditional probability at least $1 - \beta_f(2\ell, \delta, L)$. The bound is the same in the second case, so by a union bound, and assuming that the third case is impossible, we obtain

$$\pi(\mathcal{L}) \geq \pi(\mathcal{R})\pi(\mathcal{R}') - 2\beta_f(2\ell, \delta, L).$$

We now prove that the third case indeed cannot happen. Suppose the contrary, that is $Q^+ \notin \mathcal{Q}(2\ell, \delta, L)$ and $Q^- \notin \mathcal{Q}(2\ell, \delta, L)$. Then there exists γ^\pm a simple path crossing Q^\pm which does not traverse the annulus $x^\pm + A(2\ell, \delta)$. Since $x^\pm \in R'$ and $\delta < L - l'$, the second extremity of γ^+ (resp. γ^-) lies in $[0, y^+]$ (resp. $\gamma' \setminus \{0\} \times \mathbb{R}$). This implies that c^+ (resp. c^-) is at distance less than $\delta + \ell$ from $\mathbb{R} \times \{0\}$ (resp. $\mathbb{R} \times \{l\}$). In particular, c^+ and c^- are disjoint since $2\delta + 2\ell < l$, and so are γ^+ and γ^- .

Now, x_ℓ^+ is above x_ℓ^- in $\tilde{\partial}V_\ell$ since Γ^+ is above Γ^- . This implies that x^+ is over x^- in γ . Indeed, assuming the inverse, let Q be the quad defined the simple paths (x_ℓ^+, x_ℓ^-) in $\tilde{\partial}V_\ell$, c^- , the path (x^+, x^-) in γ and then c^+ . By Lemma 2.15, c^+ must intersect c^- , which is a contradiction. Then, by exactly the same argument applied to γ^+ and γ^- in the quad V^c , these paths must intersect, which is a contradiction. Hence we can conclude that indeed $Q^+ \in \mathcal{Q}(2\ell, \delta, L)$, or $Q^- \in \mathcal{Q}(2\ell, \delta, L)$, as we claimed.

There only remains to implement a minor modification to the argument in the case when V_ℓ intersects the left boundary of \mathcal{R}' . Since $\ell < L - l'$, consider the last visit x of the boundary of \mathcal{L} by V_ℓ (traversed from top to bottom). The same argument applies, the only modification being that in the definition of W_V , the right boundary must be defined as the portion of V_ℓ below x . \square

In the following Lemma, the parameter k is one of these unpleasant and not fundamental complexities that we have to introduce because of our definition of strong crossing, see Definition 1.5, which implies that only almost squares, and not real squares, are crossed with probability 1/2 (see Lemma 2.13). For a first reading, one can ignore the variable k .

Lemma 2.18 (Rectangle to long rectangle). *Let $\ell > 0$, $\rho \geq 3/4$, $n \in \mathbb{N}^*$ and f have range at most $\ell > 0$. Then, for $n > 8\ell + 24$,*

$$\pi(\mathcal{R}_{(2\rho - \frac{2}{3})n, n}) \geq \frac{1}{4} \pi(\mathcal{R}_{\rho n, n})^2 \pi(\mathcal{R}_{\frac{n}{2}, \frac{n}{2} + 4}) - 4\beta_f(2\ell, \frac{n}{8}, 2\rho n).$$

Proof. The first part of the proof is very similar to the proof of Lemma 2.17. First, by Lemma 2.13, with probability at least $\pi(\mathcal{R}_{\frac{n}{2}, \frac{n}{2} + 4})$ there exists a vertical crossing of the almost square

$$C = [(\rho - \frac{1}{2})n - 4, \rho n] \times [0, \frac{n}{2}]$$

(see Figure 5). For any realization of such a crossing, by Lemma 2.10 we can choose the crossing γ which is the rightmost. The right side in C of γ defines a random explorable set V . Define V' to be the union of V with its symmetric under the reflection of axis $\mathbb{R} \times \{n/2\}$. As before, we can define the "left frontier" $\tilde{\partial}V'_\ell$ of V'_ℓ , see (2.2). Since

$\ell < \rho n - \frac{n}{2} - 4$, $\tilde{\partial}V'_\ell \subset R_{\rho n, n}$, so that it is connected to $\{0\} \times [0, n]$ within $R_{\rho n, n}$ with a conditional probability at least equal to $\pi(\mathcal{R}_{\rho n, n})$.

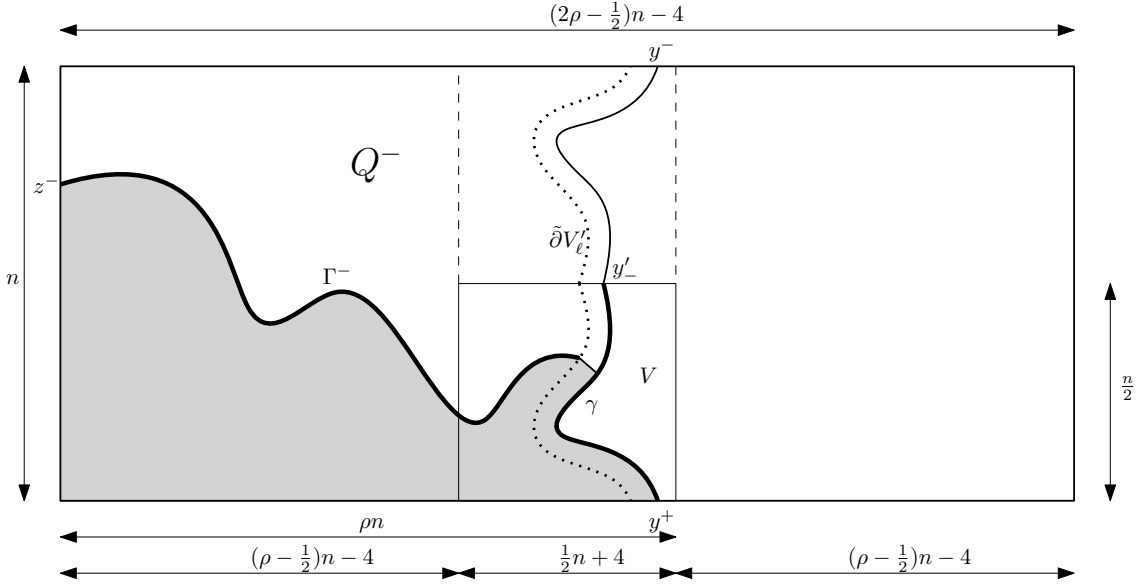

FIGURE 5. Rectangle to long rectangle: first move.

By symmetry, the conditional probability that the lower half $\tilde{\partial}V'_\ell$ of $\tilde{\partial}V_\ell$ is connected to $\{0\} \times [0, n]$ within $\mathcal{R}_{\rho n, n} \setminus V_\ell$ is at least $\pi(\mathcal{R}_{\rho n, n})/2$ (this is the event pictured in Figure 5). The proof is now very close to the one of the previous lemma. The left connected component W_L of $R_{\rho n, n} \setminus \tilde{\partial}V'_\ell$ is the support of a quad

$$Q = (W_L, \{0\} \times [0, n], \tilde{\partial}V_\ell).$$

Let Γ^- (resp. Γ^+) be the lowest (resp. highest) such horizontal crossing reaching V_ℓ at a point $x_\ell^- \in \tilde{\partial}V_\ell$ (resp. $x_\ell^+ \in \tilde{\partial}V_\ell$), c^\pm be the shortest path in \mathcal{T} from x_ℓ^\pm to γ (hence in V), $x^\pm \in V$ be the second extremity of c^\pm , $y^+ \in [(\rho - 1/2)n - 4, \rho n] \times \{0\}$ be the lowest point of γ , $y_- \in [(\rho - 1/2)n - 4, \rho n] \times \{n\}$ the highest point of γ' (the symmetric of γ) and y'_- be the last intersection of γ with $\{n/2\} \times \mathbb{R}$. Let $z_\pm \in \{0\} \times [0, n]$ be the left extremity of Γ_\pm . For any pair of points $(x, y) \in \gamma^2$, denote by $[x, y]_\gamma$ the path in γ between x and y , and define

$$[z^-, y'_-]_\partial := [z^-, (0, n)] \cup [(0, n), y^-] \cup [y^-, y'_-]_\gamma.$$

Then, the four simple paths c^- , Γ^- , $[z^-, y'_-]_\partial$ and $[y'_-, x^-]_\gamma$ define the quad

$$Q^- = (V_-, c^-, [z^-, y'_-]_\partial).$$

Similarly, c^+ , Γ^+ , $[z^+, 0] \cup [0, y^+]$ and $[y^+, x^+]_\gamma$ define the quad

$$Q^+ = (V_+, c^+, [z^+, 0] \cup [0, y^+]).$$

As in the proof of Lemma 2.17, we can prove that either $Q^- \in \mathcal{Q}(2\ell, n/8, \rho n)$, or $Q^+ \in \mathcal{Q}(2\ell, n/8, \rho n)$. If not, then c^+ (resp. c^-) is at distance less than $2(n/8) + 2\ell < n/2$ from $\mathbb{R} \times \{0\}$ (resp. $\mathbb{R} \times \{n/2\}$), so that c^+ is disjoint from c^- , which implies a topological contradiction by Lemma 2.15.

Consequently, whenever the two crossings γ and Γ^\pm exist, they are glued with conditional probability at least $1 - 2\beta_f(2\ell, n/8, \rho n)$. The situation where $V_\ell \not\subset [0, (\rho - 1/2)n] \times \mathbb{R}$ is handled similarly as in the proof of Lemma 2.17.

To sum up the first step of the argument: with probability at least

$$\frac{1}{2}\pi(\mathcal{R}_{\rho n, n})\pi(\mathcal{R}_{n/2, n/2+4}) - 2\beta_f(2\ell, n/8, \rho n),$$

we get $v_{k+1} \geq v_k^2 - \max_{0 \leq j \leq k} b_j$ with $0 < v_0 < 1$. Since β_f is non decreasing in its third variable, by a simple induction, this implies that

$$\forall k \geq 1, v_k \geq v_0^{2^k} - 4^k \sqrt{b_{k-1}}$$

as long as the right-hand term remains positive — and of course afterwards as well because we know that $v_k \geq 0$. Replacing v_k by its definition, and using $2^k = 12\rho_k - 8$, we get

$$\pi(\mathcal{R}_{\rho_k n, n}) \geq \frac{4^9}{m_n^{17}} (m_n^2/4)^{12\rho_k} - 4(12\rho_k - 8)^2 (\beta_f(2\ell, n/8, 2\rho_{k-1}n)/m_n)^{1/2}.$$

Now for any $\rho \geq 3/4$, choose k so that ρ_k is the first above ρ : in particular $\rho_{k-1} \leq \rho$, and by monotonicity of $\pi(\mathcal{R}_{\rho n, n})$ in ρ ,

$$\pi(\mathcal{R}_{\rho n, n}) \geq \frac{4^9}{m_n^{17}} (m_n^2/4)^{24\rho} - 4(24\rho - 8)^2 (\beta_f(2\ell, n/8, 2\rho n)/m_n)^{1/2},$$

which implies the Lemma. \square

Remark 2.20. Lemma 2.19 is stated in the general setup of finite-range models; in the case of a self-dual model (such as when f is the sign of a symmetric Gaussian field with finite-range covariance), as we mentioned before one has identically $\pi(\mathcal{R}_{3/4n, n}) \geq 1/2$ and $\pi(\mathcal{R}_{n/2, n/2+4}) \geq 1/2$, so $m_n \geq 1/2$ and the bound becomes

$$\pi(\mathcal{R}_{\rho n, n}) \geq 2^{-96\rho+35} - 4000\rho^2 \beta_f(2\ell, n/8, 2\rho n)^{1/2}.$$

Lemma 2.21 (Long Rectangle to Annulus). *Let $\ell > 0$, $n \in \mathbb{N}^*$, f have range at most $\ell > 0$, and $\psi(n)$ be the probability that the annulus $\mathcal{A}(n, 2n)$ contains an f -circuit. Then, whenever $n > 8\ell$,*

$$\psi(n) \geq \pi(\mathcal{R}_{4n, n})^4 - 8\beta\left(2\ell, \frac{n}{4}, 4n\right).$$

Proof. The proof follows the same lines as for the previous lemmas. First, by Lemma 2.17, since $2\ell < \min(\frac{n}{4}, \frac{3n}{2})$, with probability at least

$$\pi(\mathcal{R}_{4n, n})^2 - 2\beta_f(2\ell, \frac{n}{4}, 4n),$$

there exists a crossing from $[-2n, -n] \times \{-2n\}$ to $\{2n\} \times [n, 2n]$ in the quad Q composed of the union the horizontal $R_+ := [-2n, 2n] \times [n, 2n]$ and the vertical rectangle $R := [-2n, -n] \times [-2n, 2n]$. Then, by an immediate generalization of the same Lemma 2.17, with probability at least

$$\pi(\mathcal{R}_{4n, n})^3 - 4\beta_f(2\ell, \frac{n}{4}, 4n),$$

there exists a crossing of the U-shaped quad $U' = U \cup R_-$, where $R_- := [-2n, 2n] \times [-2n, -n]$, from $\{2n\} \times [-2n, -n]$ to $\{2n\} \times [n, 2n]$. Cf. Figure 7.

Let Γ be the outermost such crossing and denote by $\tilde{\partial}V_\ell$ the "inner boundary" of V_ℓ , where V denotes the quad "outside" Γ in U' . As in Lemma 2.17, erasing loops allows us to assume that $\tilde{\partial}V_\ell$ is a strongly simple. We assume first that it stays within U' , so that it is a crossing of the quad. Let x_ℓ^- be the highest intersection of $\tilde{\partial}V_\ell$ with the vertical segment $\{-n\} \times [-2n, -n]$ and by x_ℓ^+ the lowest intersection of $\tilde{\partial}V_\ell$ with the vertical segment $\{-n\} \times [n, 2n]$. We define a new quad Q by the following four simple paths:

- the first one γ_1 is the union of the vertical segment S^- between x_ℓ^- and $(-n, -n)$ with $[-n, n] \times \{-n\} \cup \{n\} \times [-n, n] \cup [-n, n] \times \{n\}$, and with S^+ the vertical segment between $(-n, n)$ and x_ℓ^+ ;
- The second one is the section v_ℓ^+ of $\tilde{\partial}V_\ell$ between x_ℓ^+ and z_ℓ^+ , where z_ℓ^+ (resp. z_ℓ^-) is the upper (resp. lower) right extremity of $\tilde{\partial}V_\ell$;
- The third one is $[z_\ell^+, z_\ell^-]$;
- The last one is v_ℓ^- the section of $\tilde{\partial}V_\ell$ between z_ℓ^- and x_ℓ^- .

The quad Q is defined by $Q := (W, v_\ell^+, v_\ell^-)$, where W is the support of Q . Since S^+ and S^- are disjoint, Lemma 2.15 implies that the order on ∂Q is $(z_\ell^-, x_\ell^-, x_\ell^+, z_\ell^+)$.

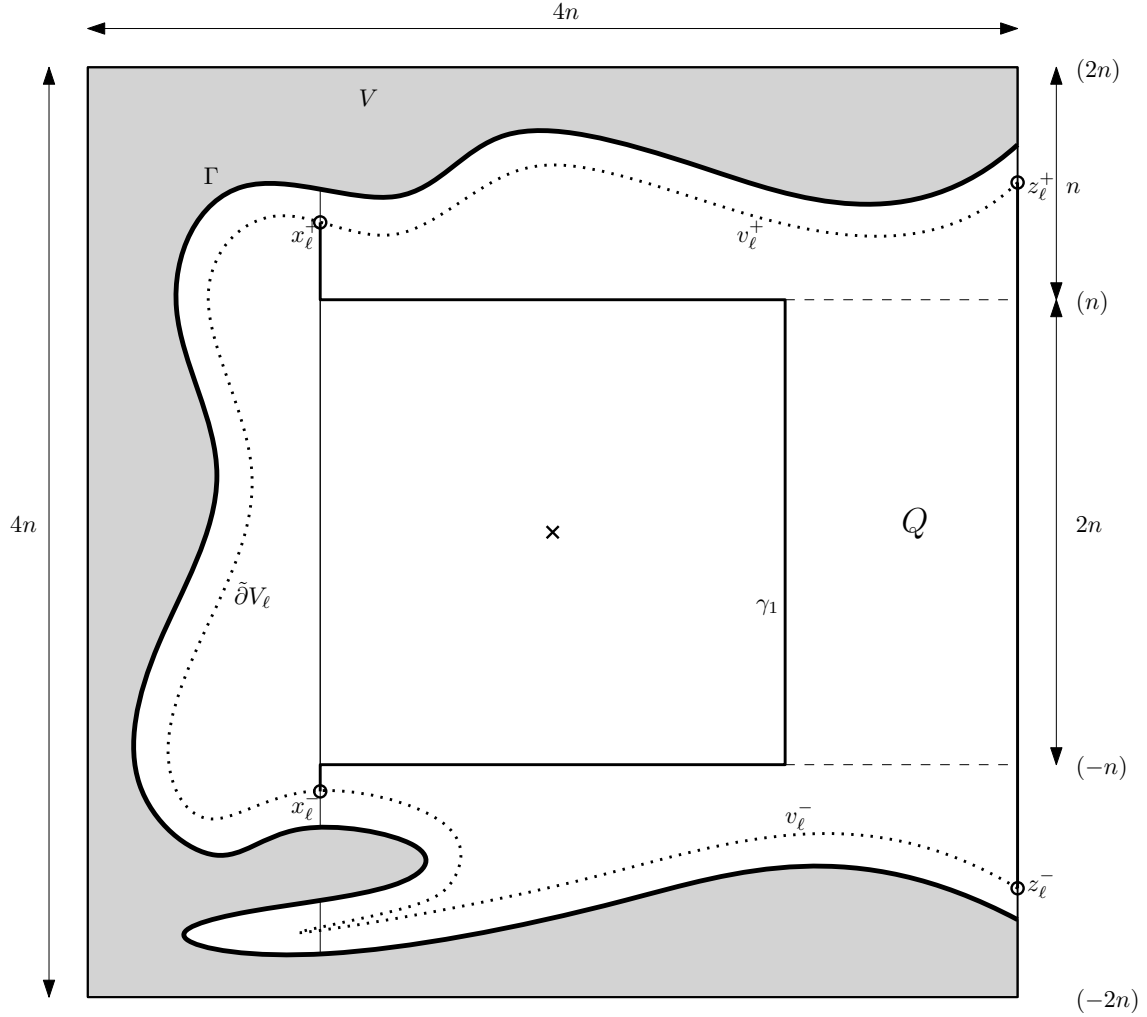

FIGURE 7. Long rectangle to annulus: construction of the quad Q (the circles denote the corners of Q).

Now, with probability at least $\pi(\mathcal{R}_{4n,n})$ there is a crossing of Q . Very similarly as in the proof of Lemma 2.17, choosing Γ' either the innermost or the outermost such crossing of Q allows to glue Γ' to the upper part of Γ with probability at least $1 - 2\beta_f(2\ell, \frac{n}{4}, 4n)$. Now conditioning on such a crossing, we can again extend it up to the boundary with a conditional probability at least $1 - 2\beta_f(2\ell, \frac{n}{4}, 4n)$. The result follows from a union bound and the fact that β_f is non-increasing with the second variable. \square

We summarize the estimates we obtained so far as a take-home lower bound, the proof of which is a direct concatenation of the previous lemmas:

Proposition 2.22 (Square to annulus). *Let $n \in \mathbb{N}^*$, and f have range at most $\ell > 0$. Then, whenever $8\ell < n$,*

$$\psi(n) \geq \frac{m_n^{700}}{2^{696}} - 9\beta_f(2\ell, \frac{n}{8}, 8n)^{1/2}.$$

If f is a self-dual model, this gives

$$(2.5) \quad \psi(n) \geq 2^{-1396} - 9\beta_f(2\ell, \frac{n}{8}, 8n)^{1/2}.$$

Proof. Just putting the estimates from the previous lemmas together gives

$$\psi(n) \geq \left[\frac{m_n^{175}}{2^{174}} - 2^{16} \left(\frac{\beta_f(2\ell, n/8, 8n)}{m_n} \right)^{1/2} \right]^4 - 8\beta_f(2\ell, n/4, 4n).$$

Expanding, keeping only the negative corrections, we get the crude lower bound:

$$\begin{aligned} \psi(n) &\geq \frac{m_n^{700}}{2^{696}} - \frac{m_n^{525}}{2^{522}} 2^{16} \beta_f(2\ell, n/8, 8n)^{1/2} - m_n^{175} 2^{48-174} \beta_f(2\ell, n/8, 8n)^{3/2} \\ &\quad - 8\beta_f(2\ell, n/8, 8n) \\ &\geq \frac{m_n^{700}}{2^{696}} - 9\beta_f(2\ell, n/8, 8n)^{1/2}. \end{aligned}$$

□

Here and above, we were nowhere careful to get optimal bounds, and rather focused on obtaining explicit constants so that the dependency on the model is made apparent. Notice in particular that the value 2^{-1396} is completely universal (given self-duality).

Being able to construct open circuits in annuli now allows us to construct crossings of more general quads than just rectangles:

Lemma 2.23 (Gluing quads). *Let $n \in \mathbb{N}^*$, $n \geq 2$, $L > 3n$, $0 < \ell < \ell_1$, f have range at most ℓ , $Q \in \mathcal{Q}_{n,3n,L}$ be a quad explored from its outside. Then, whenever $2\ell_1 < n$,*

$$P[Q \text{ is glued}] \geq \psi(n) - 2\beta_f(\ell_1, n - \ell_1, L) - 2\beta_f(\ell, \ell_1, L).$$

Proof. Let $x' \in \Lambda_L$ and the sub-quad $Q' = (U', \gamma, \gamma')$ be given by Lemma 2.14 associated to Q , that is a quad whose geometric support U' lies inside that of Q , with inner and outer sides in the two components of $x' + \partial A(n, 3n)$ and the other two sides γ_1 and γ_2 included in those of Q . We write $(Q')^* = (U', \gamma_1, \gamma_2)$.

First, assume that there is an ℓ_1 -squeezing of the quad Q' inside the annulus $A := x' + A(n, 3n)$, that is the distance between γ_2 and γ_1 inside A is less than ℓ_1 (see Figure 8). Let γ'' the geodesic between the two closest points. Then, since γ'' is at least at distance $n - \ell_1$ from one of the two components of ∂A , one can construct a sub-quad $U'' \in \mathcal{Q}(\ell_1, n - \ell_1, L)$ so that it can be glued (and consequently, U as well) with probability at least

$$1 - \beta_f(\ell_1, n - \ell_1, L).$$

On the other hand, assume now that there is no squeezing of the quad Q' in $A(n, 3n)$ (see Figure 9). Then, since $Q' \in \mathcal{Q}(n, 3n, L) \subset \mathcal{Q}(n, 3n - 2\ell_1, L)$, let $x'' \in \Lambda_L$ and the quad Q'' be given by Lemma 2.14 associated to Q' , that is a quad with sides in $x'' + \partial A(n, 3n - 2\ell_1)$ and complementary sides included in the ones of Q' , hence in Q . We write $(Q'')^* = (U'', \gamma^+, \gamma^-)$. Define

$$U''_\ell := U'' \cap (\Lambda_L \setminus Q)_\ell.$$

Conditionally on the field f outside U , the field within U''_ℓ still has the same distribution as f , and it can be coupled with a realization \tilde{f} of the field in the whole plane in such a way that f and \tilde{f} coincide within U''_ℓ . Let

$$\gamma''_\ell^\pm = \{x \in U''_\ell, \text{dist}(x, \gamma^\pm) \leq \ell, \exists \text{ a path from } x \text{ to } \gamma^\mp \text{ in } U''\}.$$

Heuristically, γ''_ℓ^\pm is the ℓ -neighborhood of γ^\pm inside Q'' .

Let E be the event that \tilde{f} contains a circuit surrounding the annulus. By definition, since $3n - 2\ell_1 \geq 2n$, $\mathbf{P}[E] \geq \psi(n)$. On the other hand, on the event E , U'' is almost crossed, in the sense that U''_ℓ is crossed; the associated crossing paths all have diameter at least ℓ_1 . As in Lemma 2.17, define Γ^- to be the lowest crossing in U''_ℓ . It meets γ''_ℓ^- at a point x''_ℓ^- . Let c^- be the shortest path in U' from x''_ℓ^- to γ^- , and x^- the other extremity of γ^- . Now four simple paths c^- , the upper part of γ^- between x^- and $C(0, R)$, $C(0, R) \cap \partial U'$

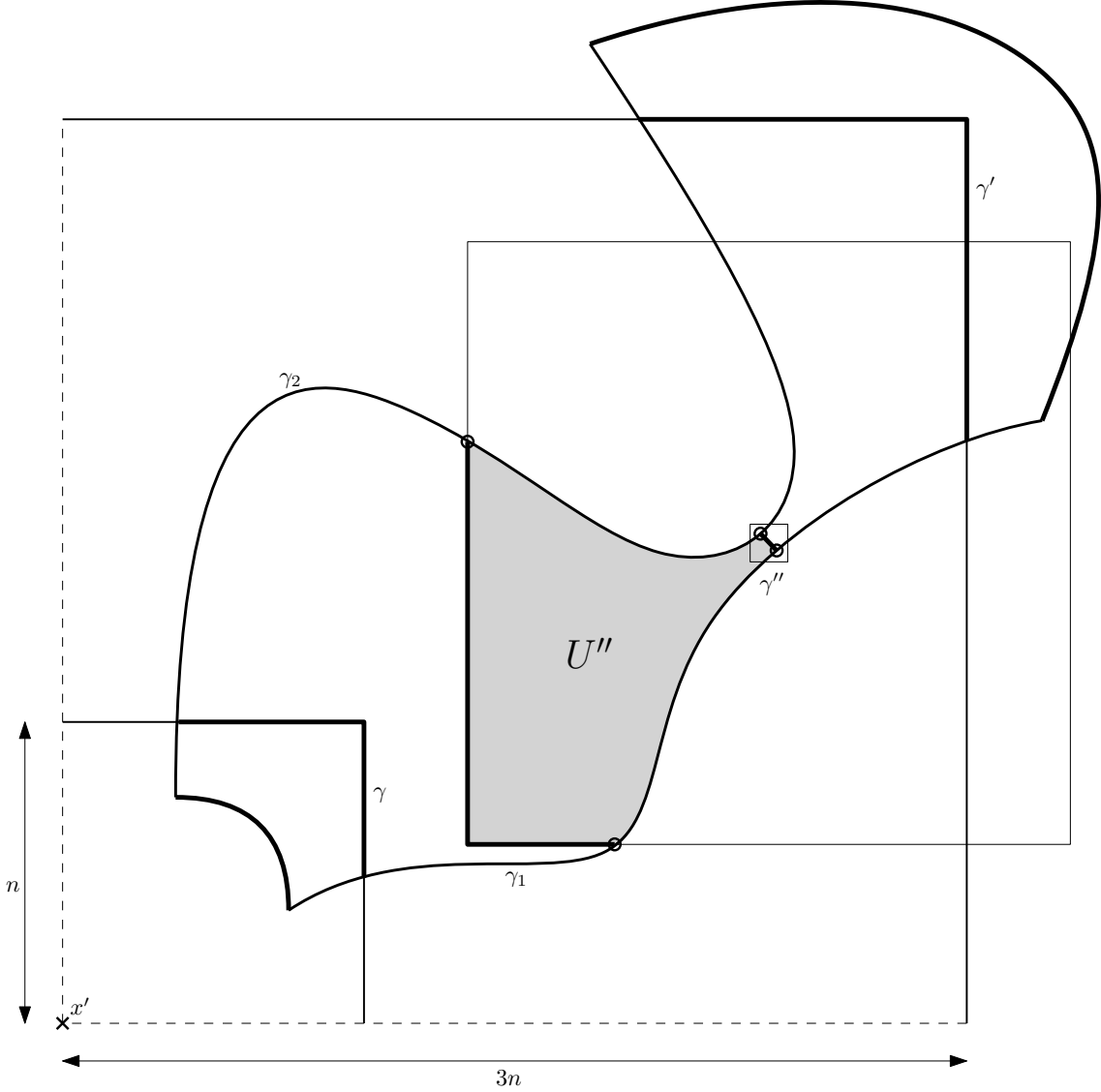
FIGURE 8. Gluing quads: construction of U'' in the squeezing case.

union the part of γ_ℓ^+ between $C(0, R)$, the left extremity of Γ^- (in this order) define a quad Q^- explorable from its exterior, cf. Figure 9. By construction, this quad lies inside $\mathcal{Q}(\ell, \ell_1, L)$, so that with probability $1 - \beta_f(\ell, \ell_1, L)$, there is a positive crossing from Γ^- in U'' to γ^+ , or a positive crossing from Γ^+ to γ^+ .

Then, let us choose Γ'_- the most innermost crossing between γ_ℓ^+ and γ^- and glue similarly Γ'_- to γ^+ with probability at least $1 - \beta_f(\ell, \ell_1, L)$. The lemma follows by a direct union bound. \square

Lemma 2.24 (Long quad). *Let $0 < \ell < \ell_1 < r < R < L < L'$ such that $8\ell + 24 < \ell_1$, f have range at most ℓ , $Q \in (r, R, L, L')$ be a random quad explorable from its exterior, and let $m := \min\{m_n : n \geq \ell\}$. Then*

$$\mathbf{P}[Q \text{ is glued}] \geq 1 - (8r/R)^c$$

where the exponent is given by

$$c = \left(\frac{m^{700}}{2^{696}} - 9\beta_f(2\ell, r/2, L)^{1/2} - 2\beta_f(\ell, \ell_1, L) - 2\beta_f(\ell_1, 4r - \ell_1, L) \right)_+.$$

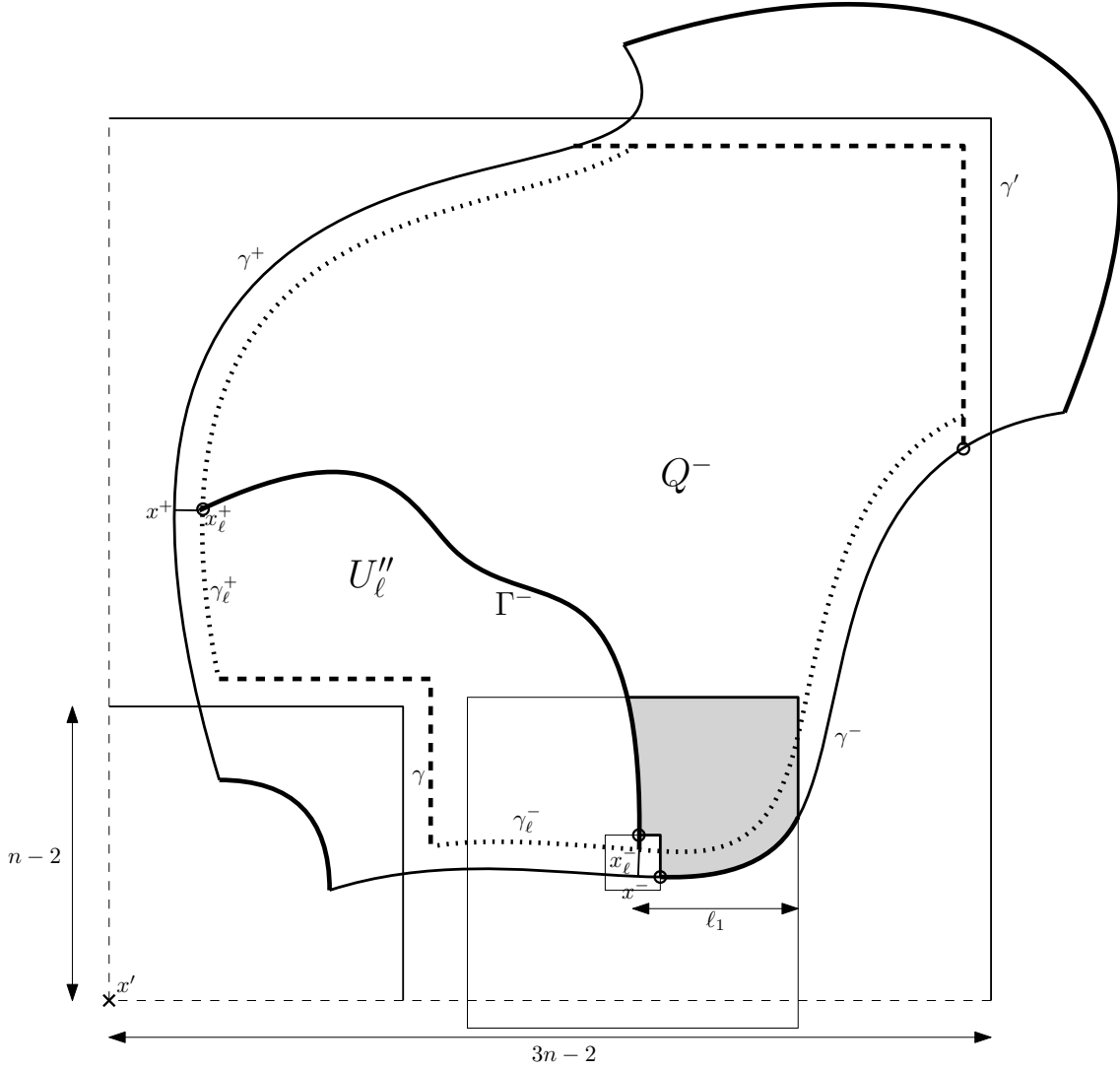
FIGURE 9. Gluing quads: construction of Q^- in the non-squeezing case.

Proof. For any $k \in \mathbb{N}^*$, let $n_k := 4^k r$, and let E_k denote the event that Q is glued inside $A(n_k, 3n_k)$. Notice that since $r > \ell$, for every $k \geq 1$ one has $n_k > 3n_{k-1} + \ell$, so that the events $(E_k)_{k \geq 1}$ are independent. Last, let $K := \max\{k : 2n_k < R\}$. Then by Lemma 2.23,

$$\mathbf{P}[Q \text{ is not glued}] \leq \prod_{k=1}^K (1 - \psi(n_k) + 2\beta_f(\ell, \ell_1, L) + 2\beta_f(\ell_1, n_k - \ell_1, L)).$$

The function β_f is non-increasing in its second variable and non-decreasing in its third variable, so that by Proposition 2.22 (using $8\ell + 8 < 2r$)

$$\begin{aligned} \mathbf{P}[Q \text{ is not glued}] &\leq \left(1 - \frac{m^{700}}{2^{696}} + 9\beta_f(2\ell, r/2, L)^{1/2} \right. \\ &\quad \left. + 2\beta_f(\ell, \ell_1, L) + 2\beta_f(\ell_1, 4r - \ell_1, R) \right)^K. \end{aligned}$$

Noticing that $K \geq \frac{\log[R/(8r)]}{\log 4}$ leads to $\mathbf{P}[Q \text{ is not glued}] \leq (8r/R)^\alpha$ with

$$\alpha = \frac{-1}{\log 4} \log \left(1 - \frac{m^{700}}{2^{696}} + 9\beta_f(2\ell, r/2, L)^{1/2} + 2\beta_f(\ell, \ell_1, L) + 2\beta_f(\ell_1, 4r - \ell_1, L) \right).$$

Using $-\log(1-u) \geq u$ and $1 < \log 4 < 2$ gives the bound under the assumption that $8r < R$; it is vacuous otherwise, thus completing the proof. \square

Proof of Theorem 2.16. The first assertion of Theorem 2.16 is a direct consequence of Lemma 2.24, using the finite range of f to obtain uniformity in the third variable of β_f . This implies that f is well behaved. Indeed, let $2\ell_2 < L \leq L'$ and $r \leq 2\ell_2 \leq R \leq L$. Then,

$$\begin{aligned} \beta_f(r, R, L, L') &\leq \beta_f(2\ell_2, R, L, L') \\ &\leq (16\ell_2/R)^{2^{-1297}} \\ &\leq 2(\ell_2)^{2^{-1297}} (r/R)^{2^{-1297}}. \end{aligned}$$

On the other hand, for $1 \leq r \leq R \leq 2\ell_2$,

$$\beta_f(r, R, L, L') \leq 1 \leq (2\ell_2)^{2^{-1297}} (r/R)^{2^{-1297}}.$$

Now, fix $\rho \geq 1$. By Lemma 2.19 and the fact that f is well behaved, there exists a (universal) $c > 0$ such that for any n large enough, $\pi(\mathcal{R}_{\rho n, n}) > c$. Similarly, by Lemma 2.21, f surrounds with uniform probability the annuli $\mathcal{A}(n, 2n)$. This implies that f satisfies the BXP and the annulus condition for the SBXP.

The proof of the quad condition of the SBXP follows the standard lines, again replacing applications of the FKG inequality with our gluing technology as we have done a few times already. More specifically: fix a quad Q , and let $(R_k)_{k \leq K}$ be a finite sequence of rectangles of aspect ratio 3 (say), alternatively horizontal and vertical, such that crossing all of them implies crossing the quad. By a very similar argument as in the proof of Lemma 2.24 and using a direct generalization of Lemma 2.17, we obtain a lower bound for the probability of crossing nQ that strongly depends on K , but is uniform in n large enough. \square

2.5. General models. From now on, f will be a symmetric random sign function on the lattice \mathcal{T} , with no assumption of finite range. We keep the notation $\beta_f(r, R, L, L')$ and $\text{WB}_f(\lambda, L, L')$ of Definition 2.3, and start with a statement of automatic uniformity in L' of the good behavior condition (the corresponding statement for a finite-range model was mentioned in the beginning of the previous subsection, and was much simpler):

Lemma 2.25. *Let $C > 0$ and $\beta > \alpha > 0$, and fix $c > 1$: then, for every $\lambda > 0$ there exists $\lambda' > 0$ such that, for every well decorrelated sign function f (with constants C, α, β) and every $n \geq 2$,*

$$\text{WB}_f(\lambda, n, n^c) \implies \text{WB}_f(\lambda', n).$$

Moreover, the same implication holds for any $\lambda' > \max(\lambda + 2^{1+\alpha}C, \frac{1}{(\beta-\alpha)^c}, C)$ provided n is chosen large enough.

Proof. Fix for a moment $1 \leq r \leq R \leq L < L' \leq L''$ and set $\ell \leq L' - L$. By definition, f can be coupled with an ℓ -dependent sign function g in such a way that they agree within the box $\Lambda_{L''+\ell}$ with probability at least $1 - \theta_f(2L'', \ell)$. In particular:

$$\begin{aligned} |\beta_f(r, R, L, L') - \beta_g(r, R, L, L')| &\leq \theta_f(2L'', \ell), \\ |\beta_f(r, R, L, L'') - \beta_g(r, R, L, L'')| &\leq \theta_f(2L'', \ell). \end{aligned}$$

On the other hand, because both L' and L'' are greater than $L + \ell$, we have the equality $\beta_g(r, R, L, L') = \beta_g(r, R, L, L'')$ and it follows that

$$(2.6) \quad 0 \leq \beta_f(r, R, L, L'') - \beta_f(r, R, L, L') \leq 2\theta_f(2L'', \ell).$$

Now, let $0 < v < c(\beta - \alpha)/\alpha$. Applying (2.6) repeatedly along a geometric sequence $L'_k = n^{c+kv}$, taking at each scale $\ell_k = (1 - n^{1-c})L'_k \leq L'_k - n$, we get

$$\begin{aligned} \beta_f(r, R, n) - \beta_f(r, R, n, n^c) &= \sum_{k=0}^{\infty} \left[\beta_f(r, R, n, n^{c+(k+1)v}) - \beta_f(r, R, n, n^{c+kv}) \right] \\ &\leq \sum_{k=0}^{\infty} 2\theta_f \left(2n^{c+(k+1)v}, (1 - n^{1-c})n^{c+kv} \right). \end{aligned}$$

So far we have not used any hypothesis on f . Using the fact that it is well decorrelated, we obtain

$$\begin{aligned} \beta_f(r, R, n) - \beta_f(r, R, n, n^c) &\leq \sum_{k=0}^{\infty} 2C(2n^{c+(k+1)v})^\alpha ((1 - n^{1-c})n^{c+kv})^{-\beta} \\ &= \frac{2^{1+\alpha} C n^{(c+v)\alpha - c\beta}}{(1 - n^{1-c})^\beta} \sum_{k=0}^{\infty} n^{-kv(\beta - \alpha)} \\ &= \frac{2^{1+\alpha} C}{(1 - n^{1-c})^\beta (1 - n^{-v(\beta - \alpha)})} n^{(c+v)\alpha - c\beta}. \end{aligned}$$

If in addition $\text{WB}_f(\lambda, n, n^c)$ holds, using $r/R > 1/n$ we obtain

$$(2.7) \quad \beta_f(r, R, n) \leq \lambda(r/R)^{1/\lambda} + \frac{2^{1+\alpha} C}{(1 - n^{1-c})^\beta (1 - n^{-v(\beta - \alpha)})} (r/R)^{c\beta - (c+v)\alpha}.$$

This already gives the first conclusion. To get the second, notice that one can choose v arbitrarily small in the above argument, and that the multiplicative prefactor in the second term of (2.7) converges to $2^{1+\alpha} C$ as $n \rightarrow \infty$. \square

Lemma 2.26. Fix $C > 0$ and $\beta > 2\alpha > 0$, and define

$$\eta := \frac{1}{3} \left(1 - \left(\frac{2\alpha}{\beta} \right)^{1/3} \right), \quad c := \frac{1}{(1 + \eta)(1 - 2\eta)^2}, \quad \varepsilon := \frac{1}{2} - \eta,$$

$$\nu := \varepsilon\beta - \alpha c(1 + \eta), \quad \lambda^* := \max \left(4C, \frac{4(1 + \eta)}{\nu}, 2^{1398} \right),$$

$$\text{and } N = N(\lambda, \varepsilon, \eta) := (16^{1402} \lambda^4)^{\frac{\lambda}{1 - 2\varepsilon - \eta}},$$

so that in particular $\eta > 0$, $c > 1 + \eta$, $2\varepsilon + \eta < 1$, $\nu > 0$ and $N < \infty$. Whenever f is a self-dual, well decorrelated field (with constants C , α , β),

$$\forall \lambda \geq \lambda^*, \forall n \geq N, \quad \text{WB}_f(\lambda, n, n^c) \implies \text{WB}_f(\lambda + 2Cn^{-3/\lambda}, n^{1+\eta}, n^{(1+\eta)c}).$$

Proof. Let f be a well decorrelated coloring with constants C , α , β , and fix $\lambda \geq \lambda^*$ and $n \geq N$. By definition, there exists a random coloring g with range at most n^ε and a coupling of f and g such that they agree on $\Lambda_{n^{c(1+\eta)}}$ outside an event of probability at most

$$\theta_f(n^\varepsilon, n^{c(1+\eta)}) \leq Cn^{-\nu}.$$

Then for any $r \leq R \leq n^{1+\eta}$,

$$(2.8) \quad |\beta_f(r, R, n, n^c) - \beta_g(r, R, n, n^c)| \leq Cn^{-\nu},$$

$$(2.9) \quad |\beta_f(r, R, n^{1+\eta}, n^{(1+\eta)c}) - \beta_g(r, R, n^{1+\eta}, n^{(1+\eta)c})| \leq Cn^{-\nu}.$$

Assume now that the condition $\text{WB}_f(\lambda, n, n^c)$ is satisfied: for all $r \leq R \leq n$, we get the upper bound

$$(2.10) \quad \beta_f(r, R, n, n^c) \leq \lambda(r/R)^{1/\lambda} + Cn^{-\nu} \leq 2\lambda(r/R)^{1/\lambda},$$

so we can apply Theorem 2.16 to the random coloring g . Choosing $\ell = n^\varepsilon$,

$$\ell_1 = 2(2^{1402}\lambda)^\lambda \ell \quad \text{and} \quad \ell_2 = (2^{1402}\lambda)^\lambda \ell_1 = 2(2^{1402}\lambda)^{2\lambda} \ell,$$

we can check the assumptions of the theorem, namely

$$\beta_g(2\ell, \ell_1, n, n^c) \leq 2\lambda(2\ell/\ell_1)^{1/\lambda} = 2^{-1402}$$

and the same bound for $\beta_g(\ell_1, \ell_2, n, n^c)$; therefore,

$$\forall 2\ell_2 < r < R < n^{1+\eta} \quad \beta_g(r, R, n^{1+\eta}, n^{(1+\eta)c}) \leq (8r/R)^{2^{-1397}}$$

which, by (2.9), implies over the same range of r and R the bound

$$\begin{aligned} \beta_f(r, R, n^{1+\eta}, n^{(1+\eta)c}) &\leq (8r/R)^{2^{-1397}} + Cn^{-\nu} \\ &\leq (8r/R)^{2^{-1397}} + C(r/R)^{\nu/(1+\eta)}. \\ &\leq (8r/R)^{2^{-1397}} + \frac{\lambda}{4}(r/R)^{4/\lambda} \leq \frac{\lambda}{2}(r/R)^{2/\lambda}. \end{aligned}$$

It remains to consider the cases where $r < 2\ell_2$. If $R > n$, monotonicity of β_f in its first variable gives, using $R/r \leq n^{1+\eta}$ in the last line:

$$\begin{aligned} \beta_f(r, R, n^{(1+\eta)}, n^{c(1+\eta)}) &\leq \beta_f(2\ell_2, n, n^{1+\eta}, n^{c(1+\eta)}) \leq \frac{\lambda}{2}(2\ell_2/n)^{2/\lambda} \\ &\leq \frac{\lambda}{2}4^{2/\lambda}(2^{1402}\lambda)^4 n^{2(\varepsilon-1)/\lambda} \\ &\leq \lambda(2^{1402}\lambda)^4 n^{(2\varepsilon+\eta-1)/\lambda} (r/R)^{1/\lambda} \leq \lambda(r/R)^{1/\lambda} \end{aligned}$$

because $n \geq N(\lambda, \varepsilon, \eta)$. Last, if $R < n$, we can apply the bound (2.9) above to obtain

$$\begin{aligned} \beta_f(r, R, n^{1+\eta}, n^{c(1+\eta)}) &\leq \lambda(r/R)^{1/\lambda} + 2Cn^{-\nu} \\ &\leq \lambda(r/R)^{1/\lambda} + 2Cn^{-4/\lambda} \\ &\leq \left(\lambda + 2Cn^{-3/\lambda}\right) (r/R)^{1/\lambda}. \quad \square \end{aligned}$$

Proof of Theorem 2.7. Let f be a well decorrelated coloring with constants C , α , β , and fix $\lambda \geq \lambda^*$ and $n \geq N$. We intend to apply Lemma 2.26 repeatedly, which leads us to define the sequences (λ_k) and (n_k) inductively by letting $n_0 = n$, $\lambda_0 = \lambda$ and for all $k \geq 0$,

$$n_{k+1} = n_k^{1+\eta} \quad \text{and} \quad \lambda_{k+1} = \lambda_k + 2Cn_k^{-3/\lambda_k}.$$

We first show by induction that for every $k \geq 0$, $\lambda_k \leq 3\lambda$: indeed, assuming this holds up to index k , we have

$$\begin{aligned} \lambda_{k+1} &\leq \lambda_0 + 2C \sum_{i=0}^k n_i^{-1/\lambda} = \lambda + 2C \sum_{i=0}^k n^{-(1+\eta)^i/\lambda} \\ &\leq \lambda + 2C \sum_{i=0}^k n^{-(1+i\eta)/\lambda} \leq \lambda + \frac{2C}{1 - n^{-\eta/\lambda}} \leq 3\lambda \end{aligned}$$

where the last step follows from the bounds $\lambda \geq \lambda^* \geq 4C$ and $n \geq \bar{N} \geq (4/3)^{\lambda/\eta}$.

Now, assume that $\text{WB}_f(\lambda, n, n^c)$ holds. We always have $3\lambda \geq \lambda_k \geq \lambda^*$ and $n_k \geq n$, therefore in particular $n_k \geq N(\lambda_k, \varepsilon, \eta)$ and we can indeed apply Lemma 2.26 inductively, to obtain that

$$\forall k \geq 0, \quad \text{WB}_f(\lambda_k, n_k, n_k^c) \text{ holds.}$$

By monotonicity, it is hence true that $\text{WB}_f(3\lambda, n_k, n_k^c)$ holds as well for all $k \geq 0$. By Lemma 2.25, there exists $\bar{\lambda} > 0$ (depending only on λ , C , α and β) such that

$$\forall k \geq 0, \quad \text{WB}_f(\bar{\lambda}, n_k) \text{ holds,}$$

which concludes the argument. \square

Proof of Proposition 1.10. Fix $\lambda > 0$, such that f is λ -well behaved. We first show the BXP. Fix $\rho \geq 1$ and $n > 0$. By definition there exists g with range at most $n^{1/2}$, and a coupling of f with g , such that they coincide in $\Lambda_{3\rho n}$ with probability at least $1 - C_\rho n^{\alpha-\beta/2}$. In particular

$$\begin{aligned} \beta_g(2n^{1/2}, n/8, 2\rho n, 3\rho n) &\leq \beta_f(2n^{1/2}, n/8, 2\rho n, 3\rho n) + C_\rho n^{\alpha-\beta/2} \\ &\leq \lambda(16n^{-1/2})^{1/\lambda} + C_\rho n^{\alpha-\beta/2}. \end{aligned}$$

By Lemma 2.19,

$$\pi(\mathcal{R}_{\rho n, n}) \geq 2^{-96\rho+35} - 4000\rho^2 \beta_g(2n^{1/2}, n/8, 2\rho n, 3\rho n)^{1/2} - C_\rho n^{\alpha-\beta/2}.$$

Combining these two bounds proves the BXP. The proof of the SBXP in the finite-range case (see the proof of Theorem 2.16) can be adapted easily to well decorrelated cases, using similar coupling arguments. \square

3. APPLICATIONS

3.1. Discrete Gaussian fields. We begin the description of our first concrete example with the statement of a decorrelation result for Gaussian vectors, which will play a similar role below as Theorem 4.3 did in [1].

Definition 3.1 (Shifted truncation). *Let $A = (a_{ij})$ be a symmetric $n \times n$ matrix, and let $\delta > 0$ be given. The shifted truncation of A at level δ with shift ε is the (symmetric) matrix $T_{\delta, \varepsilon}(A) = (b_{ij})$ defined by*

$$b_{ij} := a_{ij}1_{|a_{ij}| > \delta} + \varepsilon 1_{i=j}.$$

Theorem 3.2. *Let $X = (x_i)$ be a centered Gaussian vector in \mathbb{R}^n with covariance matrix $A = (a_{ij})_{1 \leq i, j \leq n}$ satisfying $\forall 1 \leq i \leq n, a_{ii} = 1$, and let $\delta \in (0, 1/n)$. Then, the shifted truncation $B = T_{\delta, (n\delta)^{3/5}}(A)$ is a positive matrix, and there exists a coupling of X with another centered Gaussian vector $Y = (y_i)$ with covariance matrix B such that*

$$\mathbf{P}[\forall i \in [1, n], x_i y_i > 0] \geq 1 - 3n^{6/5} \delta^{1/5}.$$

Proof. The proof goes in two steps. Let $\varepsilon > 0$ be fixed for now, and let $C = A + \varepsilon I_n$. A Gaussian vector $Z = (z_i)_{1 \leq i \leq n}$ with covariance matrix C can be realized explicitly as the independent sum of $X = (x_i)_{1 \leq i \leq n}$ and a vector $E = (e_i)_{1 \leq i \leq n}$ with i.i.d. $\mathcal{N}(0, \varepsilon)$ coordinates. Then for every i and any $h > 0$,

$$\mathbf{P}[x_i z_i \leq 0] \leq \mathbf{P}[|e_i| \geq |x_i|] \leq \mathbf{P}[|x_i| < h] + \mathbf{P}[|e_i| > h] \leq 2h/\sqrt{2\pi} + \varepsilon/h^2.$$

Choosing $h = \varepsilon^{1/3}$ gives $\mathbf{P}[x_i z_i \leq 0] \leq 2\varepsilon^{1/3}$; in particular, the coordinates of X and Z share the same sign outside an event of probability at most $\eta_1 = 2n\varepsilon^{1/3}$.

Now, let $B = T_{\delta, \varepsilon}(A)$. For every vector $V = (v_i)$,

$$(3.1) \quad V^t B V = V^t A V + \varepsilon \|V\|_2^2 - \sum_{i,j} a_{ij} v_i v_j 1_{|a_{ij}| \leq \delta} \geq (\varepsilon - n\delta) \|V\|_2^2$$

so every eigenvalue of B is at least equal to $\varepsilon - n\delta$. From now on we will assume that ε satisfies the condition $\varepsilon > n\delta$; this ensures the positivity of the matrix B , and will hold for our final choice of ε below.

If Y is a Gaussian vector of covariance B , then the total variation distance between Y and Z can be estimated using Pinsker's inequality:

$$4d_{TV}^2(Y, Z) \leq \text{tr } C^{-1} B - \log \det C^{-1} B - n.$$

Notice that writing $D := B - C$, we have $C^{-1} B = C^{-1}(C + D) = I_n + C^{-1} D$. The entries of D are bounded by δ and those of C^{-1} by ε^{-1} so those of $C^{-1} D$ are bounded by $n\delta/\varepsilon$. By

the Gershgorin circle theorem, every eigenvalue λ of $I_n + C^{-1}D$ satisfies $|\lambda - 1| \leq n^2\delta/\varepsilon$. This directly implies that

$$|\operatorname{tr} C^{-1}B - n| \leq n^3\delta/\varepsilon.$$

On the other hand, if we assume in addition that $\varepsilon \geq 2n^2\delta$,

$$|\log \det C^{-1}B| \leq -n \log(1 - n^2\delta/\varepsilon) \leq 2n^3\delta/\varepsilon.$$

To sum up, Pinsker's inequality shows that Y and Z can be coupled in such a way that they coincide, and therefore their coordinates have the same signs, outside an event of probability at most $\eta_2 = \frac{1}{2}\sqrt{3n^3\delta/\varepsilon} \leq n^{3/2}\delta^{1/2}\varepsilon^{-1/2}$.

Combining both steps, X and Y can be coupled so that their coordinates have the same signs outside an event of probability

$$\eta_1 + \eta_2 \leq 2n\varepsilon^{1/3} + n^{3/2}\delta^{1/2}\varepsilon^{-1/2}.$$

Choosing $\varepsilon = (n\delta)^{3/5}$ leads, as announced, to

$$\eta_1 + \eta_2 \leq 3n^{6/5}\delta^{1/5}.$$

With this choice of ε , the assumption $\varepsilon \geq 2n^2\delta$ can be rewritten as $2n^{7/5}\delta^{2/5} \leq 1$; if that fails to be the case, then the upper bound we claim on the total variation distance is at least equal to $3.2^{-1/2}n^{5/10} > 1$ so it holds vacuously, thus ending the proof. \square

This theorem implies a variant of Theorem 4.3 in [1] (see also [2]), with a slightly better upper bound:

Corollary 3.3. *Let X and Y be two Gaussian vectors in \mathbb{R}^{m+n} , respectively of covariance*

$$\Sigma_X = \begin{bmatrix} \Sigma_1 & \Sigma_{12} \\ \Sigma_{12}^T & \Sigma_2 \end{bmatrix} \quad \text{and} \quad \Sigma_Y = \begin{bmatrix} \Sigma_1 & 0 \\ 0 & \Sigma_2 \end{bmatrix},$$

where $\Sigma_1 \in M_m(\mathbb{R})$ and $\Sigma_2 \in M_n(\mathbb{R})$ have all diagonal entries equal to 1. Denote by μ_X (resp. μ_Y) the law of the signs of the coordinates of X (resp. Y), and by η the largest absolute value of the entries of Σ_{12} . Then,

$$d_{TV}(\mu_X, \mu_Y) \leq 6(m+n)^{6/5}\eta^{1/5}.$$

Proof. We first apply Theorem 3.2 to the vector X , in dimension $m+n$, with $\delta = \eta$: this leads to a coupling of X with a Gaussian vector X' of covariance matrix $\Sigma'_X = T_{\eta, (n\eta)^{3/5}}(\Sigma_X)$, so that the coordinates of X and X' have pairwise identical signs outside an event of probability $3(m+n)^{6/5}\eta^{1/5}$. Similarly, Theorem 3.2 provides a coupling of Y with a vector Y' with covariance matrix $\Sigma'_Y = T_{\eta, (n\eta)^{3/5}}(\Sigma_Y)$, whose coordinates have the same signs as those of Y outside an event of the same probability. It is easy to check that the definition of η ensures that $\Sigma'_X = \Sigma'_Y$, so X' and Y' have the same definition, thus concluding the proof. \square

For any lattice \mathcal{T} invariant under translation, define $n_{\mathcal{T}}$ the number of vertices of \mathcal{T} contained in the unit square $[0, 1]^2$, which we will think of as the lattice density in the plane (which it is when none of the vertices lies on the boundary of the unit square). In what follows, $\|\cdot\|$ stands for the ℓ^∞ norm.

Corollary 3.4. *There exists a universal constant $C > 0$, such that the following holds. Let \mathcal{T} be any planar lattice invariant under integer translations, and f be any stationary Gaussian stationary field on \mathbb{R}^2 with covariance kernel K satisfying $K(0) = 1$; let $\delta_K(d) := \max_{\|x\| \geq d} |K(x)|$. Then, (f, \mathcal{T}) is θ -decorrelated for a function θ satisfying*

$$\forall n \geq 1, \forall d > 0, \theta(n, d) \leq 16n_{\mathcal{T}}^{6/5} n^{12/5} \delta_K(d)^{1/5}.$$

In particular, if $|K(x)| \leq 1 \wedge c\|x\|^{-D}$, there exists $C < \infty$ such that uniformly,

$$\theta(n, d) \leq Cn_{\mathcal{T}}^{6/5} n^{12/5} d^{-D/5}.$$

Proof. For $n \in \mathbb{N}$, let $N_n := |\mathcal{T} \cap [-n, n]^2| \leq 4n\tau n^2$ and let X be the Gaussian vector in \mathbb{R}^{N_n} whose entries are the values of f at the vertices of $\mathcal{T} \cap [-n, n]^2$. By Theorem 3.2, there exists a coupling of X with a Gaussian vector Y such that with probability at least $1 - 3N_n^{6/5} \delta(d)^{1/5}$, the coordinates of X have the same signs as those of Y , and such that any entry of the covariance matrix of Y vanishes if the associated entry of X is less than $\delta(d)$. The vector Y is the restriction to $\mathcal{T} \cap [-n, n]$ of a stationary Gaussian field with correlation range at most d (stationarity is easily seen from the definition of shifted truncation). The corollary follows directly, noting that $3(4)^{6/5} \leq 16$. \square

Proof of Theorem 1.16. Since $D > 24$, by Corollary 3.4, for any $u \in [0, 1]$, $(f_u, \mathcal{T})_{u \in [0, 1]}$ is uniformly well decorrelated, with $\alpha = 12/5$ and $\beta = D/5 > 2\alpha$. Theorem 1.12 concludes. \square

3.2. The Ising model. In order to prove Theorem 1.18, we need to check that the assumptions for our general result apply for $|\beta|$ small enough. Both continuity and decorrelation will follow from the following coupling result, which can be seen as a variant of the *disagreement percolation* construction in [4] or the proof of *bernoullicity* in [9] and uses coupling from the past ideas from [14, 15]. To keep the article self-contained we will provide all the necessary theory below; the key difference with the classical literature is that we work in infinite volume.

Theorem 3.5. *Let \mathcal{T} be a periodic triangulation of the plane, N be the maximum degree of the vertices of \mathcal{T} , and $\beta_0 > 0$ be such that $N \tanh \beta_0 N < 1$. Then,*

- (1) *For every $\beta \in [-\beta_0, \beta_0]$, the Ising model on \mathcal{T} at inverse temperature β has a unique infinite-volume Gibbs measure μ_β ; in particular, if \mathcal{T} is symmetric, then so is the random colouring of law μ_β , see Definition 1.1.*
- (2) *The measures $(\mu_\beta)_{\beta \in [-\beta_0, \beta_0]}$ are uniformly decorrelated at rate*

$$\theta(n, \ell) \leq Cn^2 e^{-c\ell}$$

with $C < \infty$ and $c = -\frac{1}{2} \log(N \tanh \beta_0 N) > 0$.

Proof of Theorem 1.18. By Theorem 3.5, the family of measures $(\mu_\beta)_{\beta \in [-\beta_0, \beta_0]}$ satisfies the hypotheses of Theorem 1.12, so that Theorem 1.18 holds. \square

Proof of Theorem 3.5. The existence of a Gibbs measure follows from general compactness arguments. Uniqueness for small β can be derived for instance from Dobrushin's uniqueness criterion, or obtained as an instance of corollary 2 in [4]. We will obtain it as a consequence of the construction that we are going to describe. For the moment, let μ_β be any Gibbs measure at inverse temperature β .

Let first v be a vertex in \mathcal{T} , and let $\tilde{\sigma}$ be a configuration on \mathcal{T} . The conditional distribution of σ_v under μ_β , given the configuration outside $\{v\}$, is given by

$$p(v|\tilde{\sigma}) := \mu_\beta [\sigma_v = +1 | \sigma_{\mathcal{V} \setminus \{v\}} = \tilde{\sigma}_{\mathcal{V} \setminus \{v\}}] = \frac{e^{\beta n(v, \tilde{\sigma})}}{e^{\beta n(v, \tilde{\sigma})} + e^{-\beta n(v, \tilde{\sigma})}},$$

where we denoted by $n(v, \tilde{\sigma})$ the sum of all the σ_u for u in the neighbors of v in \mathcal{T} . Since N is the maximum degree of a vertex in \mathcal{T} , we know that $n(v, \tilde{\sigma}) \in [-N, N]$ so

$$\frac{e^{-|\beta|N}}{e^{-|\beta|N} + e^{|\beta|N}} \leq p(v|\tilde{\sigma}) \leq \frac{e^{|\beta|N}}{e^{-|\beta|N} + e^{|\beta|N}}.$$

Uniformly in $\beta \in [-\beta_0, \beta_0]$, this implies

$$(3.2) \quad \left| p(v|\tilde{\sigma}) - \frac{1}{2} \right| \leq \frac{e^{\beta_0 N}}{e^{-\beta_0 N} + e^{\beta_0 N}} - \frac{1}{2} = \frac{1}{2} \tanh(\beta_0 N).$$

This gives a way to sample σ_x according to its conditional distribution:

- First sample a Bernoulli random variable ε with parameter $\delta := \tanh(\beta_0 N)$;

- If $\varepsilon = 0$, sample a symmetric \pm spin ω and set σ_x to its value;
- If $\varepsilon = 1$, sample a uniform variable $U \in [0, 1]$ and set $\sigma_x = +1$ if $U < q(v|\tilde{\sigma})$, with

$$(3.3) \quad q(v|\tilde{\sigma}) := \frac{1}{2} + \frac{p(v|\tilde{\sigma}) - 1/2}{\delta} \in [0, 1].$$

It is easy to check that σ_x has the right conditional distribution, in other words

$$p(v|\tilde{\sigma}) = (1 - \delta)\frac{1}{2} + \delta q(v|\tilde{\sigma}).$$

This provides an explicit construction of a stationary Markov chain for the measure μ_β : at every vertex v of \mathcal{V} , at rate 1, resample σ_v given the neighboring configuration by first sampling an independent copy of the triple (ε, ω, U) , and then applying the above construction.

We now implement the coupling from the past construction associated to the above Markov chain. More precisely, for every $v \in \mathcal{V}$, let $T_v = (T_{v,i})_{i>0}$ be an independent Poisson process with intensity 1 on $(-\infty, 0)$ and to each of its points associate a triple $(\varepsilon_{v,i}, \omega_{v,i}, U_{v,i})$ of independent random variable variables, respectively Bernoulli with parameter δ , ± 1 with probability $1/2$, and uniform in $[0, 1]$. For $t < 0$, denote by \mathcal{X}_t the collection of all the $(T_{v,i}, \varepsilon_{v,i}, \omega_{v,i}, U_{v,i})$ for which $t < T_{v,i} < 0$ and by T_t the transformation from $\{\pm\}^\mathcal{V}$ to itself obtained by following the Glauber dynamics described above on the time interval $(t, 0)$ with the randomness provided by \mathcal{X}_t . The fact that T_t is well-defined for all t even though \mathcal{V} is infinite follows from classical arguments of statistical mechanics, which we do not reproduce here. It is clear that the measure μ_β is preserved by T_t .

The main statement of the Propp-Wilson theory is that, in a similar setup, if t is chosen negative enough so that T_t is constant on $\{\pm\}^\mathcal{V}$, or in other words, if the configuration σ at time 0 obtained from the construction depends only on \mathcal{X}_t and not on the configuration at time $t < 0$, then it is distributed exactly according to the stationary measure. The existence of such a time is nontrivial in general, and cannot hold in infinite volume; but we still get our intuition from the finite case: rather than taking a random t for which we get the exact distribution, we will choose a deterministic t and show that we obtain a distribution that is close enough to μ_β for our purposes.

One useful remark is that the coupling from the past construction can be implemented backwards in time: to determine the state of a vertex $v \in \mathcal{V}$, start at time 0 and explore the process for negative times, to form a tree as follows. Every time a mark of a Poisson process is met on a branch, either it has $\varepsilon = 0$, in which case it is enough to determine the color of the branch (because it is given by the local value of ω), or it has $\varepsilon = 1$ and then one needs to know the state of the neighbors to compute the local value of the threshold q : to do that one needs to branch out the exploration into as many sub-branches as there are neighbors. Let $\rho(v, s)$ be the expected number of branches that are still being traced at time $-s$ when starting at vertex v : each branch, at rate 1, meets a Poisson mark, and we get a differential inequality

$$(3.4) \quad \partial_s \rho(v, s) \leq \rho(v, s)[\delta(N - 1) - (1 - \delta)] = \rho(v, s)(\delta N - 1)$$

corresponding to the two scenarios (remember that N is the maximal degree of \mathcal{T}). In particular, as soon as $\delta < 1/N$, the right-hand term is negative and $\rho(v, s)$ decays exponentially:

$$(3.5) \quad \forall v \in \mathcal{V}, \forall s \geq 0, \rho(v, s) \leq e^{-\lambda s} \quad \text{for } \lambda := 1 - N\delta > 0.$$

In particular, by a union bound, the probability that all the vertices in a box Λ have their states determined by \mathcal{X}_t is at least equal to $1 - |\Lambda|e^{-\lambda t}$.

This gives a candidate for a simpler model μ_β^t that couples well with μ_β : given \mathcal{X}_t , for every vertex v , if the state of σ_v can be determined using \mathcal{X}_t as above, use the output of the algorithm; if it cannot, sample its state to be \pm with probability $1/2$, independently

of everything else. From the above discussion, configurations of laws μ_β and μ_β^t can be coupled to coincide in the box $|\Lambda|$ outside an event of probability at most $|\Lambda e^{-\lambda t}|$.

This is not quite what we were looking for yet, because the measure μ_β^t does not have finite range. One can get by with percolation arguments, but a simpler construction is as follows. Fix $k > 0$; implement the same tracing back of the Poisson process from time 0, but instead of stopping at time t , stop when the exploration tree reaches depth k . In other words, stop tracing back the history of the process after at most k generations.

Let $\rho_k(v)$ be the expected number of branches that are still being traced after k generations: the same reasoning as before, applied at the discrete times of the Poisson points, leads to $\rho_{k+1}(v) \leq \delta N \rho_k(v)$, hence $\rho_k(v) \leq (\delta N)^k$. If $\delta < 1/N$, which we will assume from now on, this gives exponential decay as before. Applying the same construction, tracing back the Poisson processes for k generations and then sampling sites whose state is not yet determined independently of everything else, one obtains a measure $\mu_{\beta,k}$ on $\{\pm 1\}^{\mathcal{V}}$.

We are now ready to conclude the proof. The measure $\mu_{\beta,k}$ has finite range $2k$, because the state of a vertex v depends only on the restriction of the Poisson processes to the ball of radius k around v ; μ_β and $\mu_{\beta,k}$ can be coupled so that they agree within a given set Λ outside an event of probability at most $|\Lambda|(\delta N)^k$; taking $k = \ell/2$ gives the bound

$$\theta(n, \ell) \leq Cn^2(\delta N)^{\ell/2} = Cn^2(N \tanh \beta_0 N)^{\ell/2}. \quad \square$$

Remark 3.6. *The method we use here to get an upper bound on θ is extremely general, and can be applied to many other cases. For spin models with finite energy and short-range interactions (i.e., nearest-neighbor interactions on a bounded degree graph), only minor details need to be adapted. It would be interesting to see whether similar bounds can be obtained for the self-dual random-cluster model with cluster parameter q close to 1: there, the parameter δ is still small, but the number of offspring of a branching individual in the tree, rather than being bounded by N , becomes a highly non-local function of the configuration, but finite expectation would be enough for many of our purposes.*

APPENDIX A. A SMOOTHED RANDOM WAVE MODEL.

Let (M, g) be a compact smooth Riemannian manifold, and Δ be its associated Laplacian. For any smooth function $\chi : \mathbb{R}^+ \rightarrow \mathbb{R}^+$ with compact support containing 1, and any $L > 0$, define the random function

$$f_{\chi,L} = \sum_{i \in \mathbb{N}} a_i \chi\left(\frac{\lambda_i}{L}\right) \varphi_i,$$

where the a_i are independent Gaussian random variables of variance 1, and $(\varphi_i)_i$ is a Hilbert orthonormal basis of eigenfunctions of Δ associated to the eigenvalues $(\lambda_i)_i$. Then the associated kernel $K_{\chi,L}$, in normal coordinates near a point $x_0 = 0$, satisfies (see [11])

$$\forall (x, y) \in \mathbb{R}^n, K_L\left(\frac{x}{L}, \frac{y}{L}\right) \xrightarrow{L \rightarrow \infty} K_\chi(x, y),$$

where

$$K_\chi(x, y) = \int_{\xi \in \mathbb{R}^2} \chi(\|\xi\|^2) e^{i\langle x-y, \xi \rangle} d\xi.$$

The smoothness of χ implies that K_χ decays faster than any negative power of the distance. This model can be seen as an approximation of the random wave model, where $\chi = \delta_1$. More precisely, consider the random sum of wave

$$(A.1) \quad \forall x \in \mathbb{R}^2, g(x) = \sum_{m=-\infty}^{\infty} a_m J_{|m|}(r) e^{im\varphi}$$

Here (r, φ) denotes the polar coordinates of x , J_k denotes the k -th Bessel function, and $(a_m)_{m \in \mathbb{Z}}$ are independent normal coefficients. The correlation function for this model equals (see [6])

$$(A.2) \quad K(x, y) = \int_{\xi \in \mathbb{R}^2, \|\xi\|=1} e^{i\langle x-y, \xi \rangle} d\xi = J_0(\|x - y\|).$$

In [5] and [6], the authors conjectured that the latter model should be related to some percolation model. Note that K decays polynomially in this distance with degree $1/2$, so it does not enter our setting.

The kernel K_χ defines a random Gaussian field f_χ on \mathbb{R}^2 , which we call here the *smoothed random wave model* associated to χ . Since J_0 oscillates and since K_χ converges on compacts to K when $\chi \rightarrow \delta_1$, for every $R > 0$ and every degree $d > 10$, it gives an example of a correlation function satisfying the condition (1.1) with degree at least d , and which oscillates outside the ball of radius R .

REFERENCES

- [1] V. BEFFARA AND D. GAYET, *Percolation of random nodal lines*, to appear in Publ. Math. Inst. Hautes Études Sci., arXiv:1605.08605, DOI: 10.1007/s10240-017-0093-0, (2016).
- [2] D. BELIAEV AND S. MUIRHEAD, *Discretisation schemes for level sets of planar Gaussian fields*, arXiv preprint 1702.02134, (2017).
- [3] D. BELIAEV, S. MUIRHEAD, AND I. WIGMAN, *Russo-Seymour-Welsh estimates for the Kostlan ensemble of random polynomials*, arXiv preprint 1709.08961, (2017).
- [4] J. VAN DEN BERG AND C. MAES, *Disagreement percolation in the study of Markov fields.*, Ann. Probab., 22 (1994), pp. 749–763.
- [5] E. BOGOMOLNY AND C. SCHMIT, *Percolation model for nodal domains of chaotic wave functions*, Phys. Rev. Lett., 88 (2002), p. 114102.
- [6] ———, *Random wavefunctions and percolation*, J. Phys. A, Math. Theor., 40 (2007), pp. 14033–14043.
- [7] H. DUMINIL-COPIN, C. HONGLER, AND P. NOLIN, *Connection probabilities and RSW-type bounds for the two-dimensional FK Ising model*, Communications on Pure and Applied Mathematics, 64 (2011), pp. 1165–1198.
- [8] G. GRIMMETT, *Percolation*, Berlin: Springer, 2nd ed. ed., 1999.
- [9] O. HAGGSTROM, J. JONASSON, AND R. LYONS, *Coupling and Bernoullicity in random-cluster and Potts models*, Bernoulli, 8 (2001), pp. 275–294.
- [10] T. E. HARRIS, *A lower bound for the critical probability in a certain percolation process*, Mathematical Proceedings of the Cambridge Philosophical Society, 56 (1960), pp. 13–20.
- [11] L. HÖRMANDER, *The spectral function of an elliptic operator*, Acta Math., 121 (1968), pp. 193–218.
- [12] H. KESTEN, *Analyticity properties and power law estimates of functions in percolation theory*, Journal of Statistical Physics, 25 (1981), pp. 717–756.
- [13] L. D. PITT, *Positively Correlated Normal Variables are Associated*, The Annals of Probability, 10 (1982), pp. 496–499.
- [14] J. G. PROPP AND D. B. WILSON, *Exact sampling with coupled Markov chains and applications to statistical mechanics*, Random Structures and Algorithms, 9 (1996), pp. 223–252.
- [15] ———, *Coupling from the past: A user’s guide.*, in Microsurveys in discrete probability. DIMACS workshop, Princeton, NJ, USA, June 2–6, 1997, Providence, RI: AMS, American Mathematical Society, 1998, pp. 181–192.
- [16] A. RIVERA AND H. VANNEUVILLE, *Quasi-independence for nodal lines*, arXiv preprint 1711.05009, (2017).
- [17] L. RUSSO, *A note on percolation*, Zeitschrift für Wahrscheinlichkeitstheorie und Verwandte Gebiete, 43 (1978), pp. 39–48.
- [18] P. D. SEYMOUR AND D. J. A. WELSH, *Percolation Probabilities on the Square Lattice*, Annals of Discrete Mathematics, 3 (1978), pp. 227–245.
- [19] V. TASSION, *Crossing probabilities for Voronoi percolation*, Ann. Probab., 44 (2016), pp. 3385–3398.