



HAL
open science

Parametric pipe detection on the urban site Sense-City using Ground-Penetrating Radar (GPR)

Florence Sagnard, Christophe Norgeot, Xavier Derobert, Vincent Baltazart,
Erick Merliot, François Derkx, Bérengère Lebental

► To cite this version:

Florence Sagnard, Christophe Norgeot, Xavier Derobert, Vincent Baltazart, Erick Merliot, et al.. Parametric pipe detection on the urban site Sense-City using Ground-Penetrating Radar (GPR). EGU - European Geosciences Union General Assembly 2016, Apr 2016, Vienna, Austria. EGU - European Geosciences Union General Assembly 2016, 1p, 2016. hal-01615713

HAL Id: hal-01615713

<https://hal.science/hal-01615713v1>

Submitted on 12 Oct 2017

HAL is a multi-disciplinary open access archive for the deposit and dissemination of scientific research documents, whether they are published or not. The documents may come from teaching and research institutions in France or abroad, or from public or private research centers.

L'archive ouverte pluridisciplinaire **HAL**, est destinée au dépôt et à la diffusion de documents scientifiques de niveau recherche, publiés ou non, émanant des établissements d'enseignement et de recherche français ou étrangers, des laboratoires publics ou privés.



Parametric pipe detection on the urban site Sense-City using Ground-Penetrating Radar (GPR)

F. Sagnard¹, Ch. Norgeot², X. Derobert¹, V. Baltazart¹, E. Merliot¹, F. Derkx¹, B. Lebental¹

¹COSYS, University Paris-Est, Champs-sur-Marne, France

²MDS, Paris, France

Objectives

- Mapping the underground in a urban landscape with a non-destructive technique using electromagnetic waves to detect dielectric discontinuities
- Parametric detection of dielectric and conductive utilities with relative small diameters buried in different types of soils (nature, composition, moisture content) using ground-coupled georadars at several frequencies in the band [0.3;4] GHz
- Development of signal and image processing techniques for clutter removal, hyperbola detection and fitting, object and soil characterization

Experiments in the test site Sense-city

General view of the mini-city test bed



Top views

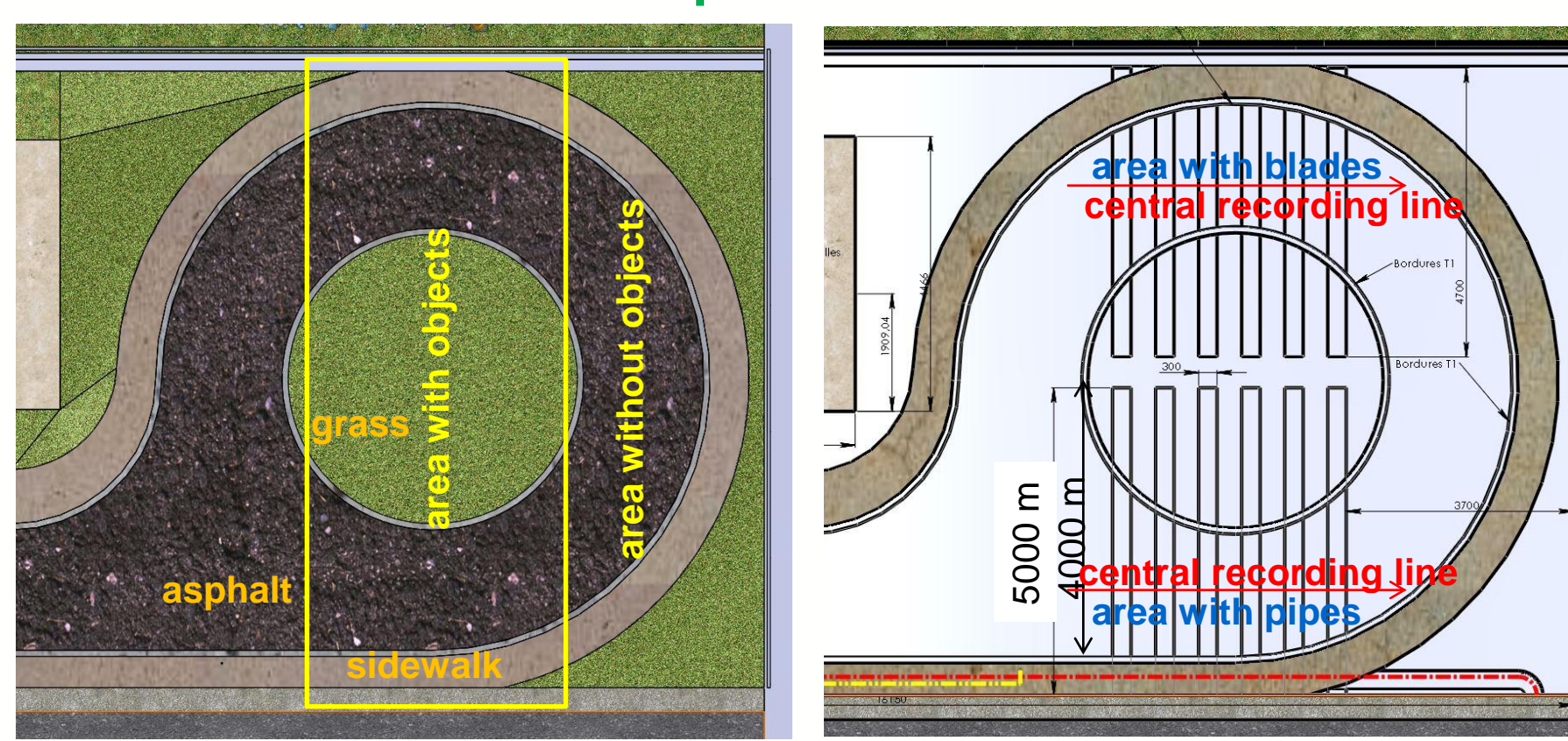

Distribution of the buried pipes/blades

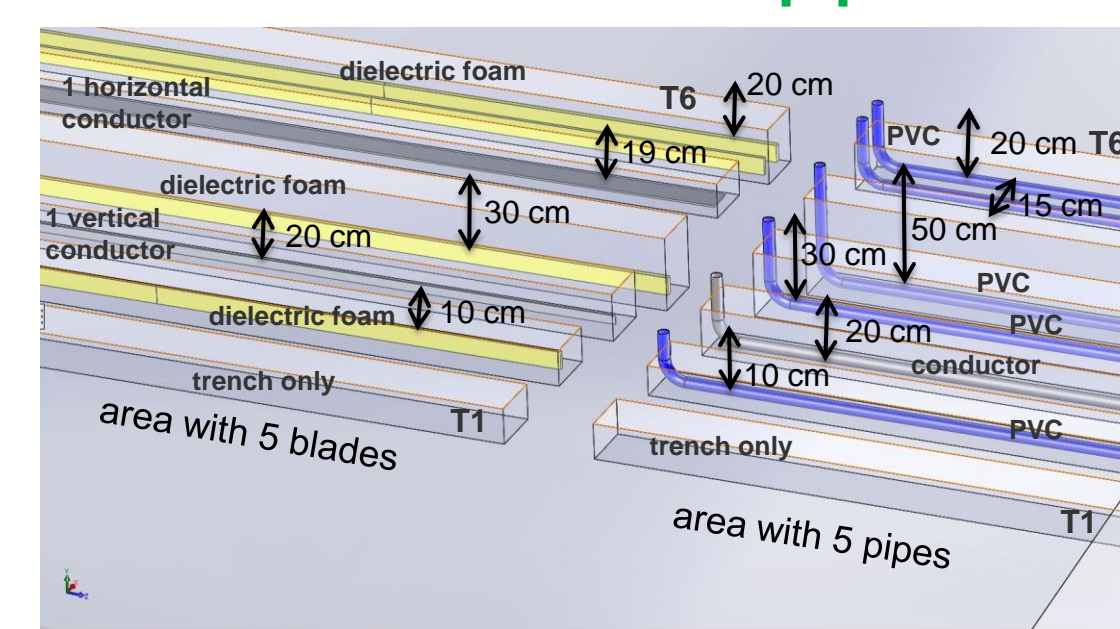

Mapping the urban underground

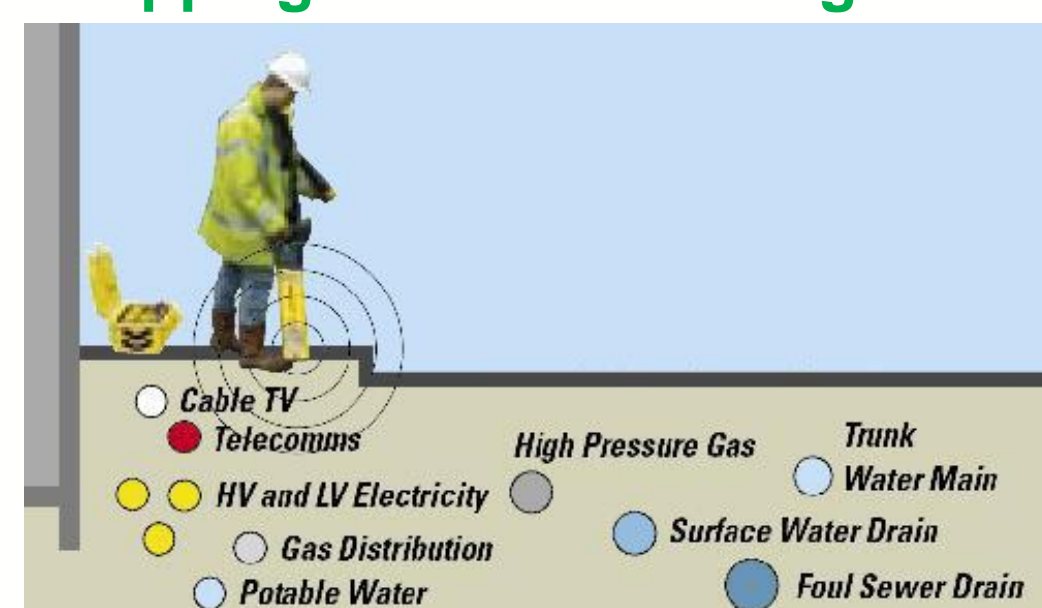

Structure of the subsurface

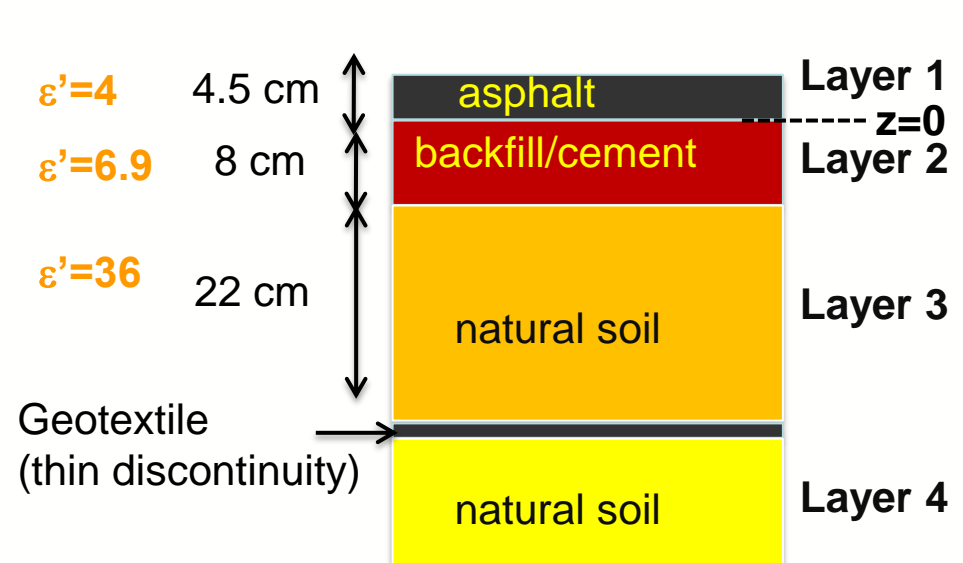

Buried objects

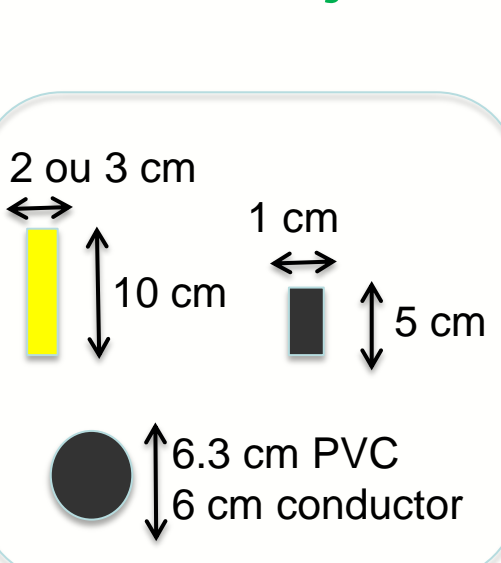

Commercial GPR systems operating in the time domain

500 MHz (SIR 3000)



Double frequency 300-800 MHz (UtilityScan DF)



Laboratory-made GPR system operating in the frequency domain (FMCW)

Polarization TM

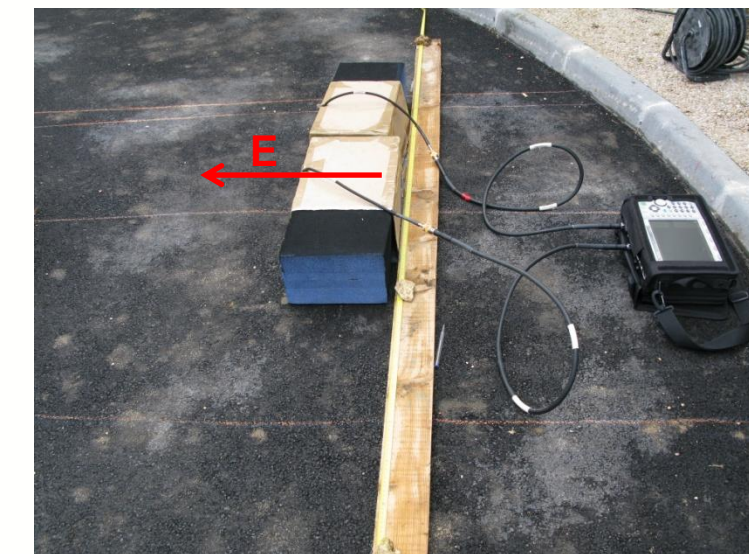

Polarization TE



Measurements in the pipe area

A cut view of the pipe zone

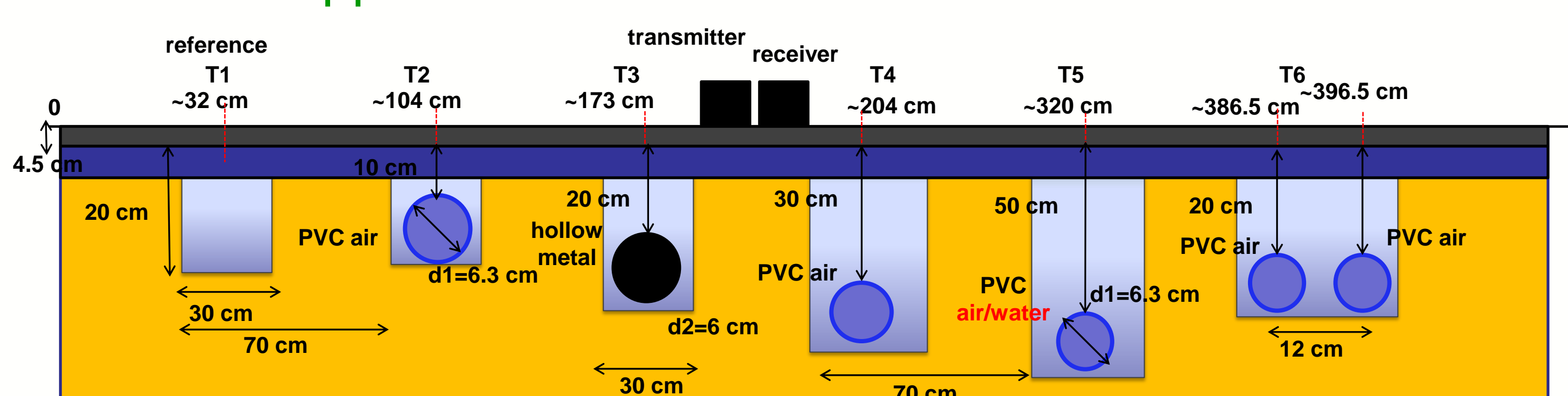

Measurements in the frequency domain

Radargrams at 900 MHz (with gain)

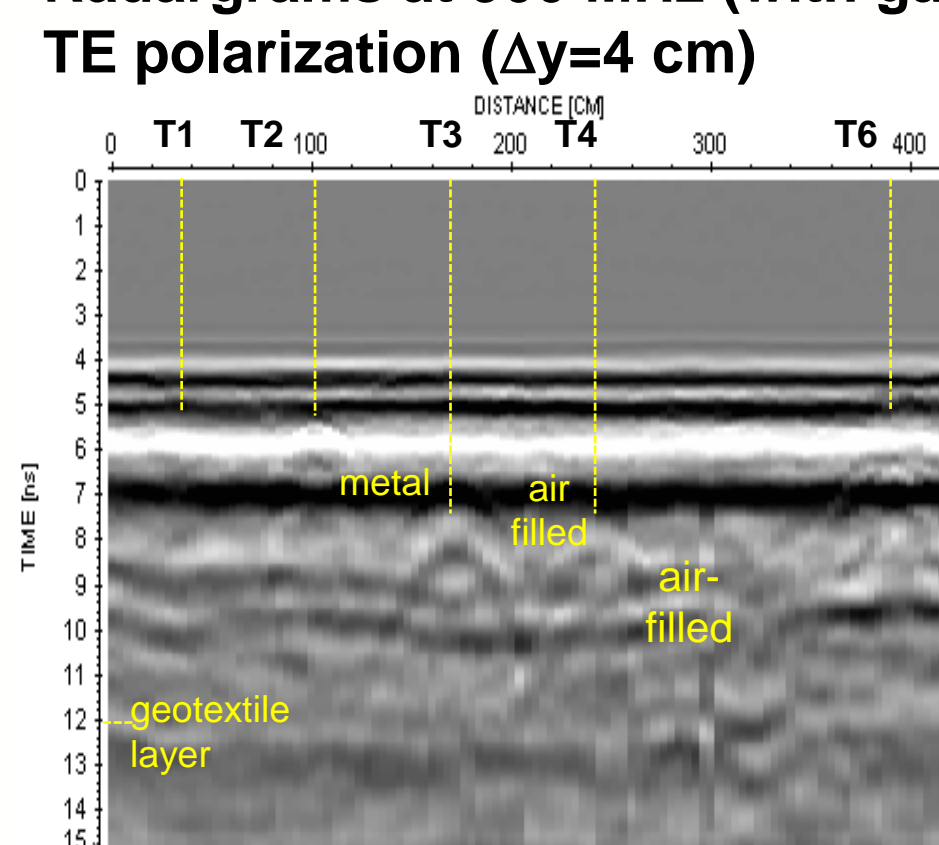

TM polarization

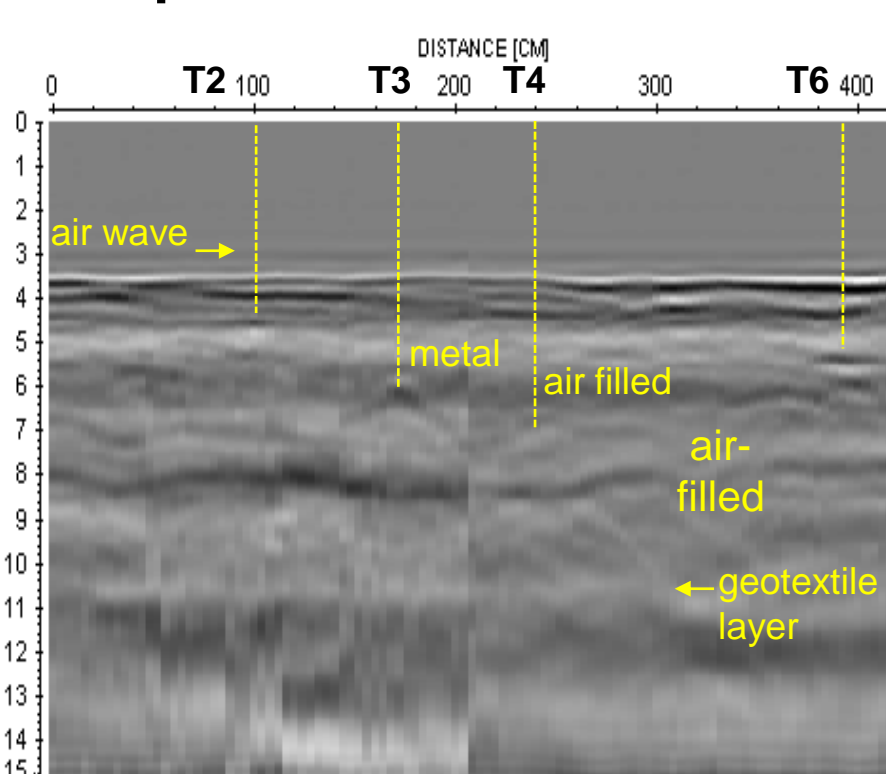

Measurements in the time domain

Soil characterization at 900 MHz (with linear gain, $\Delta y \sim 1$ cm)

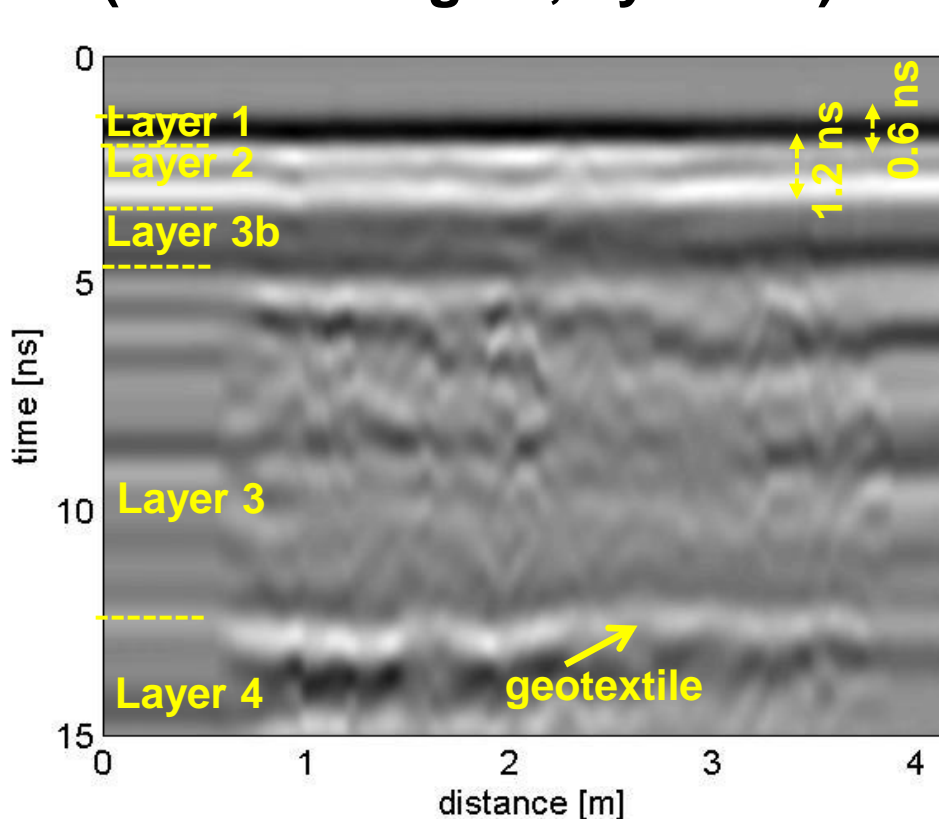

Pipe radargram (with linear gain) 500 MHz ($\Delta y \sim 1$ cm)

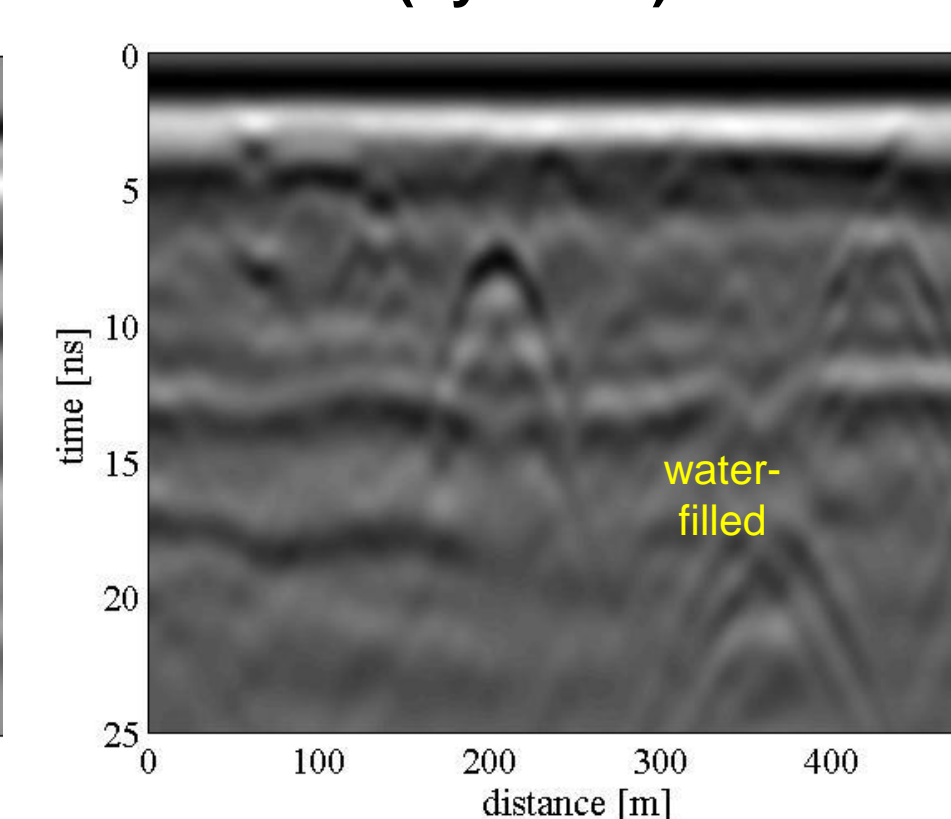

900 MHz

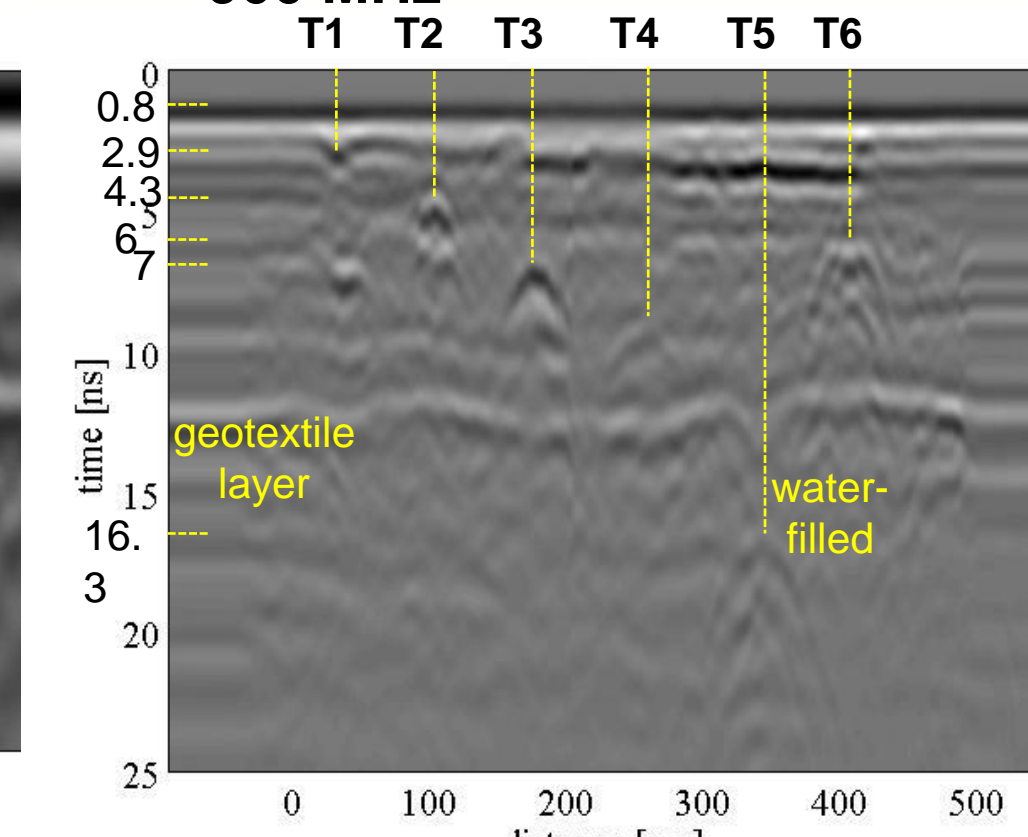

- Images of the pipe zone using 3 different GPR systems (SIR 3000, Utility scan with 2 frequencies, radar FMCW) at the following nominal frequencies :
 - 500 MHz, 900 MHz, 1600 MHz
 - 300 et 800 MHz (double frequencies)
 - [50 MHz; 4 GHz] (FMCW, 2 polarizations)
- T5 at depth 54.5 cm : air-filled not detected in the polarization TM, water-filled better detected in the polarization
- 900 MHz appears the best frequency in the compromise between resolution and penetration

Interpretation using migration

800 MHz (with gain)

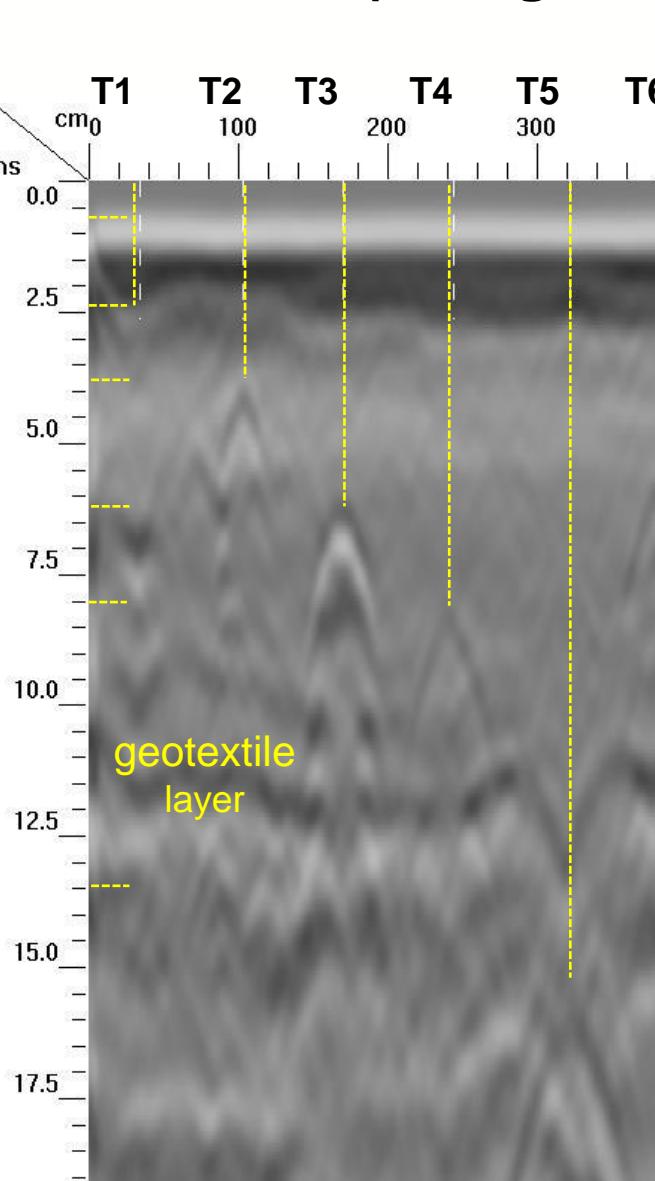

800 MHz (time zero correction and migration $\epsilon^2=12.75$)

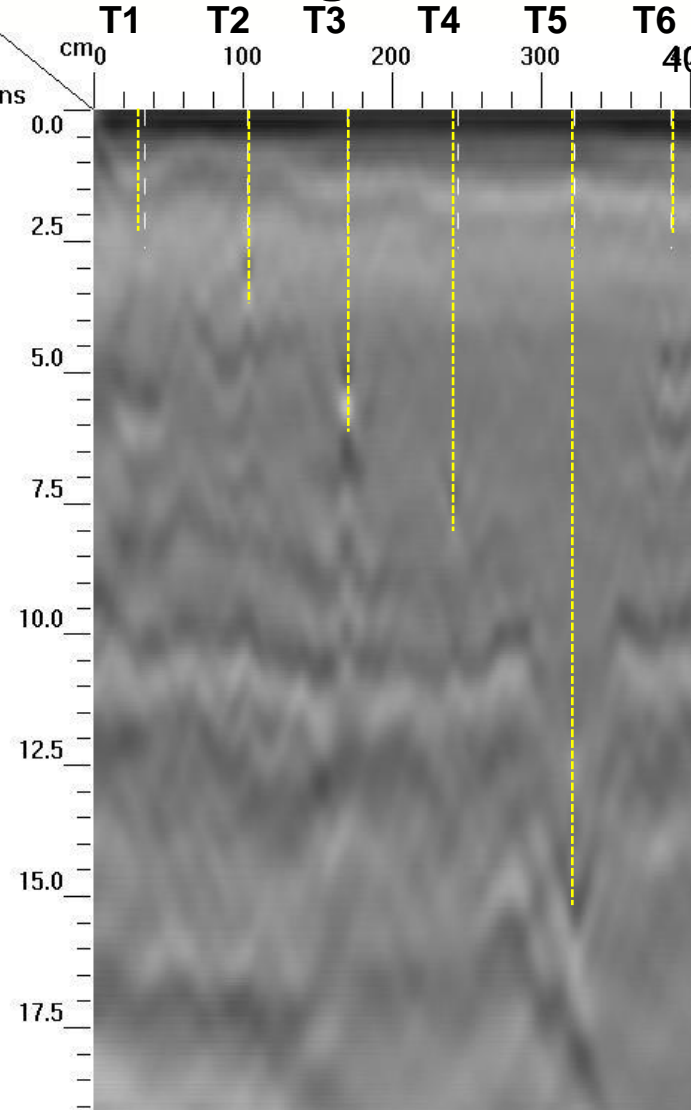

Migration 3D at 800 MHz ($\epsilon^2=12.75$)

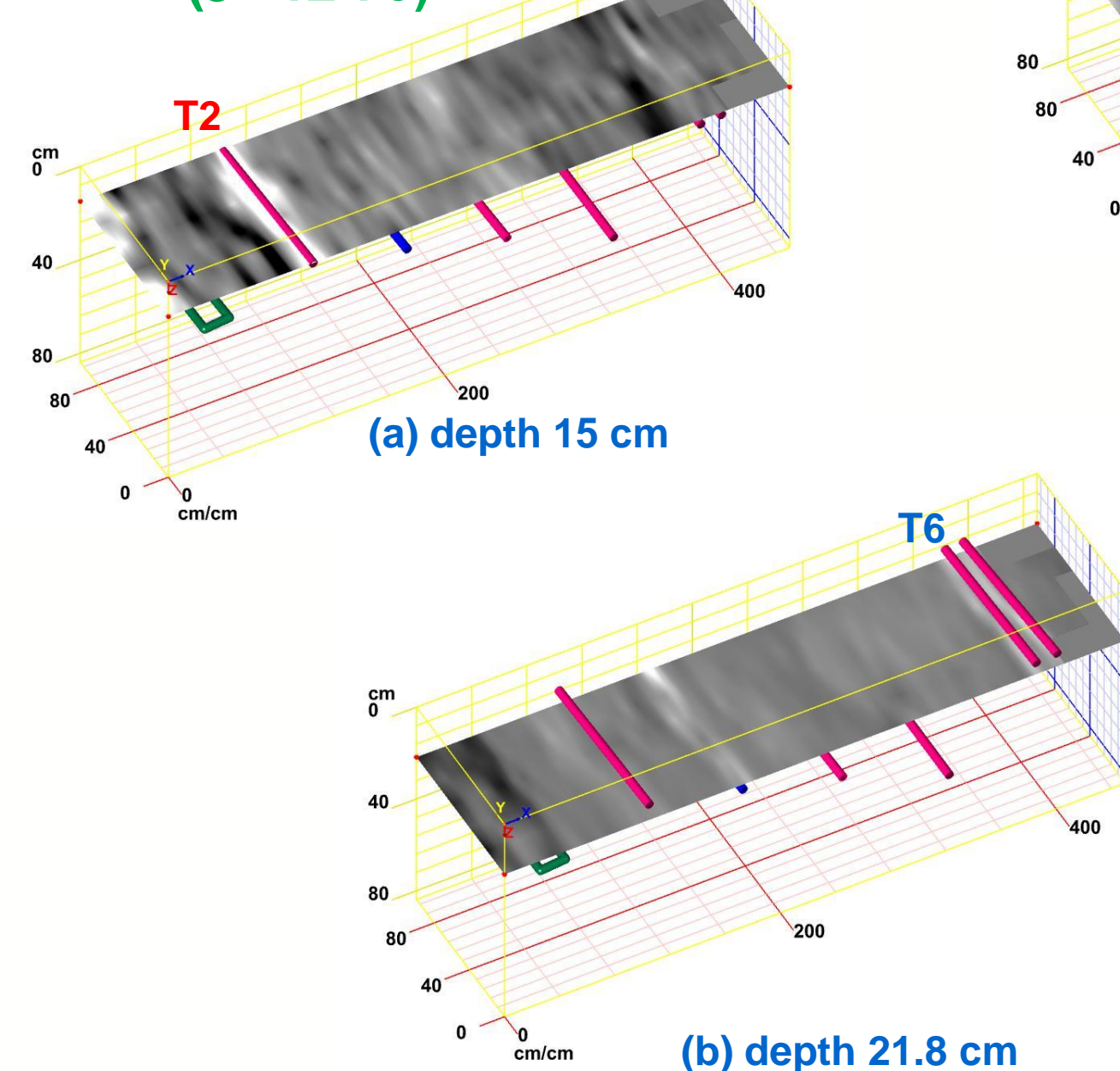

T3

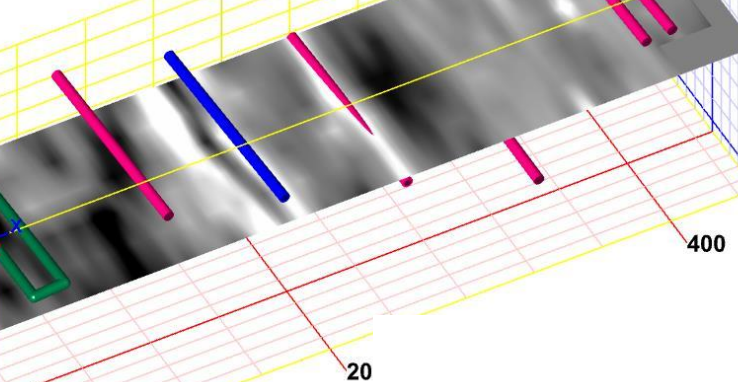

(c) depth 23.6 cm

T4

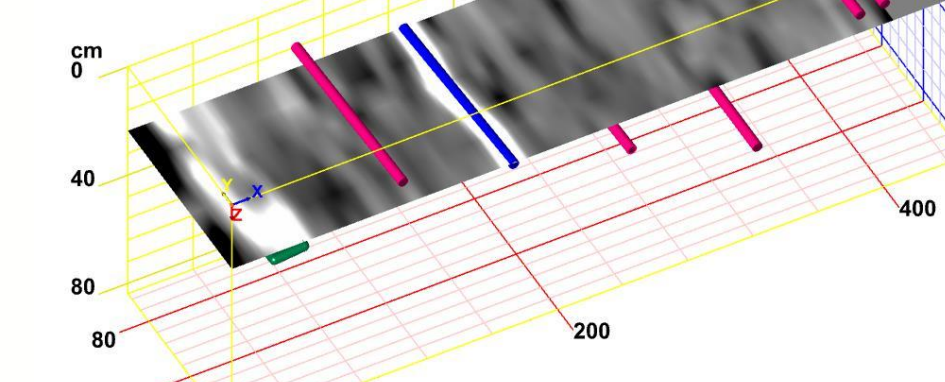

(e) depth 33.4 cm

(d) depth 24.8 cm

(f) depth 49.4 cm