



HAL
open science

A decision support tool for adapting pig feeding strategies to climate change

Jean-Yves Dourmad, Alain Valancogne, Valentine Le Velly, David Renaudeau

► **To cite this version:**

Jean-Yves Dourmad, Alain Valancogne, Valentine Le Velly, David Renaudeau. A decision support tool for adapting pig feeding strategies to climate change. [Contract] 7.1, 2014, 13 p. hal-01611418

HAL Id: hal-01611418

<https://hal.science/hal-01611418>

Submitted on 5 Oct 2017

HAL is a multi-disciplinary open access archive for the deposit and dissemination of scientific research documents, whether they are published or not. The documents may come from teaching and research institutions in France or abroad, or from public or private research centers.

L'archive ouverte pluridisciplinaire **HAL**, est destinée au dépôt et à la diffusion de documents scientifiques de niveau recherche, publiés ou non, émanant des établissements d'enseignement et de recherche français ou étrangers, des laboratoires publics ou privés.



Distributed under a Creative Commons Attribution - ShareAlike 4.0 International License



ANIMALCHANGE

SEVENTH FRAMEWORK PROGRAMME

THEME 2: FOOD, AGRICULTURE AND FISHERIES, AND BIOTECHNOLOGIES



Grant agreement number: FP7- 266018

DELIVERABLE 7.1

Deliverable title: A decision support tool for adapting pig feeding strategies to climate change

Abstract: This deliverable describes a decision support tool developed for adapting feeding strategies of fattening pigs and lactating sows, to climate change, considering different climatic situations in combination with different feeding strategies and animal profiles.

Due date of deliverable: [M36](#)

Actual submission date: [M41](#)

Start date of the project: [March 1st, 2011](#)

Duration: [48 months](#)

Organisation name of lead contractor: [INRA](#)

Contributors: Jean-Yves Dourmad, Alain Valancogne, Valentine Le Velly, David Renaudeau (INRA Agrocampus-Ouest, France)

Version: [V1](#)

Dissemination level: [PU](#)



TABLE OF CONTENTS

1.	CONTEXT	3
2.	OBJECTIVE OF THE DECISION SUPPORT TOOL	4
3.	DESCRIPTION OF THE MODEL	4
3.1.	Prediction of the indoor climate from the outdoor climate	5
3.2.	Prediction of the effect of temperature on feed intake and animal performance from a meta-analysis of literature	6
3.3.	Nutrient use and prediction of performance and requirements	7
4.	SIMULATION RESULTS	10
4.1.	Example of simulations in growing pigs	10
4.2.	Example of simulations in lactating sows	11
5.	CONCLUSION AND PERSPECTIVES	12
6.	LITERATURE CITED	12

A decision support tool for adapting pig feeding strategies to climate change

Jean-Yves Dourmad, Alain Valancogne, Valentine Le Velly, David Renaudeau

INRA Agrocampus-Ouest, UMR Pegase, 35590 Saint-Gilles, France.

jean-yves.dourmad@rennes.inra.fr

1. Context

The increasing risk of occurrence of heat stress periods with climate change will result in decreased performance of pigs, mainly because of the reduction of their voluntary feed intake. In pig production, fattening pigs and lactating sows are the most sensitive to heat stress, because their zone of thermoneutrality is lower than for other pigs and they are generally fed ad libitum. Conversely, post weaning piglets and gestating sows are less sensitive, because of a higher zone of thermoneutrality and the restricted feeding in case of gestating sows, resulting in higher sensitivity to cold stress. This is the reason why it was decided to focus the present project mainly on fattening pigs and lactating sows.

Different strategies may be used to alleviate the effect of heat stress in livestock production as reviewed by Renaudeau et al. (2012). These authors identified three groups of strategies: those aiming at enhancing animal heat-loss capacities, those involving genetic selection of animals for heat tolerance, and those related to modification of feeding strategies and feed composition. Under heat stress, improved production should be possible through modifications of diet composition that either promotes a higher intake or compensates the low feed consumption (Renaudeau et al., 2012).

Most decision support tools for the nutrition of pigs, such as InraPorc®, do not consider the effect of climate on nutrient utilization and voluntary feed intake. Many studies have been conducted in the recent years to evaluate the effects of hot or tropical climates on pig performance. In this context the aim of this task in AnimalChange Project was to build a model representing the effect of a hot climate on heat production and nutrient partitioning in pigs with the final objective to implement this model in the available InraPorc® decision support tool. This is an essential step to develop new feeding strategies (e.g. definition of nutrient content, choice of adapted feed ingredients...) better adapted to more extreme or changing climates and new pig genotypes.

In this deliverable we describe the model and the basis for the decision support tool developed for adapting pig feeding strategies to heat stress.

2. Objective of the decision support tool

As illustrated in figure 1 the general objectives of the decision support tool are (i) to predict growth and lactation performance according to outdoor temperature and animal potential in the thermoneutral zone (ii) to determine the amount of nutrient (amino acids, minerals...) required to achieve these performances. This tool may be used to adapt feeding strategies on medium term according to expected outdoor or indoor temperature (eg according to the location of the farm or the season). For the future, it could also be used in the perspective of precision farming and precision feeding (Pomar et al., 2012) with the objective of real-time adaptation of feed allowance and composition according to real-time measurement of housing conditions.

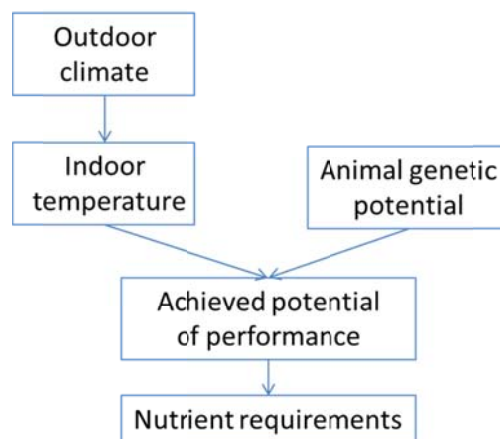

Figure 1. General objectives of the decision support tool

3. Description of the model

The decision support tool is based on the development of a model predicting feed intake and the use of energy and nutrients by pigs according to ambient temperature. This model is organized in three main components:

- a component for the prediction of the temperature perceived by the animal according to outdoor temperature and housing,
- a component for the prediction of the effect of ambient temperature on feed intake and performance,
- a component for the determination of energy and nutrient utilization and requirements.

In the present version the model is developed using the [Vensim©](#) modeling platform. This is a deterministic model. The time step for modeling is the minute for the prediction of housing conditions (this short time step is required for modeling fan control) and the day for nutrient use.

3.1. Prediction of the indoor climate from the outdoor climate

The first component of the model predicts the indoor temperature from outdoor temperature and different characteristics of housing. This is illustrated in figure 2 which represents the Vensim© graphic representation of the model. The outdoor temperature is obtained from a data file with temperature given on an hourly basis. The enthalpy of the room is calculated considering sensible heat production from the animal, heating (for farrowing rooms), heat loss through the floor, the walls and the ceiling, and heat loss through ventilation. Ventilation rate varies between a minimum and a maximum rate (input data) according to indoor temperature and the set point temperature for ventilation. Heating varies between 0 and maximum power according to indoor temperature and a set point temperature for heating. A module to consider the effect of different cooling strategies is also planned but not yet implemented.

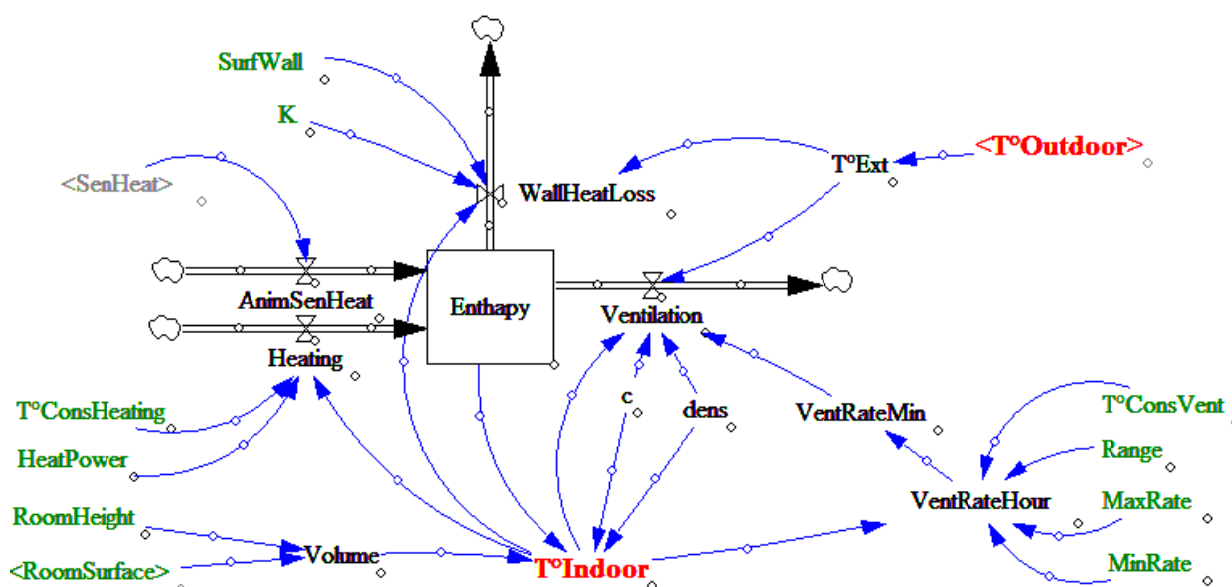

Figure 2. Description of the model component predicting the indoor temperature according to outdoor temperature (in red: input/output data = outdoor and indoor temperature; in green: input variables describing the housing of the pigs; the ventilation and the heating/cooling; in black: intermediate variables).

For growing pigs total heat production is calculated according to feed intake, body weight, and net (NE) and metabolizable energy (ME) content of feed (Figure 3, Rigolot et al., 2010). For lactating sows calculation of heat production also considers the amount of milk produced and the heat produced by the piglets which is determined from litter weight gain (ADG_{litter}) (Rigolot et al., 2010).

$$\text{HeatProd}_{\text{Fattening}} = 750 \text{ BW}^{0.60} + (1 - \text{NE}/\text{ME}) \times \text{ME} \times \text{Feed}$$

$$\text{HeatProd}_{\text{Sow}} = 326 \text{ BW}^{0.75} + (1 - \text{NE}/\text{ME}) \times \text{ME} \times \text{Feed}$$

$$\text{HeatProd}_{\text{Litter}} = (284 + 6.44 \times \text{ADG}_{\text{Litter}}) \times 86.4$$

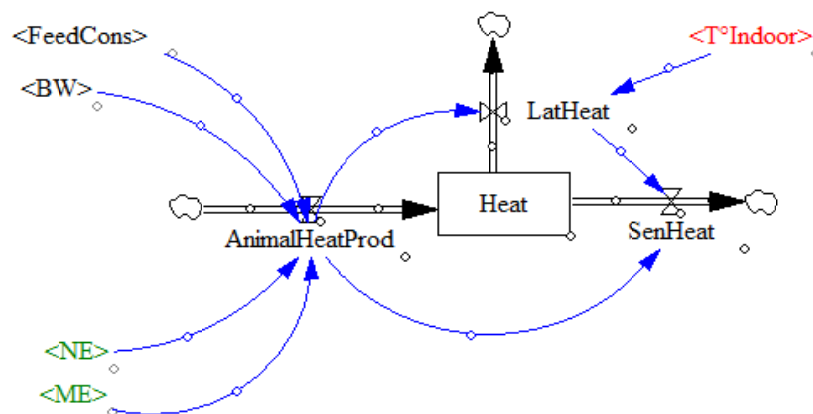

Figure 3. Model of calculation of total, sensible and latent heat production from animals (in red: indoor temperature; in green: input variables describing feed energy content; in black: intermediate variables).

Animal heat production is partitioned between sensible and latent heat according to CGIR (1984).

$$\text{HeatSens} = \text{HeatProd} - \text{HeatProd} \times (0.22 + 1.85 \times 10^{-7} \times (T^{\circ} + 10)^4)$$

3.2. Prediction of the effect of temperature on feed intake and animal performance from a meta-analysis of literature

The prediction of effect of ambient temperature on feed intake is a key issue in the model since this is the starting point in the modeling of nutrient use. An extensive meta-analysis of the literature has been performed within the project on both growing pigs (Renaudeau et al., 2011) and lactating sows (Dourmad et al., in preparation). The equations obtained in these meta-analyses are used in the model to predict the effect of temperature on feed intake. These equations are used to calculate a ratio between feed intake at a given temperature and feed intake at 22°C. This ratio is then multiplied by an input reference value for feed intake at 22°C which is a characteristic of the considered genotype (model input).

The following equations are used for estimating feed intake (FI) of fattening pigs (Renaudeau et al., 2011) and lactating sows (Dourmad et al., in preparation). They are illustrated in figure 4 for different BW, in case of fattening pigs, and parities, in case of lactating sows.

$$\text{FI "fattening"} \text{ (g/d)} = -1331 + 134 \times T - 2.40 \times T^2 + 58.7 \times \text{BW} - 0.105 \times \text{BW}^2 - 0.923 \times T \times \text{BW}$$

$$\text{FI "lactation"} \text{ (g/d)} = 10700 - 465 \times T + 5.69 \times T^2 + 6.29 \times \text{ME}$$

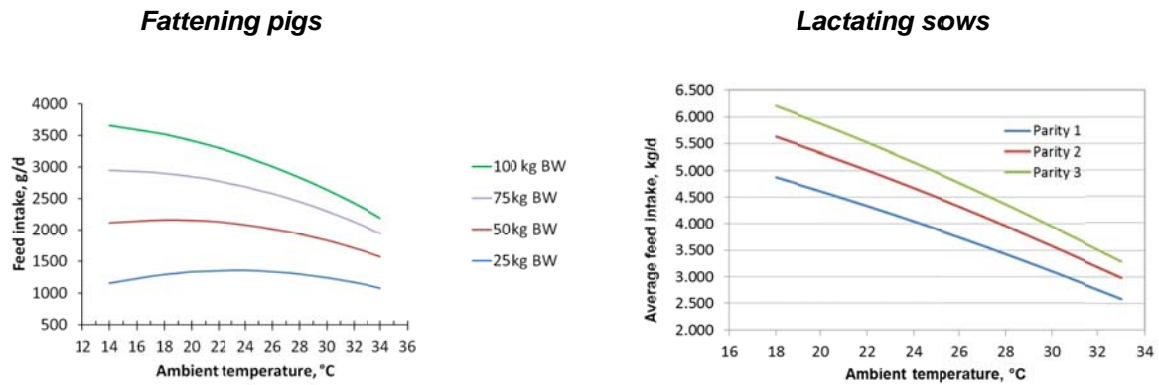

Figure 4. Effect of ambient temperature on feed intake of fattening pigs (Renaudeau et al., 2011) and lactating sows (Dourmad et al., in preparation).

3.3. Nutrient use and prediction of performance and requirements

The description of nutrient use is mainly based on InraPorc© model. A detailed description of this model is given by van Milgen et al. (2008) for growing pigs and Dourmad et al. (2008) for sows. The main compartments and flows of nutrient have been adapted as illustrated in figure 5.

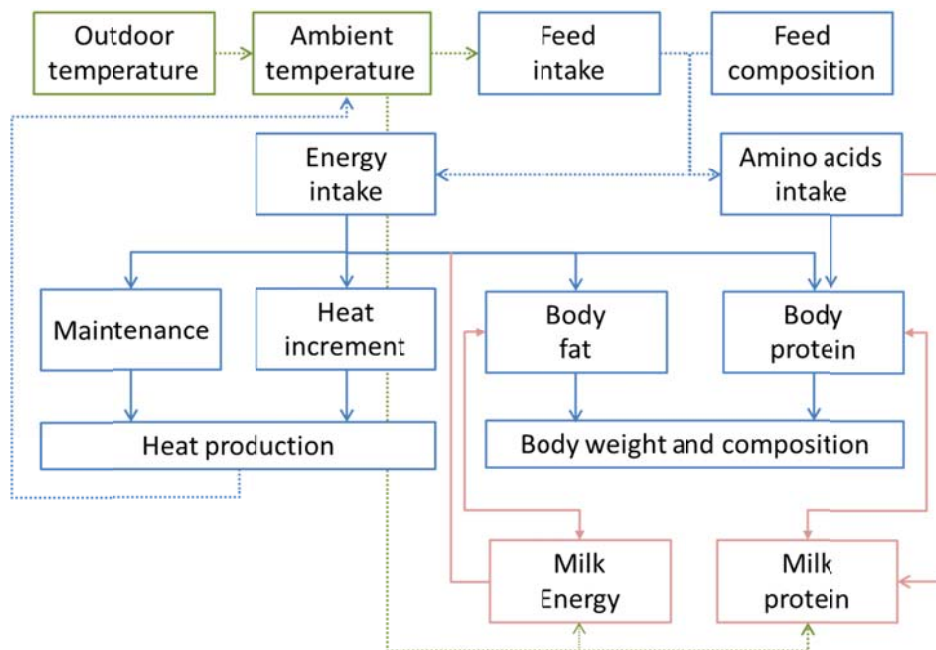

Figure 5. General description of the model of nutrient and energy utilization (adapted from van Milgen et al., 2008, and Dourmad et al., 2008).

The animal is represented as two main body compartments (*ie* body fat and body protein) which are used to predict body weight and body composition according to empirical relationships. The flow of nutrients is represented in terms of flows of metabolizable energy and digestible amino acids. The flow of minerals is also considered but not represented on figure 5.

In the case of growing pigs, energy is partitioned among energy for maintenance (which depends on metabolic body weight), energy for protein deposition (which depends on amino acid supply and animal potential for protein deposition) and heat increment (heat loss associated to fat and protein deposition). Digestible amino acids are used for protein deposition (and maintenance, not represented on figure 5), the excess protein being excreted as urea. In the case of lactating sows the same body compartments and flows of nutrient and energy are also represented, with additional flows for milk energy and fat production.

A detailed description of the Vensim© model for the prediction of energy utilization by lactating sows is given in figure 6. Metabolizable energy (ME) intake is calculated from feed intake which depends on indoor temperature and feed energy content (MEfeed). ME intake is partitioned among ME for maintenance, ME for milk and ME for body reserves, which is generally negative because of insufficient feed intake. ME for body reserves and nitrogen balance (calculated from N in milk and digestible amino acids) are then used for the determination of changes in body fat, body energy and body protein, as described in figure 6. These data are used for the prediction of body weight and body composition (backfat).

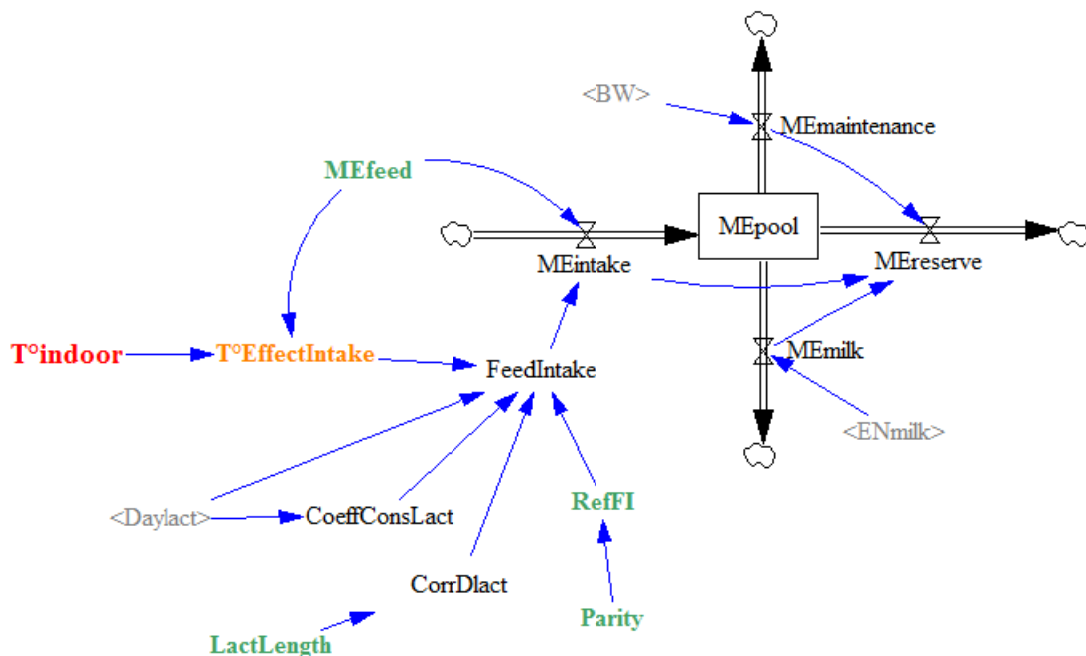

Figure 6. Description of the model for metabolizable energy utilization in lactating sows. (in red: indoor temperature; in green : input variables describing feed and animal characteristics; in orange: effect of ambient temperature derived from the meta-analysis; in black: intermediate variables)

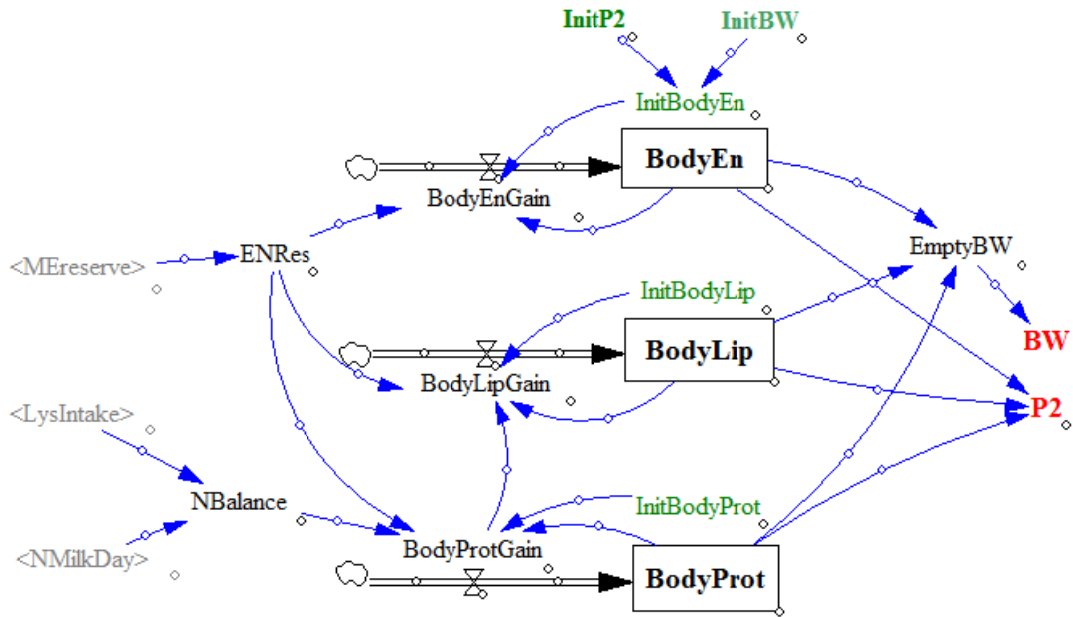

Figure 7. Description of the model of prediction of bodyweight and body composition (backfat depth) in lactating sows. (in red: BW and P2 backfat the predicted variables; in green: input variables describing animal characteristics; in black: intermediate variables).

Daily digestible amino acid requirements are calculated according to protein retention for fattening pigs and protein in milk for lactating sows according to the method described in InraPorc© model. The requirement per kg feed is then obtained by dividing this value by feed intake, as described in figure 7 for lactating sow.

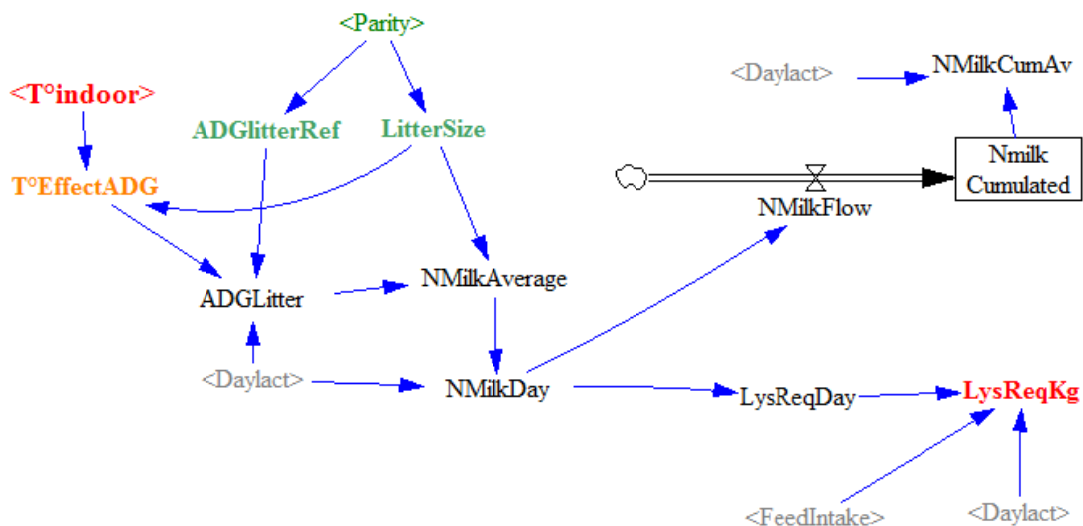

Figure 8. Description of the model for the calculation of digestible lysine requirement in lactating sows. (in red: input/indoor temperature, output/digestible lysine requirement; in green: inputs describing animal characteristics; in black: intermediate variables)

4. Simulation results

Different simulations have been performed in lactating sows and growing pigs to illustrate how the model can be used.

4.1. Example of simulations in growing pigs

The model was used to simulate the evolution of performance and requirements of fattening pigs over one year period, with temperature for year 2001 in Toulouse. Four batches of fattening pigs with similar animal potential were simulated to evaluate the effect of season on performance and amino-acid requirement.

The average performances of the four batches of fattening pigs are presented in table 1. As expected, the average temperatures indoor and outdoor vary with the season (figure 9) with about 4.4 °C differences in average indoor temperature between summer and winter. The simulated feed intake is reduced by about 8% during summer compared to winter (1.93 vs 2.17 kg/d), with intermediate values for spring and autumn. The difference for feed intake between the simulations with and without considering the effect of temperature in the model is the lowest for winter and autumn (-1%) and the highest for summer (-12%). This difference in feed intake affects average daily gain which is reduced in spring and summer.

Table 1. Simulation of performance of four batches of fattening pigs over one year (year 2008 with temperature for Toulouse region). Comparison of the results from modeling with and without the effect of ambient temperature.

	Winter	Spring	Summer	Autumn
Average daily T° (°C)				
Outdoor	8.1	13.7	21.9	10.6
Indoor	22.1	23.2	26.5	22.7
Average daily gain (g/d)				
Model	838	821	762	834
Reference	847	848	848	848
<i>Difference (% of Ref)</i>	-1.1%	-3.3%	-10.1%	-1.6%
Average slaughter weight (kg)				
Model	106.3	104.5	99.2	106.2
Reference	107.1	106.9	106.7	107.4
<i>Difference (% of Ref)</i>	-0.8%	-2.3%	-7.0%	-1.1%
Feed consumption (kg/d)				
Model	2.17	2.12	1.93	2.16
Reference	2.20	2.20	2.20	2.20
<i>Difference (% of Ref)</i>	-1.3%	-3.7%	-12.2%	-2.0%
Feed conversion rate, kg/kg				
Model	2.59	2.58	2.53	2.59
Reference	2.59	2.60	2.59	2.60
<i>Difference (% of Ref)</i>	-0.15%	-0.47%	-2.36%	-0.38%

The effect of season on amino acid requirement is presented in figure 8 for digestible lysine. The requirement is expressed as a percentage of the requirement calculated by InraPorc without considering the effect of temperature. For winter and autumn the difference is rather small (less than 1%) whereas during summer the requirement is increased up to 4% in the finishing period.

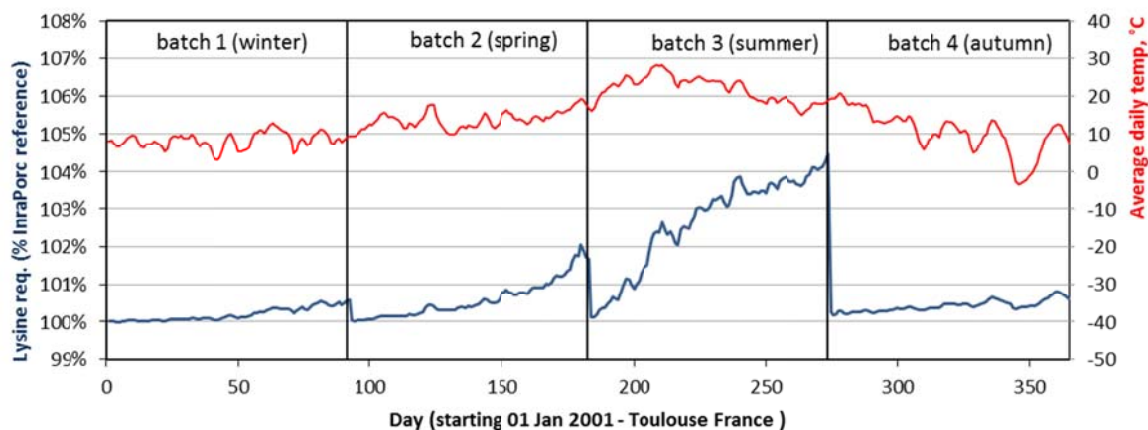

Figure 9. Evolution of digestible lysine requirement of four successive batches of pigs, expressed as a percentage of reference value calculated.

4.2. Example of simulations in lactating sows

The model was used to simulate the evolution of performance and requirements of lactating sows over one year period, with temperature for year 2001 in Toulouse. Twelve batches of lactating sows with similar animal potential, either primiparous or multiparous were simulated to evaluate the effect of season on performance and amino-acid requirement. The results are presented in table 2 per season.

Table 2. Simulation of performance of 10 batches of lactating sows over four seasons (year 2008 with temperature for Toulouse region), comparison of the results for primiparous and multiparous sows.

	Winter	Spring	Summer	Autumn
Indoor temperature (°C)	22.8	23.6	26.8	24.5
Litter ADG (g/d)				
Primiparous	2654	2621	2473	2578
Multiparous	2904	2872	2724	2828
Feed Intake (kg/d)				
Primiparous	4.96	4.89	4.65	4.82
Multiparous	6.26	6.17	5.87	6.08
Digestible Lysine (g/kg)				
Primiparous	10.2	10.3	10.9	10.5
Multiparous	8.6	8.8	9.2	8.9

As expected, the average temperatures indoor and outdoor vary with the season with about 4°C differences in average indoor temperature between summer and winter (26.8 vs 22.8 °C). Compared to winter, average litter growth rate is reduced in winter by 6.8% and 6.2% in primiparous and multiparous sows, respectively, and daily feed intake by 310 and 390 g, respectively.

The evolution of digestible lysine requirement per kg feed is presented in figure 10. The requirement is higher in primiparous than in multiparous sows (10,5 versus 8,9 g/kg, respectively) and increases during summer, especially in July and August, by about 8% compared to winter season (figure 10).

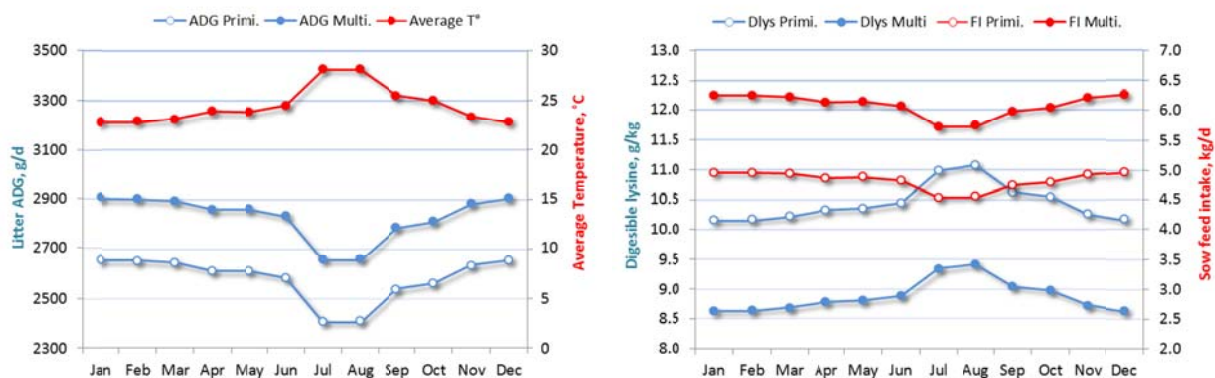

Figure 10. Evolution over the year of litter weight gain, and sow feed intake and digestible lysine requirement of 10 successive batches of primiparous or multiparous lactating sows.

5. Conclusion and perspectives

This decision support tool has been developed using Vensim© modeling platform. This offers the possibility to evaluate the effect of different climatic situations in combination with different feeding strategies and animal profiles. The input data required for the simulation may be entered in an Excel© file. However, the interface may still be improved. The strategy will be to take benefit of the InraPorc platform, which offers a friendly interface for the description of animal potential feed composition and feeding strategy, and the formatting of results in tables and graphs.

6. Literature cited

Dourmad, J. Y., Etienne, M., Valancogne, A., Dubois, S., Van Milgen, J., Noblet, J. 2008. InraPorc: a model and decision support tool for the nutrition of sows. Anim. Feed Sci. Technol. 143, 372-386.

Renaudeau D., Gourdine J. L., St-Pierre N. R., 2011. A meta-analysis of the effects of high ambient temperature on growth performance of growing-finishing pigs. *J. Anim. Sci*, 89, 2220-2230.

Renaudeau D., Collin A., Yahava S., de Basillio V., Gourdine J. L., Collier R. J., 2012. Adaptation to hot climate and strategies to alleviate heat stress in livestock production. *Animal*, 6, 707-728.

Rigolot C., Espagnol S., Pomar C., Dourmad J-Y. 2010. Modeling of manure production by pigs and NH₃, N₂O and CH₄ emissions. Part I: animal excretion and enteric CH₄, effect of feeding and performance. *Animal*, 4, 1401-1412.

van Milgen, J., Valancogne, A., Dubois, S., Dourmad, J.Y., Sève B., Noblet, J., 2008. InraPorc: a model and decision support tool for the nutrition of growing pigs. *Anim. Feed Sci. Technol.* 143, 387-405.