



HAL
open science

Capillary rheometry of a binary mixture polymer/CO₂ in a single screw extruder

Audrey Common, Martial Sauceau, Élisabeth Rodier, Jean-jacques
Letourneau, Jacques Fages

► **To cite this version:**

Audrey Common, Martial Sauceau, Élisabeth Rodier, Jean-jacques Letourneau, Jacques Fages. Capillary rheometry of a binary mixture polymer/CO₂ in a single screw extruder. *Chemical Engineering and Processing: Process Intensification*, 2015, 93, pp.21-26. 10.1016/j.cep.2015.04.004 . hal-01611093

HAL Id: hal-01611093

<https://hal.science/hal-01611093>

Submitted on 9 Jan 2018

HAL is a multi-disciplinary open access archive for the deposit and dissemination of scientific research documents, whether they are published or not. The documents may come from teaching and research institutions in France or abroad, or from public or private research centers.

L'archive ouverte pluridisciplinaire **HAL**, est destinée au dépôt et à la diffusion de documents scientifiques de niveau recherche, publiés ou non, émanant des établissements d'enseignement et de recherche français ou étrangers, des laboratoires publics ou privés.

Capillary rheometry of a binary mixture polymer/CO₂ in a single screw extruder

Audrey Common¹, Martial Sauceau, Elisabeth Rodier, Jean-Jacques Letourneau, Jacques Fages*

Université de Toulouse, Ecole des Mines d'Albi, CNRS, Centre RAPSODEE, 81013 Albi, France

ABSTRACT

Processing bio sourced polymers with supercritical fluids is a promising route towards new green engineering processes. Supercritical carbon dioxide (sc CO₂), is soluble in large quantities in molten polymers, where it acts as plasticizer and swelling agent. It is used, in blending or foaming of polymers, particle formation and polymerisation process.

The process of hot melt extrusion assisted by sc CO₂ allowed the development of an on line viscosity measurement based on capillary rheometry. Applied to a bio sourced polyamide, it was validated by comparison with a classic capillary rheometer. Both data sets were in good agreement.

A pseudoplastic fluid behaviour was observed with a 30 % viscosity decrease from 46 to 32 Pa.s at 5000 s⁻¹ and 220 °C, upon addition of CO₂. However, viscosity decreased to a plateau before reaching the thermodynamic solubility. The comparison with a model coupling solubility and flow allowed to identify the method limitations, which were attributed to the kinetics of dissolution and mixing. The higher the shear stress, the higher the amount of CO₂ at which the viscosity plateau is reached. These measurements may quantify the impact of the CO₂ on the rheology of the system but also of the efficiency of the mixing process in our experimental setup.

Keywords:

Hot-melt extrusion
Supercritical carbon dioxide
Capillary rheometry
Polymer viscosity

1. Introduction

Most of the polymers used in industry nowadays have a petrochemical origin. However, due to the predicted exhaustion of the world petroleum reserves, it is necessary to replace them with bio sourced polymers with equivalent properties. It is also important to find new ways of processing them, which comply with the requirements of green chemistry. The use of supercritical fluids in polymer processing has considerably grown up in the last decades [1–3]. The most used is supercritical carbon dioxide (sc CO₂). It is soluble in large quantities in many molten polymers and can be added in extrusion processes where it acts as a plasticizer and swelling agent [4]. It is known to be a green processing agent of great interest in the polymer field, such as blending of polymers, polymer foaming, particle formation or polymerization process.

Extrusion is a process converting a raw material into a product of uniform shape and density by forcing it through a die under

controlled conditions [5]. It has extensively been applied in the plastic and rubber industries, where it is the most important manufacturing process.

Coupling sc CO₂ and extrusion modifies the rheological properties of the polymer while flowing through the barrel of the extruder [5]. The reduction of viscosity decreases the mechanical constraints and the operating temperature within the extruder. Thus, this may allow the use of fragile or thermolabile molecules, like active pharmaceutical ingredients. Furthermore, the absence of residues in the final material is also an advantage for pharmaceutical applications [6,7].

Using a new sc CO₂ assisted extrusion process, microcellular foams of a biocompatible amorphous polymer were elaborated [8]. However, understanding and improving such a process requires the knowledge of physical properties, like the solubility of CO₂ into the polymer, the diffusion coefficient and the viscosity of the mixture. An extruder provides a high shear rate, particularly in the die. However, the viscosity of the binary system under process conditions is very difficult to reach in conventional rheometers. Viscosity under pressure can be measured in different ways [9]. One group of measurements is based on vibrating surface or falling ball rheometers [10]. These techniques require Newtonian or low viscosity polymers. The other main group of measurement

* Corresponding author at: Ecole des Mines d'Albi, Campus Jarlard, F-81013 Albi, France. Tel.: +33 563 493 141; fax: +33 563 493 025
E-mail address: Jacques.Fages@mines-albi.fr (J. Fages).

¹ Present address: Separex, 5 Rue Jacques Monod, 54250 Champigneulle, France.

techniques is based on capillary rheometry. This technique is widely used for viscous polymers and implementations exist to measure the rheology of mixtures of polymer and sc CO₂ [11].

In this work, we have implemented this on line technique on a single screw extruder in order to estimate the viscosity of a bio sourced semi crystalline polymer. Firstly, the validity of the method will be checked by comparing the obtained results with measurements made on a classic capillary rheometer. Secondly, we will apply this technique to the binary system polymer/carbon dioxide. Finally, the comparison with a flow model will be implemented to identify some limitations of the technique.

2. Theory of capillary rheometry

The principle of capillary rheometry is to force melt polymer through a die of length L and diameter D . Knowing the volume flow rate Q and the pressure loss ΔP ($P - P_{atm}$) created by the die, the shear rate $\dot{\gamma}_{app}$, the stress τ_p and subsequently the viscosity η can be calculated (Fig. 1). To determine this viscosity, several assumptions need to be made. A Poiseuille flow in a tube is assumed with the following additional hypotheses:

- incompressible fluid with a laminar, isothermal and established flow,
- no end effects,
- no wall slip.

If these hypotheses are verified, then the following formulas apply:

$$\tau_p = \frac{D\Delta P}{4L} \quad (1)$$

$$\dot{\gamma}_{app} = \frac{32Q}{\pi D^3} \quad (2)$$

$$\eta = \frac{\tau_p}{\dot{\gamma}_{app}} \quad (3)$$

For non newtonian fluids, the Rabinowitch correction should apply:

$$\dot{\gamma}_w = \dot{\gamma}_{app} \left(\frac{3m+1}{4m} \right) \text{ with } m = \frac{d \ln \tau_p}{d \ln Q} \quad (4)$$

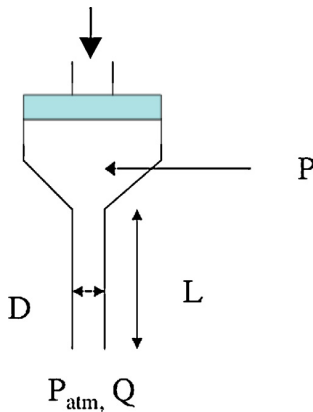

Fig. 1. Principle of a capillary rheometer under pressure.

Another arguable hypothesis is the absence of end effects, which may require corrections. One way is to use a long die in order to make the effects negligible. The other method is to implement the Bagley correction [12]. It consists in carrying out measurements with dies of different lengths and to use the slope of $\Delta P - f(L/D)$ to calculate τ_p . The problem of this method is the high number of experiments required.

3. Materials and methods

Polyamide PA 11, commercial name Rilsan[®] (BMFO grade, Arkema, France), is a bio sourced polymer amino 11 undecanoic acid obtained from castor oil. It is a linear polymer with a number average molar mass of 8700 g mol⁻¹ and a weight average molar mass of 20,010 g mol⁻¹.

Melting onset temperature of the PA 11 is in the range 180–200 °C and the glass transition temperature within 40–60 °C. The solid density ρ_B , determined by helium pycnometry (Micromeritics, AccuPyc 1330) was 1027 ± 5 kg m⁻³. Melt density was found to be 979 kg m⁻³ at 220 °C with a magnetic suspension balance (Rubotherm, Germany).

Solubility measurements of CO₂ in the polymer were carried out on the same magnetic suspension balance at 202, 220 and 231 °C at different pressures.

The experimental set up (Fig. 2) has previously been used with several polymers including PA 11 [13–16]. The single screw extruder has a 30 mm screw diameter and a length to diameter ratio (L/D) of 35 (Rheoscam, SCAMEX, France). A great L/D ratio generally indicates a good capacity of mixing and melting but an important energy consumption. The screw is divided into three parts. The first one has a length to diameter ratio of 20 while the others have a length to diameter ratio of 7.5. Between each part, a restriction ring has been fitted out in order to obtain a dynamic gastight, which prevents sc CO₂ from back flowing. The first conical part allows the transport of solid polymers and then, their melting and plasticizing. Then, the screw has a cylindrical geometry from the first gastight ring to the die. The temperature inside the barrel is regulated at five locations: T_a and T_b before the CO₂ injection, T_c and T_d after the injection and T_e in the die. All temperatures were set at 220 °C.

There are three pressure and two temperature sensors: P_1 after the CO₂ injector, P_2 and T_1 before the second gastight ring and P_3 and T_2 by the die. This allows measuring the temperature and the pressure of the polymer inside the extruder. Errors associated to pressure and temperature measurements were about 0.2 MPa and 1 °C, respectively.

Three dies have been used. They all have a diameter of 1 mm and their lengths are 7, 17 and 22 mm. Those dies will be called here L7, L17 and L22, respectively.

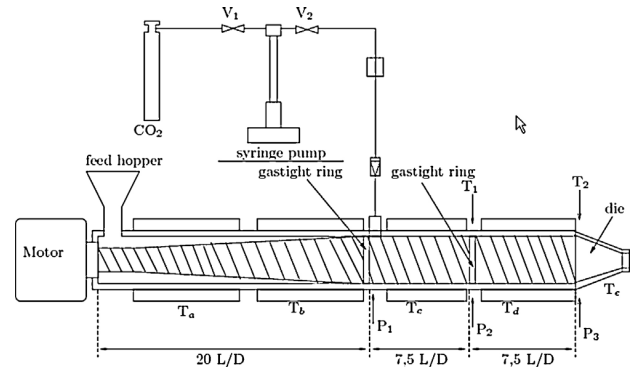

Fig. 2. Experimental device.

CO₂ (N45, Air Liquide, France) is pumped from a cylinder by a syringe pump (260D, ISCO, USA) and then introduced at constant volumetric flow rate at a length to diameter ratio of 20 from the feed hopper. The pressure in the CO₂ pump is kept slightly higher than the pressure P_1 . The pressure, the temperature and the volumetric CO₂ flow rate are measured within the syringe pump. CO₂ density, obtained on NIST website by Span and Wagner equation of state [17,18], is used to calculate mass flow rate and thus the CO₂ mass fraction w_{CO_2} . CO₂ flow rate was varied and its influence on the viscosity of the mixture was studied. Once steady state conditions (tested on P and T measurements) are reached, mass flow rate and pressure (P_3) are measured.

For the implementation of the theory of capillary rheometry, the melt density has been considered as independent of the pressure, and taken equal to the value measured by a magnetic suspension balance at 220 °C and atmospheric pressure. Moreover, in the case of CO₂ injection, we have stated that the hypothesis of incompressible fluid and constant density is acceptable since the solubilisation of less than 5 % of dense CO₂ (density of which is 400 kg m⁻³) with an increase in volume of the same order of magnitude will result in a density variation of about 2–3%.

Parallel measurements on a capillary rheometer (CR) (Instron model 3211, USA) were made at the Laboratoire des Matériaux Polymères et des Biomatériaux (ISTIL EPUL, Lyon, France). This rheometer is equipped with a piston of 0.9525 cm² and with a force sensor of 20 kN with a precision of 0.2%. One die of L/D 140 (L 70 mm and D 0.5 mm) is used. Measurements were carried out at 220 °C.

4. Results

4.1. Comparison of both methods

Measurements on the extruder were carried out with the three dies (Table 1). Experiments were compared with results obtained on the Instron capillary rheometer. At first, end effects could be postulated as negligible with the longest die L22 and only the Rabinowitch correction was applied ($m = 0.56$). Nevertheless, Bagley correction was also implemented on the extruder experiments in order to evaluate end effects. Experimental results obtained with the three dies were interpolated at the same shear rate, which allows plotting the Bagley curves (Fig. 3). According to the procedure of analysis described hereafter, the pressure drop is reported on the x axis, whereas the capillary aspect ratio is reported on the y axis. The non linear shape of these curves is commonly attributed to the effect of the pressure on the viscosity [19].

To estimate the effect of pressure on viscosity, Pantani and Sorrentino have proposed the following expression for the Bagley curves [20]:

$$\frac{L}{D} = \alpha \Delta P^2 + b \Delta P + c \quad (5)$$

Table 1

Data obtained on the extruder with the three different dies.

L7		L17		L22	
ΔP (MPa)	Q (cm ³ s ⁻¹)	ΔP (MPa)	Q (cm ³ s ⁻¹)	ΔP (MPa)	Q (cm ³ s ⁻¹)
5.8	0.50	8.3	0.22	14.5	0.31
7.6	0.65	10.3	0.35	18.0	0.45
9	0.82	12.5	0.50	20.0	0.58
10	1.01	14.9	0.65	23.0	0.71
11	1.20	17.7	0.82	25.5	0.86
11.6	1.38	18.2	0.97	28.0	1.00
		19	1.14		

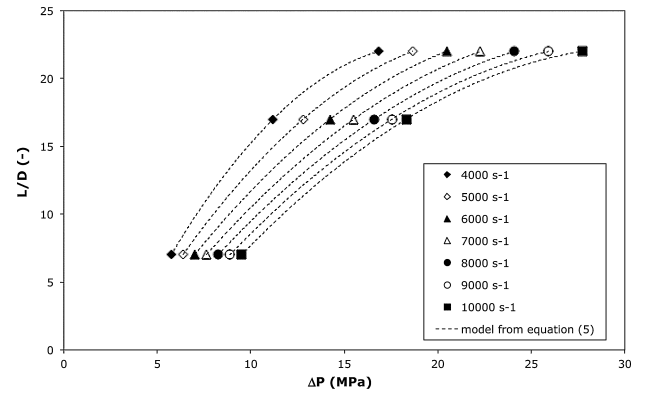

Fig. 3. Bagley curves calculated at different shear rates.

with

$$\begin{cases} \tau_{\text{op}} = \frac{1}{4b} \\ \frac{e}{D} = c \\ \beta = \frac{2a}{b} \end{cases} \quad (6)$$

τ_{op} is the stress at zero entrance pressure, e an additional length which takes into account the entrance effect on pressure drop and β a parameter describing the pressure effect on viscosity in the Barus law. As can be seen in Fig. 3, the data were well represented by Eq. (5). The β values obtained decreased from $55 \times 10^{-9} \text{ Pa}^{-1}$ at 4000 s^{-1} to $35 \times 10^{-9} \text{ Pa}^{-1}$ at 10000 s^{-1} (Fig. 4). These values are coherent with the ones reported at an average temperature of 210 °C for polypropylene (PP) and polystyrene (PS), but higher than those obtained for PA66 found to be around $7 \times 10^{-9} \text{ Pa}^{-1}$ at temperatures below 300 °C [21]. Finally, the entrance pressure drops were extrapolated from Fig. 3, allowing to calculate the corrected stresses. After the application of the Rabinowitch correction ($m = 0.54$), the corrected viscosity can be calculated.

Fig. 5 shows the comparison of results obtained on the extruder and on the capillary rheometer. Both series of results are in good agreement. However, results on the extruder treated with the Bagley correction give significantly lower viscosity values. Therefore, the correction seems to be useful for this die. The set of viscosity values obtained with the commercial rheometer are higher.

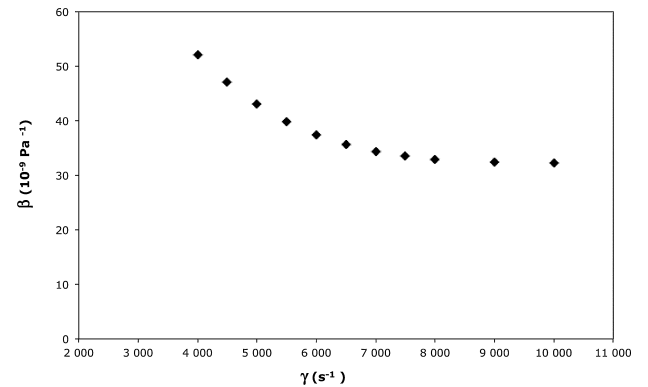

Fig. 4. Evolution of the Barus coefficient.

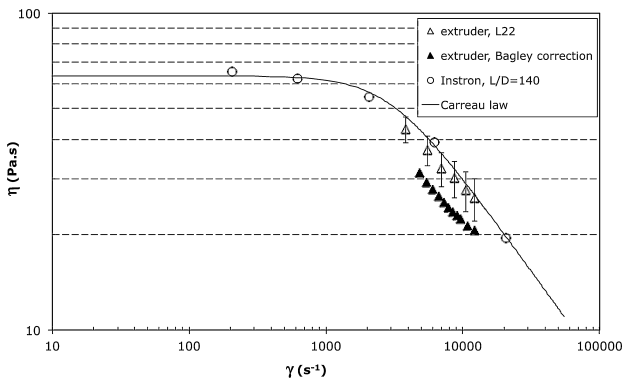

Fig. 5. Comparison of different rheological results.

This discrepancy might be ascribed to:

- temperature control during the experiment. Both methods used temperature set at 220 °C but the heating takes place through a static polymer in the CR during around 1 h whereas there is mixing in the extruder with short residence times (around 3 min).
- pressure level is quite different. Pressure in the CR is in the range 6 200 MPa and particularly within 60 200 MPa, which corresponds to the range of shear rates encountered in the die of the extruder. This high level of pressure may induce an increase in viscosity. Pressure level in the extruder is between 7 and 25 MPa.
- sample storage leading to a possible change in the moisture content. PA 11 is quite sensitive to humidity.

In order to further investigate these discrepancies and to use this comparison as a validation of the method, we could use a less sensitive polymer and evaluate pressure corrections to the CR results. Nevertheless, untreated results still give a good order of magnitude of the viscosity.

4.2. Evolution of viscosity of the mixture

Experiments on the binary system were carried out on the extruder only with the L22 die, which ensures a good pressure for solubilisation of CO₂ in the extruder and minimizes the number of experiments. However, it has to be kept in mind that even though the quantitative value is not exact, due to the lack of correction, the qualitative evolution is correct.

Solubility experimental data were represented by a Sanchez Lacombe equation of state [22,23] by using the expression of the fugacity coefficients of a component in the mixture proposed by Neau [24]. The pure characteristic parameters of each component were taken as indicated in Table 2. Moreover, the following mixing rules were used, endowed with one fitted binary parameter for the characteristic energy ϵ^* :

Table 2
Pure characteristic parameters for Sanchez–Lacombe equation of state.

Compounds	ρ^* (g/cm ³)	T^* (K)	P^* (MPa)
PA 11 [25]	1.035	765.0	465.4
CO ₂ ^a	1.2518	354.1	329.3

^aCalculated by using data obtained on NIST website by Span and Wagner equation of state [17,18].

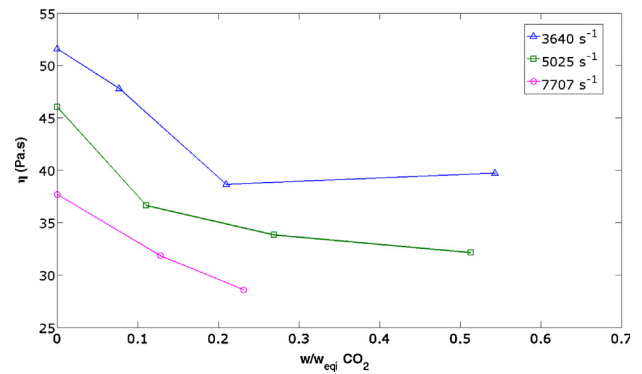

Fig. 6. Evolution of the binary system viscosity as a function of CO₂ content and shear rate.

$$\epsilon^* = \sum_i \sum_j \phi_i \phi_j \epsilon_{ij}^* \text{ with } \epsilon_{ij}^* = (1 - k_{ij})(\epsilon_i^* \epsilon_j^*)^{0.5} \quad (7)$$

This model was then used to evaluate the solubility (w_{eq}) at each point of the die. Solubility at the die entrance is noted w_{eqi} .

Viscosity of the binary system decreases with the increase in CO₂ content and shear rate (Fig. 6). The behaviour in terms of shear rate is not surprising since polymers are often shear thinning. The decrease in viscosity related to CO₂ addition is also consistent with literature observations. This decrease usually follows a power law [26]. However, our measurements suggest a plateau, which is not consistent with such a law. This may be due to the desorption of the CO₂ in the die and the occurrence of a two phase system that could disturb measurements.

In fact, an important issue with binary mixture is to know if the system is in a single phase. Multiple pressure sensors along the die would be necessary to check this assumption [27]. However, our system was set with only one sensor at the entrance of the die. Thus, an evaluation of the exact location of desorption in the die was made. A linear depressurisation was assumed from the entrance to the exit [28]. This linear depressurisation was confirmed by modelling the die flow with Comsol Multiphysics[®] by using Navier Stokes equations for an incompressible fluid. A Carreau law (Fig. 5) was used to represent the viscosity η of the polymer (Table 3):

Table 3
Parameters for the Carreau law.

η_0 (Pa s)	η_∞ (Pa s)	λ (s)	n (-)	a (-)
63.46	0	3.40×10^{-4}	0.40	2

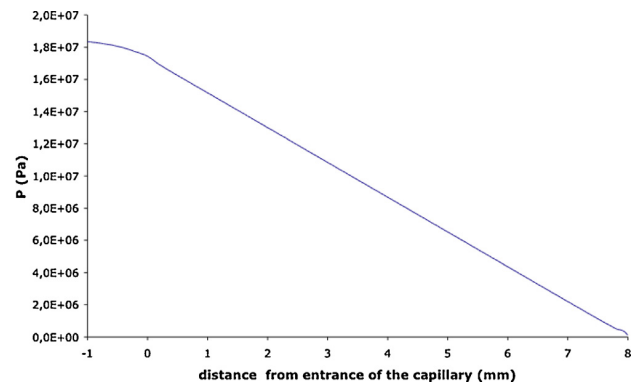

Fig. 7. Profile of pressure along the die.

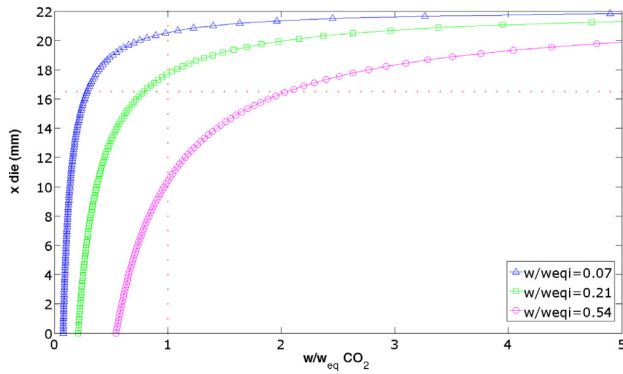

Fig. 8. Desorption point at 3640 s⁻¹ at 3 different initial ratios.

$$\eta = \eta_{\infty} + (\eta_0 - \eta_{\infty}) \left[1 + (\lambda \dot{\gamma})^a \right]^{(n-1)/a} \quad (8)$$

η_0 is the viscosity at zero shear rate, η_{∞} the viscosity at infinite shear rate, λ the relaxation time, n the power index and a a dimensionless parameter describing the transition between the first Newtonian plateau and the power law region.

An example of the results found by the flow simulation is presented on Fig. 7. Figs. 8–10 show the location of the point of desorption for each experimental measurement at the three shear rates studied and for different CO₂ contents. Desorption is assumed to occur when $w = w_{eq}$.

As the CO₂ content increases, desorption occurs earlier in the die. When desorption occurs within the first three quarters of the die length (16.5 mm), viscosity measurements differ from the power law, as shown by the logarithmic chart in Fig. 11. The index

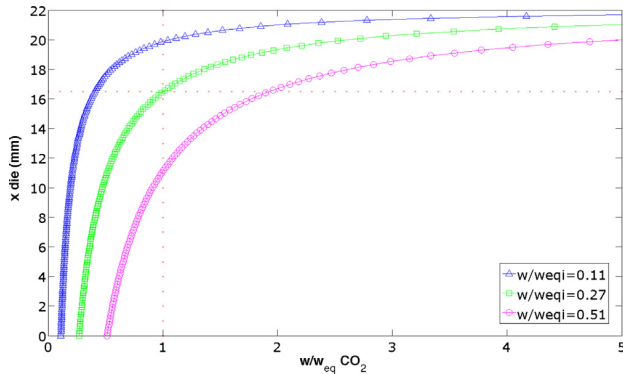

Fig. 9. Desorption point at 5025 s⁻¹ at 3 different initial ratios.

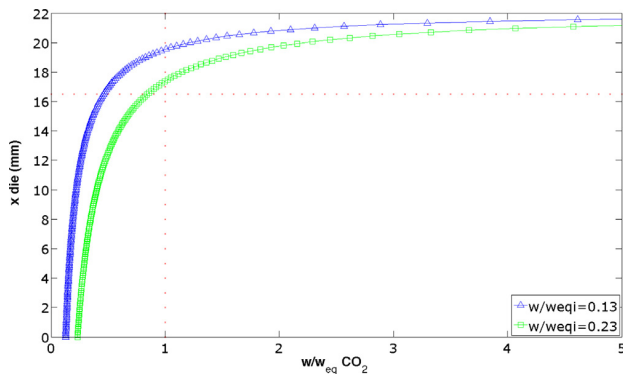

Fig. 10. Desorption point at 7707 s⁻¹ at 2 different initial ratios.

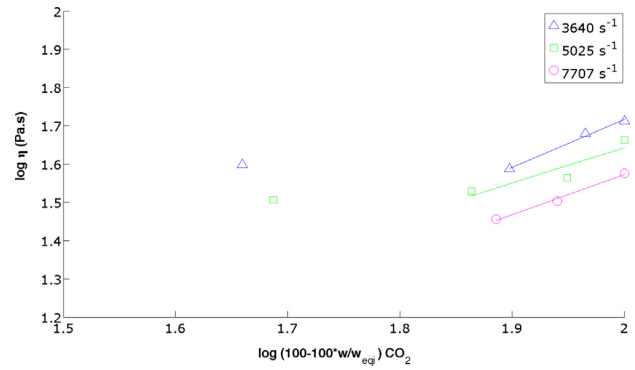

Fig. 11. Logarithmic chart of the evolution of viscosity of the binary as a function of CO₂ content and shear rate.

Table 4
Index of the power law.

$\dot{\gamma}$ (s ⁻¹)	3640	5025	7707
n (–)	1.25	0.92	1.05

of the power law, n , for the three shear rates are listed in Table 4. Viscosity results can thus be assumed accurate as long as the CO₂ content is not too high and desorption does not occur too early in the die. In this study, the limit appears to be $w/w_{eqi} < 0.27$.

Finally, a decrease of the viscosity around 25% is observed in the single phase criterion region defined above ($w/w_{eqi} < 0.27$, corresponding to a mass percentage up to 2% of CO₂). The appearance of the plateau at higher CO₂ content is due to the predominance of the two phase occurrence along the die. The viscosity measured in this zone can be seen as an apparent viscosity of the mixture in the process. It reflects coupling of flowing with physical phenomena of two phase occurrence. Then, it can be used to apprehend phenomenological behaviour of the flowing mixture in the process.

5. Conclusion

Capillary rheometry is an efficient method to measure viscosity of polymer at high shear rate. We implemented this technique on line on an extruder in order to carry out measurement in processing conditions. Validity of the measurements was checked with a commercial capillary rheometer. Measurements on the binary mixture CO₂/polymer were then carried out. Desorption point along the die was located by means of a solubility model (Sanchez Lacombe) coupled with a flow model and correlated with experimental data. A minimal distance before CO₂ desorption must be attained to ensure accuracy of the data. Those experiments and calculation demonstrate the efficiency of capillary rheometry to measure viscosity of polymer and binary system polymer/sc CO₂. The set up with only one pressure sensor at the entrance of the die works at low ratio of CO₂. Above a given CO₂ content, depending on the solubility, pressure and length of the die, depressurisation occurs too early in the die and measurements give access to apparent viscosity in process conditions. To access absolute viscosity of the mixture, a system with multiple pressure sensors would be necessary.

Acknowledgements

This paper is dedicated to the memory of our esteemed colleague Elisabeth Rodier who left us much too early.

This work was made possible thanks to financial support of the ANR (French National Agency for Research) and to Arkema company that supplied the polymer.

Authors would like to thank Pr. Jean Pierre Puaux from LMPB (Lyon, France) laboratory who kindly accept to carry out experiments on his capillary rheometer. The technical support of Olivier Ezequel is also gratefully acknowledged.

References

- [1] R.B. Yoganathan, R. Mammucari, N.R. Foster, Dense gas processing of polymers, *Polym. Rev.* 50 (2) (2010) 144–177.
- [2] H.P. Zhang, M.C. Chen, Polymerization in supercritical carbon dioxide, *Prog. Chem.* 21 (9) (2009) 1869–1879.
- [3] E. Reverchon, R. Adami, S. Cardea, G. Della Porta, Supercritical fluids processing of polymers for pharmaceutical and medical applications, *J. Supercrit. Fluids* 47 (3) (2009) 484–492.
- [4] M. Saucéau, J. Fages, A. Common, C. Nikitine, E. Rodier, New challenges in polymer foaming: a review of extrusion processes assisted by supercritical carbon dioxide, *Prog. Polym. Sci.* 36 (6) (2011) 749–766.
- [5] C. Rauwendaal, *Polymer Extrusion*, Hanser Publishers, München, 2001.
- [6] Z.K. Nagy, M. Saucéau, K. Nyúl, E. Rodier, B. Vajna, G. Marosi, J. Fages, Use of supercritical CO₂ aided and conventional melt extrusion for enhancing the dissolution rate of an active pharmaceutical ingredient, *Polym. Adv. Technol.* 23 (2012) 909–918.
- [7] T. Vigh, M. Saucéau, J. Fages, E. Rodier, I. Wagner, P.L. Solti, G. Marosi, Z. Nagy, Effect of supercritical CO₂ plasticization on the degradation and residual crystallinity of melt-extruded spirinolactone – non-invasive testing of immediate-release solid dispersions, *Polym. Adv. Technol.* 25 (2014) 1135–1144.
- [8] C. Nikitine, E. Rodier, M. Saucéau, J.-J. Letourneau, J. Fages, Controlling the structure of a porous polymer by coupling supercritical CO₂ and single screw extrusion process, *J. Appl. Polym. Sci.* 115 (2) (2010) 981–990.
- [9] A. Shine, *Polymers and supercritical fluids*, *Phys. Prop. Polym. Handb.* 18 (2007) 319.
- [10] B. Calvignac, E. Rodier, J.-J. Letourneau, P. Vitoux, C. Aymonier, J. Fages, Development of an improved falling ball viscometer for high-pressure measurements with supercritical CO₂, *J. Supercrit. Fluids* 55 (1) (2010) 96–106.
- [11] M. Nobelen, S. Hoppe, C. Fonteix, F. Pla, M. Dupire, B. Jacques, Modeling of the rheological behavior of polyethylene/supercritical CO₂ solutions, *Chem. Eng. Sci.* 61 (2006) 5334–5345.
- [12] E. Bagley, End corrections in the capillary flow of polyethylene, *J. Appl. Phys.* 28 (5) (1957) 624–627.
- [13] M. Saucéau, C. Nikitine, E. Rodier, J. Fages, Effect of supercritical carbon dioxide on polystyrene extrusion, *J. Supercrit. Fluids* 43 (2007) 367–373.
- [14] C. Nikitine, E. Rodier, M. Saucéau, J. Fages, Residence time distribution of a pharmaceutical grade polymer melt in a single screw extrusion process, *Chem. Eng. Res. Des.* 87 (6) (2009) 809–816.
- [15] C. Nikitine, E. Rodier, M. Saucéau, J.-J. Letourneau, J. Fages, Controlling the structure of a porous polymer by coupling supercritical CO₂ and single screw extrusion process, *J. Appl. Polym. Sci.* 115 (2010) 981–990.
- [16] A. Common, E. Rodier, M. Saucéau, J. Fages, Flow and mixing efficiency characterisation in a CO₂-assisted single-screw extrusion process by residence time distribution using Raman spectroscopy, *Chem. Eng. Res. Des.* 92 (2014) 1210–1218.
- [17] Carbon dioxide, NIST Chemistry WebBook, <http://webbook.nist.gov/cgi/cbook.cgi?ID=124-38-9>.
- [18] R. Span, W. Wagner, A new equation of state for carbon dioxide covering the fluid region from the triple-point temperature to 1100 K at pressures up to 800 MPa, *J. Phys. Chem. Ref. Data* 25 (6) (1996) 1509–1596.
- [19] H. Laun, Polymer melt rheology with a slit die, *Rheol. Acta* 22 (2) (1983) 1435–1528.
- [20] R. Pantani, A. Sorrentino, Pressure effect on viscosity for atactic and syndiotactic polystyrene, *Polym. Bull.* 5 (4–5) (2005) 365–376.
- [21] S. Ceccia, C. Cocquet, L. Trouillet-Fonti, D.R. Long, Influence of pressure on polyamide 66 shear viscosity: a case study towards polar polymers behavior, *Rheol. Acta* 53 (2014) 181–190.
- [22] I.C. Sanchez, R.H. Lacombe, An elementary molecular theory of classical fluids. Pure fluids, *J. Phys. Chem.* 80 (21) (1976) 2352–2362.
- [23] I.C. Sanchez, R.H. Lacombe, Statistical thermodynamics of polymer solutions, *Macromolecules* 11 (6) (1978) 1145–1156.
- [24] E. Neau, A consistent method for phase equilibrium calculation using the Sanchez–Lacombe lattice-fluid equation-of-state, *Fluid Phase Equilib.* 2 (2002) 133–140.
- [25] P.A. Rodgers, Pressure–volume–temperature relationships for poly(vinylidene fluoride) and polyamide-11, *J. Appl. Polym. Sci.* 50 (12) (1993) 2075–2083.
- [26] J.R. Royer, Y. Gay, J.M. Desimone, S.A. Khan, High pressure rheology of polystyrene melts plasticized with CO₂: experimental measurement and predictive scaling relationships, *J. Polym. Sci. Part B: Polym. Phys.* 38 (2000) 3168–3180.
- [27] A. Xue, C. Tzoganakis, Rheological properties of polystyrene/supercritical CO₂ solution from an extrusion slit die, *J. Polym. Eng.* 23 (1) (2003) 1–22.
- [28] X. Han, K.W. Koelling, D.L. Tomasko, L.J. Lee, Effect of die temperature on the morphology of microcellular foams, *Polym. Eng. Sci.* 43 (6) (2003) 1206–1220.