



HAL
open science

Les procédés d'agglomération par sollicitations mécaniques. Application à la structuration de la semoule de blé dur pour la fabrication du couscous

Bettina Bellocq, Bernard Cuq, Agnès Duri-Bechemilh, Thierry Ruiz

► To cite this version:

Bettina Bellocq, Bernard Cuq, Agnès Duri-Bechemilh, Thierry Ruiz. Les procédés d'agglomération par sollicitations mécaniques. Application à la structuration de la semoule de blé dur pour la fabrication du couscous. 16. Congrès de la société française de génie des procédés (SFGP 2017), Jul 2017, Nancy, France. hal-01602787

HAL Id: hal-01602787

<https://hal.science/hal-01602787>

Submitted on 2 Jun 2020

HAL is a multi-disciplinary open access archive for the deposit and dissemination of scientific research documents, whether they are published or not. The documents may come from teaching and research institutions in France or abroad, or from public or private research centers.

L'archive ouverte pluridisciplinaire **HAL**, est destinée au dépôt et à la diffusion de documents scientifiques de niveau recherche, publiés ou non, émanant des établissements d'enseignement et de recherche français ou étrangers, des laboratoires publics ou privés.



Distributed under a Creative Commons Attribution - ShareAlike 4.0 International License

LES PROCÉDÉS D'AGGLOMÉRATION PAR SOLLICITATIONS MECANIQUES.

APPLICATION A LA STRUCTURATION DE LA SEMOULE DE BLÉ DUR POUR LA FABRICATION DU COUSCOUS.

Bettina Bellocq

Under the supervision of:

Pr. Bernard CUQ, Dr. Thierry RUIZ and Dr. Agnès DURI

UMR IATE – INRA Montpellier – France

16^{ème} Congrès de la Société Française de Génie des Procédés

Nancy – 12 Juillet 2017

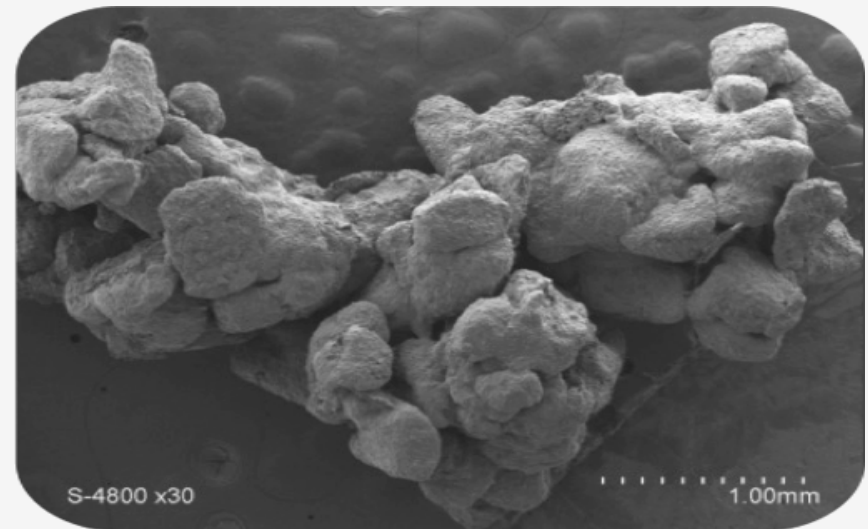



Plan

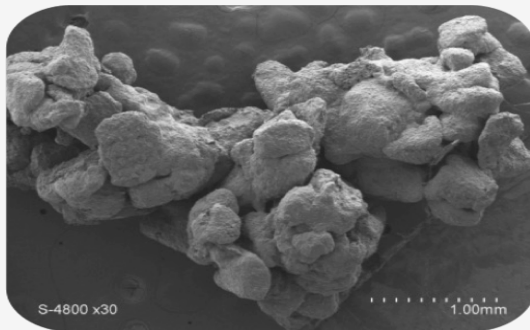

1

INTRODUCTION - WET AGGLOMERATION

2

DURUM WHEAT SEMOLINA AND MIXERS

3

IMPACT OF THE PROCESS

4

HYDROTEXTURAL ANALYSIS

5

CONCLUSION



Plan

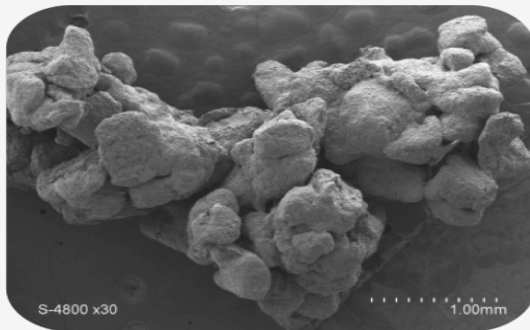

1

INTRODUCTION - WET AGGLOMERATION

2

DURUM WHEAT SEMOLINA AND MIXERS

3

IMPACT OF THE PROCESS

4

HYDROTEXTURAL ANALYSIS

5

CONCLUSION

1.1. WET AGGLOMERATION OF FOOD POWDERS

Agglomeration is largely used to improve the powders **properties and behaviour**:

- *Reduction in dust production.*
- *Enhancement in flowability.*
- *Increase in bulk density.*
- *Reduction in segregation.*

During the agglomeration process...
 ...the **native small particles** are gathered to form **larger assemblies** with specific **porous structures**, called the **agglomerates**.



Agglomerated food powders

- *Cocoa beverage powders*
- *Instant soluble coffee*
- *Culinary powders*
- *Flavors powders*
- *Protein powders*
- *Infant formulas*
- *Couscous grains*
- *Dairy powders*
- *Milk powders*
- *Bakery mixes*
- *Starch*

1.1. WET AGGLOMERATION OF FOOD POWDERS

Agglomeration is largely used to improve the powders **properties and behaviour**:

- *Reduction in dust production.*
- *Enhancement in flowability.*
- *Increase in bulk density.*
- *Reduction in segregation.*

During the agglomeration process...
 ...the **native small particles** are gathered to form **larger assemblies** with specific **porous structures**, called the **agglomerates**.



Agglomerated food powders

- *Cocoa beverage powders*
- *Instant soluble coffee*
- *Culinary powders*
- *Flavors powders*
- *Protein powders*
- *Infant formulas*
- **Couscous grains**
- *Dairy powders*
- *Milk powders*
- *Bakery mixes*
- *Starch*

1.2. WET AGGLOMERATION - PROCESS

During the agglomeration process, a **liquid binder (water)** is sprayed over an **agitated powder bed**.

It generates **attractive interactions** and **links** between the native particles and...

... Promotes the **spatial arrangement of the native particles** with the binder.

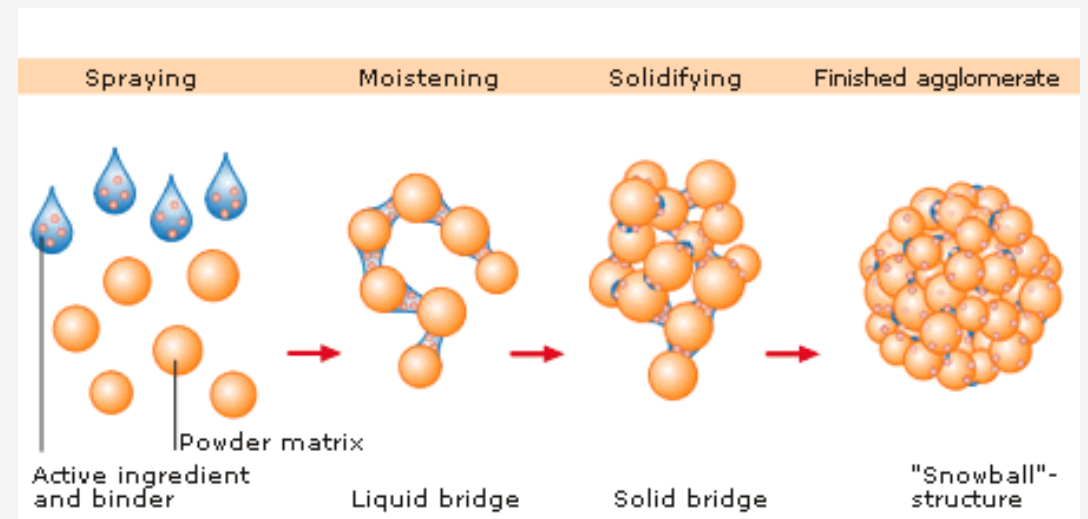
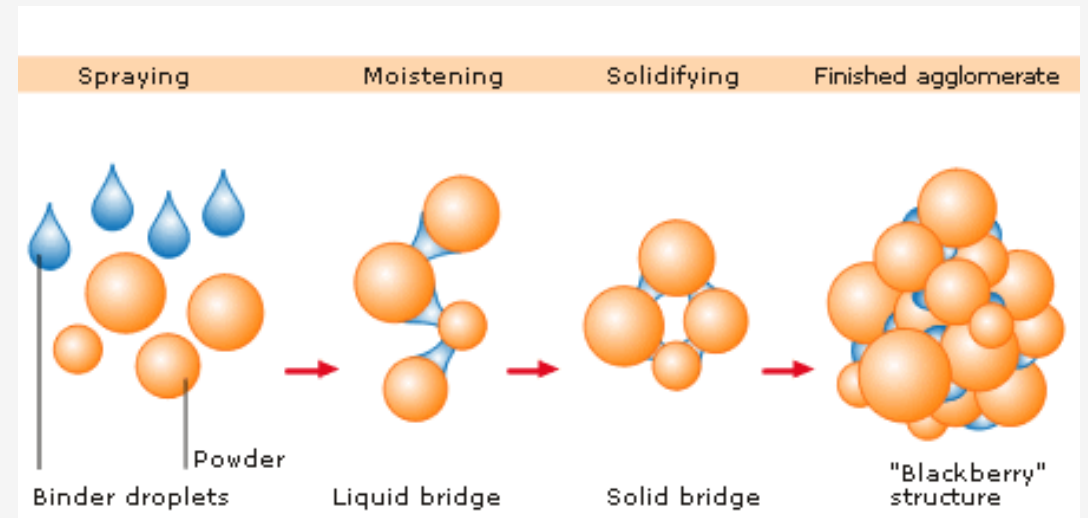

<http://www.cjtech.co.kr/Process%20Principles%20Agglomeration%20Granulation.htm>

1.2. WET AGGLOMERATION - PROCESS

Different technologies have been used for wet agglomeration processes. They can be classified in **two categories** according to the **type of the mixing energy**.

The **pneumatic mixing granulators** (e.g. steam jet, spray drying, or fluid bed) use **air steam to agitate** the particles under low shear conditions.



Ex. Fluidized bed

The **mixing granulators** (e.g. mechanical mixer, pan, disk, or drum granulators) use **mechanical system** to agitate the particles.

Ex. Planetary mixer



The **variability of the raw materials** associated with the **differences between different apparatus** induce a high degree of **complexity in the process**.

1.3. WET AGGLOMERATION - MECHANISMS

Wet agglomeration process is classically described as a combination of successive mechanisms at different rates :

- **Wetting and nucleation.**
- **Growth and consolidation.**
- *Breakage, erosion, rupture*

The **cohesion forces** generate **interactions** between particles, and promote granules **growth**.

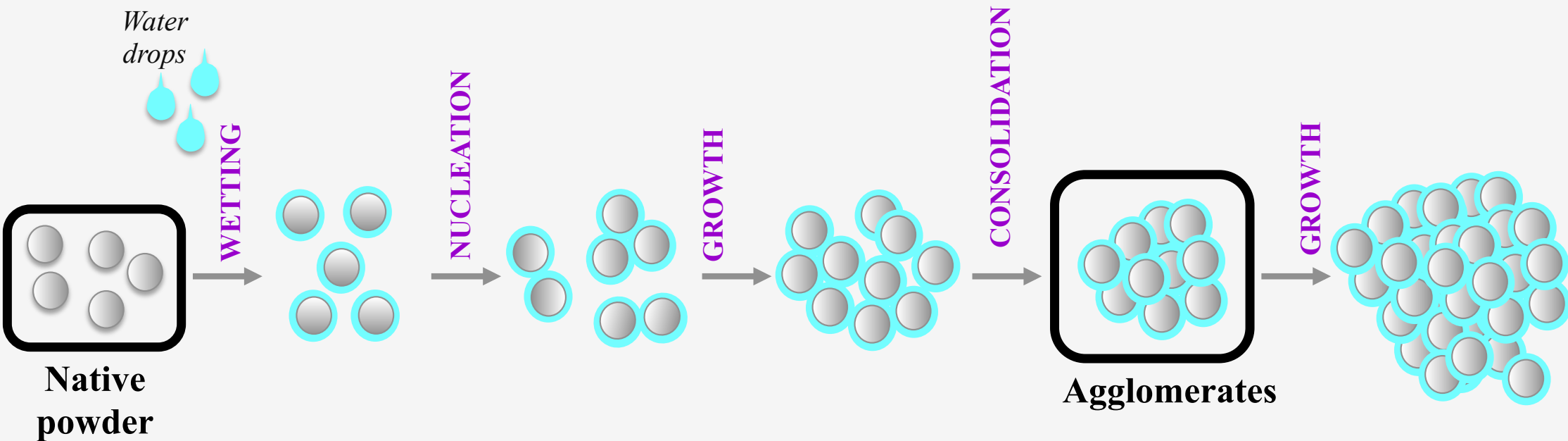

1.3. WET AGGLOMERATION - MECHANISMS

Wet agglomeration process is classically described as a combination of successive mechanisms at different rates :

- *Wetting and nucleation.*
- *Growth and consolidation.*
- **Breakage, erosion, rupture**

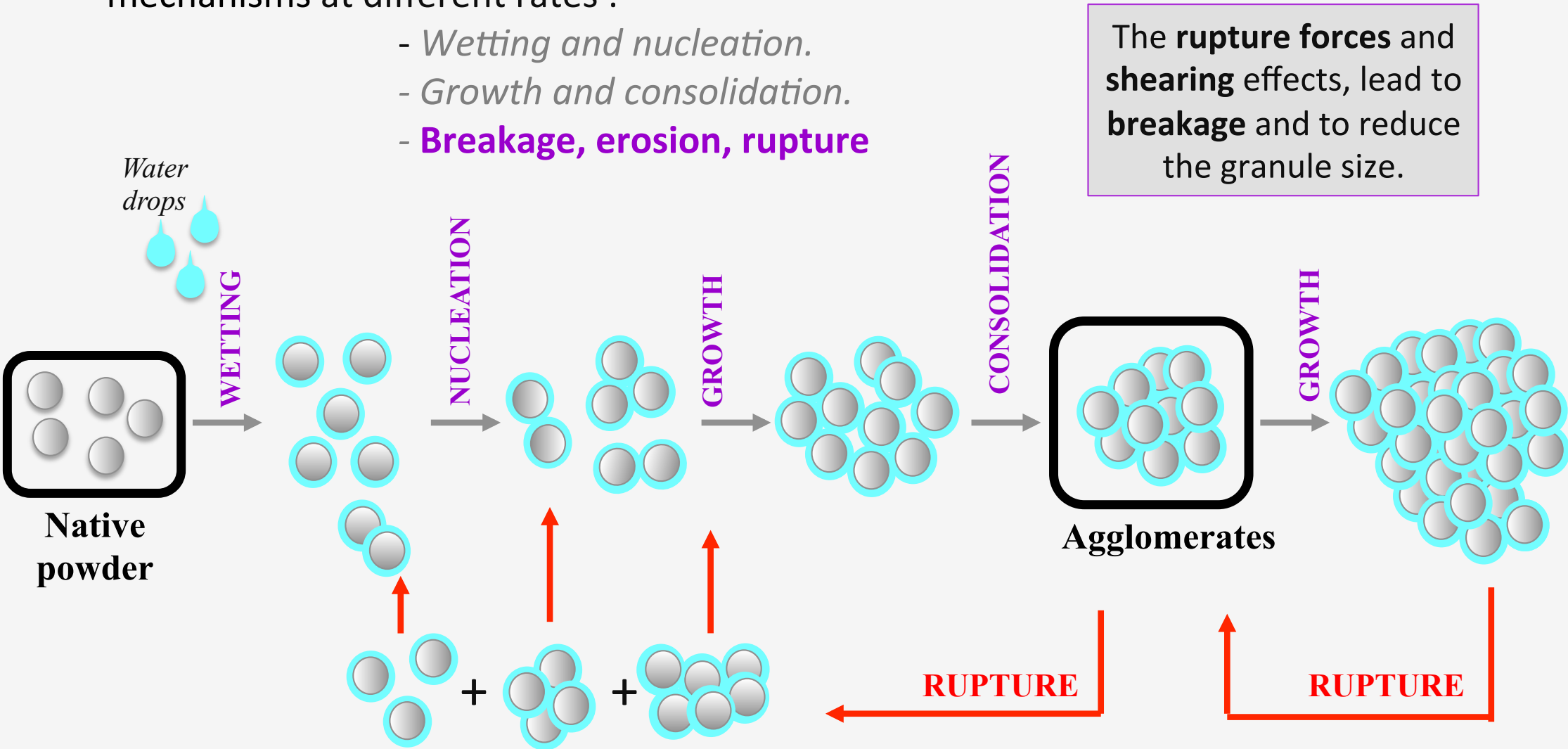

The **rupture forces** and **shearing** effects, lead to **breakage** and to reduce the granule size.

The wet agglomeration process is a **balance** between **growth** and **breakage**

1.4. HYDROTEXTURAL APPROACH

Hydrotextural approach is used to describe agglomeration mechanisms based on changes in **compactness** and **diameter** of the agglomerates as a function to the **water content**.

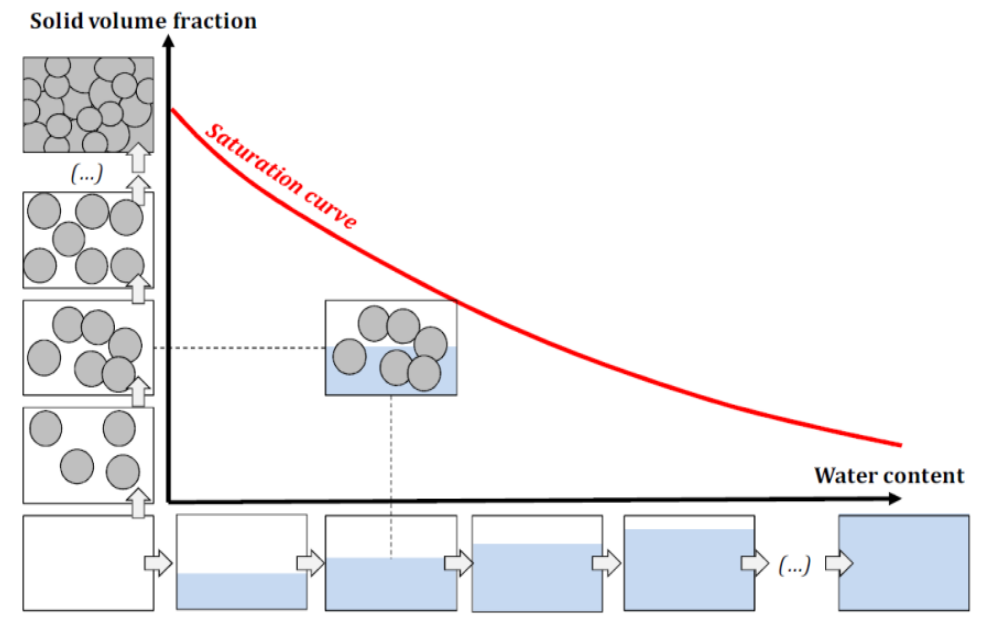

Schema of the hydrotextural diagram (Ruiz et al., 2005)

1.4. HYDROTEXTURAL APPROACH

Hydrotextural approach is used to describe **agglomeration mechanisms** based on changes in **compactness** and **diameter** of the agglomerates as a function to the **water content**.

Hydrotextural diagram is limited by the **saturation curve** until which agglomerates are completely filled by water.

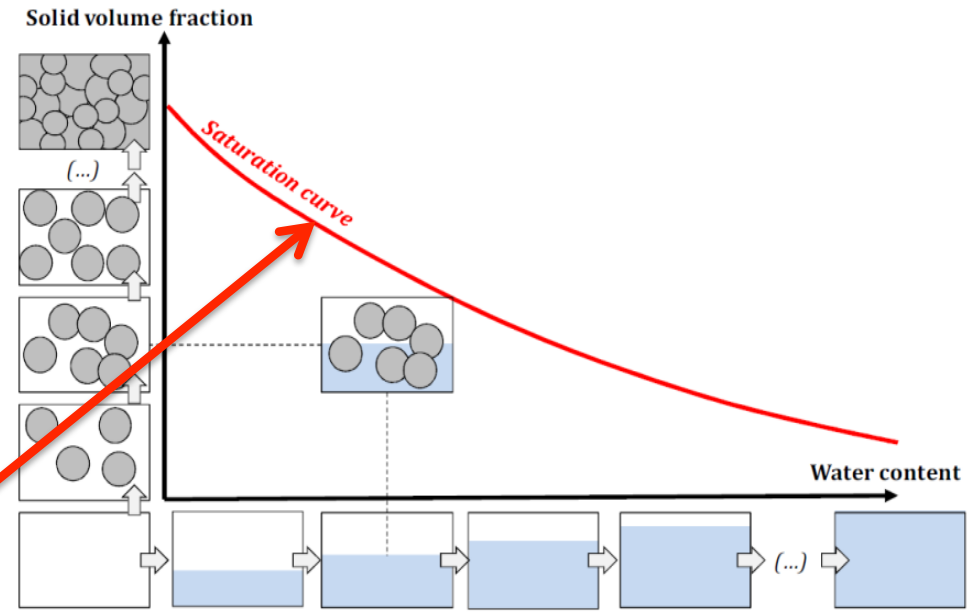

Schema of the hydrotextural diagram (Ruiz et al., 2005)

1.4. HYDROTEXTURAL APPROACH

Hydrotextural approach is used to describe agglomeration mechanisms based on changes in **compactness** and **diameter** of the agglomerates as a function to the **water content**.

Hydrotextural diagram is limited by the **saturation curve** until which agglomerates are completely filled by water.

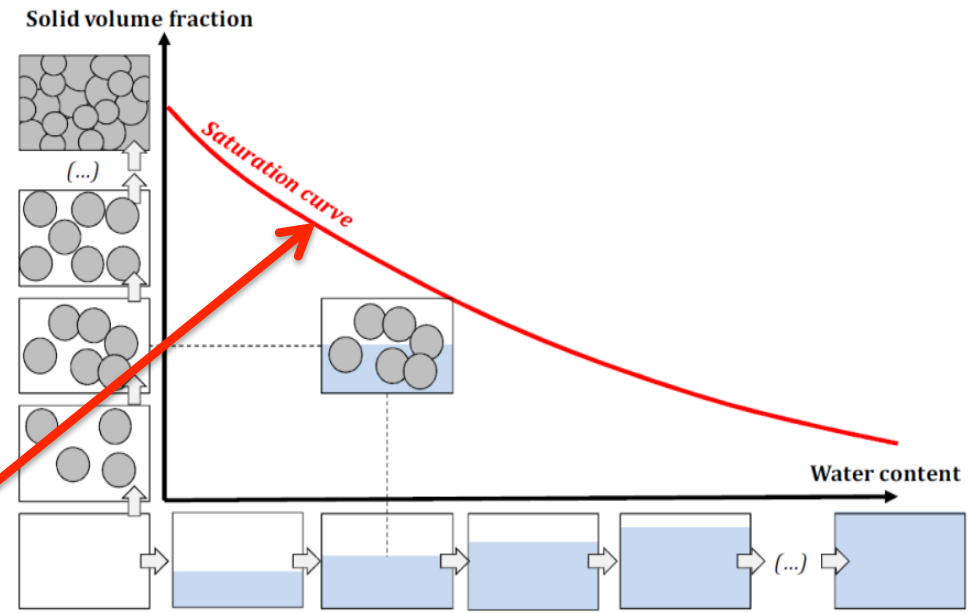

Schema of the hydrotextural diagram (Ruiz et al., 2005)

Agglomerates were analysed by measuring :

Size

= Median diameter

Water content

= $\text{Mass of water} / \text{Mass of dry product}$

Compactness

= $\text{Volume of solid} / \text{Total Volume}$

Saturation degree

= $\text{Volume of liquid} / \text{Volume of void}$

1.5. CASE OF THE COUSCOUS GRAINS

- 3 unit operations.

- Polydispersity of the size cause a high ratio of out of scope (too large >2 mm, or too small <1 mm).

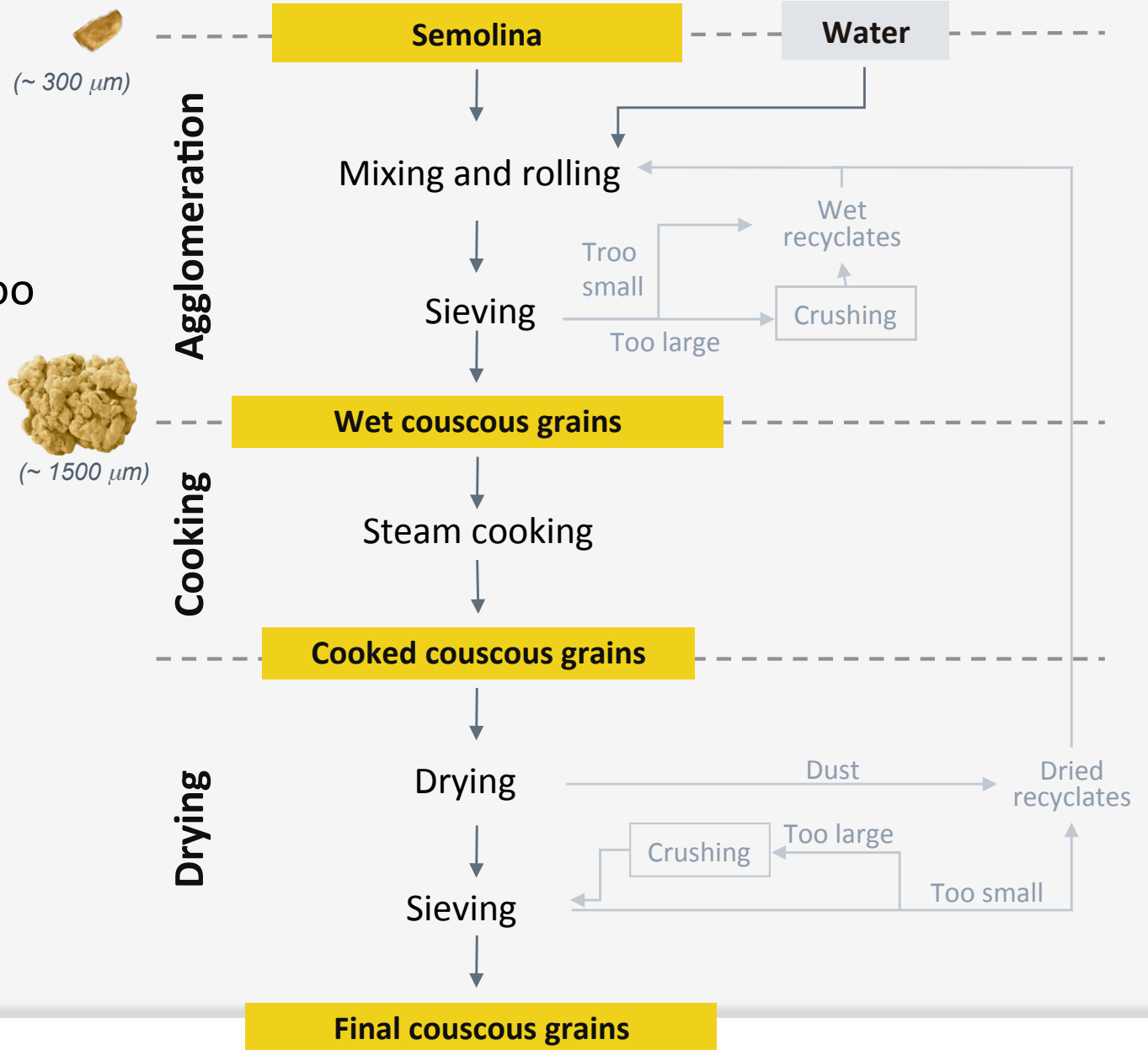

1.5. CASE OF THE COUSCOUS GRAINS

- 3 unit operations.

- Polydispersity of the size cause a high ratio of out of scope (too large >2 mm, or too small <1 mm).

- Agglomeration is a key unit operation to control the size of the couscous grains.

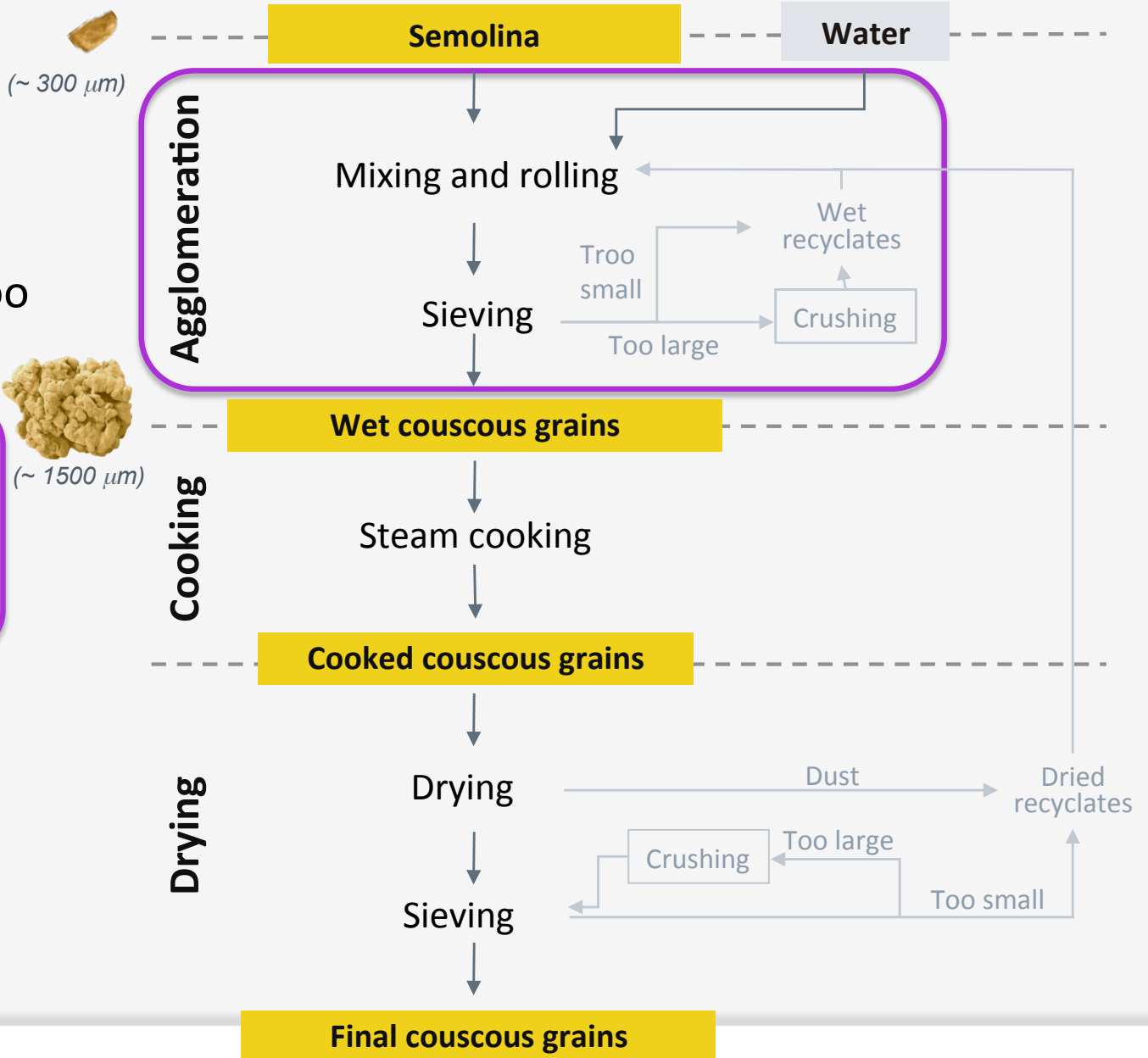

1.6. OBJECTIVES

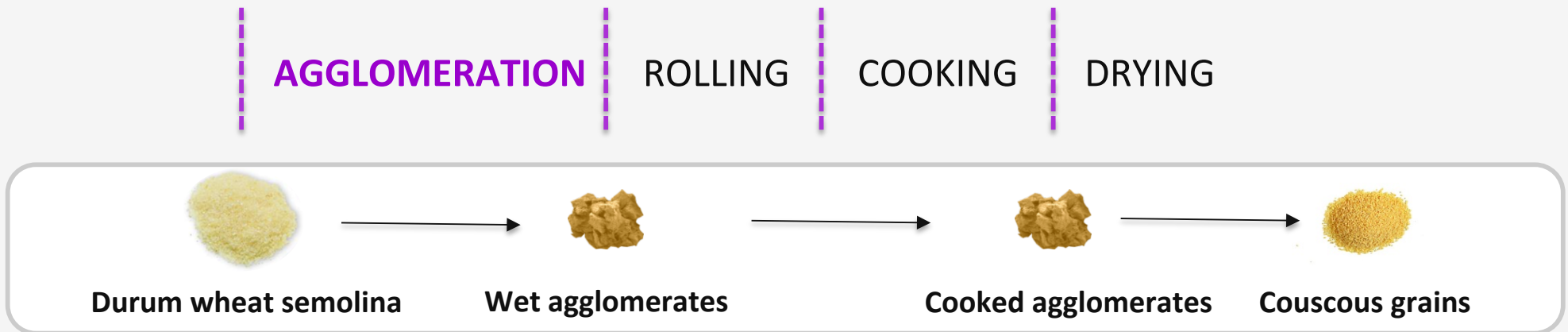
**Our objectives were:**

- To **describe the agglomeration** by analysing experimental investigations.
- To understand how **the process** impact the agglomeration.
- To understand how **the raw material (diameter and protein)** impact the agglomeration.

1.6. OBJECTIVES

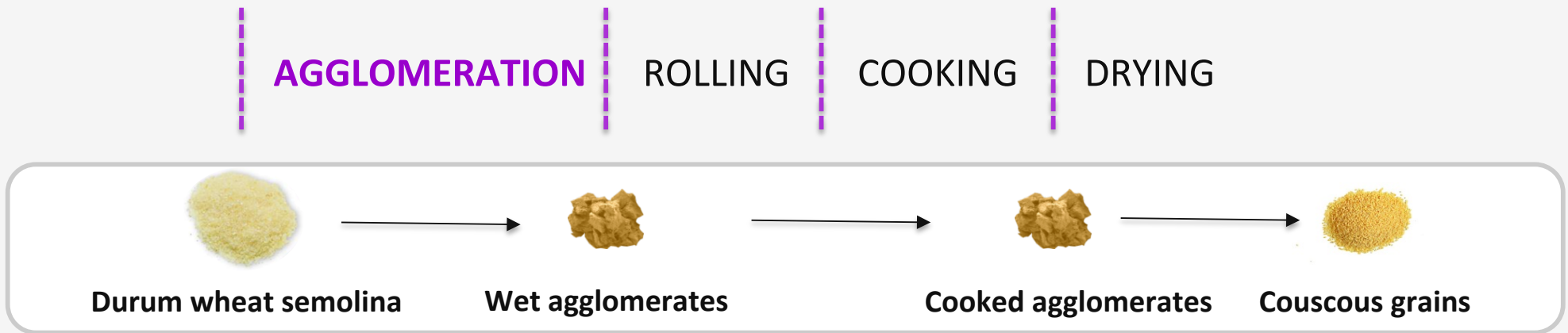

Our objectives were:

- To describe the agglomeration by analysing experimental investigations.
- To understand how **the process** impact the agglomeration.
- To understand how **the raw material (diameter and protein)** impact the agglomeration.



Plan

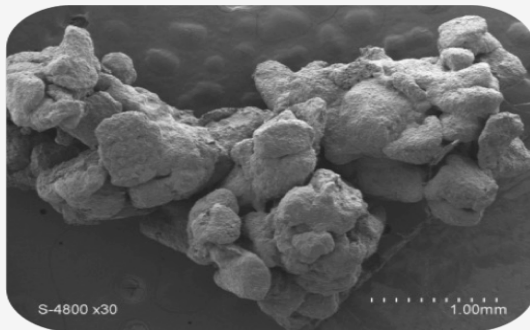

1

INTRODUCTION - WET AGGLOMERATION

2

DURUM WHEAT SEMOLINA AND MIXERS

3

IMPACT OF THE PROCESS

4

HYDROTEXTURAL ANALYSIS

5

CONCLUSION

2.1. RAW MATERIAL

Wheat powder (**durum wheat semolina**)

- **Large** particles ($d_{50} = 287 \mu\text{m}$) with **distribution** of diameters.
- **Dense** native particles (not porous).

Biochemical composition : **starch** (85%), **proteins** (12%), **fibres** (2%), and **lipids** (1%).

- Components are **partly soluble**.

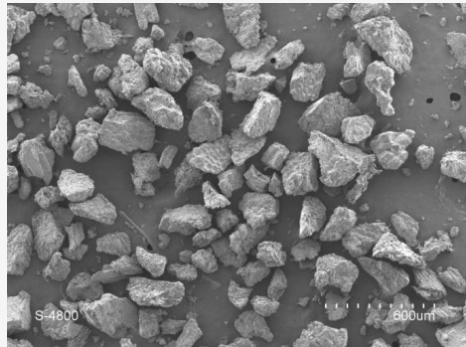

Durum wheat semolina

Characteristics	Values	Method
Water content (%)	16.4 (± 0.5)	Method 44-15A AACC
Protein content (%)	12.4 (± 0.4)	Method 050 (AFNOR)
Particle size median diameter (μm)	287 (± 8)	Laser granulometry
Particle size span (-)	1.56 (± 0.17)	Laser granulometry
True density (g/cm^3)	1.478 (± 0.005)	Helium pycnometry
Plastic limit (%)	59 (± 1)	Atterberg tests
Liquid limit (%)	76 (± 2)	Atterberg tests

2.2. MECHANICAL MIXERS

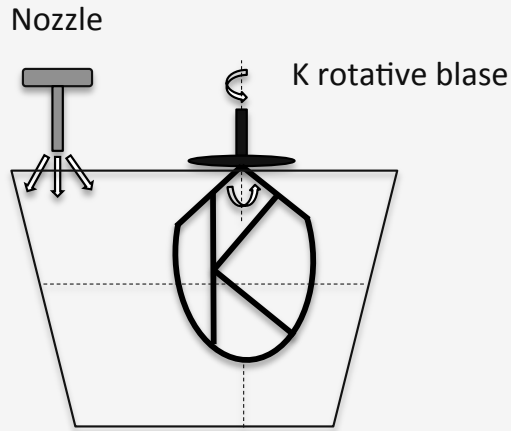

Planetary mixer

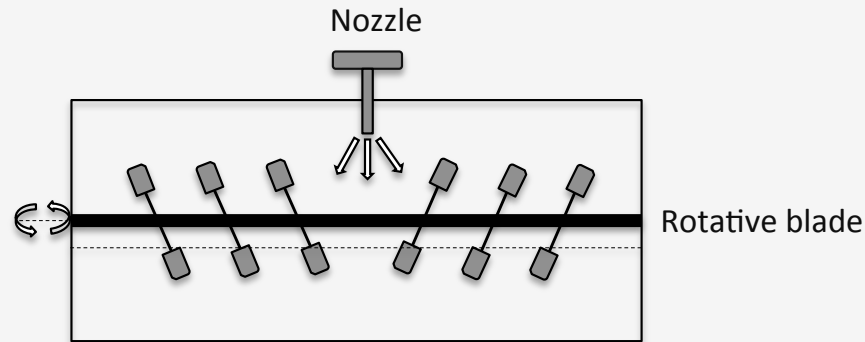

Horizontal mixer

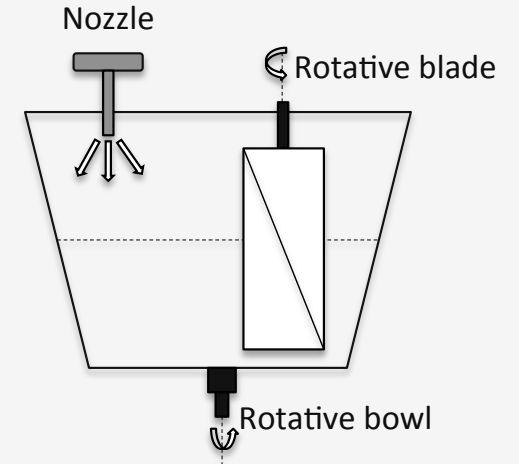

Vertical mixer

Mixers	Speed (rpm)	Froude number (-)	Water content (-)	Mixing time (min)
Planetary	70 - 180	0.03 - 0.16	0.33 - 0.38 - 0.45	0 - 5 - 15
Horizontal	114 - 228	0.02 - 0.05	0.39 - 0.42 - 0.49	0 - 5 - 15
Vertical	80 - 200	0.03 - 0.17	0.33 - 0.38 - 0.45	0 - 5 - 15

2.2. MECHANICAL MIXERS

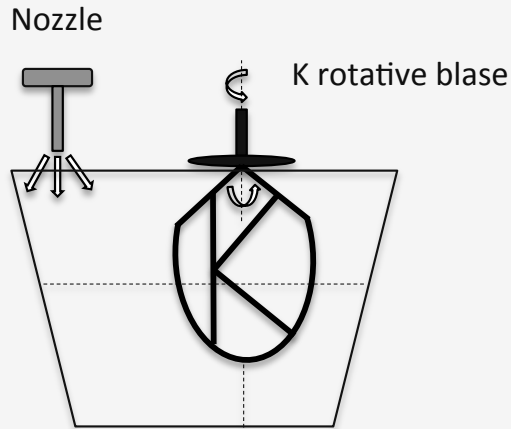

Planetary mixer

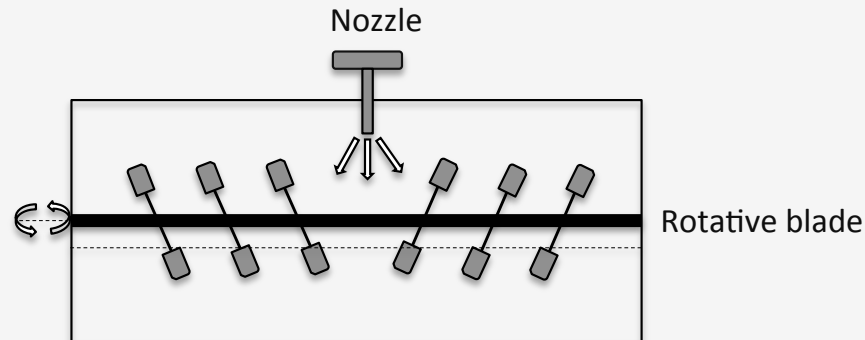

Horizontal mixer

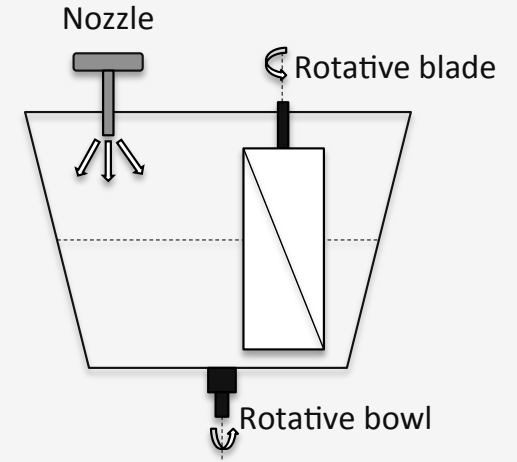

Vertical mixer

Mixers	Speed (rpm)	Froude number (-)	Water content (-)	Mixing time (min)
Planetary	70 - 180	0.03 - 0.16	0.33 - 0.38 - 0.45	0 - 5 - 15
Horizontal	114 - 228	0.02 - 0.05	0.39 - 0.42 - 0.49	0 - 5 - 15
Vertical	80 - 200	0.03 - 0.17	0.33 - 0.38 - 0.45	0 - 5 - 15

2.2. MECHANICAL MIXERS

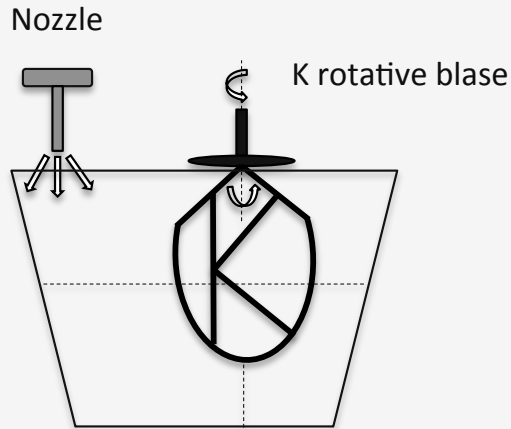

Planetary mixer

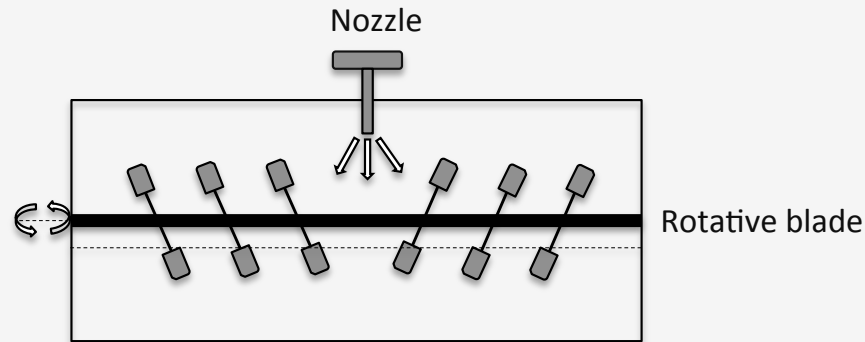

Horizontal mixer

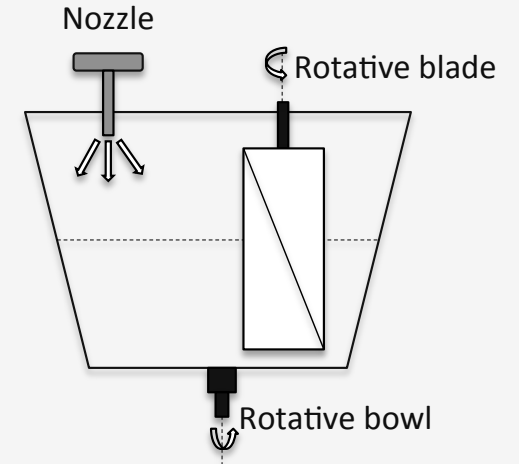

Vertical mixer

Mixers	Speed (rpm)	Froude number (-)	Water content (-)	Mixing time (min)
Planetary	70 - 180	0.03 - 0.16	0.33 - 0.38 - 0.45	0 - 5 - 15
Horizontal	114 - 228	0.02 - 0.05	0.39 - 0.42 - 0.49	0 - 5 - 15
Vertical	80 - 200	0.03 - 0.17	0.33 - 0.38 - 0.45	0 - 5 - 15

2.2. MECHANICAL MIXERS

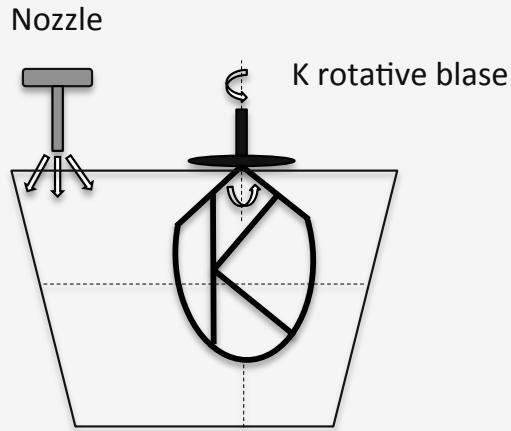

Planetary mixer

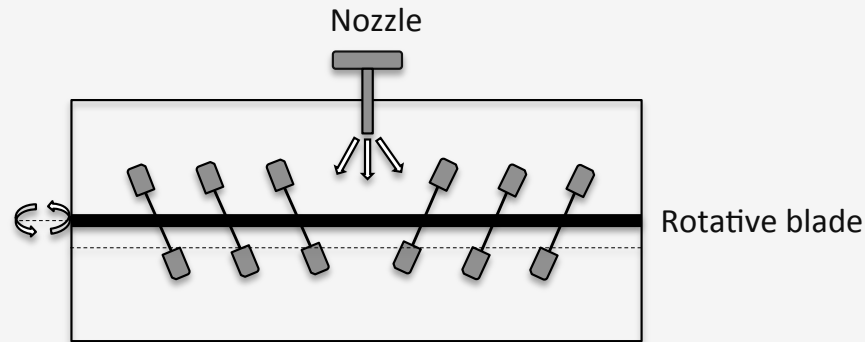

Horizontal mixer

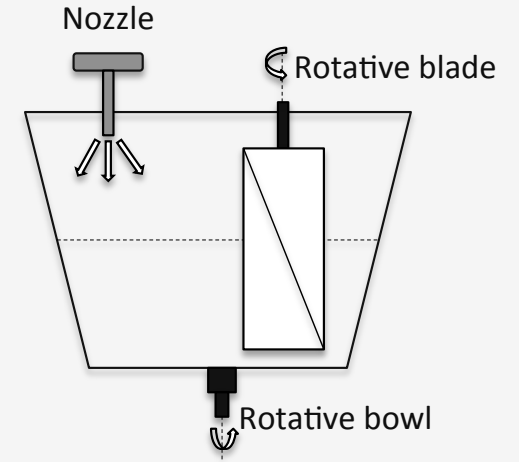

Vertical mixer

Mixers	Speed (rpm)	Froude number (-)	Water content (-)	Mixing time (min)
Planetary	70 - 180	0.03 - 0.16	0.33 - 0.38 - 0.45	0 - 5 - 15
Horizontal	114 - 228	0.02 - 0.05	0.39 - 0.42 - 0.49	0 - 5 - 15
Vertical	80 - 200	0.03 - 0.17	0.33 - 0.38 - 0.45	0 - 5 - 15

2.3. WET GRANULATION PROCESS

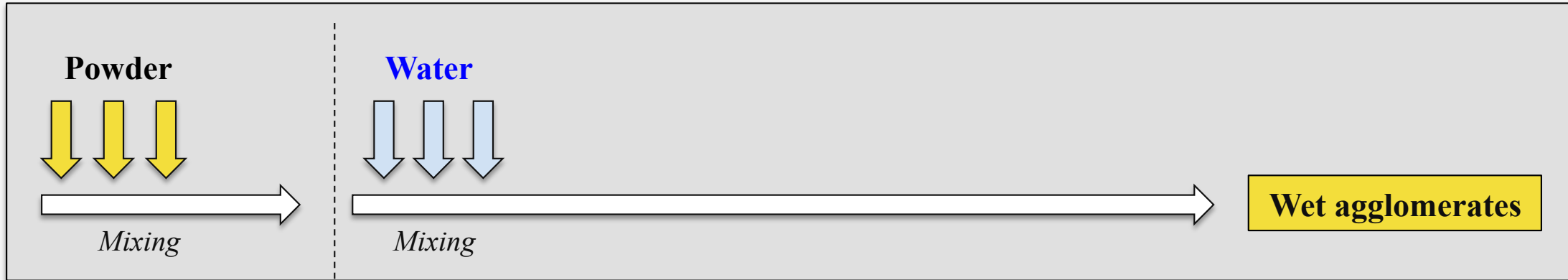

Stage 1 - Mixing

Stage 2 - Water addition and agglomeration



Power consumption by the mixer arm during the process.



Water added manually or using a water **spraying nozzle** with a **constant flow rate** (2 g/sec).



Final mass close to 50% of the capacity of the mixer.

2.4. AGGLOMERATES CHARACTERISTICS

To **describe the agglomeration mechanisms** and the product characteristics, we evaluated the **size distribution** and the **agglomerates characteristics on each sieve**.

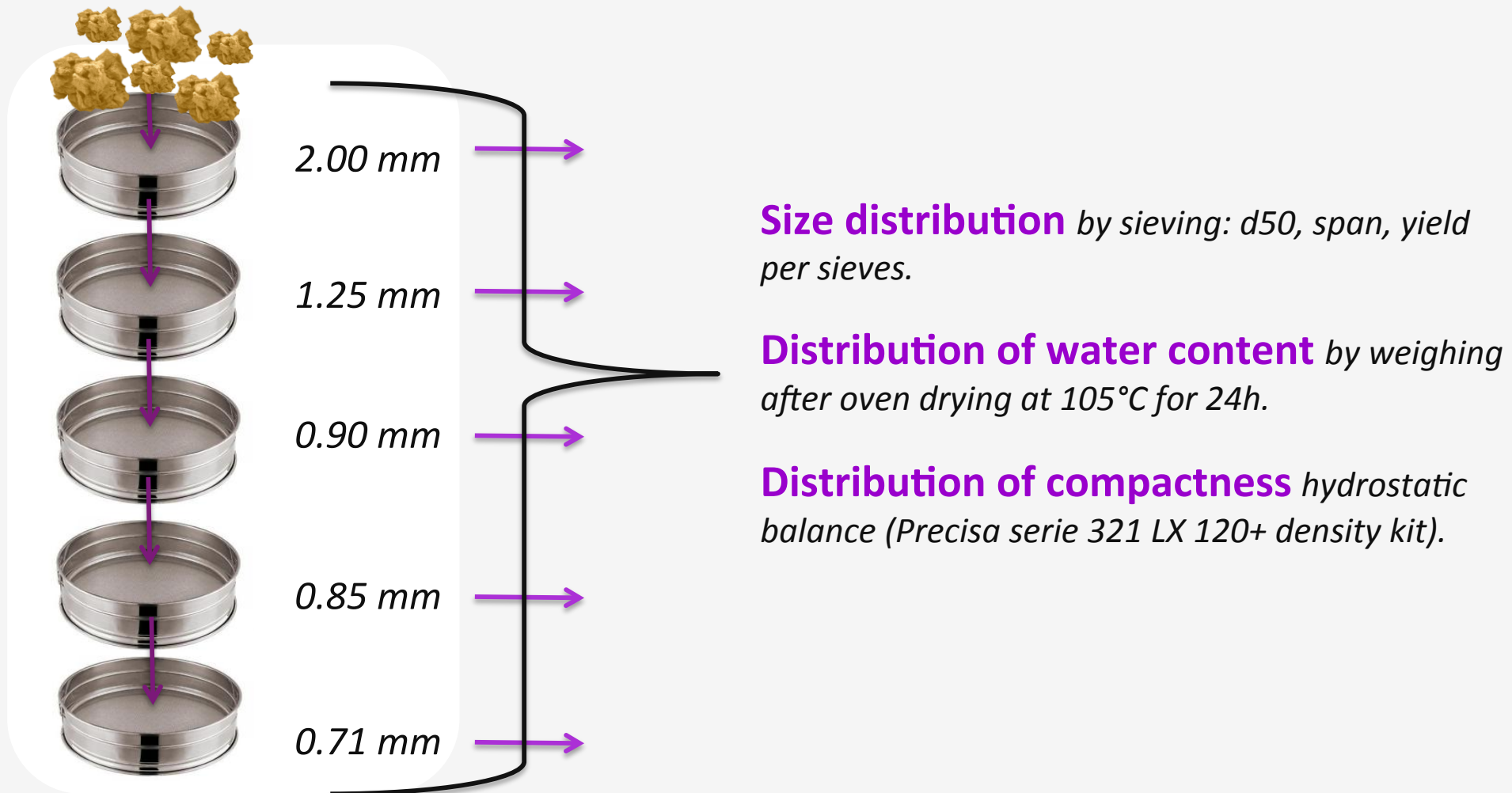



Plan

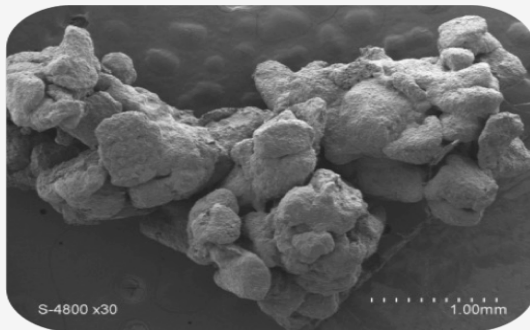

1

INTRODUCTION - WET AGGLOMERATION

2

DURUM WHEAT SEMOLINA AND MIXERS

3

IMPACT OF THE PROCESS

4

HYDROTEXTURAL ANALYSIS

5

CONCLUSION

3.1. DESCRIPTION OF THE GRANULATION

Large dispersion in size was observed. Specific shape and hydrotextural characteristics allow distinguishing **5 types of structures** according to their diameter:

- **Small** (0.3 – 0.5 mm) = native particles of semolina
- **Fragments** (0.5 – 0.6 mm) = mechanical erosion of larger structures
- **Nuclei** (0.6 – 1.0 mm) = primary association of semolina particles
- **Agglomerates** (1.0 – 2.0 mm) = association of fragments and/or nuclei
- **Dough pieces** (>2.0 mm) = association of agglomerates which passes the percolation state

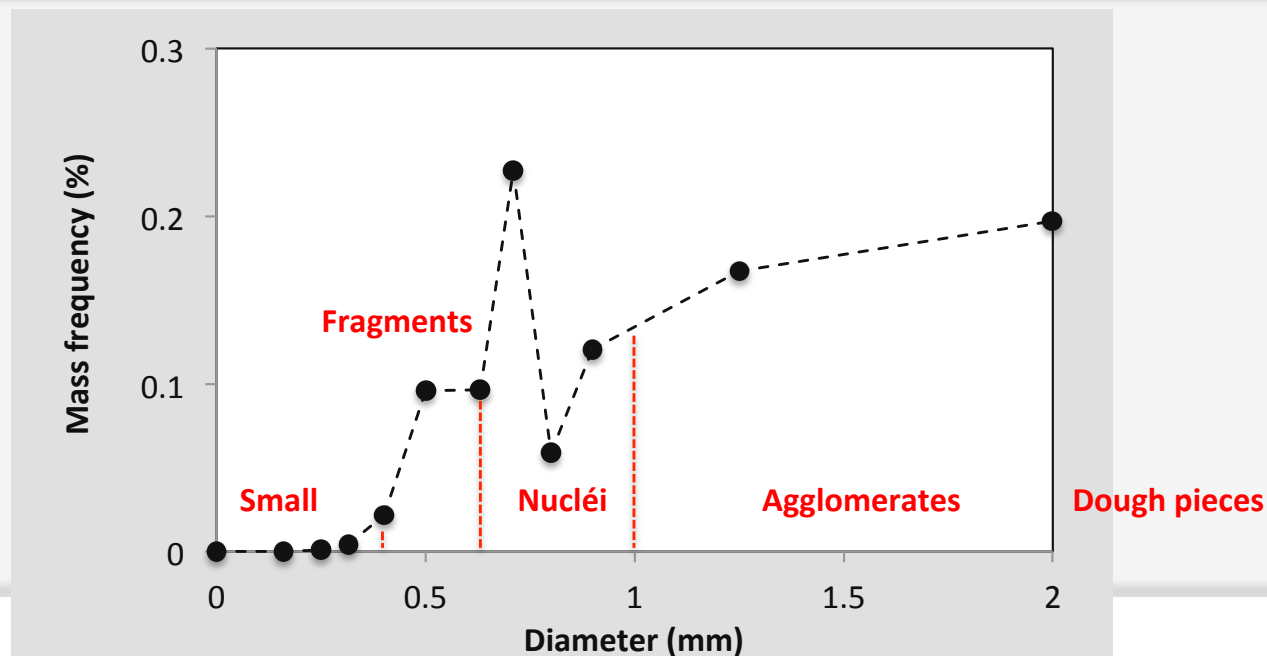

3.1. DESCRIPTION OF THE GRANULATION

Agglomeration growth of semolina to produce couscous grains leads to:

- **Increasing water content**
- **Decreasing compactness**

according to an **increase in the median diameter** of the structures.

Evolution of the size distribution of the agglomerated structures with water content and compactness shows:

- A **continuous growth** process associated with the expansion of their internal structure.
- A **fragmentation** of the dough pieces.

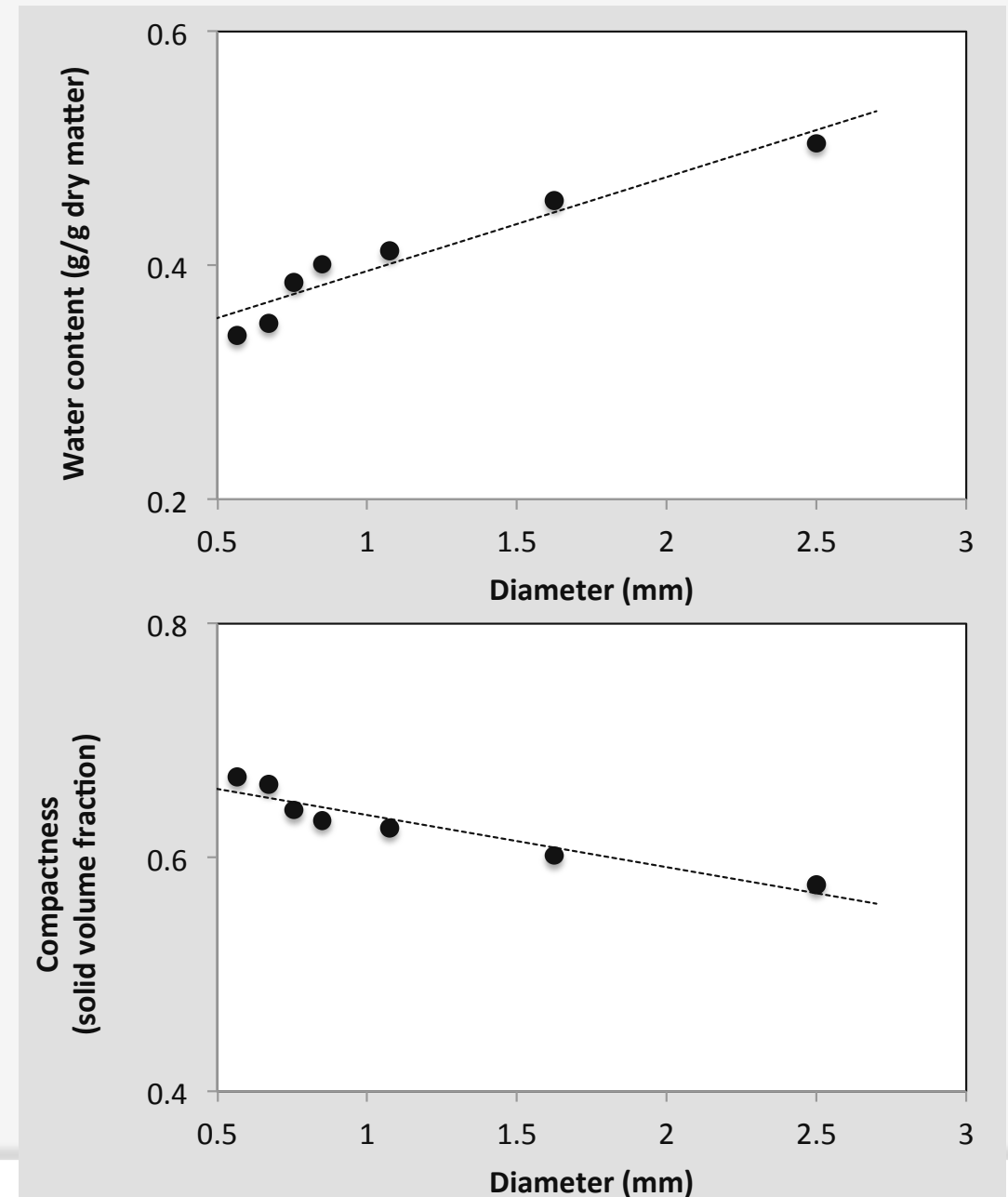

3.2. IMPACT OF THE WATER CONTENT

Polydispersity of the size. **5 structures** with specific characteristics of size, compactness and water content.

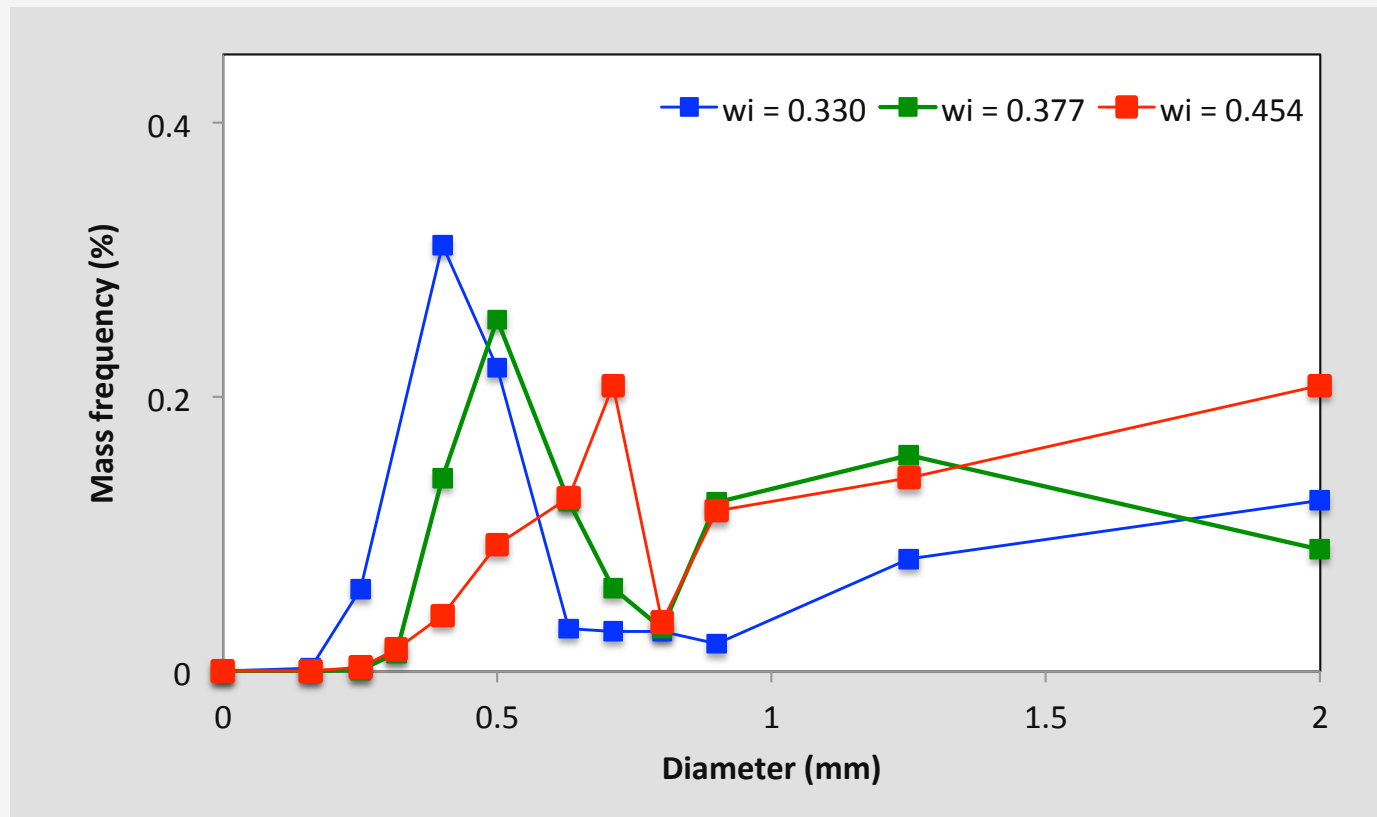

An increase of the water content lead to an increase of the median diameter of the population in the mixer after the granulation.

3.2. IMPACT OF THE WATER CONTENT

An increase of the water content **increase the mean water content** of each structure after the granulation.

An increase of the water content **decrease the mean compactness** content of each structure after the granulation.

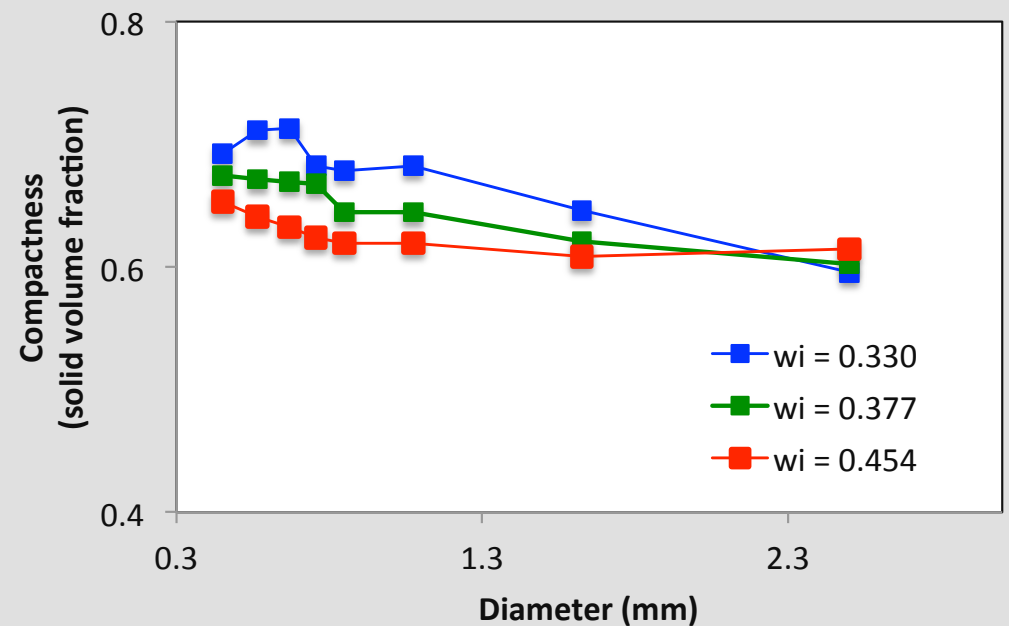
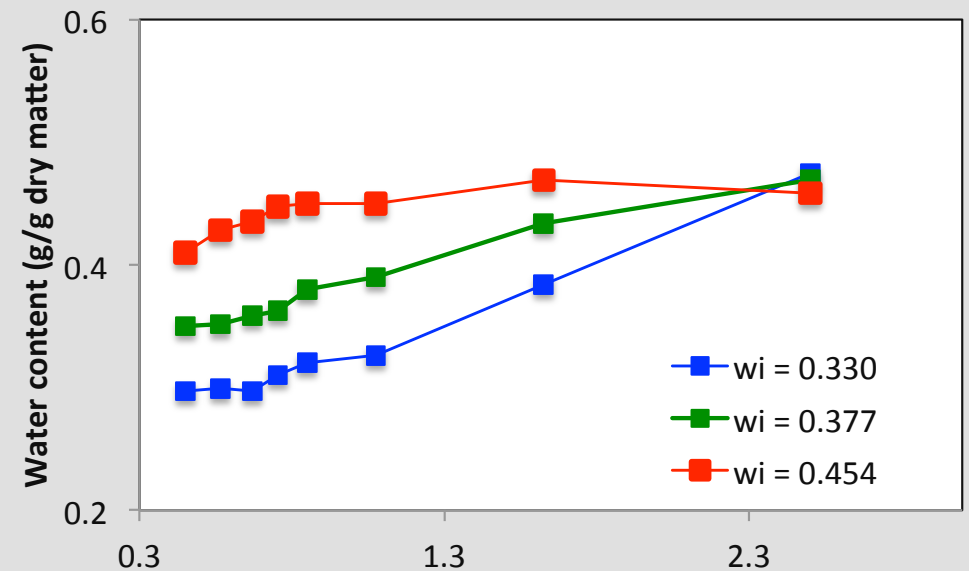

3.3. IMPACT OF THE MIXING SPEED

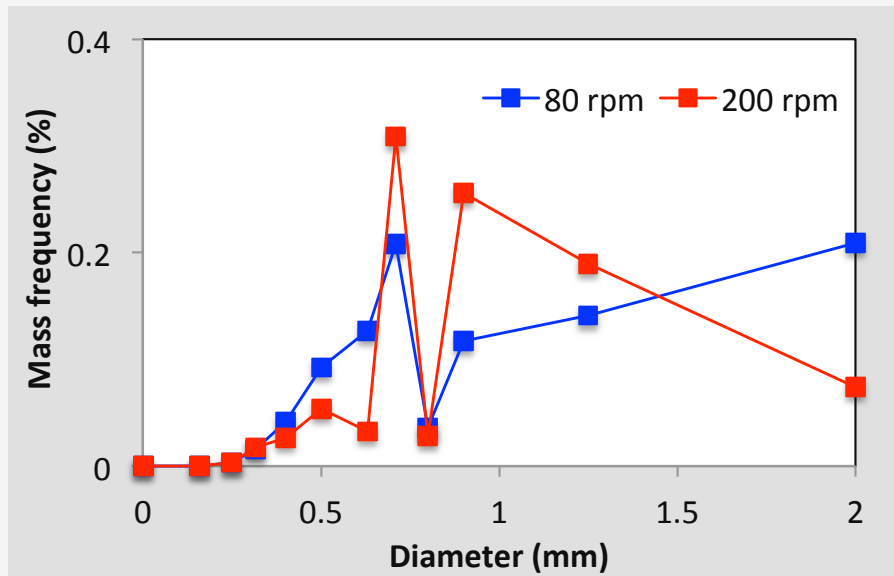

- The ratio of the 5 structures is different → An increase of the speed leads to an **increase of the breakage and erosion mechanisms.**

- **No impact of the speed in the water content and the compactness of each structure.**

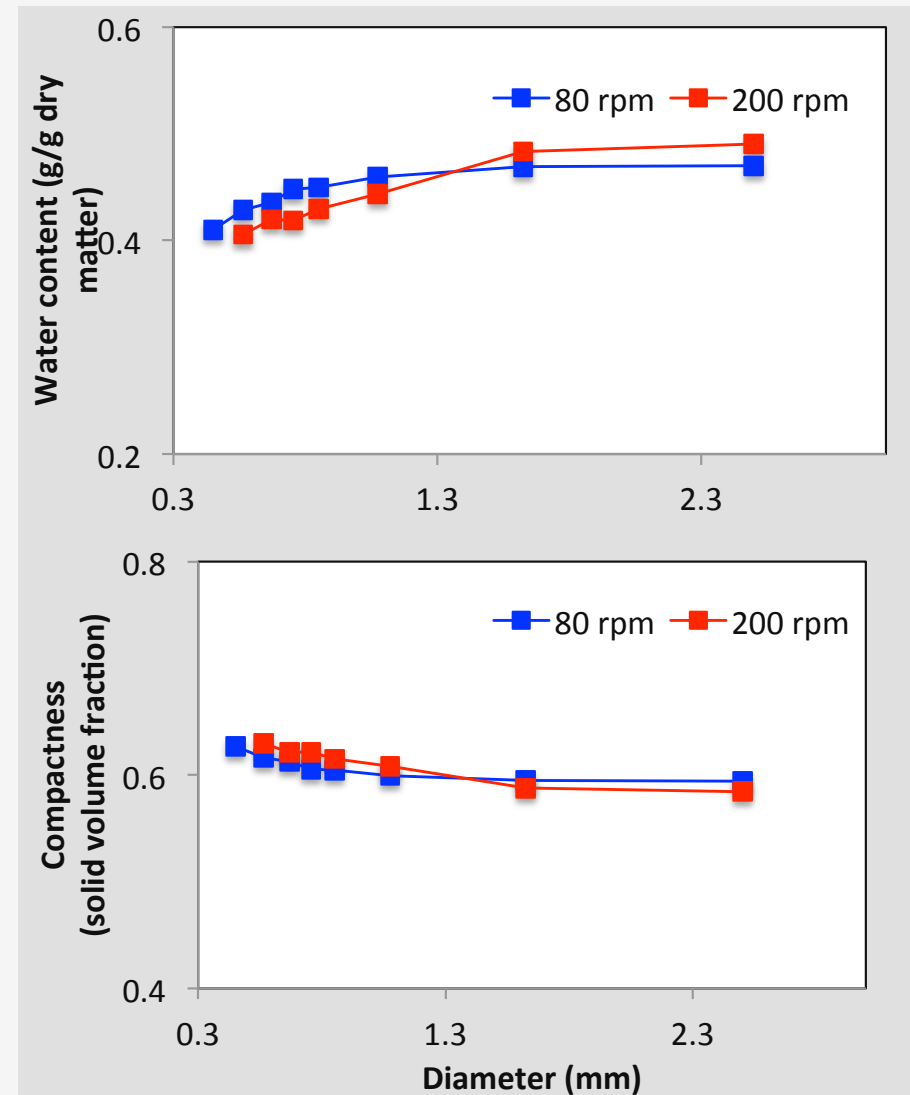

3.4. IMPACT OF THE MIXERS

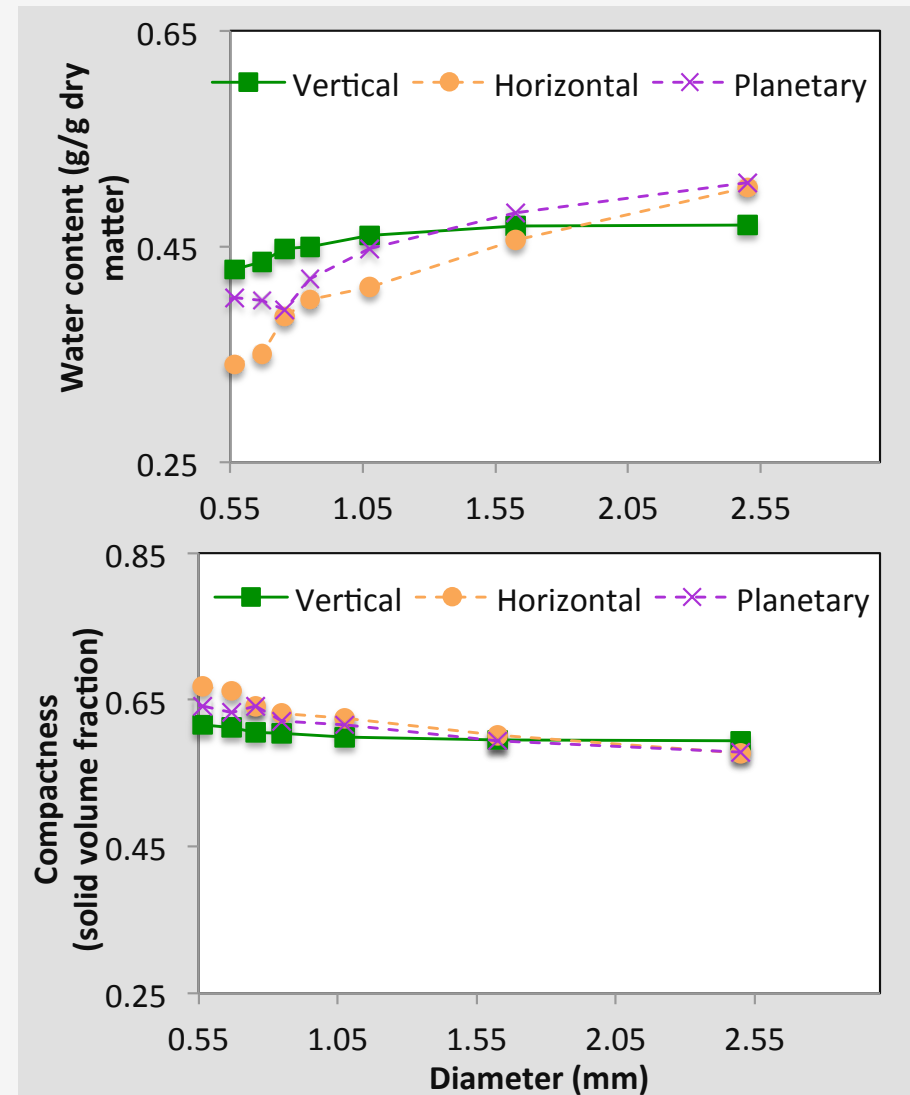
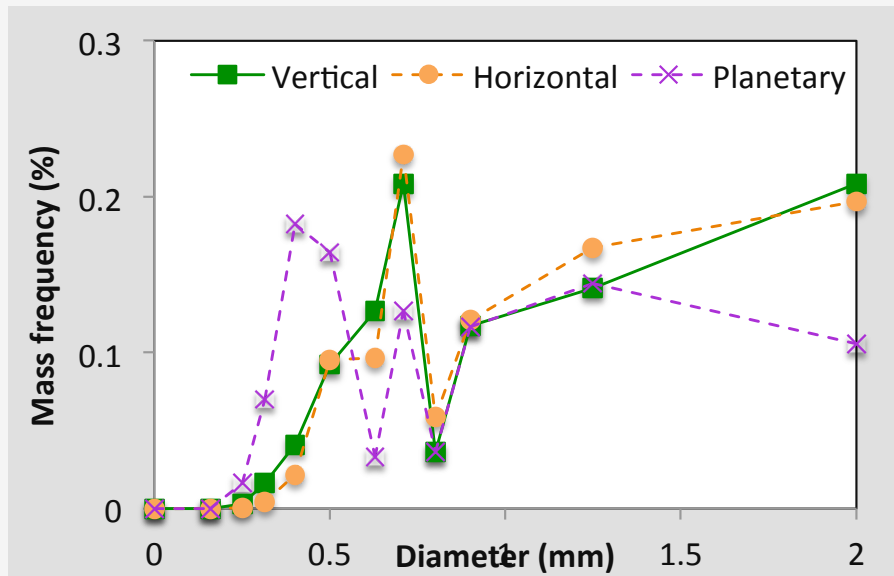

- The ratio of the 5 structures is different → More **breakage and erosion mechanisms** in the planetary mixer.
- The mixers **do not have an impact** on the **water content** and the **compactness** of each structure.



Plan

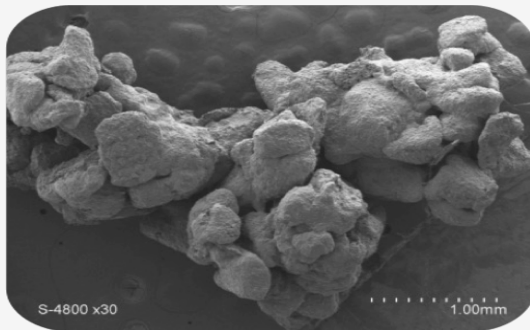

1

INTRODUCTION - WET AGGLOMERATION

2

DURUM WHEAT SEMOLINA AND MIXERS

3

IMPACT OF THE PROCESS

4

HYDROTEXTURAL ANALYSIS

5

CONCLUSION

4.1. DATA ANALYSIS

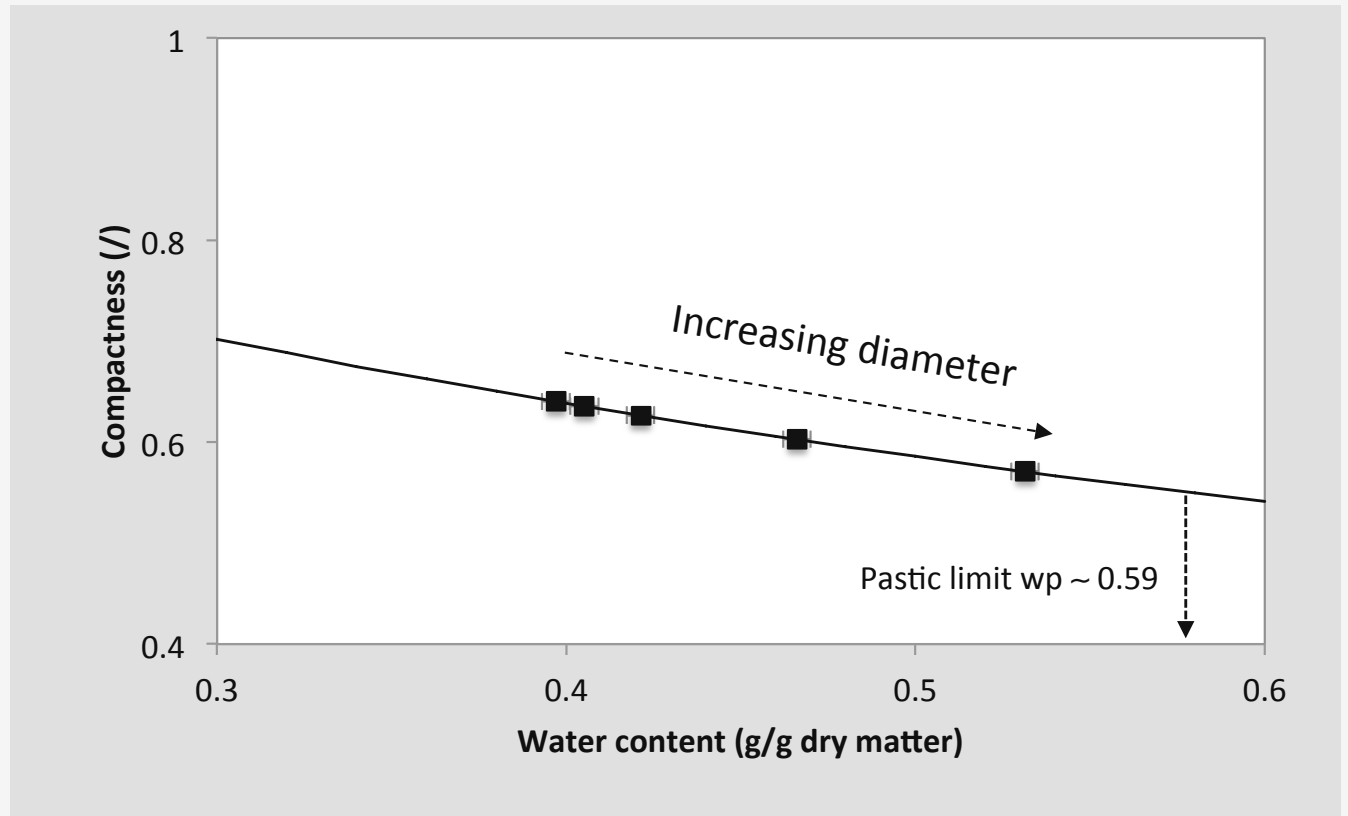

4.1. DATA ANALYSIS

Analysis of the **mean values** of water content and compactness.

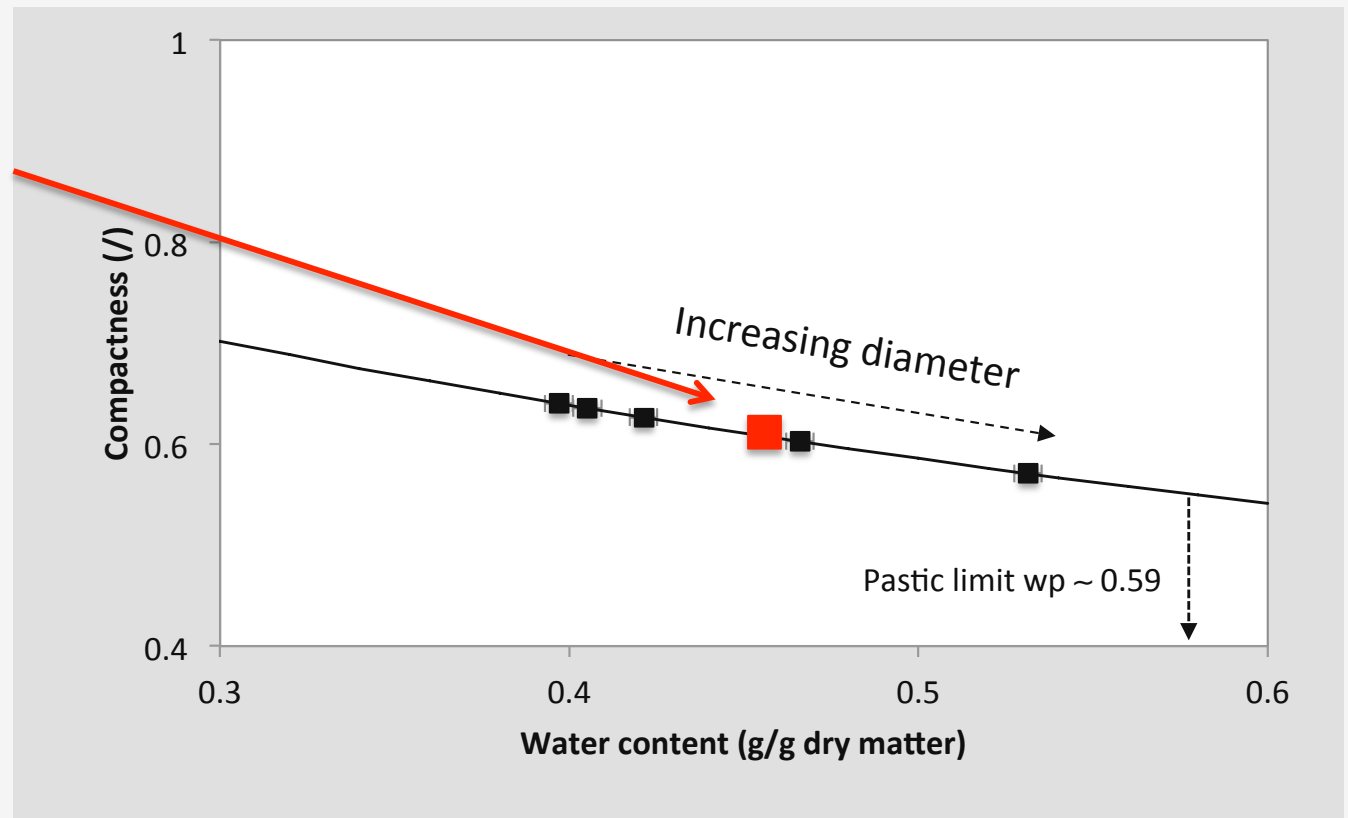

4.1. DATA ANALYSIS

Analysis of the **mean values** of water content and compactness.

Analysis of the **heterogeneity** of water content and compactness around their mean values.

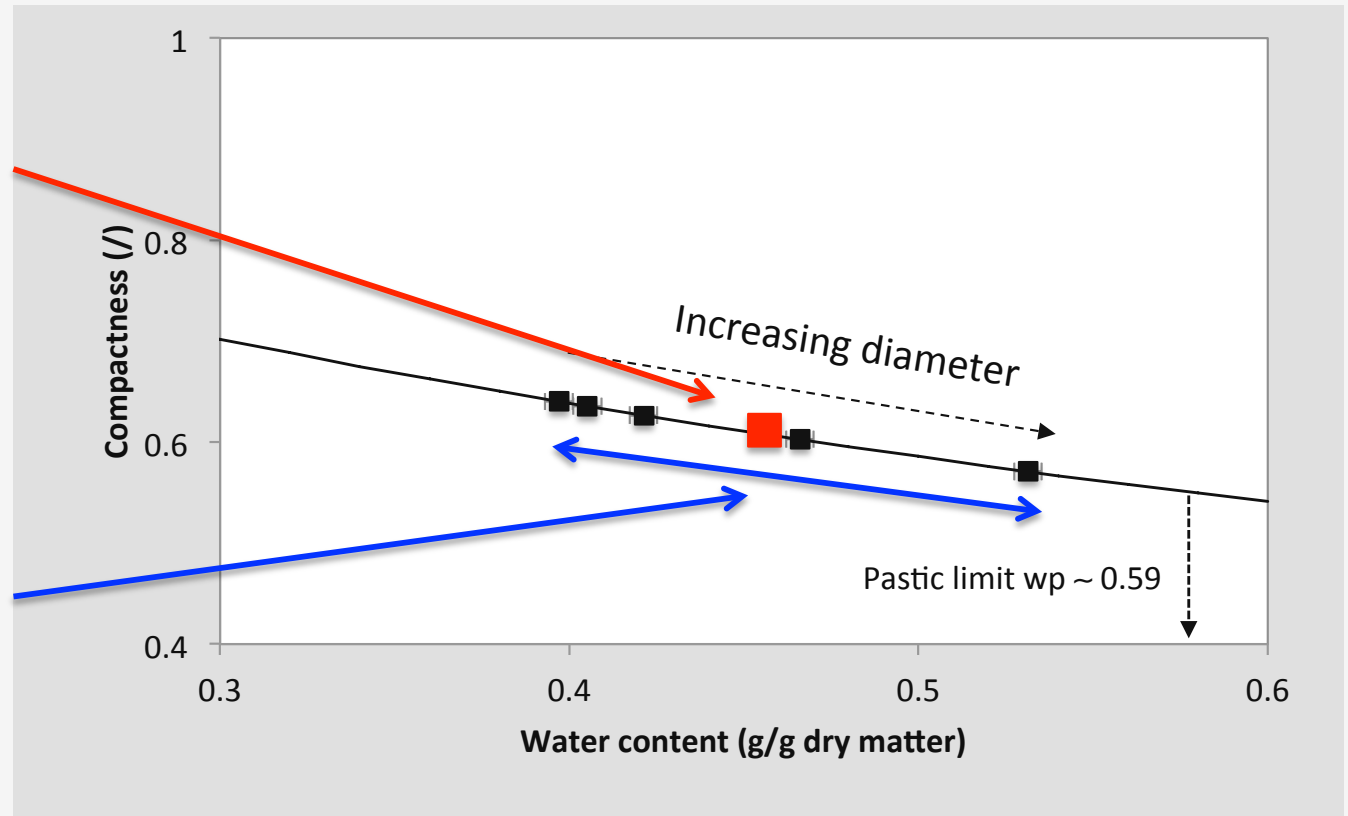

4.1. DATA ANALYSIS

Analysis of the **mean values** of water content and compactness.

Analysis of the **heterogeneity** of water content and compactness around their mean values.

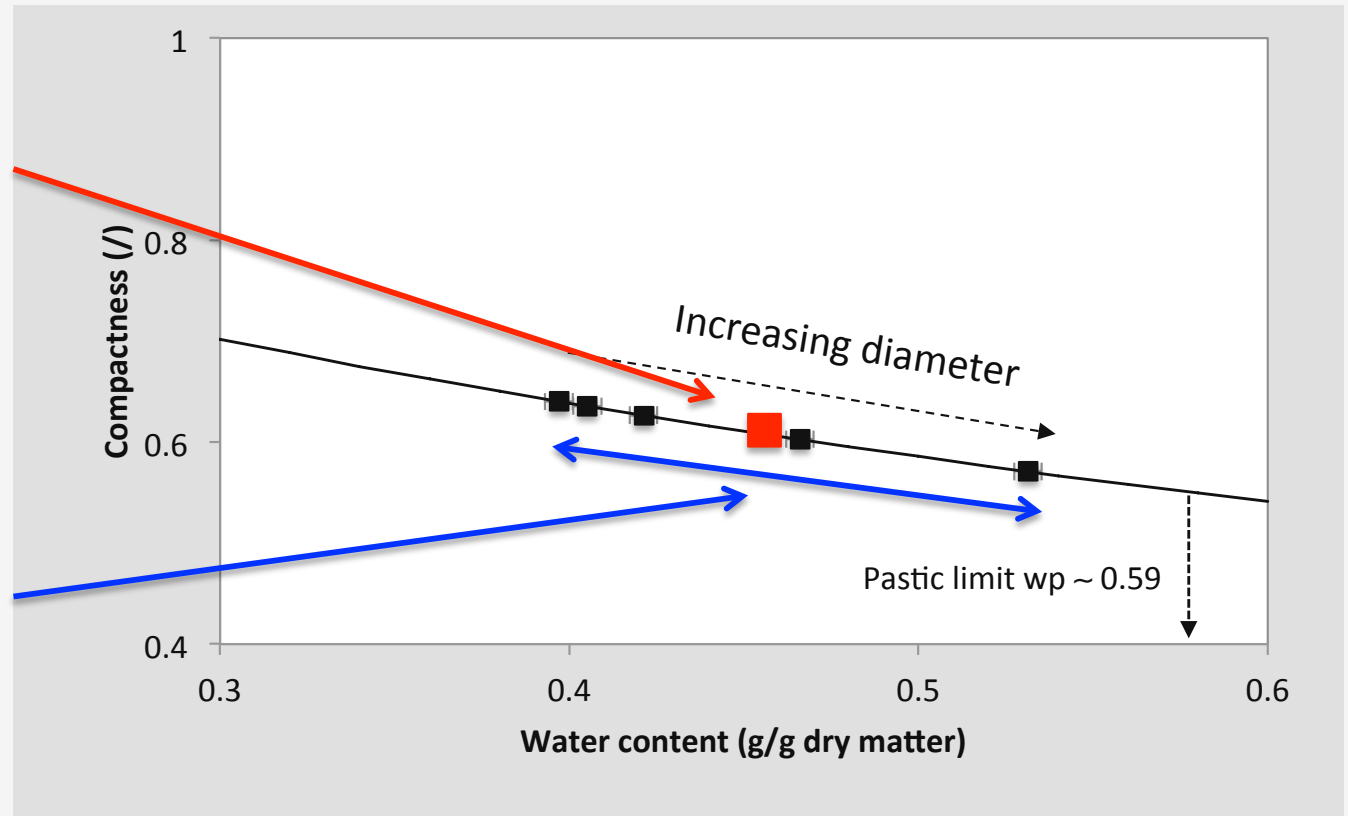

Global heterogeneity

$$W_G = (W_{\max} - W_{\min}) / W_{\text{moy}}$$

4.1. DATA ANALYSIS

Analysis of the **mean values** of water content and compactness.

Analysis of the **heterogeneity** of water content and compactness around their mean values.

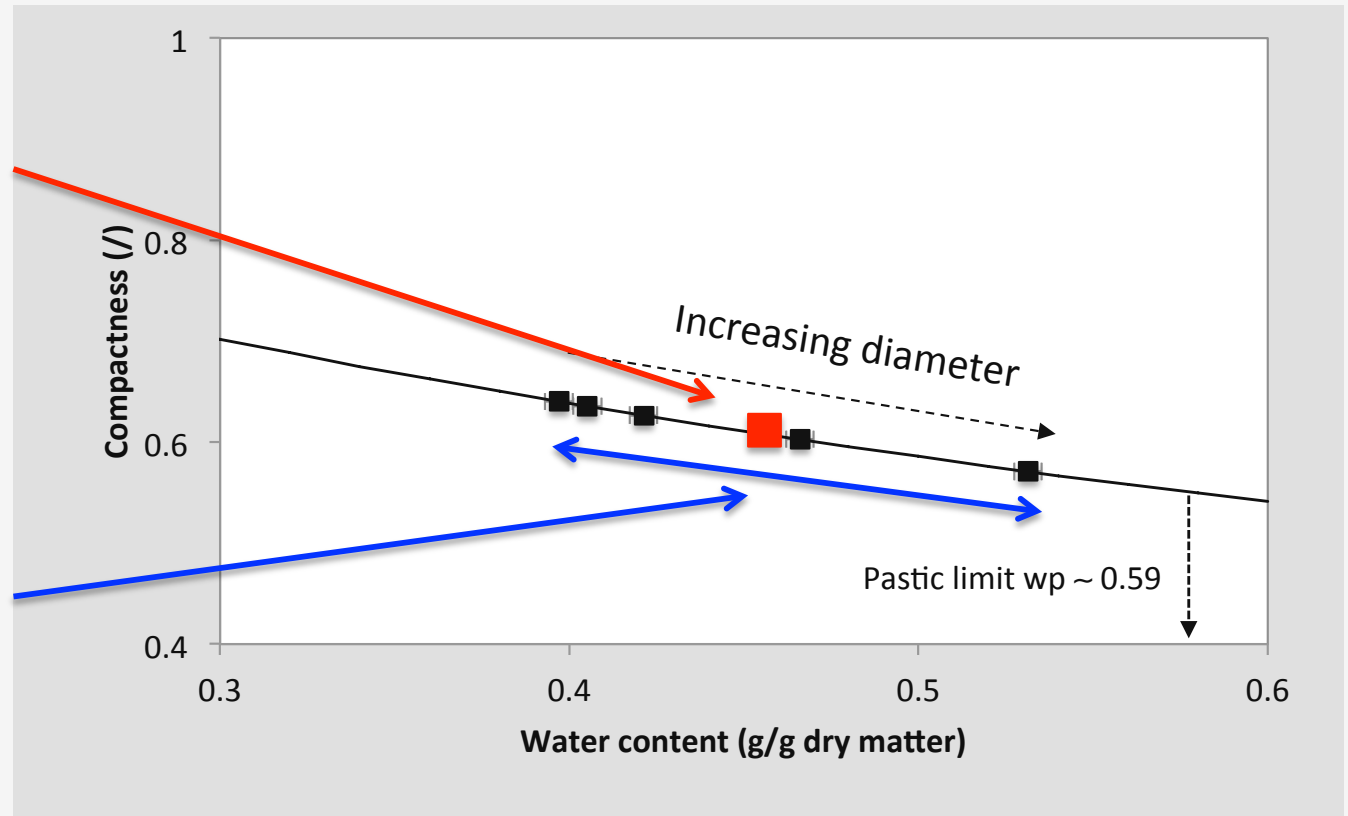

Global heterogeneity

$$W_G = (W_{\max} - W_{\min}) / W_{\text{moy}}$$

Local heterogeneity

$$W_L = (W - W_{\text{moy}}) / W_{\text{moy}}$$

4.2. MEAN VALUES ANALYSIS

We have represented on the diagram **the mean values** of **water content** and **compactness** of the structures **for all the process conditions**.

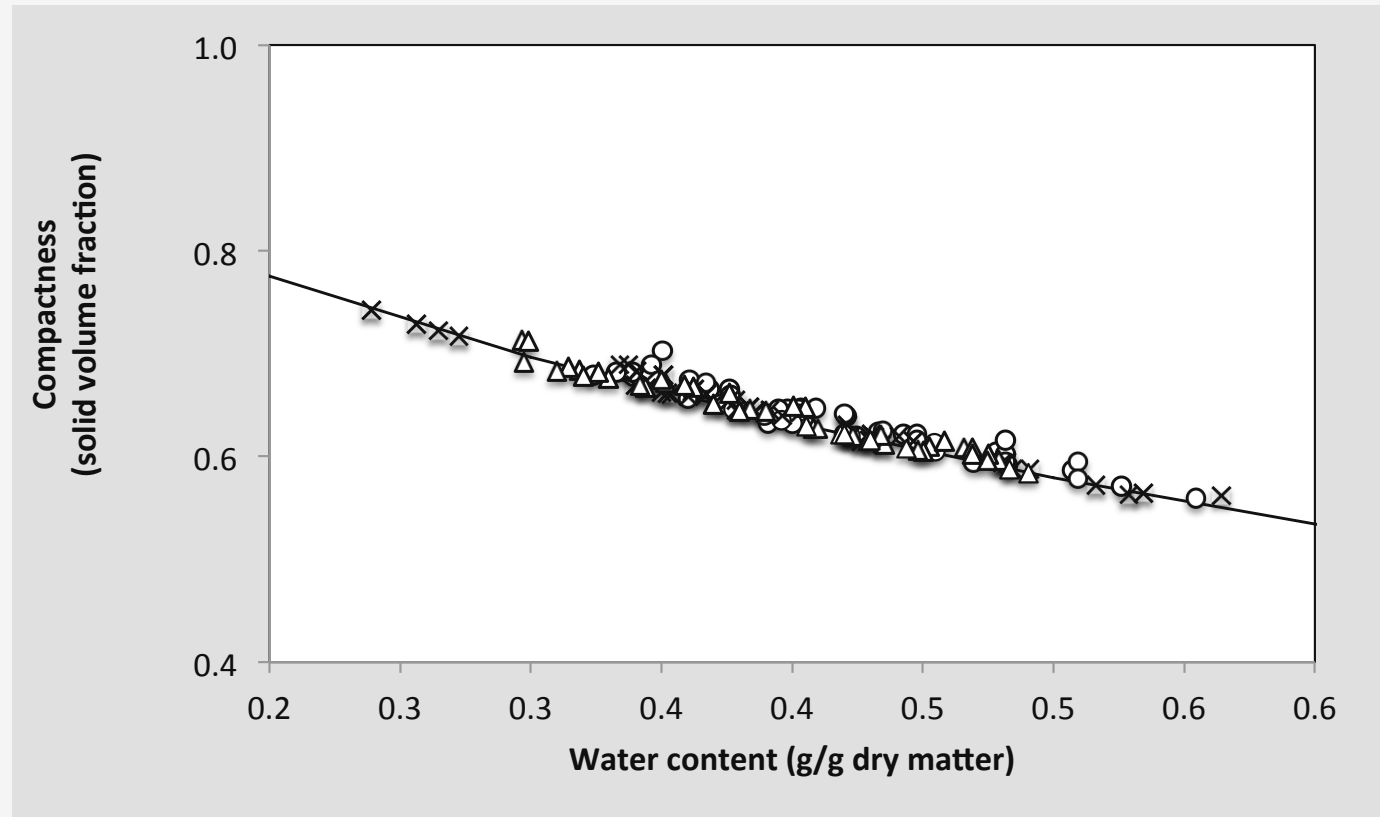

The process conditions **do not change the hydrotextural properties** of the structures: they are **all saturated by water**.

4.3. LOCAL HETEROGENEITY ANALYSIS

The **fluctuations** of the **water content** and the **compactness** are **correlated** around their respective mean values **for all the process conditions**.

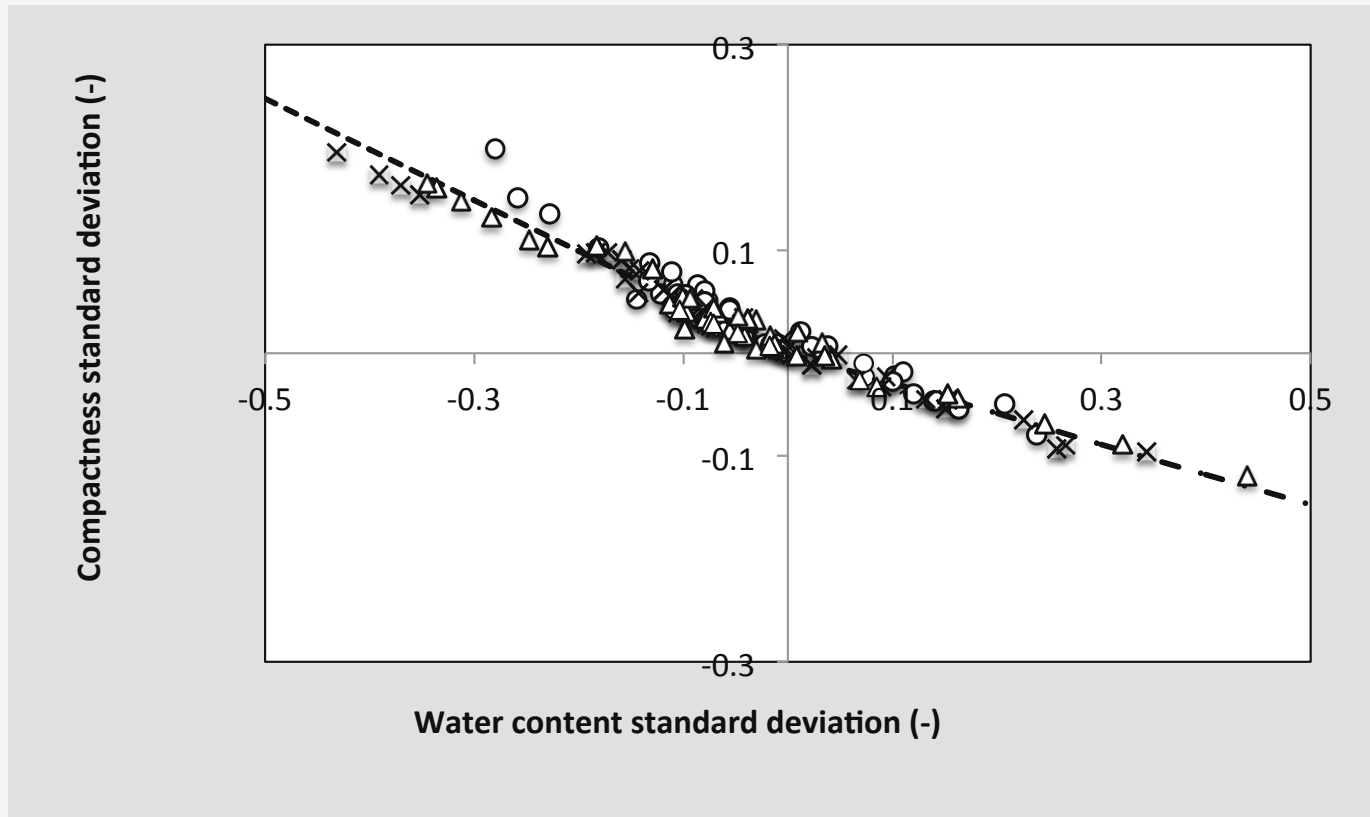

The growth of the agglomerates respects an **association by same sizes and hydro-textural categories**.



Plan

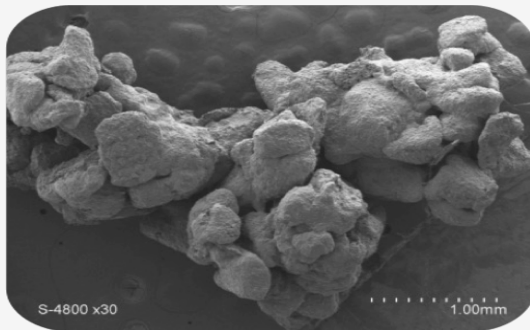

1

INTRODUCTION - WET AGGLOMERATION

2

DURUM WHEAT SEMOLINA AND MIXERS

3

IMPACT OF THE PROCESS

4

HYDROTEXTURAL ANALYSIS

5

CONCLUSION

CONCLUSION

- **5 structures** in the mixer after the granulation.
- Continuous growth process is associated with the **expansion of the internal structure**.
- The **process** (water content, speed and mixers) has a **significant influence on the yield** of the agglomeration, but...
- ... **does not have an influence on the agglomerates properties** (water content and compactness) as a function to their size.
- **Fluctuations** of the water content and the compactness are correlated around their respective mean values → **association by same sizes and hydro-textural categories**.

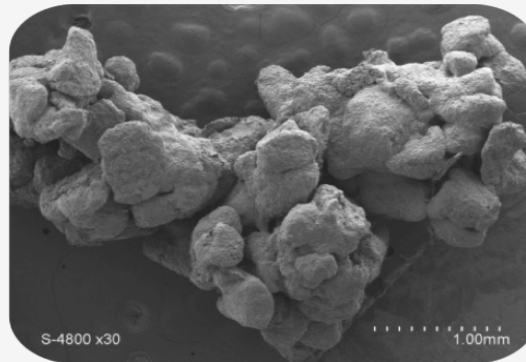

Thanks for your attention

QUESTIONS ?

Bettina Bellocq

Under the supervision of:

Pr. Bernard CUQ, Dr. Thierry RUIZ and Dr. Agnès DURI

UMR IATE – INRA Montpellier – France

16^{ème} Congrès de la Société Française de Génie des Procédés

Nancy – 12 Juillet 2017

