



**HAL**  
open science

## Vibration-based angular speed estimation for multi-stage wind turbine gearboxes

Cédric Peeters, Quentin Leclere, Jérôme Antoni, Patrick Guillaume, Jan  
Helsen

► **To cite this version:**

Cédric Peeters, Quentin Leclere, Jérôme Antoni, Patrick Guillaume, Jan Helsen. Vibration-based angular speed estimation for multi-stage wind turbine gearboxes. International Conference on Damage Assessment of Structures, Jul 2017, Kitakyushu, Japan. pp.12053 - 12053, 10.1088/1742-6596/842/1/012053 . hal-01595869

**HAL Id: hal-01595869**

**<https://hal.science/hal-01595869>**

Submitted on 27 Sep 2017

**HAL** is a multi-disciplinary open access archive for the deposit and dissemination of scientific research documents, whether they are published or not. The documents may come from teaching and research institutions in France or abroad, or from public or private research centers.

L'archive ouverte pluridisciplinaire **HAL**, est destinée au dépôt et à la diffusion de documents scientifiques de niveau recherche, publiés ou non, émanant des établissements d'enseignement et de recherche français ou étrangers, des laboratoires publics ou privés.

## Vibration-based angular speed estimation for multi-stage wind turbine gearboxes

This content has been downloaded from IOPscience. Please scroll down to see the full text.

2017 J. Phys.: Conf. Ser. 842 012053

(<http://iopscience.iop.org/1742-6596/842/1/012053>)

View [the table of contents for this issue](#), or go to the [journal homepage](#) for more

Download details:

IP Address: 134.214.215.131

This content was downloaded on 06/06/2017 at 05:58

Please note that [terms and conditions apply](#).

You may also be interested in:

[Extraction of Gearbox Fault Features from Vibration Signal Using Wavelet Transform](#)

X P Ren, W Shao, W Z Yang et al.

[Vibration-based SHM System: Application to Wind Turbine Blades](#)

D Tcherniak and L L Mølgaard

[The use of strain gauges in vibration-based damage detection](#)

Fabio Luis Marques dos Santos, Bart Peeters, Jenny Lau et al.

[Analysis of Counter-Rotating Wind Turbines](#)

W Z Shen, V A K Zakkam, J N Sørensen et al.

[Effects of Icing on Wind Turbine Fatigue Loads](#)

Peter Frohboese and Andreas Anders

[CFD analysis for siting of wind turbines on high-rise buildings](#)

K Veena, V Asha, C Arshad Shameem et al.

[Evaluation of the vehicle state with vibration-based diagnostics methods](#)

V E Gai, I V Polyakov, M S Krasheninnikov et al.

[Design of a novel and efficient lantern wind turbine](#)

M D Ibrahim, L K Wong, M Anyi et al.

[Analysis of Power Enhancement for a Row of Wind Turbines Using the Actuator Line Technique](#)

Robert Mikkelsen, Jens N Sørensen, Stig Øye et al.

# Vibration-based angular speed estimation for multi-stage wind turbine gearboxes

Cédric Peeters<sup>1,a</sup>, Quentin Leclère<sup>2</sup>, Jérôme Antoni<sup>2</sup>, Patrick Guillaume<sup>1</sup>, Jan Helsen<sup>1</sup>

<sup>1</sup>Vrije Universiteit Brussel, Pleinlaan 2, 1050 Brussel, Belgium

<sup>2</sup>LVA, INSA de Lyon, F-69621, Villeurbanne cedex, France

E-mail: <sup>a</sup>Cedric.Peeters@vub.ac.be

**Abstract.** Most processing tools based on frequency analysis of vibration signals are only applicable for stationary speed regimes. Speed variation causes the spectral content to smear, which encumbers most conventional fault detection techniques. To solve the problem of non-stationary speed conditions, the instantaneous angular speed (IAS) is estimated. Wind turbine gearboxes however are typically multi-stage gearboxes, consisting of multiple shafts, rotating at different speeds. Fitting a sensor (e.g. a tachometer) to every single stage is not always feasible. As such there is a need to estimate the IAS of every single shaft based on the vibration signals measured by the accelerometers. This paper investigates the performance of the multi-order probabilistic approach for IAS estimation on experimental case studies of wind turbines. This method takes into account the meshing orders of the gears present in the system and has the advantage that a priori it is not necessary to associate harmonics with a certain periodic mechanical event, which increases the robustness of the method. It is found that the MOPA has the potential to easily outperform standard band-pass filtering techniques for speed estimation. More knowledge of the gearbox kinematics is beneficial for the MOPA performance, but even with very little knowledge about the meshing orders, the MOPA still performs sufficiently well to compete with the standard speed estimation techniques. This observation is proven on two different data sets, both originating from vibration measurements on the gearbox housing of a wind turbine.

## 1. Introduction

Wind turbines experience strong dynamical loads during their lifetime that can lead to considerable reduction of the expected life of a wind turbine's drivetrain[1]. Changes in the behavior of the wind and the electricity grid can influence significantly the loads on the drivetrain and thus its lifetime. Gearboxes especially are prone to unexpected premature failures and are costly to replace due to the substantial downtime[2]. Reducing the amount of critical failures and thus increasing wind turbine reliability has the potential to drastically decrease the actual cost of electricity [3].

Current condition monitoring systems often utilize vibration measurements to assess the health of the internals of a gearbox, like the shafts, gears or bearings. Most of these vibration-based systems rely on spectral analysis of the measured vibration signals. Methods based on tracking spectral content however generally assume the rotation speed of the system to be constant or quasi constant. In practical applications like wind turbines, this requirement is unlikely to be met due to the highly dynamic character. To enable the synchronization



of the spectral analysis, the instantaneous angular speed (IAS) can be measured by using a tachometer. However the installation and cost of a tachometer is not always feasible or desirable and thus recent developments focus on extracting the IAS directly from the vibration signal. Several approaches already exist and some common techniques include Vold-Kalman filtering [4, 5], Gabor and wavelet transforms [6, 7], band-pass filtering[8] and the Teager-Kaiser energy operator[9]. However most of these techniques rely on the presence of a frequency band that contains only a harmonic of the rotation frequency with a high signal-to-noise ratio (SNR). Other signal components like harmonics that are not related to the rotation speed of interest, or structural resonances are not desirable in the frequency band and usually ruins the chances of successfully extracting the IAS. Since wind turbine gearboxes are usually a complex system consisting of multiple (planetary) stages, the vibration signals measured from such a complex system contain multiple resonances and asynchronous harmonics. As such the assumption of a frequency band containing only one harmonic with high SNR cannot be guaranteed.

The limitation of only taking taking into account one harmonic hints at an approach that utilizes as many harmonics as possible in order to increase the amount of information and correspondingly the accuracy. This paper investigates exactly such a method, namely the multi-order probabilistic approach (MOPA) as first proposed by Leclère et al. [10]. This method uses the available information about the system and does not require to associate one harmonic with the correct order. Knowledge of the gear ratios only is sufficient to extract from the vibration signal an accurate estimation of the IAS.

## 2. Methodology

This paper compares the IAS estimation accuracy of two methods against each other on two experimental data sets of wind turbine gearboxes. This section briefly describes the theoretical background of both methods.

### 2.1. Multi-order probabilistic approach

The general idea behind the multi-order probabilistic approach (MOPA) as proposed by Leclère et al. [10] is based on regarding the instantaneous spectrum (which can be obtained through a short time Fourier transform) of the vibration signal as a probability density function (pdf) of the IAS  $\Omega$ . Consequently, if the spectrum has a high amplitude at frequency  $f$ , there is a high probability that the shaft frequency is equal to  $f/H_i$  with  $H_i$  being the excitation order or for the cases described below the gear ratios. It is important to define a range for the IAS in which the user expects the IAS to reside. This range has a lower bound  $\Omega_{min}$  and an upper bound  $\Omega_{max}$ . The following pdf can then be constructed:

$$\begin{cases} [\Omega|H_i] = \frac{1}{\xi_i} A(H_i\omega) & \text{for } \Omega_{min} < \omega < \Omega_{max} \\ [\Omega|H_i] = 0 & \text{for } \omega < \Omega_{min} \text{ — } \omega > \Omega_{max} \end{cases} \quad (1)$$

with  $A(f)$  a whitened version of the vibration signal's spectrum and  $\xi_i$  a normalization factor to make sure the pdf has unit area:

$$\xi_i = \int_{\Omega_{min}}^{\Omega_{max}} A(H_i\omega) d\omega. \quad (2)$$

The purpose of the whitening is essentially to reduce the influence of resonances on the generated pdf, since it is undesirable to give a too high probability to a certain part of the spectrum only due to the increased amplitudes because of a resonance.

To improve the IAS estimation and utilize more of the information potential of the spectrum, one has to include more than just one pdf based on one gear ratio or meshing order. Afterwards

these different pdfs can be combined together in one pdf by multiplication. Equation 1 does not take into account the possibility that a part of the spectrum for a certain harmonic  $H_i$  can exceed the Nyquist frequency. In this case the pdf is made uniform above  $f_{max}/H_i$ :

$$\begin{cases} [\Omega|H_i] = \frac{1}{\xi_i} A(H_i\omega) & \text{for } \Omega_{min} < \omega < f_{max}/H_i \\ [\Omega|H_i] = \frac{1}{\Omega_{max}-\Omega_{min}} [\Omega|H_i] = 0 & \text{for } \omega < \Omega_{min} - \omega > \Omega_{max} \end{cases} \quad (3)$$

with  $\xi_i$  now:

$$\xi_i = \frac{\Omega_{max} - \Omega_{min}}{f_{max}/H_i - \Omega_{min}} \int_{\Omega_{min}}^{f_{max}/H_i} A(H_i\omega) d\omega. \quad (4)$$

The method's inputs are thus an approximate range for the IAS, the meshing orders and the vibration signal. For every order a pdf is then constructed based on the signal's instantaneous spectrum and rescaled to the given range for the IAS. Next, the pdfs are multiplied to combine the information of all the orders so that the main corresponding estimate for the IAS becomes the most dominant peak in the pdf.

Currently the pdfs are still independently generated for each time step and thus do not guarantee any continuity of the IAS, which is a logical assumption for any mechanical system. Due to the inertia of the rotating shafts, strong acceleration or deceleration is improbable. As such, to improve the results further, an a priori of continuity is introduced for the IAS. The concept relies on generating for each time step a pdf that is based on the pdfs of several time steps before and after the central pdf. Appropriate weighting of these pdfs is done by convolving the pdf with a centered Gaussian and the time relationship is introduced by letting the variance depend on the time between the considered pdf and the central pdf. The pdf at time step  $j$  generated by the pdf at time step  $j+k$  is defined as:

$$[\Omega_j]_{j+k} = \int_{\Omega_{min}}^{\Omega_{max}} [\Omega_j|\Omega_{j+k}] d\omega \propto \exp\left(-\frac{\omega^2}{2\sigma_k^2}\right) * [\Omega_{j+k}] \quad (5)$$

with  $[\Omega_j]_{j+k}$  the pdf at time  $j$  that can be obtained by convolution of the pdf at time  $j+k$   $[\Omega_{j+k}]$  with a centered Gaussian, and  $\sigma_k = |\gamma k \Delta_t|$  with  $\Delta_t$  being the time step,  $\gamma$  the standard acceleration of the IAS. Similar to the previous step in which the pdfs corresponding to the different orders have to be multiplied for each time step to obtain a single combined pdf, there are now again multiple pdfs for every time step  $j+k$  belonging to time steps before and after time step  $j$ . Thus the final step is to multiply again all the pdfs for every time step:

$$[\Omega_j]_s \propto \prod_{k=-K}^K [\Omega_j]_{j+k}. \quad (6)$$

## 2.2. Band-pass filtering & instantaneous phase demodulation

The method that is used for comparison of the MOPA method on the experimental data is fairly straightforward and is mainly based on using an ideal band-pass filter around a well-separated, high SNR harmonic of the rotation speed. After defining the optimal lower and upper cutoff frequencies for the band-pass filter, the harmonic is filtered out of the complex spectrum and translated around zero frequency. Next, the complex band-pass filtered spectrum is inverse Fourier transformed to the time domain. The angle is then unwrapped of the complex signal after addition of the demodulation frequency to obtain the instantaneous phase. Finally, the instantaneous angular speed is estimated based on the phase variation.

### 3. Experimental applications

The two methods described above are investigated on two data sets containing vibration measurements of wind turbine gearboxes. The first data set originates from the diagnosis contest held in light of the International Conference on Condition Monitoring of Machinery in Non-Stationary Operations (CMMNO) in 2014. The second data set was recorded as well on the gearbox housing of a wind turbine but due to confidentiality agreements, the authors cannot disclose the origin of the data.

#### 3.1. CMMNO 2014 diagnosis contest data

The vibration signal used for this analysis was measured on the gearbox housing of a wind turbine near the epicyclic gear train and sampled at 20 kHz. The goal was to estimate the IAS of the high-speed shaft (carrying gear #7 in Fig.1). This estimate was then compared with a reference speed signal measured by an angle encoder. The length of the measurement was approximately 550 seconds.

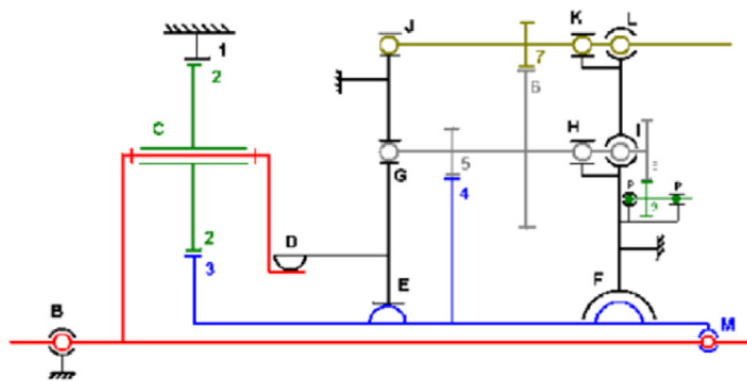

**Figure 1.** Visualization of the wind turbine gearbox used in the CMMNO 2014 diagnosis contest.

In the first step a spectrogram is generated using a rectangular window with a window length of 0.5 seconds, 1.5 seconds of zero padding, and an overlap of 0.25 seconds. Figure 2a displays the resulting spectrogram, in which there are some clear resonances (*red horizontal lines*) to be seen. Therefore the spectrogram is whitened to remove these resonances as is shown in Fig.2b.

The next step is the generation of the pdfs for every meshing order and combining them in order to obtain a single pdf representing the most likely frequency of the IAS. The result of this operation can be seen in Fig.3a. A total of six meshing orders are exactly known and each of them increases the performance of the MOPA method. The last step is to introduce the continuity condition, which performs a smoothing of the pdfs and significantly improves the results as can be seen in Fig.3b.

Now that the pdfs are constructed, the expected value is extracted for every time step. The result of the IAS estimation of the MOPA method and the band-pass filtering method is shown in Fig.4a. For the latter method, the second harmonic of the rotation speed was chosen as the best candidate for demodulation. Additionally, the IAS was only estimated for windows of around 50 seconds at a time for this method, since otherwise the speed variation would be too large. The relative errors of the MOPA method and the band-pass filtering method to the reference signal are displayed in Fig.4b. The error of the MOPA method is significantly smaller, while the band-pass filter sometimes fails to track the actual speed of the signal.



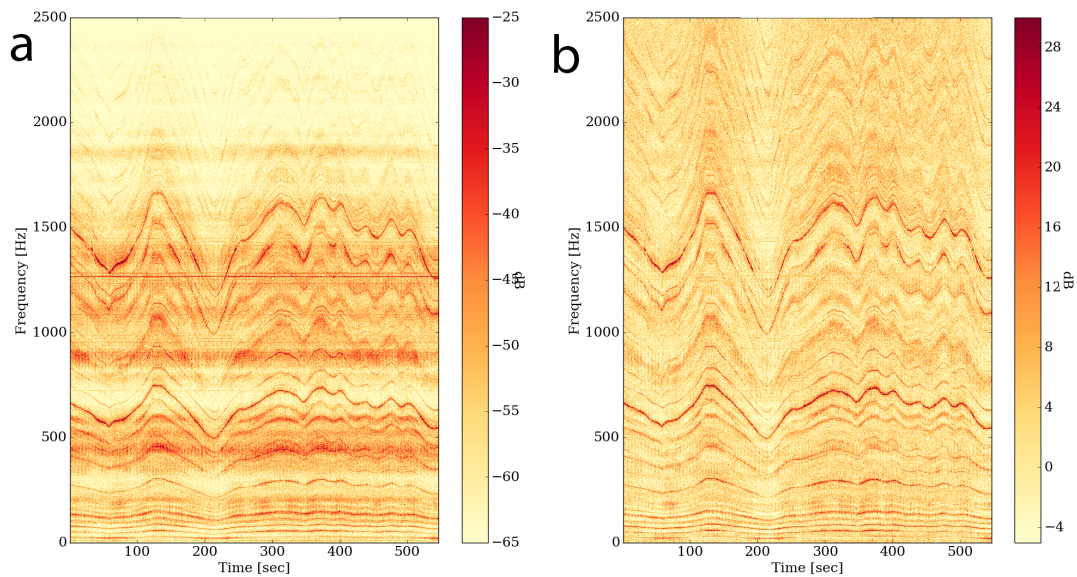

**Figure 2.** (a) Spectrogram of the CMMNO 2014 vibration signal of the wind turbine gearbox housing. (b) Whitenened spectrogram

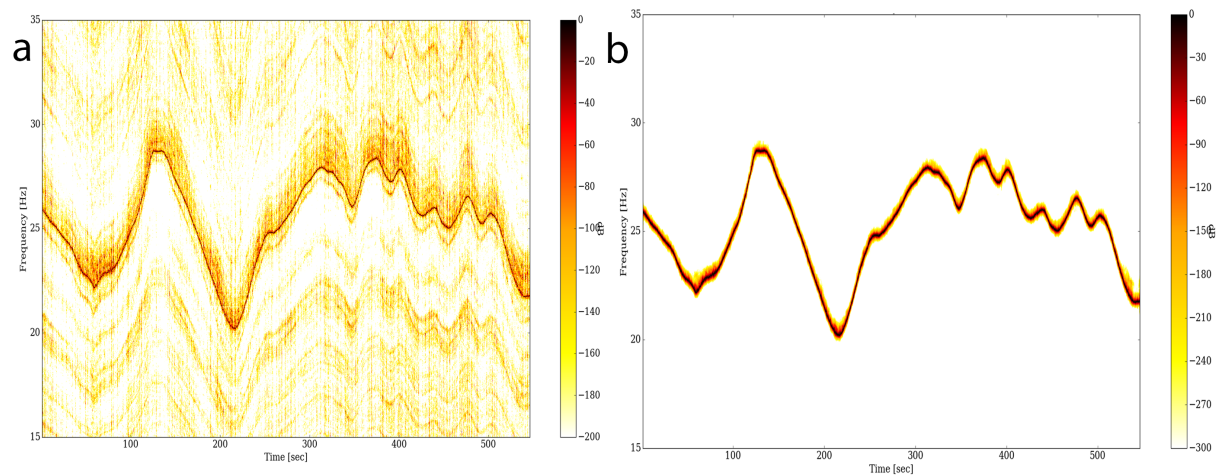
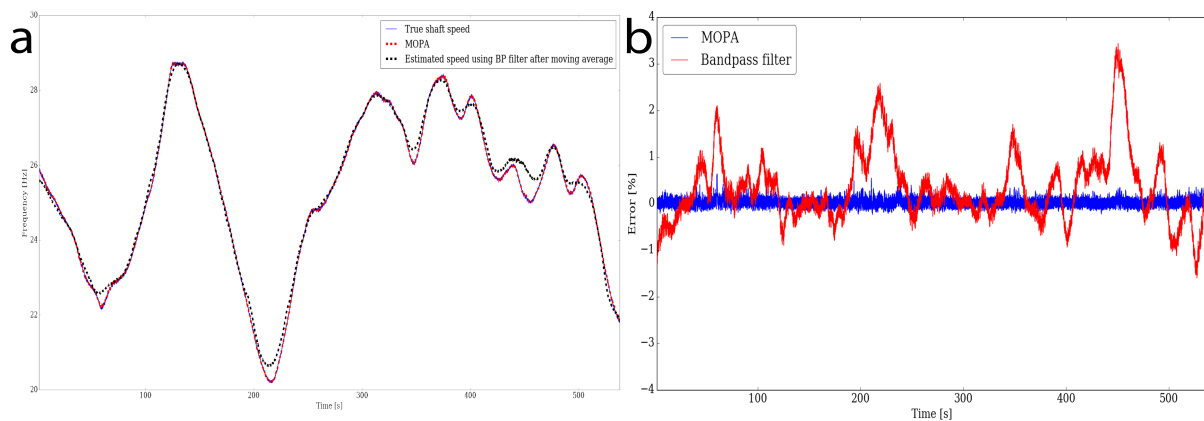

**Figure 3.** (a) Time-Frequency map of the pdfs for an IAS range from 15 to 35 Hz after combining the information of all meshing orders. (b) Time-Frequency map of the pdfs after the a priori continuity introduction.

### 3.2. Second wind turbine gearbox case study

To assess the performance of the MOPA method further, the vibration data of another wind turbine gearbox is investigated. Due to a confidentiality agreement however, no details can be given about the wind turbine itself and some of the certain frequency axes are normalized from zero to one in the figures.

In contrast to the previous case, the exact meshing orders present in the system are not known, which forms quite a significant obstacle for the MOPA method since its main input is these meshing orders. However, the spectrogram can be used for estimating the approximate



**Figure 4.** (a) Comparison of the estimated IAS obtained through MOPA and band-pass filtering to the reference speed signal. (b) Relative error (in %) of the two described methods.

meshing orders and is used for this analysis.

The same procedure as in the previous section is followed. First, the spectrogram is generated and whitened as is shown in Fig.5a & Fig.5b. The spectrogram clearly exhibits two harmonics (around 0.35 and 0.7 normalized frequency) that have an increased amplitude due to their presence near a structural resonance of the system. These harmonics are also linked to the fundamental rotation speed (33<sup>rd</sup> and 66<sup>th</sup> harmonic) of the high-speed shaft and thus form ideal candidates for band-pass filtering and for inclusion in the MOPA method. It is noted that for the meshing order input to the MOPA method only five meshing orders were used and they are all harmonics of the rotation speed, namely the 1<sup>st</sup>, 2<sup>nd</sup>, 3<sup>rd</sup>, 33<sup>rd</sup> and 66<sup>th</sup> harmonic.

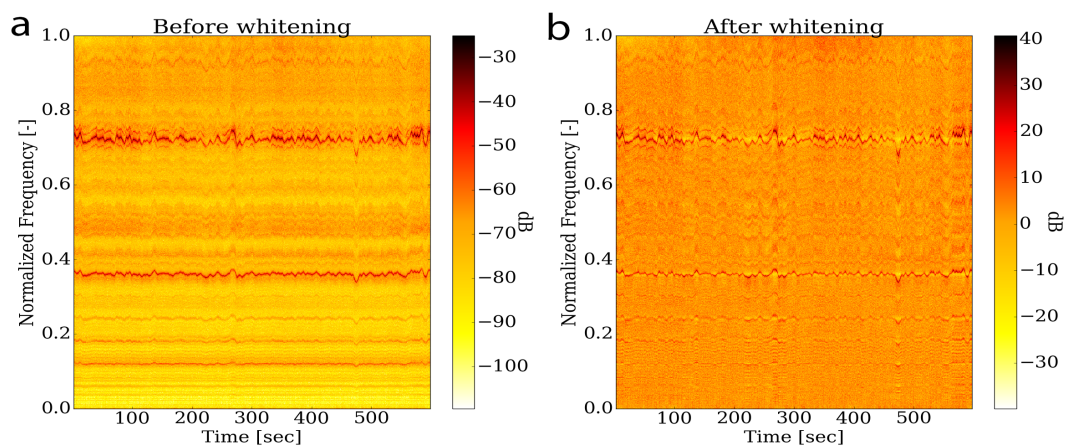
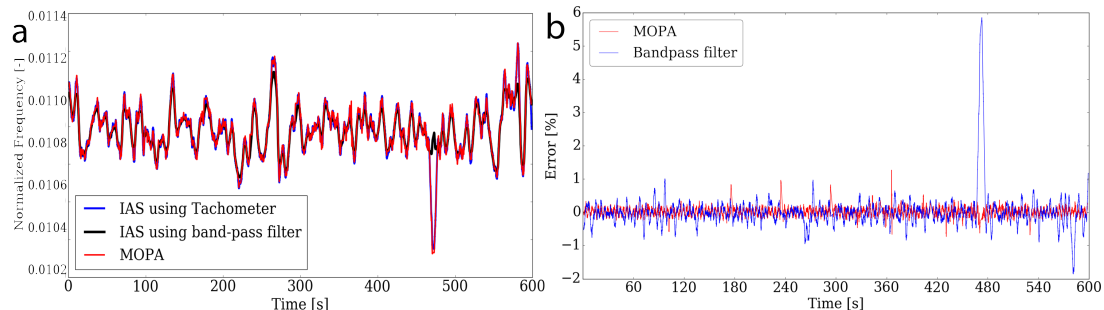

**Figure 5.** (a) Spectrogram of a wind turbine gearbox vibration signal. (b) Whitened spectrogram.

Figure 6a shows the resulting speed profiles obtained with the MOPA method and through using a band-pass filter around the 33<sup>rd</sup> harmonic. The blue line displays the reference speed signal which was measured using a tachometer. Both methods fare quite well in tracking the actual reference speed, but it can be seen that around 470s there is a large deviation in speed



that the band-pass filter is unable to capture. This is also evidenced in the relative error, shown in Fig.6b.



**Figure 6.** (a) Comparison of the estimated IAS obtained through MOPA and band-pass filtering to the reference speed signal. (b) Relative error (in %) of the two described methods.

#### 4. Discussion & Conclusions

This paper investigates the effectiveness of the multi-order probabilistic approach (MOPA) for estimating the instantaneous angular speed of rotating shafts in wind turbine gearboxes. A brief overview of the theory behind the method is presented in section 2. The method is compared to the commonly used band-pass filtering and phase demodulation approach. Two experimental data sets are examined. The first data set originates from the contest held for the CMMNO 2014 conference and consists of vibration data measured on the wind turbine gearbox housing. The probabilistic approach performs very well in tracking the speed fluctuations for the 10 minute signal. The band-pass filtering approach however has to be limited to processing only 50 seconds at once, since the speed variation is too large in some parts of the signal making it exceed the band-pass limits. Even when taking into account block processing for the band-pass filtering approach, care still has to be taken in making sure that no interfering content crosses the demodulation band. The error of the MOPA method compared to the reference signal is significantly smaller in this case than the one for the second approach. The second case however presents a bigger challenge for the MOPA technique. Since the meshing orders of the system are not exactly known, they have to be derived from the spectrogram which makes it difficult to estimate very accurately these ratios. Additionally the presence of a dominant harmonic due to its vicinity to a resonance and the lack of any interfering content in this frequency band makes this a very well-suited data set for the band-pass filter approach. The results corroborate this and show that both methods have a fairly low discrepancy compared to the reference signal. Even though the vibration signal in this case is more suited towards the band-pass filtering method, the MOPA approach performs equally well and does not show large deviations for sudden speed fluctuations. The multi-order probabilistic approach thus presents itself as a robust and easy to use method for speed estimation of rotating machinery. It manages to perform adequately in low SNR scenarios and with very limited input. More knowledge about the system benefits the MOPA approach as it is able to incorporate this information to improve its estimation process, while other methods generally focus on only part of this information and thus do not use its potential.

#### 5. Acknowledgment

The authors are grateful for the provided data by the CMMNO 2014 Organization Committee. They would also like to thank VLAIO for the support through the VIS-OWOME project.

## 6. References

- [1] Helsen J, Guo Y, Keller J and Guillaume P 2016 *Wind Energy* **19** 22552269
- [2] Helsen J, Devriendt C, Weijtjens W and Guillaume P 2016 *Renewable Energy* **85** 259–272
- [3] Blanco M I 2009 *Renewable and Sustainable Energy Reviews* **13** 1372–1382
- [4] Vold H and Leuridan J 1993 High resolution order tracking at extreme slew rates, using kalman tracking filters Tech. rep. SAE Technical Paper
- [5] Stephens D B and Vold H 2014 *Journal of Sound and Vibration* **333** 3818–3830
- [6] Shao H, Jin W and Qian S 2003 *IEEE Transactions on Instrumentation and measurement* **52** 754–761
- [7] Aller J M, Habetler T G, Harley R G, Tallam R M and Lee S B 2002 *IEEE Transactions on Industry Applications* **38** 1344–1350
- [8] Bonnardot F, El Badaoui M, Randall R, Daniere J and Guillet F 2005 *Mechanical Systems and Signal Processing* **19** 766–785
- [9] Randall R and Smith W 2016 *PHM Europe conference, Bilbao, Spain*
- [10] Leclere Q, André H and Antoni J 2016 *Mechanical Systems and Signal Processing* **81** 375386