



HAL
open science

Understanding and managing shared projects in SMEs networks

Cl Villarreal, Lionel Dupont, Didier Gourc, Hervé Pingaud

► **To cite this version:**

Cl Villarreal, Lionel Dupont, Didier Gourc, Hervé Pingaud. Understanding and managing shared projects in SMEs networks. Collaborative Networks and Their Breeding Environments, Sep 2005, Valence, Spain. pp.205-216, 10.1007/0-387-29360-4_21 . hal-01591966

HAL Id: hal-01591966

<https://hal.science/hal-01591966>

Submitted on 25 Sep 2017

HAL is a multi-disciplinary open access archive for the deposit and dissemination of scientific research documents, whether they are published or not. The documents may come from teaching and research institutions in France or abroad, or from public or private research centers.

L'archive ouverte pluridisciplinaire **HAL**, est destinée au dépôt et à la diffusion de documents scientifiques de niveau recherche, publiés ou non, émanant des établissements d'enseignement et de recherche français ou étrangers, des laboratoires publics ou privés.

UNDERSTANDING AND MANAGING SHARED PROJECTS IN SMEs NETWORKS

Carmen L. Villarreal L., Lionel Dupont, Didier Gourc, Hervé Pingaud
Centre de Génie Industriel, Ecole des Mines d'Albi-Carmaux, Albi, France
e-mail address: villarre@enstima.fr

This research work presents a management framework applied to a network of SMEs which organizes its production like a shared project. Starting from a set of network definitions and considering the collective nature of their activities and the concentration on the own core competences, the study tries to specify what is expected from the management. Then, it proposes a framework to plan and manage the collaborative work using concepts coming from project and risk management theories and practices based on the results of an empirical study in a twelve SMEs network from the aeronautical sector located in Toulouse, France. A specific typology of risks that affect the operation of networks is proposed. Additionally, work planning recommendations are presented.

1. INTRODUCTION

Virtual enterprise concepts have gained considerable relevance in the last years. The virtual enterprise is founded in cooperation between independent enterprises that accept a temporary aggregation of all or part of their resources in order to achieve a specific goal, such as a business opportunity for example.

A distinctive feature of these organizations is the large spectrum of life duration. It could be a limited cooperation because a virtual enterprise is legitimated by particular common objectives and should be dissolved subsequently as soon as the objectives have been attained or are considered as not reachable. But it can also be composed of entities linked in long-term alliances such as in supply chains, when products exchanged by partners are of strategic nature with a high added value.

Enterprise networks are considered as a form of virtual enterprise. They could be classified depending on the size of the different members involved in the cooperation. Agreement could be done between a set of large companies, or between large companies and small- and medium-sized enterprises (SMEs), or only SMEs. This work deals with these last organizations, a set of relatively small companies, that decide to share some objectives. This field of investigation implies short or middle term life-cycles of the network, and the management should be quickly efficient and cannot mobilize too much energy and resources.

The study is limited to production SMEs networks which manage their collaborative work as a shared project. Each company preserves individual activities out of the collective project. The network production is executed by many firms, each one is responsible for a part of the whole set of operational activities. So, if

classical project management theory and practice could certainly be applied to the shared project, by definition, sources of uncertainty are always more difficult to handle in such organizations, and risk management is emphasized by the need to react. Reactivity has to be rapidly included in the planning phase of project design. That is the reason why integration of risk to project management appears to this work as a key factor to conceive the management framework.

If many authors have discussed the strategic goals of SMEs networks, there are relatively few references dealing with tactical and operational management levels in such organizations. Unfortunately, if these management levels of networks have some similarities with the ones of a single enterprise, coordination of collective activities in a network at least leads to consider some adaptations and recommendations.

The goal of this work is to search the main features of a network management framework based on project management. The framework is realized from an empirical study in a twelve SMEs manufacturing network from the aeronautical sector, located in Toulouse, France. The study consisted in analyzing project documentation and developing interviews with project managers. The proposition is based on the results of this study.

This paper initially examines the main organizational characteristics of SMEs networks including advantages and restrictions that collective structure comes up to the SMEs. The paper then proposes a global structure and procedure for management including risk analysis and describes a risk typology developed. Finally, a set of recommendations for work planning is presented.

2. SMEs NETWORKS

2.1 Characteristics of SMEs networks

From an organizational point of view, SMEs networks are structures of independent firms related by vertical or horizontal agreements that jointly define a strategy to achieve some goals (Hammami *et al.*, 2004). Different types of networks can be identified according to the pursued objectives (Burlat, 2001): purchasing networks (economies of scale for purchases and supplies), production networks (joint production, product diversification, cost savings), new market oriented networks (sharing business services to increase the turnover), quality certification networks (sharing quality experts to obtain ISO certification), data exchange standardization networks (constructing and adopting common norms to exchange data), etc. These types of networks are not mutually exclusive. For example, a given network may have a strategy composed by both production and purchasing goals.

From an economical point of view, SMEs networks can be considered as particular organizations due to their hybrid form between market and hierarchy. In fact, network coordination is not carried out through a hierarchical organization (as in the firm) or through price regulation mechanisms (as on the market), but through cooperation and free interaction between independent firms (Hammami *et al.*, 2004). The robustness of the network is based on the win-to-win nature of the relationship with respect to individual performances and some autonomy to take decisions.

In the ideal case, partners are only able to develop new businesses and to acquire new competences together, by sharing technology, commercial structure, market locations, productions volumes, resources, skills or activities (Fischer, 2004). But to

transform this strategic goal into real performances, some collaborative processes are necessary in order to affect resources properly, to communicate information correctly and to control the progress of realized work as well as to globally supervise the real investment of partners. It is vital to effectively keep the status of an hybrid organization by maintaining a consensus in the win-to-win game using collaborative processes.

2.2 Benefits and limitations

The pressure to face competitive challenges considerably increases, especially for SMEs, in order to secure their own survival. This also explains the reason for the high frequency of production networks in practice. The main benefits for SMEs in joining manufacturing networks are (Mallidi *et al.*, 1999):

- access to new markets by realizing products that are out of feasibility for the sole SME;
- increased productivity, by cumulating and optimizing the individual collective capacity;
- improved reactivity through joint response to perturbations that would be unbearable for the single enterprise;
- improved utilization of resources, by avoiding duplication of functions through the network.

Network emergence is favored by the intrinsic SMEs lean and flexible structure and, for most of them, by natural disposition toward cooperation, gained through stable subcontracting and partnership links (Mallidi *et al.*, 1999) (Burlat *et al.*, 2001). Nevertheless, the main obstacles to network emergence are the individualistic nature of SME management, the lack of contractual frameworks for these new forms of cooperation and the lack of suitable methods and tools for distributed production management.

Organizing this kind of development effort also poses significant challenges. Extensive reliance on virtual interaction makes it difficult to develop a basic operating structure and set of ground rules to get things up and running (Kovacs *et al.*, 2003).

Moreover, in the course of their work, participants will meet regularly and may iterate some of the decision-making processes in order to achieve consensus by conflict resolution, to anticipate expected disturbances by preventive actions, or to delete perturbation effects using an accepted corrective treatment. Such issues like supervision, re-organization, costs, or re-working, and timely resolution of these issues will be crucial because delay in any subsystem has the potential to delay and undermine work on any other (Adler *et al.*, 1999).

Research indicates that consensus and conflict resolution are especially difficult in time-limited virtual contexts (Maznevski *et al.*, 2000). For such reasons, networks need specific coordination tools to link together activities processed by different firms and to federate independent goals.

Moreover, there are a number of factors which militate against SMEs network project management:

- in comparison to large organizations, SMEs are generally less formal and 'scientific' in their organizational and managerial practices;

- many SMEs have less sophisticated capabilities and expertise than large companies;
- SMEs tend to have a shorter term focus, on medium term survival rather than on long term profit;
- SMEs commonly have fewer resources available, both financial and intellectual (and specially managerial), to invest in major initiatives and are dubious about the benefits of committing those resources to the painstaking planning, data gathering, reporting and analysis that larger organizations would consider essential to such undertakings;
- there is often a degree of reluctance among SMEs managers and owners to use complex computational systems and a tendency to await meaningful pressure from a major client as the necessary stimulus for implementation.

3. THE PROPOSED MANAGEMENT FRAMEWORK

3.1 Procedure modeling requirements

Many of the manufacturing SMEs networks observed organize their common production like a shared project: a complete set of activities and operations which must be carried out by the network in a definite time. In consideration of the above conditions, the operational management framework is defined as a procedure to organize the global process to coordinate activities into the production network in terms of cost, quality and delay time (short-term performance constraints) and to supervise directly the project development. The main problem consists in integrating those kinds of objectives in a unique coherent and collaborative procedure.

In the networks, partner firms are heterogeneous and structured according to a wide range of different organizations. As a consequence of their specific competences and resources, firms' offers are also largely heterogeneous. And normally, the competences' set of the network determines the offers and the type of projects and products (complexity and volume) that the network can develop. In a general way, two types of networks can be found in accordance with the competences of the firms involved (Burlat, 2001). Then, the networks can be composed of firms with similar competences and firms with complementary competences.

At first, the observations about networking lead to accept the following characteristics of work interactions in the networks.

If one considers a network involving firms with similar competences:

- a) The same activity (or task) of the product development can be assigned to several enterprises and then realized with different performances. This kind of events occurs when the project objective is the augmentation of the production volume.
- b) The total product development could be done in projects organized in a parallel way (with identical starting and ending dates).

If one considers a network involving firms with complementary competences:

- a) Different activities are assigned to the firms, when the project objective is to develop a complex product that demands a set of different competences, that any firm involved in the network individually possesses.

- b) The activities could be developed in a project organized in a sequential way (with links of precedence between tasks).

3.2 Project and risk management issues

The conventional methods of project control are based on what has already taken place, i.e. so-called historical information. They use trends to predict future events. Using trends, it is difficult to perceive unforeseeable changes or situations that are surprising or develop outside the scope of project plans.

All such conventional methods adhere to the principle of so-called deviation management. The situation becomes even worse if the project manager is willing to take action only after observing large deviations, such as delays of several weeks in a time management report.

However, the environment in which projects are developed has become increasingly characterized by turbulence relating market and economical pressures. This turbulence emphasizes more and more the possibility of appearance of unforeseeable events. This possibility is included in the concept of risk (Courtot, 1998). In this study, the risk is considered like the possibility of occurrence of events which could be threats or opportunities (Bakir *et al.*, 2002) (Jaafari, 2001).

The need of taking risks into account on project management was largely recognized (Miller *et al.*, 2001) (Ward *et al.*, 2003)] and it is considered like a pertinent operational answer. In the particular case of shared projects in SMEs networks, uncertainty increases because of common work organization, the multiplicity and heterogeneity of partners and the resource sharing (Peillon, 2001). Compared to traditional cooperation styles, there are more uncertain factors in a network (Li *et al.*, 2004).

While the network brings a lot of flexibility to partners, it also implies some unavoidable risks. For example, in the operation process of network, the core technologies of an enterprise will intentionally and unconsciously pass on to other member partners, which are likely to become competitors. In contract design process, it is inevitable that there are some ambiguous items, which are likely to result in the profit conflicts among partners and so on. In order to operate the network and achieve anticipated goal, it is necessary to know all kinds of risk factors that influence the operation of network and, furthermore, take appropriate measures to prevent and control them. Implementing the risk analysis process in network project organization could make sure the risk responsibility will be shared by the partners, help member enterprises to avoid bad cooperative relations and make network operate in lower cost and risk.

3.3 The global procedure proposed and the related structure

Because of the increasing cooperation between SMEs in so-called production networks, new concepts for the management of value chains need to be developed. Apart from the operational application of information technology realized so far, which only serves the optimization of the enterprise-internal processes (O'Sullivan, 2003), global management of networks needs to optimize the whole value chain in order to make sure that all the participants have the possibility to act successfully on the market.

According to discussed aspects and adapting different approaches such as the ones of Martinez (Martinez *et al.*, 2001) about virtual enterprise organization and Mezgár (Mezgár *et al.*, 2000) about cooperative production, the model proposes a

non-hierarchic structure in a collaborative environment to systematize the project development and control using risk analysis which could be applicable to the two configurations of networks mentioned above. A network management board usually assumes the general organization of the whole process, and particularly management, planning and quality, but to manage all these activities, procedures and interfaces have to be precisely defined, and a large investment in time and work is needed.

This could end up in a large system, which has many chances to be non-flexible, or with a chaotic one, where leadership and organization problems will appear. Then, at first a structure which must be linked to the procedure and that could make the general system more flexible is proposed (see Figure 1). This structure is composed of two project decision levels:

1. The Network Management Board (NMB), which will be in charge of strategic aspects of shared projects: the project decomposition in global process, evaluation of feasibility, negotiation, project refinement, establishment of the contract and the provisional planning. The actors of this Network Management Board must be representative of each firm and linked to network activities (normally, this structure exists already since the creation of the network). They must have the capacity to take strategic decisions (“go” or “no-go”) and to financially engage their own enterprise.
2. The Project Management Board (PMB), which must supervise and control all the project phases (planning, procurement, delivery and site activity). It has to be composed of actors linked directly to shared project development in each enterprise.

And in relation to the operational management (including supervision and control) of the shared project, the approach is based on Project Management and Risk Management techniques.

Firstly, this approach will be based on initial planning carried out by the Network Management Board. A first risk identification action could be developed. Because at this time, aspects of the project may not be clearly defined, the identification may be applied as a purely qualitative approach if it is to test the viability of a new project, but if it is being used to assess budgets or bid prices, a quantitative approach may be required.

Secondly, a process of synchronization project/risk could be applied. This process is founded on the coexistence of the project planning process and risk management process. It explains the integration of methods and the information exchange between those two processes.

The Project Management Board can start the risk analysis process by identifying and evaluating possible events (risks). This identification-evaluation phase must allow to know:

- where the risk comes from, in terms of what effects might be experienced, and the mechanisms underlying these effects;
- what it could be done about it, in proactive and reactive response terms (risk mitigation).

In the third place, the PMB can organize information to begin the construction of a new planning taking risks into account. The objective of this step is to identify possible disturbances on initial planning caused by risks and to transform this planning by adding representation of alternative activities (the realization of these activities is conditioned by the appearance of anticipated events).

Afterwards, they can generate possible scenarios (taking risks into account) using a planning tool and simulating different manners of carrying out the project. In

this way, the PMB team has project performance indicators integrating the identified risks and their possible effects.

The step of follow-up makes it possible to collect information while the project is in progress. If any of the anticipated events occurs, PMB could start a new risk analysis phase. So, the iterative nature of the work in the network meeting is naturally supported by an iterative feature of risk processes management. These new information elements lead the PMB to define and to insert new tasks and new decisions in project planning.

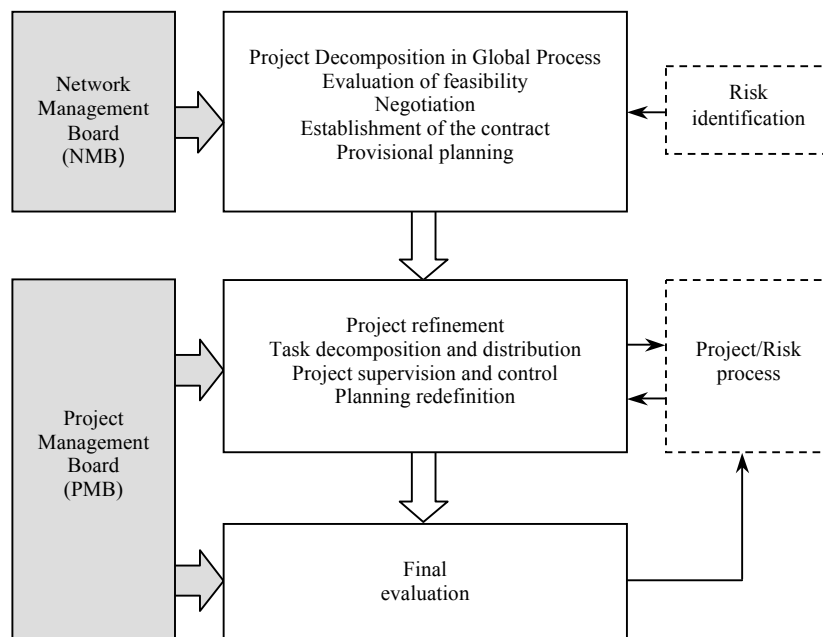

Figure 1: The proposed management procedure and related structure.

In total, this proposed work procedure allows the Project Management Board to deal with limitations related to inter-organizational nature of the common project because many scenarios are studied in order to solve effective problems and decisions are taken knowing the impact of each one on project performance.

At last, a final evaluation must be done to generate the necessary report and to obtain information about project development, modifications of initial planning and the occurrence of unforeseen events.

Thus, the total life cycle of a network, since the formation phase, is full of various risks. Then, it is recommended to implement some strategies of risk analysis in other aspects of network life such as policy definition, finance management, market analysis, competences organization, cooperation issues, operation and so on. The responsible of this monitoring would be the NMB.

3.4 Definition of risk typology

Further to the premises presented above of making risk monitoring of global aspects of the network and iterative risk analysis during project development, the initial set

of risks is classified depending on the way a possible event is linked to network composition, organization and networking, external environment and the project internal processes.

As far as risk analysis is concerned, the study found that observations conforming to the idea of risk can be frequently made in project activity environments. The risk typology developed during this phase of research (presented in Table 1) indicates that the risks are observed to occur in all project phases, deliver information on all parts of the project, and show themselves in many ways with various sources: human ones, documents and situations.

This investigation also found that many project actors are already familiar with the existence of risk and they make use of these indicators in some unstructured and often unconscious way.

Table 1 - The description of risk typology

Risk domain	Risk factors
Structure	Selection of partners Partners relationship Size of partners Competences of partners
Organization	Strategic policies Marketing policies Financial procedures Established structure and role distribution <i>Know-how</i> capitalization Co-operative culture
External environment	Competitiveness Suppliers/Subcontractors Clients Public policies
Project internal processes	Collaborative planning Resources allocation and management Technical asymmetries Global project control

The main task of typology construction was to recognize all kinds of risk factors by analyzing a great deal of reliable information data. They not only include those obvious factors but also include those potential factors, which may be more difficult to identify. Otherwise, the domain concerns activities or entities associated with risk manifestation and identified as risk factors.

The first three domains correspond to risks associated to network characteristics and dynamics (that eventually could have influence in project) and the last domain presents the risks linked directly to project organization and development. This typology could be considered as a referential to risk identification. Periodic and continuous actions of risk analysis and the final evaluation of project could enrich and modify it.

3.5 Risk mitigation

One of the challenges of risk analysis and management is to find effective actions to deal with the possibility of events occurrence. If the risk is a menace that could have

negative effects, preventive actions could be implemented. On the other hand, if risk involves an opportunity, managers could contemplate some actions to take hold of it.

For example, as it has been said, one of the principal features of networks is the heterogeneity of partner structure and offers due to their specific competences and resources. The selection of a new partner could pose problems about competence compatibility of candidate in relation to global competence configuration of network. Then, one way to anticipate this kind of problems is to develop a detailed competence cartography of the network and also to meticulously evaluate the competences of possible partners to envisage their positioning in network configuration.

Another situation in network dynamics could be the absence of a defined framework for financial collective issues that could create cash flows problems. To anticipate, an accurate procedure could be developed and contractualised.

An example of project environment could be the difference between the technical performances of each partner when they develop a product that could have a negative impact in global performance. Such kind of situation could be treated with anticipation by establishing training around specific technical aspects or information exchange about practices and experiences lived in order to mitigate knowledge asymmetries.

3.6 Work planning recommendations

Each company is self-organized while the network's common structure is in charge of the global communication, the management of shared project and synchronization between activities. Projects undertaken by the SMEs networks are, by nature, decomposable in relatively independent sub-projects.

Then, at this phase, it is necessary to find the best combination of project decomposition and task allocation and to submit the answer to customer in the shortest process time. In a network structure this process can be achieved with the help of different methods and approaches (Martinez *et al.*, 2001).

First, the product could be decomposed according to its functions and analysis of each function cost is then carried out. Afterwards, the product technologies and design could be selected and with this information, the processes to develop the product and their cost could be deduced.

Sometimes, realizing successive processes decomposition to determine a set of tasks in which every task can be entirely assigned to a single organization by the network is needed.

The system cannot handle every elementary task. The PMB will have control on activities which are composed by these elementary tasks. These tasks are managed by the internal organization of each of the shared projects' actors, that means, the firms.

The product, the information procedure and protocols as well as the plan for process control must be distributed and utilized on the management systems of the partner firms. A task is locally managed by the responsible in the firm according to its own method and organization.

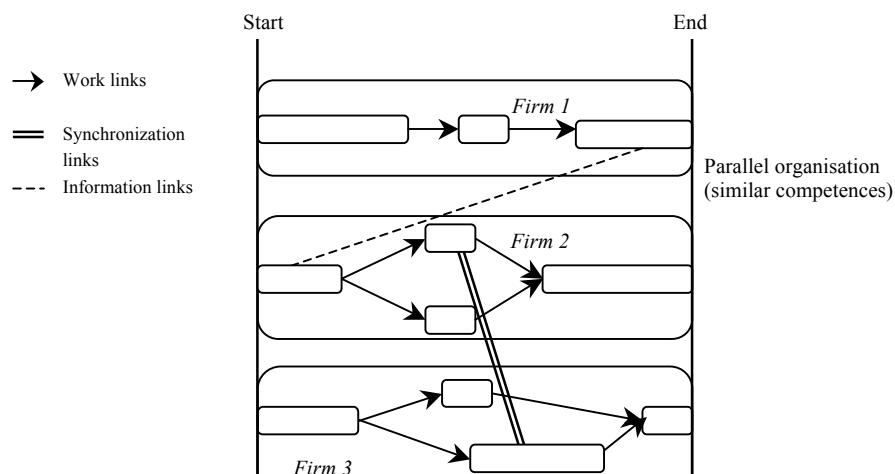

Figure 2. Task links

A distribution of task control among the network structure and the structure of partner firms should be achieved, as follows. The management of allocated tasks (task allocated as a whole to a firm) is assumed by the PMB. The following information must be defined for each allocated task:

- the synchronicity of tasks (a typical example of synchronization needs could be common purchases or tests of materials);
- the information needed and associated exchange procedures (the posterior assemblage of two pieces developed by different firms could be a reason to exchange information);
- the precedence links of tasks.

Both the case of a parallel organization of tasks (when similar competences are involved) and the case of sequential organization (when firms have complementary competences) can apply to these prescriptions (see Figure 2).

Nevertheless, the latter could become more difficult due to the complexity of decomposition and allocation of the task involved. To define this information, the firm in charge of a task must collaborate with the firms in charge of the previous or simultaneous ones. The collaborative work, which is difficult to manage at the network's global level, is made by the PMB.

4. CONCLUSIONS

SMEs networks is an emergent concept in manufacturing. The first objective of this paper was to present a management model that includes a global vision of the structure and an operational procedure centered in the organization of the common production.

The model presented proposes a possible answer to methods of project management in relation to shared projects in multi-organizational taking the network's short-term dynamics into account: real time constraints and risks.

The study hopefully adds elements that were previously known to project management, but not really treated. The realization of the risk analysis will contribute to anticipate events and to enrich a specific risk typology for shared projects in SMEs networks.

Anticipating problems and opportunities can make the decision-making process agile. In the particular case of SMEs networks, the organizational problems of shared projects linked to multiplicity (and heterogeneity) of the actors (partners) can be approached according to this *ex-ante* vision.

Moreover, one of the characteristics of virtual organizations such as the SMEs networks is time limitations that make a more dynamic, flexible and convenient decision-making process necessary.

These needs can be satisfied by the iterative and continuous character of the model proposed which can make a contribution to conventional methods of project management relating to shared projects.

In addition, project planning and task link definition in inter-firm projects could contribute to organizing project control.

Finally, this research work is the first part of a French regional SMEs development project (Midi-Pyrénées Région, France). This project is initiating cross research to support SMEs networks' creation and to assure their continuity.

5. REFERENCES

1. Adler P, Goldoftas B, Levine D. Flexibility versus efficiency? A case study of model changeovers in the Toyota production system. *Organization Science* 1999; 10(1): 43-69.
2. Bakir S, Gourc D, Pingaud H. Les méthodes de planification de projet en univers risque: apports et limites. Actes du 5^{ème} Congrès International Franco-Québécois de Genie Industriel, Québec: Université de Laval, 2002.
3. Burlat, Patrick. GRECOPME II: Groupements d'Entreprises Coopérantes, Potentialités, Moyennes et Evolutions. Rapport de recherche. France: Ecole des Mines de Saint Etienne, 2001.
4. Burlat P, Boucher X. Pilotage distribué des groupements d'entreprises. Modélisation et perspectives. *Journal Européen de Systèmes Automatisés* 2001; numéro spécial.
5. Courtot, Hervé. La Gestion des Risques dans les Projets. Paris: Economica, 1998.
6. Fischer M, Jähn H, Tobias T. Optimizing the selection of partners in production networks. *Robotics and Computer-Integrated Manufacturing* 2004; 20: 593-601.
7. Hammami A, Burlat P, Campagne J.P. Evaluating orders allocation within networks of firms. *International Journal of Production Economics* 2003; 86(3): 233-249.
8. Jaafari, Ali. Management of risks uncertainties and opportunities on projects: time for a fundamental shift. *International Journal of Project Management* 2001; 19: 89-101.
9. Kovacs GL, Paganelli P. A planning and management infrastructure for large, complex, distributed projects –beyond ERP and SCM. *Computers in Industry* 2003; 51: 165-183.
10. Li Y, Liao X. Decision support for risk analysis on dynamic alliance. *Decision Support Systems* 2004; article in press.
11. Mallidi K, Paraskevopoulos AT, Paganelli P. Process modelling in small-medium enterprise networks. *Computer in Industry* 1999; 38: 148-158.

12. Martinez MT, Fouletier P, Park KH, Favrel J. Virtual enterprise – organisation, evolution and control. *International Journal of Production Economics* 2001; 74: 225-238.
13. Maznevski ML, Chudoba KM. Bridging space over time: global virtual team dynamics and effectiveness. *Organization Science* 2000; 11(5): 473-492.
14. Mezgár I, Kovacs GL, Paganelli P. Co-operative production planning for small- and medium-sized enterprises. *International Journal of Production Economics* 2000; 64: 37-48.
15. Miller R, Lessard D. Understanding and managing risks in large engineering projects. *International Journal of Project Management* 2001; 19: 437-443.
16. O'Sullivan, Alan. Dispersed collaboration in a multi-firm, multi-team product-development project. *Journal of Engineering and Technology Management* 2003; 20: 93-116.
17. Peillon Sophie. Le pilotage des coopérations interentreprises: le cas des groupements de PME. Thèse de Doctorat. France: Université Jean Monnet, 2001.
18. Ward S, Chapman C. Transforming project risk management into project uncertainty management. *International Journal of Project Management* 2003; 21: 97-105.