



HAL
open science

3D Modeling of Coils for Pulsed Field Magnetization of HTS Bulk Pellets in an Electrical Machine

Kévin Berger, Jakub Kapek, Alexandre Colle, Mariusz Stepień, Bogusław Grzesik, Thierry Lubin, Jean Lévêque

► **To cite this version:**

Kévin Berger, Jakub Kapek, Alexandre Colle, Mariusz Stepień, Bogusław Grzesik, et al.. 3D Modeling of Coils for Pulsed Field Magnetization of HTS Bulk Pellets in an Electrical Machine. IEEE Transactions on Applied Superconductivity, 2018, 28 (4), pp.6801205. 10.1109/TASC.2018.2804906 . hal-01590665v2

HAL Id: hal-01590665

<https://hal.science/hal-01590665v2>

Submitted on 8 Feb 2018

HAL is a multi-disciplinary open access archive for the deposit and dissemination of scientific research documents, whether they are published or not. The documents may come from teaching and research institutions in France or abroad, or from public or private research centers.

L'archive ouverte pluridisciplinaire **HAL**, est destinée au dépôt et à la diffusion de documents scientifiques de niveau recherche, publiés ou non, émanant des établissements d'enseignement et de recherche français ou étrangers, des laboratoires publics ou privés.

3D Modeling of Coils for Pulsed Field Magnetization of HTS Bulk Pellets in an Electrical Machine

Kévin Berger, Jakub Kapek, Alexandre Colle, Mariusz Stepień, Bogusław Grzesik, Thierry Lubin, and Jean Lévêque

Abstract—In this work, we propose to study and design a coil used to magnetize, by means of a Pulsed Field Magnetization (PFM) process, an inductor of a radial flux superconducting machine with one pair of poles. Each pole contains four similar HTS bulks of 30 mm diameter arranged in a square pattern. The cryostat already exists for this application and the temperature of the HTS bulks can vary from 4.2 K to their critical temperature, in transient state. For a given primary source of energy, here a capacitor bank of 10 kJ (5 mF, 2 kV) is available, the PFM process depends strongly on the value of the coil inductance used to generate pulsed field, because it defines the waveform of the current: peak value and time constant. Thus, 3D modeling of the coil is required in order to be sure that its inductance and the magnetic field produced will provide a full magnetization of HTS bulks. From the practical point of view, we would like to achieve an average magnetization of each pole around 3 T.

In this paper, numerical modeling of coils with different number of turns coupled with circuit's equations is achieved. The maximum magnetic field obtained on the HTS bulks and estimated magnetization at the top center of each HTS bulk, are presented and discussed.

Index Terms—Bulk conductors, Inductance, Modeling, Pulse measurements, Superconducting rotating machines, Very high field and NMR magnets.

I. INTRODUCTION

THE DEVELOPMENT of cryo-magnets based on REBaCuO bulk superconductors, that can generate up to 17 T [1], [2], gives the opportunity to see a technological breakthrough in electrical engineering developments. The key point to provide such development is the integration of the magnetization system including coils used to produce the magnetic field applied to the superconducting materials. Currently, the most convenient way to magnetize a High Temperature Superconducting (HTS) bulk is to use a pulsed magnetic field. This method is called PFM for Pulsed Field Magnetization [3], [4]. It can generate strong magnetic fields while using a relatively compact and simple coil. Thus, HTS bulks can be directly magnetized into the final application.

To the best of our knowledge, only a few teams have realized superconducting motors with HTS bulks acting as permanent magnets. As an example, the axial gap-type motor designed and realized in Japan can be mentioned here [5], [6]. This machine

The authors would like to acknowledge the "Région Lorraine" for its financial support. Jakub Kapek would like to thanks the Erasmus+ program for the funding of his internship in Nancy.

Kévin Berger, Jakub Kapek, Alexandre Colle, Thierry Lubin and Jean Lévêque are with the Group of Research in Electrical Engineering of Nancy, Faculty of Sciences and Technologies, University of Lorraine, 54 506 Vandoeuvre-lès-Nancy, France (e-mail: name.surname@univ-lorraine.fr).

has been changed over the years to include now a double rotor and triple armatures [7], [8]. As another example, a radial type motor has also been realized in UK [9]. The stator consists of six air-core HTS armature windings and the rotor is made of 75 HTS bulks (15 columns, 5 pieces per column) mounted on surface and to be magnetized as a four-pole permanent magnet. [10]–[13]. All realized motors involving HTS bulks as permanent magnets have shown a trapped magnetic field by the HTS bulks lower than 1 T. Therefore, the magnetization of the HTS bulks is still one of main scientific and technical challenge in such applications with the main goal to obtain a trapped magnetic flux density by the HTS bulks greater than 3 T [7], [14].

The analysis of electromagnetic, thermal and mechanical stresses on HTS bulks has not been studied in this paper. These difficult issues are the subject of recent studies started by means of numerical simulations [15], [16], and some experimental validations are underway.

Therefore, this paper deals with the design of the coils needed to magnetize HTS bulk pellets acting as the inductor of a superconducting electrical machine. The next section is devoted to present and describe the studied motor and to the foreseen specifications of the used coils. In Section III, the description of the 3D numerical model used to design the PFM coils is given, as well as the obtained results.

II. MOTOR'S DESCRIPTION

The activities of the GREEN laboratory are mainly dedicated to the possible applications of superconductivity in electrical engineering. In 2014, a new configuration of superconducting motor called "magnetic flux barrier motor" has been successfully designed and tested in the lab [17]–[20]. This motor, as shown in Fig. 1, has the particularity to include an inductor mounted inside a stationary cryostat and a rotating armature outside the cryostat.

The realization of a radial-type motor with magnetized HTS bulks acting as the inductor, is the next project of the GREEN, starting in October 2017. It was decided to keep the armature

Alexandre Colle is also with SAFRAN TECH., 78 114 Magny-les-Hameaux, France.

Mariusz Stepień and Bogusław Grzesik are with the Silesian University of Technology, Department of Power Electronics, Electrical Drives, 44-100 Gliwice, Poland.

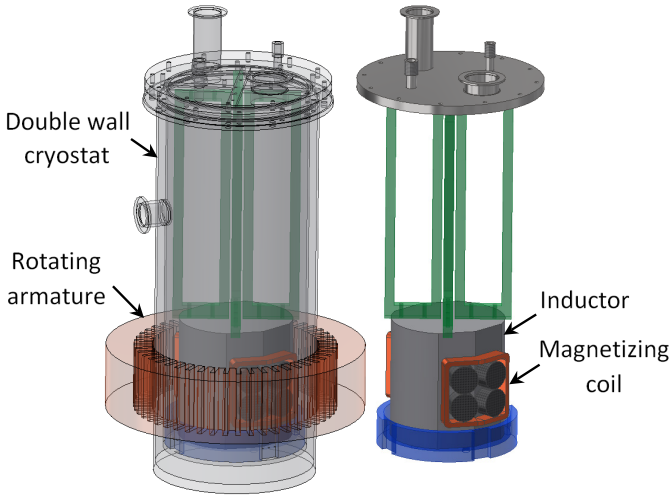

Fig. 1. Preliminary 3D drawings of the studied electrical machine.

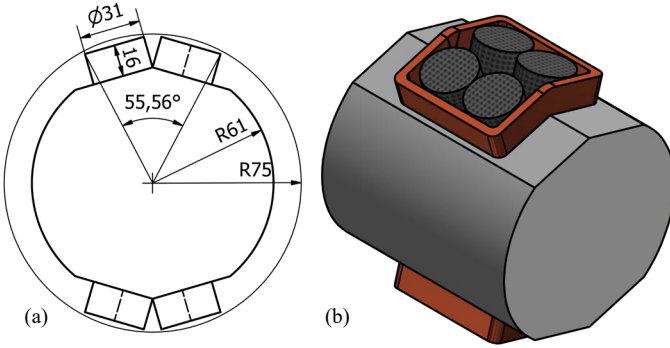

Fig. 2. Cross-sectional drawing of the inductor with given dimensions in mm (a) and a 3D isometric view with the magnetizing coils visible (b).

and cryostat of the previous motor, in order to avoid any extra cost.

A. Description of the inductor

The inductor will consist of one-pole pairs as shown in the previous realization. Each pole set contains four HTS bulks mounted on a square pattern and supposed to undergo the pulsed magnetization. We planned to use melt textured YBCO bulks from ATZ GmbH [21] or Can Superconductors [22]. These pellets are 16 mm high with a diameter of 31 mm and they can trap a maximal magnetic flux density of approximately 1.2 T at 77 K [22].

A cross-sectional drawing of the inductor including bulk pellets is shown in Fig. 2 (a), as well as a 3D isometric view in Fig. 2 (b). Some geometrical parameters of the motor are also given in Table I.

B. Description of the impulse magnetizer

In a previous experiment, it was possible to use a homemade setup with a bank of 24 capacitors with a total capacitance value of 80 mF and voltage up to 300 V [23]. This setup, which also includes a thyristor, can withstand peak currents up to 15 kA. Recently, the lab acquired an impulse magnetizer from Magnet-Physik [24]. Here are the main technical characteristics: 10 kJ of stored energy, a capacitance of 5 mF, charging up to 2 kV, a peak surge current of 20 kA and a non-repetitive peak current of 35 kA.

TABLE I
SOME GEOMETRICAL PARAMETERS OF THE MOTOR

Symbol	Quantity	Value
R_{cyl}	radius of the ferromagnetic cylinder of the inductor	61 mm
R_{ind}	overall radius of the inductor including the HTS bulks	74 mm
e_1	mechanical air gap between the inductor and the cryostat	1 mm
R_{inn}	inner radius of the cryostat	75 mm
e_2	overall thickness of the cryostat	12 mm
R_{out}	outer radius of the cryostat	87 mm
e_3	mechanical air gap between the armature and the cryostat	2 mm
R_{arm}	inner radius of the armature	89 mm
e_r	total air gap between the inductor and the armature	15 mm
L_{arm}	active length of the armature	70 mm

These parameters are used in the next section to design the coil required to achieve the simultaneous magnetization of the four HTS bulks of one or both poles set, at the same time.

III. DESIGN OF THE MAGNETIZING COIL

A. Description of the electrical system

The equivalent electrical diagram of the impulse magnetizer system is given in Fig. 3. Once the capacitors are fully charged, the impulse current starts to flow in the magnetizing coil once the thyristor is switched on by the gate terminal. The time evolution of this current is governed by the RLC circuit parameters, for instance, the capacitance C , the initial charge voltage of the capacitors U_{c0} , the resistance R_{mc} and the inductance L_{mc} of the magnetizing coil, the remaining resistance R_λ and inductance L_λ of the RLC circuit, e.g. cables.

All the mentioned parameters above are known except those of the magnetizing coil. The resistance R_{mc} depends on the operating temperature of the coil and we assume that this temperature will never be higher than 100 K before starting the PFM process. At higher temperatures, the increase of the coil resistance leads to decrease drastically the peak current generated by the impulse magnetizer. The inductance L_{mc} of the coil is shown as variable element in Fig. 3 because its value is non-linear due to the presence of the ferromagnetic and superconducting materials.

One of the difficulties arising in the design of the magnetizing coil is that the current waveform and therefore, the maximum value of the magnetic field applied to the HTS bulks, depend on the non-linear inductance L_{mc} .

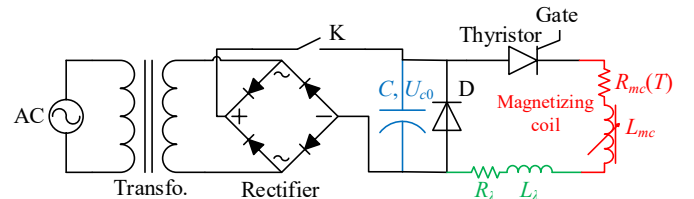

Fig. 3. Equivalent electrical diagram of the impulse magnetizer system used to magnetize HTS bulks.

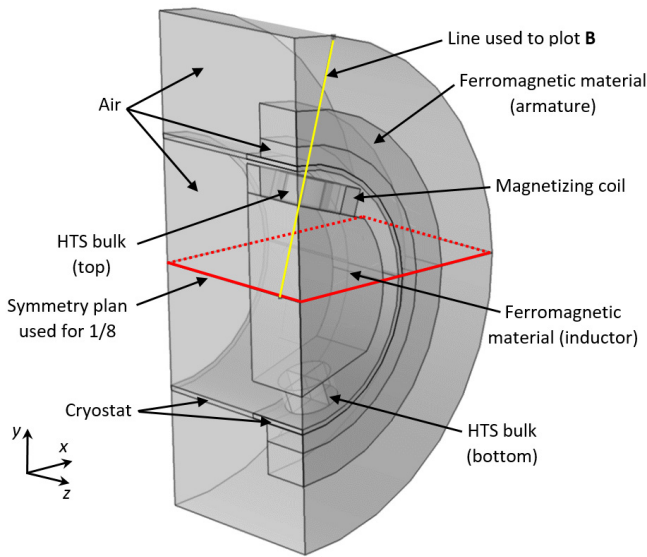

Fig. 4. 3D Geometry of the studied problem (1/4 of the geometry).

B. 3D modeling of the magnetization of the inductor

Since the magnetizing coil's geometry is three-dimensional and non-linear, the only way to design this coil is to use a numerical software. The widely used software, in particular by our research team in such studies, is the COMSOL® Multiphysics software [25]. It allows us to compute 3D electromagnetic problems using the *magnetic field physics* package and to couple the equations with the RLC circuit shown in Fig. 3.

In previous works, coils have successfully been realized for magnetizing one single HTS pellet by using copper foils of 0.2 mm or 0.5 mm thickness, and the same width as the HTS bulk height [23]. The coils to be modelled in the present study, will respect the same criteria. Kapton tape of 25 μm thick is used between turns for insulation purpose. In order to optimize the magnetic flux produced by one pole, we have decided to design a single coil around the 4 HTS bulks of one pole instead of one coil around each bulk.

The inductor shown in Fig. 2 is made from a cobalt iron cylinder VACODUR® 50 [26] including eight HTS bulks. Due to the symmetries, if we have to magnetize the four bulks of one pole, only a quarter (1/4) of the geometry is needed to achieve the simulation. If both poles are magnetized at the same time, symmetries lead to study 1/8 of the full geometry. Therefore, the studied problem with 1/4 of the geometry is shown in Fig. 4. On the basis of these choices, parametric simulations have been carried out for a number of turns between 18 and 28.

The current waveform for an initial capacitor voltage of 2 kV is shown during the magnetization of one single pole in Fig. 5(a) and for both poles in series in Fig. 5(b). For 18 turns, the corresponding maximum current values I_{max} obtained during the magnetization of one pole and both poles, are respectively: 16.69 kA and 11.97 kA. In both cases, the I_{max} value is still acceptable for the components of the electrical circuit. The decrease of the peak current is mainly due to the increase of the inductance of the coil when both coils are connected in series. Therefore, increasing the number of turns N leads to a decrease of I_{max} .

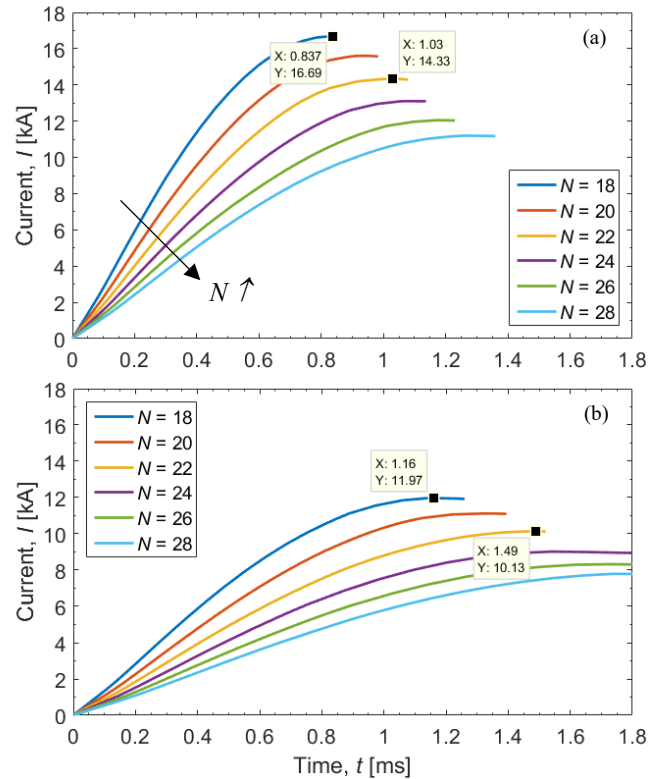

Fig. 5. Impulse current in the magnetizing coil for an initial capacitor voltage of 2 kV, during the magnetization of one single pole (a), and for both poles in series (b).

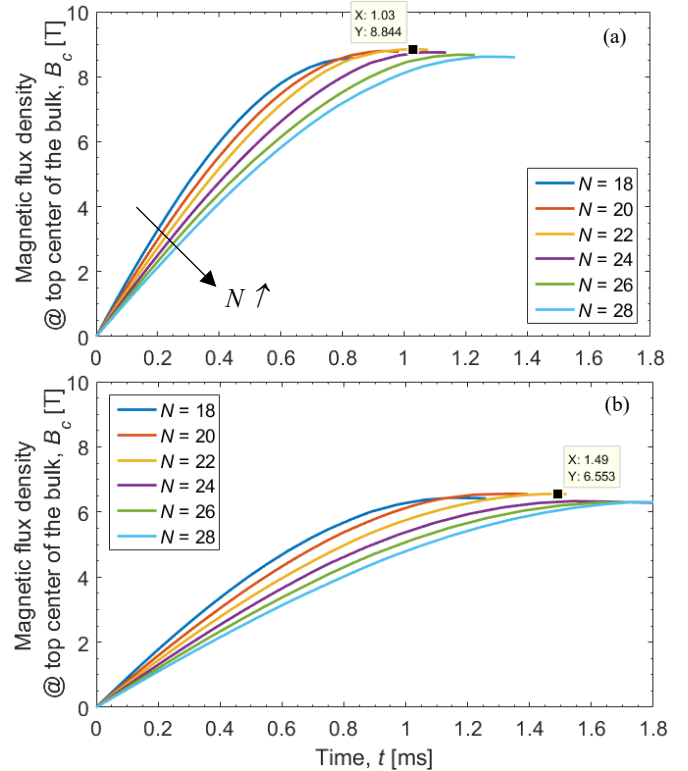

Fig. 6. Norm of the magnetic flux density B_c at the top center of one HTS bulk, for an initial capacitor voltage of 2 kV, during the magnetization of one single pole (a), and for both poles in series (b).

Fig. 6 shows the norm of magnetic flux density B_c at the top center of one HTS bulk, during the magnetization of one single pole in Fig. 6(a), and for both poles in series in Fig. 6 (b). For

both configurations, there is an optimal value of magnetic flux density that we can apply to the HTS bulks. This maximum value of B_c is obtained for 22 turns, while 20 turns give a very similar value. A maximum applied flux density of 8.844 T at the top center of the HTS bulk is obtained at 1.03 ms, corresponding to a peak current of 14.33 kA, when one single pole is magnetized (see Fig. 6(a)). This maximum applied flux density is strongly decreased down to 6.553 T if both poles are magnetized simultaneously, as is shown in Fig. 6(b). Indeed, if both magnetizing coils are connected in series, the inductance increases which leads to a decrease of the peak current. For information purpose, the calculated inductance of one coil at 5 ms is 79.7 mH compared to 167.3 mH for both coils in series, almost twice as much, which means that there are not well coupled. Based on those results, and assuming a Bean's critical state model for the HTS bulks, a maximum trapped magnetic flux density around 4.4 T, half of the maximum applied magnetic flux density, seems to be a manageable target.

Finally, the norm of the magnetic flux density and flux lines at the maximum current with $N=22$ are shown for the magnetization of one pole in Fig. 7 and the magnetization of both poles in Fig. 8. The magnetic field distribution in the xOy plane at the middle of the HTS bulk are reported in Fig. 7(a) and Fig. 8(a), whereas Fig. 7(b) and Fig. 8(b) show the magnetic field distribution in the xOy plane at $x=0$. Fig. 7 and Fig. 8 give us the information about flux leakage and magnetic flux density amplitude in the whole inductor. The maximum magnetic flux density observed in Fig. 7 is around 18.3 T instead of 13.3 T in Fig. 8, while the flux lines crossing the air gap observed in Fig. 7 are much more numerous than obtained ones in the case shown by Fig. 8.

IV. CONCLUSION

The optimal design of a magnetizing coil for an inductor of a superconducting electrical machine with one pair of poles set of four HTS bulks each, has been achieved. The resulting coil consists of 22 turns of copper foil wound around the four pellets of each pole. The peak current of 14.33 kA is obtained at 1.04 ms with produced magnetic flux density up to 8.844 T at the top center of the HTS bulk. From the practical point of view, to obtain the maximum magnetic flux density applied to the HTS bulk, the best process is to magnetize each pole one by one. Finally, we can expect a trapped magnetic flux density by the HTS bulks around 4.4 T, which is a promising value compared to a state of the art in motors applications. The modelled magnetizing coil and the inductor in the present work, will be built during the next months and experimental results will give us confidence about the achievable trapped magnetic flux density for such application.

ACKNOWLEDGMENT

The authors would like to thank Rachid Dadi from VACUUMSCHMELZE GmbH for providing us with the VACODUR 50 material, and Salah Eddine Bentriddi for the English proofreading of the final version of the paper.

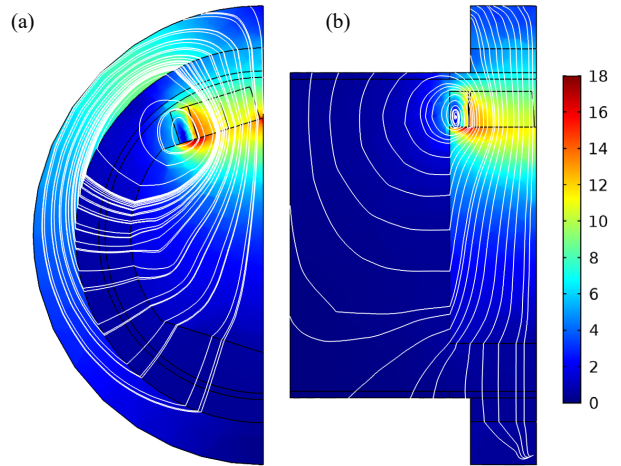

Fig. 7. Norm of the magnetic flux density in Tesla, and flux lines during the magnetization of one single pole with $N=22$ at 1.03 ms, i.e. maximum current: in the xOy plane at the middle of the HTS bulk (a) and in the yOz plane $x=0$ (b).

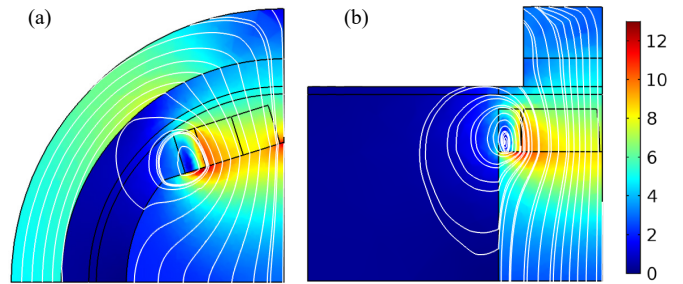

Fig. 8. Norm of the magnetic flux density in Tesla, and flux lines during the magnetization of both poles with $N=22$ at 1.49 ms, i.e. maximum current: in the xOy plane at the middle of the HTS bulk (a) and in the yOz plane $x=0$ (b).

REFERENCES

- [1] J. H. Durrell *et al.*, "A trapped field of 17.6 T in melt-processed, bulk Gd-Ba-Cu-O reinforced with shrink-fit steel," *Supercond. Sci. Technol.*, vol. 27, no. 8, p. 082001, 2014.
- [2] M. Tomita and M. Murakami, "High-temperature superconductor bulk magnets that can trap magnetic fields of over 17 tesla at 29 K," *Nature*, vol. 421, no. 6922, pp. 517–520, Jan. 2003.
- [3] U. Mizutani, T. Oka, Y. Itoh, Y. Yanagi, M. Yoshikawa, and H. Ikuta, "Pulsed-field magnetization applied to high-Tc superconductors," *Appl. Supercond.*, vol. 6, no. 2, pp. 235–246, Feb. 1998.
- [4] H. Fujishiro, T. Tateiwa, A. Fujiwara, T. Oka, and H. Hayashi, "Higher trapped field over 5T on HTSC bulk by modified pulse field magnetizing," *Phys. C Supercond. Its Appl.*, vol. 445, pp. 334–338, Oct. 2006.
- [5] H. Matsuzaki *et al.*, "An axial gap-type HTS bulk synchronous motor excited by pulsed-field magnetization with vortex-type armature copper windings," *IEEE Trans. Appl. Supercond.*, vol. 15, no. 2, pp. 2222–2225, Jun. 2005.
- [6] M. Miki *et al.*, "Development of a synchronous motor with Gd–Ba–Cu–O bulk superconductors as pole-field magnets for propulsion system," *Supercond. Sci. Technol.*, vol. 19, no. 7, p. S494, 2006.
- [7] Y. Zhang, D. Zhou, T. Ida, M. Miki, and M. Izumi, "Melt-growth bulk superconductors and application to an axial-gap-type rotating machine," *Supercond. Sci. Technol.*, vol. 29, no. 4, p. 044005, 2016.
- [8] H. Matsuzaki *et al.*, "HTS Bulk Pole-Field Magnets Motor With a Multiple Rotor Cooled by Liquid Nitrogen," *IEEE Trans. Appl. Supercond.*, vol. 17, no. 2, pp. 1553–1556, Jun. 2007.
- [9] Q. Jiang, M. Majoros, Z. Hong, A. M. Campbell, and T. A. Coombs, "Design and AC loss analysis of a superconducting synchronous motor," *Supercond. Sci. Technol.*, vol. 19, no. 11, p. 1164, 2006.

- [10] Z. Hong, W. Yuan, M. Ainslie, Y. Yan, R. Pei, and T. A. Coombs, "AC Losses of Superconducting Racetrack Coil in Various Magnetic Conditions," *IEEE Trans. Appl. Supercond.*, vol. 21, no. 3, pp. 2466–2469, Jun. 2011.
- [11] W. Xian, Y. Yan, W. Yuan, R. Pei, and T. A. Coombs, "Pulsed Field Magnetization of a High Temperature Superconducting Motor," *IEEE Trans. Appl. Supercond.*, vol. 21, no. 3, pp. 1171–1174, Jun. 2011.
- [12] Z. Huang, M. Zhang, W. Wang, and T. A. Coombs, "Trial Test of a Bulk-Type Fully HTS Synchronous Motor," *IEEE Trans. Appl. Supercond.*, vol. 24, no. 3, pp. 1–5, Jun. 2014.
- [13] Z. Huang, H. S. Ruiz, W. Wang, Z. Jin, and T. A. Coombs, "HTS Motor Performance Evaluation by Different Pulsed Field Magnetization Strategies," *IEEE Trans. Appl. Supercond.*, vol. 27, no. 4, pp. 1–5, Jun. 2017.
- [14] K. Berger *et al.*, "High Magnetic Field Generated by Bulk MgB₂ Prepared by Spark Plasma Sintering," *IEEE Trans. Appl. Supercond.*, vol. 26, no. 3, pp. 1–5, Apr. 2016.
- [15] F. Trillaud, K. Berger, B. Douine, and J. Leveque, "Distribution of current density, temperature and mechanical deformation in YBCO bulks under Field-Cooling magnetization," *IEEE Trans. Appl. Supercond.*, vol. PP, no. 99, pp. 1–1, 2018.
- [16] K. Takahashi, H. Fujishiro, T. Naito, Y. Yanagi, Y. Ito, and T. Nakamura, "Numerical simulation of electromagnetic and thermal stress in RE-BaCuO superconducting ring and disk bulks reinforced by stainless steel ring with various widths during field-cooled magnetization," *IEEE Trans. Appl. Supercond.*, vol. PP, no. 99, pp. 1–1, 2018.
- [17] R. Alhasan *et al.*, "Study of a superconducting motor with high specific torque," in *MEA 2015 More Electric Aircraft*, Toulouse, France, 2015, p. 91.
- [18] R. Alhasan, T. Lubin, Z. M. Adilov, and J. L  v  que, "A New Kind of Superconducting Machine," *IEEE Trans. Appl. Supercond.*, vol. 26, no. 3, pp. 1–4, Apr. 2016.
- [19] R. Alhasan, T. Lubin, B. Douine, Z. M. Adilov, and J. L  v  que, "Test of an Original Superconducting Synchronous Machine Based on Magnetic Shielding," *IEEE Trans. Appl. Supercond.*, vol. 26, no. 4, pp. 1–5, Jun. 2016.
- [20] M. Kelouaz *et al.*, "3D Magnetic field modeling of a new superconducting synchronous machine using reluctance network method," *Phys. C Supercond. Its Appl.*, vol. 548, pp. 5–13, May 2018.
- [21] F. Werfel, "Adelwitz Technologiezentrum GmbH," *ATZ*, 11-May-2016. [Online]. Available: <http://www.atz-gmbh.com/>. [Accessed: 11-May-2016].
- [22] "CSYL-35 YBCO Levitation Disk - CAN SUPERCONDUCTORS e-shop." [Online]. Available: http://shop.can-superconductors.com/index.php?id_product=15&controller=product. [Accessed: 08-Sep-2017].
- [23] B. Gony, K. Berger, B. Douine, M. R. Koblischka, and J. Leveque, "Improvement of the Magnetization of a Superconducting Bulk using an Iron Core," *IEEE Trans. Appl. Supercond.*, vol. 25, no. 3, pp. 1–4, Jun. 2015.
- [24] "MAGNET-PHYSIK Dr. Steingroever GmbH: Impulse Magnetizer." [Online]. Available: <http://www.magnet-physik.de/impulsmagnetisierer.html?L=1>. [Accessed: 09-Sep-2017].
- [25] K. Berger *et al.*, "Benchmark on the 3D Numerical Modeling of a Superconducting Bulk," in *21st International Conference on the Computation of Electromagnetic Fields (Compumag 2017)*, Daejeon, South Korea, 2017, p. (ID 110).
- [26] "VACODUR - Magnetic Properties - VACUUMSCHMELZE GmbH & Co. KG." [Online]. Available: <http://www.vacuumschmelze.com/en/products/materials-parts/soft-magnetic/cobalt-iron/vacodur/vacodur-magnetic-properties.html>. [Accessed: 16-Sep-2017].