



**HAL**  
open science

## Multivariate juggling probabilities

Arvind Ayyer, Jérémie Bouttier, Sylvie Corteel, François Nunzi

► **To cite this version:**

Arvind Ayyer, Jérémie Bouttier, Sylvie Corteel, François Nunzi. Multivariate juggling probabilities. 25th International Conference on Probabilistic, Combinatorial and Asymptotic Methods for the Analysis of Algorithms (AofA 2014), Jun 2014, Paris, France. pp.1-12. hal-01587381

**HAL Id: hal-01587381**

**<https://hal.science/hal-01587381v1>**

Submitted on 14 Sep 2017

**HAL** is a multi-disciplinary open access archive for the deposit and dissemination of scientific research documents, whether they are published or not. The documents may come from teaching and research institutions in France or abroad, or from public or private research centers.

L'archive ouverte pluridisciplinaire **HAL**, est destinée au dépôt et à la diffusion de documents scientifiques de niveau recherche, publiés ou non, émanant des établissements d'enseignement et de recherche français ou étrangers, des laboratoires publics ou privés.

# Multivariate juggling probabilities

Arvind Ayyer<sup>1</sup> and Jérémie Bouttier<sup>2</sup> and Sylvie Corteel<sup>3</sup> and François Nunzi<sup>3†</sup>

<sup>1</sup>*Department of Mathematics, Indian Institute of Science, Bangalore - 560012, India*

<sup>2</sup>*Institut de Physique Théorique, CEA, IPhT, 91191 Gif-sur-Yvette, France, CNRS URA 2306 and*

*Département de Mathématiques et Applications, École normale supérieure, 45 rue d'Ulm, F-75231 Paris Cedex 05*

<sup>3</sup>*LIAFA, CNRS et Université Paris Diderot, Case 7014, F-75205 Paris Cedex 13. Corresponding author: F. Nunzi  
fnunzi@liafa.univ-paris-diderot.fr*

**Abstract.** We consider refined versions of Markov chains related to juggling. We further generalize the construction to juggling with arbitrary heights as well as infinitely many balls, which are expressed more succinctly in terms of Markov chains on integer partitions. In all cases, we give explicit product formulas for the stationary probabilities and closed-form expressions for the normalization factor. We also refine and generalize enriched Markov chains on set partitions. Lastly, we prove that in one case, the stationary distribution is attained in finite time.

**Keywords:** Markov chain, Combinatorics, Juggling

## 1 Introduction

This is an extended abstract of Ayyer et al.. Although juggling as a human endeavour has been around since time immemorial, it is fairly recently that mathematicians have taken an active interest in exploring the field. Combinatorialists became interested in juggling towards the end of the last century after an article by Buhler et al. (1994). Since then, their results have been  $q$ -ified by Ehrenborg and Readdy (1996) and further refined in various ways by Stadler (1997, 2002); Chung and Graham (2007, 2008); Butler and Graham (2010). Further connections between juggling and mathematics appear for instance in algebraic geometry in Devadoss and Mugno (2007); Knutson et al. (2013). A mathematical history of juggling is given in the fascinating book by Polster (2003). Warrington (2005) gave exact combinatorial formulas for the stationary distribution of juggling models. More recently, a  $q$ -deformation of Warrington's original finite model was considered by Engström et al., who also obtained exact expressions for the stationary distribution via an enriched chain formulated in terms of rook placements.

In this paper, we provide multivariate generalizations of all the models introduced in Warrington (2005), namely *juggling*, *add-drop juggling* and *annihilation juggling*. Furthermore, in the case of the juggling model with a conserved number of balls, we investigate the limiting case where balls can be thrown arbitrarily high. We also consider the limiting case where the number of balls tends to infinity. In all these

<sup>†</sup>The authors are partially funded by ANR grants ANR-08-JCJC-0011 and ANR 12-JS02-001-01 and by the projet Émergences Combinatoire à Paris

cases, we obtain an exact formula for the stationary distribution. Our proofs were mainly obtained from two approaches. First, the general formulas can often be guessed, then proved straightforwardly by considering the juggling process itself or its natural reformulation in terms of integer partitions. The other approach is Warrington’s combinatorial approach consisting in introducing an enriched chain whose stationary distribution is simpler, and which yields the original chain by a projection or “lumping” procedure, see e.g. Levin et al. (2009).

The rest of the paper is organized as follows. In Section 2, we concentrate on the simplest version of our model, which we call the Multivariate Juggling Markov Chain (MJMC). The model is defined in Section 2.1, and we also discuss the uniqueness of the stationary distribution. The expression for the stationary distribution of the Markov chain is stated in Section 2.2. A combinatorial proof comes in Section 2.3 and involves set partitions with a prescribed number of elements and blocks. We then turn to extended models. Extensions to infinite state spaces are considered in Section 3 : in Section 3.1, we give an interesting reformulation in terms of integer partitions which will prove useful. The case of a finite number of balls but *unbounded* heights (UMJMC) is discussed in Section 3.2, while the case of an *infinite* number of balls (IMJMC) is considered in Section 3.3. Extensions to a fluctuating number of balls (but with a finite state space) are considered in Section 4 : we provide the multivariate extension of the add-drop and the annihilation models introduced in Warrington (2005), in the respective Sections 4.1 and 4.2. We end with some remarks and questions for future study in Section 5.

Due to space restrictions, most proofs are omitted and we refer the reader to the long version of the paper Ayyer et al. for details.

## 2 The finite Multiparameter Juggling Markov Chain

### 2.1 Definition

In this section, we introduce our juggling model in the simplest setting, i.e. a Markov chain on a finite state space. Consider a person, called *Magnus* with no loss of generality, who is juggling with a fixed finite number  $\ell$  of balls. Time is discretized in steps of one second and we assume that, at each second, Magnus is able to catch at most one ball, and then throws it back immediately. Besides this limitation Magnus juggles *perfectly*, i.e. in a such way that the ball will always return to him after some time. Magnus chooses how long it will take for the ball to return to him. We suppose for now that the number of seconds before the ball returns to Magnus is bounded by an integer  $h$ . Moreover Magnus must choose the successive launches in such a way that no two balls arrive to him at the same time. Thus, treating the balls as indistinguishable, there are  $\binom{h}{\ell}$  possible ball states. It is convenient to think of a state as a configuration of  $\ell$  non overlapping particles on a one-dimensional lattice with  $h$  sites, where the  $i$ -th site (read from the left) is occupied if and only if a ball is scheduled to arrive  $i$  seconds in the future. We denote by  $k = h - \ell$  the number of empty (unoccupied) sites.

In this language, the time evolution of a state is easy to describe: at each time step, all particles are moved one site to the left. If there is no particle on the first site, then nothing else has to be done. Otherwise the particle on the first site is *reinserted* at one of the  $k + 1$  available (empty) sites on the lattice. This defines the transition graph of our model, illustrated on Figure 1 for  $h = 3$ ,  $\ell = 2$  and  $k = 1$ .

We now assume that Magnus juggles at random: each reinsertion is made at the  $i$ -th available site (read from the left) with probability  $x_{i-1}$ , independently of the past, so that our model is a Markov chain. Here,  $x_0, \dots, x_k$  are fixed nonnegative real numbers such that  $x_0 + \dots + x_k = 1$ . This defines the *Multivariate Juggling Markov Chain* (MJMC).

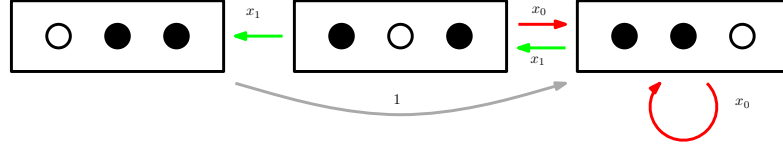

**Fig. 1:** The Markov chain with  $h = 3$  and  $k = 1$ .

We now provide a more formal mathematical definition of the MJMC. Following Warrington's notations, let  $\text{St}_h$  denote the set of words of length  $h$  on the alphabet  $\{\bullet, \circ\}$ , and let  $\text{St}_{h,k} \subset \text{St}_h$  be the subset of such words containing exactly  $k$  occurrences of  $\circ$ . For  $A \in \text{St}_{h,k+1}$  and  $i \in \{0, \dots, k\}$ , we let  $T_i(A) \in \text{St}_{h,k}$  be the word obtained by replacing the  $(i+1)$ -th occurrence of  $\circ$  in  $A$  by  $\bullet$ .

**Definition 2.1** Given  $h, k$  nonnegative integers such that  $h \geq k$ , and  $x_0, \dots, x_k$  nonnegative real numbers such that  $x_0 + \dots + x_k = 1$ , the Multivariate Juggling Markov Chain (MJMC) is the Markov chain on the state space  $\text{St}_{h,k}$  for which the transition probability from  $A = a_1 a_2 \dots a_h$  to  $B$  reads

$$P_{A,B} = \begin{cases} 1 & \text{if } a_1 = \circ \text{ and } B = a_2 \dots a_h \circ, \\ x_i & \text{if } a_1 = \bullet \text{ and } B = T_i(a_2 \dots a_h \circ), \\ 0 & \text{otherwise.} \end{cases} \quad (2.1)$$

**Proposition 2.2** If  $x_0 > 0$ , then the MJMC has a unique closed communicating class, whose all states are aperiodic. If furthermore  $x_k > 0$ , then the MJMC is irreducible.

**Proof:** Easy. Note that, when  $x_0 = 0$ , the chain may have several closed communicating classes (for instance, take  $h = 4$ ,  $k = 2$  and let  $x_0 = x_1 = 0$ ). When  $x_k = 0$ , any state with a particle on site  $h$  is transient.  $\square$

## 2.2 Stationary distribution

From now on we assume  $x_0 > 0$ . By Proposition 2.2, the MJMC admits a unique stationary probability distribution. Our main result is an explicit form for it, given as follows.

**Theorem 2.3** The stationary probability distribution  $\pi$  of the MJMC is given by

$$\pi(B) = \frac{1}{Z_{h,k}} \prod_{\substack{i \in \{1, \dots, h\} \\ b_i = \bullet}} y_{E_i(B)}, \quad (2.2)$$

where  $B = b_1 \dots b_h \in \text{St}_{h,k}$ ,  $E_i(B) = \#\{j < i \mid b_j = \circ\}$ ,

$$Z_{h,k} = h_\ell(y_0, y_1, \dots, y_k) \quad (2.3)$$

with  $h_\ell$  the complete homogeneous symmetric polynomial of degree  $\ell = h - k$ , and where we introduce the shorthand notation

$$y_m = \sum_{j=m}^k x_j, \quad m = 0, \dots, k. \quad (2.4)$$

We will prove in Section 2.3 that  $\pi$  is indeed a stationary distribution of the MJMC. The explicit expression (2.3) for the normalization factor is not difficult to check for instance by induction, by partitioning words in  $\text{St}_{h,k}$  according to their first letter. As specializations, we have in particular

$$\begin{aligned} Z_{h,k}((1-q), (1-q)q, \dots, (1-q)q^{k-1}, q^k) &= \binom{h}{k}_q, & Z_{h,k}(1, 1, \dots, 1, 1) &= \left\{ \begin{matrix} h+1 \\ k+1 \end{matrix} \right\}, \\ Z_{h,k}(q^k, q^{k-1}, \dots, q, 1) &= \left\{ \begin{matrix} h+1 \\ k+1 \end{matrix} \right\}_q, & Z_{h,k}(1, q, \dots, q^{k-1}, q^k) &= q^{k(h-k)} \left\{ \begin{matrix} h+1 \\ k+1 \end{matrix} \right\}_{1/q}, \end{aligned} \quad (2.5)$$

where  $\{\cdot\}$  denotes Stirling numbers of the second kind,  $\{\cdot\}_q$  their  $q$ -analogues as defined in Gould (1961) and  $\binom{\cdot}{\cdot}_q$   $q$ -binomial coefficients.

### 2.3 Enriched Markov chain on set partitions

The purpose of this Section is to prove by a combinatorial argument that the measure  $\pi$  over  $\text{St}_{h,k}$  defined in Theorem 2.3 is indeed a stationary measure of the MJMC. The main idea is to expand the product in the right hand side of (2.2) as a sum of monomials in the  $x_i$ 's, and interpret each of these monomials as the stationary probability of an “enriched” state.

Let us introduce the shorthand notations  $H = h + 1$  and  $K = k + 1$ . An *enriched state* is a partition of the set  $\{1, 2, \dots, H\}$  into  $K$  subsets called *blocks*. We denote by  $\mathcal{S}(H, K)$  the set of enriched states. To each enriched state  $\sigma$ , we associate a word  $\psi(\sigma) = a_1 \dots a_h$  by setting  $a_i = \circ$  if  $i$  is a *block maximum* of  $\sigma$ , and  $a_i = \bullet$  otherwise. Observe that  $\psi$  is a surjection from  $\mathcal{S}(H, K)$  onto  $\text{St}_{h,k}$ . See Figure 2 for an illustration.

We now define the enriched Markov chain on  $\mathcal{S}(H, K)$ . For an enriched state  $\sigma$ , we denote by  $\sigma^\downarrow$  the partition of the set  $\{1, \dots, h\}$  obtained by removing 1 from  $\sigma$ , and shifting all the remaining elements of all blocks down by 1. For  $\tau \in \mathcal{S}(h, K)$  and  $i \in \{0, \dots, k\}$ , we denote by  $I_i(\tau)$  the set partition of  $\{1, \dots, H\}$  obtained by inserting  $H$  into the  $(i + 1)$ -th block of  $\tau$ , where the blocks are numbered by ascending order of their maxima. Note that  $I_i(\tau) \in \mathcal{S}(H, K)$  and that the mapping  $(\tau, i) \mapsto I_i(\tau)$  is injective.

**Definition 2.4** *The enriched chain is the Markov chain on  $\mathcal{S}(H, K)$  for which the transition probability from  $\sigma$  to  $\tau$  is given by*

$$\tilde{P}_{\sigma, \tau} = \begin{cases} 1 & \text{if } \{1\} \in \sigma \text{ and } \tau = \sigma^\downarrow \cup \{H\}, \\ x_i & \text{if } \{1\} \notin \sigma \text{ and } \tau = I_i(\sigma^\downarrow) \text{ for some } i \in \{0, \dots, k\}, \\ 0 & \text{otherwise.} \end{cases} \quad (2.6)$$

The condition  $x_0 + \dots + x_k = 1$  and the above remarks ensure that  $\tilde{P}$  is indeed a (right) stochastic matrix.

**Example 2.5** *For  $H = 8$  and  $K = 3$ :*

- *the enriched state  $1 | 356 | 2478$  jumps with probability 1 to  $245 | 1367 | 8$ ,*
- *the enriched state  $35 | 267 | 148$  jumps with probability:  $x_0$  to  $156 | 37 | 248$ ,  $x_1$  to  $24 | 37 | 1568$ , and  $x_2$  to  $24 | 156 | 378$ .*

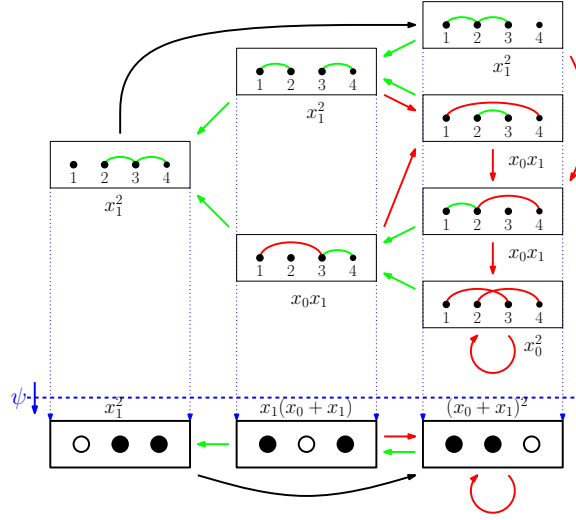

**Fig. 2:** Top: transition graph of the enriched chain for  $H = 4$  and  $K = 2$ . Red, green and grey arrows represent transitions of respective probability  $x_0$ ,  $x_1$  and 1. Bottom: the projection onto the MJMC with  $h = 3$  and  $k = 1$ .

**Example 2.6** For  $H = 4$  and  $K = 2$ , the transition graph of the enriched chain is illustrated on Fig. 2.

The existence and uniqueness of the stationary distribution of the enriched chain results from the following easy proposition.

**Proposition 2.7** For  $x_0 > 0$ , the enriched chain has a unique closed communicating class, whose all states are aperiodic. The chain is irreducible if and only if all  $x_i$ 's are nonzero.

It is not difficult to check that the surjection  $\psi$  introduced above defines a projection of the enriched chain onto the MJMC, compatible with the dynamics. More precisely, let  $\Psi$  be the rectangular matrix with rows indexed by elements of  $\mathcal{S}(H, K)$  and columns indexed by elements of  $\text{St}_{h,k}$  in the obvious manner (namely a coefficient of  $\Psi$  is 1 if its column index is the image by  $\psi$  of its row index, and 0 otherwise), then it is straightforwardly checked that we have the “intertwining property”  $\tilde{P}\Psi = \Psi P$ , see Figure 2 for an illustration. The intertwining property immediately implies that the stationary measures  $\pi$  and  $\tilde{\pi}$  of both chains are related by

$$\pi = \tilde{\pi}\Psi. \tag{2.7}$$

Our route to Theorem 2.3 is now clear. We want to find an explicit expression for  $\tilde{\pi}$ , then compute  $\tilde{\pi}\Psi$ . We first need to introduce some definitions and notations.

**Definition 2.8** Let  $\sigma$  be an enriched state and  $s, t$  two integers such that  $1 \leq s < t \leq H$ . We say that the pair  $(s, t)$  is an arch of  $\sigma$  if  $s$  and  $t$  belong to the same block  $\beta$  of  $\sigma$ , while no integer strictly between  $s$  and  $t$  belongs to  $\beta$ . For  $1 \leq s < t \leq H$ , we denote by  $C_\sigma(s, t)$  the number of blocks containing at least one element in  $\{s, s + 1, \dots, t - 1, t\}$ . When  $(s, t)$  is an arch, we say that these blocks are those covered by  $(s, t)$ .

**Lemma 2.9** For  $\sigma \in \mathcal{S}(H, K)$ , the monomial

$$\tilde{w}(\sigma) = \prod_{(s,t) \text{ arch of } \sigma} x_{K-C_\sigma(s,t)} \quad (2.8)$$

defines an unnormalized stationary measure of the enriched chain.

**Proof:** See again Figure 2 for a proof by example: arches covering 1 or 2 blocks are represented in green or red respectively, and weighting them by respectively  $x_1$  and  $x_0$  indeed yields a stationary measure of the enriched chain. We refer the reader to Ayyer et al. for a formal proof.  $\square$

It is easily seen that there is one set partition in  $\mathcal{S}(H, K)$  whose all arches cover  $K$  blocks, so that

$$Z_{h,k} = \sum_{\sigma \in \mathcal{S}(H,K)} \tilde{w}(\sigma) \quad (2.9)$$

is positive whenever  $x_0 > 0$ , and  $\tilde{\pi} = \tilde{w}/Z_{h,k}$  is the stationary probability distribution of the enriched chain. For  $B \in \text{St}_{h,k}$ , we set

$$w(B) = \sum_{\sigma \in \psi^{-1}(B)} \tilde{w}(\sigma), \quad (2.10)$$

that is  $w = \tilde{w}\Psi$ . Then,  $\pi = w/Z_{h,k}$  is the stationary probability distribution of the MJMC. By considering the possible preimages of  $B = b_1 \dots b_h \in \text{St}_{h,k}$  by  $\psi$ , we find that

$$w(B) = \prod_{\substack{i \in \{1, \dots, h\} \\ b_i = \bullet}} (x_{E_i(B)} + \dots + x_k). \quad (2.11)$$

where  $E_i(B) = \#\{j < i | b_j = \circ\}$  (see Ayyer et al. for details).

**Example 2.10** Returning again to the case  $H = 4, K = 2$  (i.e.  $h = 3, k = 1$ ) illustrated on Figure 2, we find

$$w(\circ \bullet \bullet) = x_1^2, \quad w(\bullet \circ \bullet) = (x_0 + x_1)x_1 = x_1, \quad w(\bullet \bullet \circ) = (x_0 + x_1)^2 = 1. \quad (2.12)$$

This completes the proof that  $\pi$  defined by (2.2) is indeed the stationary distribution of the MJMC.

### 3 Extensions to infinite state spaces

In this section, we mention the possible extensions of the Multivariate Juggling Markov Chain to an infinite setting. This is most conveniently done by reformulating the MJMC in terms of integer partitions, which we do first. All the proofs are skipped, see Ayyer et al..

#### 3.1 Reformulation of the MJMC in terms of integer partitions

There is a natural bijection between  $\text{St}_{h,k}$  and  $\text{Par}_{k,\ell}$  (with  $\ell = h - k$ ), where  $\text{Par}_{k,\ell}$  is the set of integer partitions whose Young diagram fits within a  $k \times \ell$  rectangle. Given  $A$  a state in  $\text{St}_{h,k}$ , we denote by  $s_1 < s_2 < \dots < s_{\ell-1} < s_\ell$  the positions of  $\bullet$  in  $A$ , then the corresponding integer partition is  $(s_\ell - \ell, s_{\ell-1} - (\ell - 1), \dots, s_2 - 2, s_1 - 1)$ . Remark that  $s_i - i$  is equal to the number of  $\circ$  appearing before the  $i$ -th  $\bullet$  in  $A$ . We may reformulate the MJMC as follows.

**Proposition 3.1** For  $\lambda = (\lambda_1, \lambda_2, \dots, \lambda_\ell)$  and  $\mu = (\mu_1, \mu_2, \dots, \mu_\ell)$  two partitions in  $\text{Par}_{k,\ell}$ , the transition probability from  $\lambda$  to  $\mu$  reads

$$P_{\lambda,\mu} = \begin{cases} 1 & \text{if } \lambda_\ell \neq 0 \text{ and } \mu = (\lambda_1 - 1, \lambda_2 - 1, \dots, \lambda_\ell - 1), \\ x_i & \text{if } \lambda_\ell = 0 \text{ and there exists } j \in \{1, \dots, \ell\} \text{ such that} \\ & \mu = (\lambda_1 - 1, \dots, \lambda_{j-1} - 1, i, \lambda_j, \dots, \lambda_{\ell-1}), \\ 0 & \text{otherwise.} \end{cases} \quad (3.1)$$

The stationary distribution of the MJMC thus takes a particularly simple form, namely Theorem 2.3 amounts to:

**Theorem 3.2** The stationary distribution  $\pi$  of the MJMC is given by

$$\pi(\lambda) = \frac{1}{Z_{h,k}} \prod_{i=1}^{\ell} y_{\lambda_i} \quad (3.2)$$

where  $\lambda = (\lambda_1, \dots, \lambda_\ell)$  is an element of  $\text{Par}_{k,\ell}$  and where the  $y_m$  are as in (2.4).

In Ayyer et al., we provide a direct proof of this statement without recourse to the enriched chain.

**Example 3.3** By specialization, we obtain the following interesting measures over  $\text{Par}_{k,\ell}$

$$\pi(\lambda) = \begin{cases} \frac{1}{\binom{h+1}{k+1}} \prod_{i=1}^{\ell} (k+1 - \lambda_i) & \text{for } x_i = \frac{1}{k+1}, \\ \frac{1}{q^{k\ell} \binom{h+1}{k+1}_{1/q}} \prod_{i=1}^{\ell} q^{\lambda_i} [k+1 - \lambda_i]_q & \text{for } x_i = \frac{q^i}{[k+1]_q}, \\ \frac{1}{\binom{h}{k}_q} \prod_{i=1}^{\ell} q^{\lambda_i} & \text{for } x_i = (1-q)^{1-\delta_{i,k}} q^i \end{cases} \quad (3.3)$$

where the normalization factors follow from (3.1).

### 3.2 Unbounded heights

As suggested in the conclusion of Warrington (2005), a first natural extension is to allow Magnus to throw balls arbitrarily high, or, in the integer partition model, to allow parts to be arbitrarily large. This corresponds to taking the limit  $h \rightarrow \infty$  of the MJMC, keeping the number of balls  $\ell$  fixed. We keep the MJMC prescription of choosing the  $i$ -th available site with probability  $x_{i-1}$ . We now have an infinite sequence  $(x_i)_{i \geq 0}$  of nonnegative real numbers such that  $\sum_{i=0}^{\infty} x_i = 1$ . An immediate extension of Proposition 2.2 is that this *Unbounded Multivariate Juggling Markov Chain* (UMJMC) is irreducible and aperiodic whenever  $x_0$  and infinitely many  $x_i$ 's are nonzero.

Theorem 3.2 stills holds with few adaptations. Setting

$$y_m = \sum_{j=m}^{\infty} x_j, \quad (3.4)$$

we define a  $\sigma$ -finite measure  $w$  over the set of partitions with at most  $\ell$  parts of unrestricted size via

$$w(\lambda) = \prod_{i=1}^{\ell} y_{\lambda_i}. \quad (3.5)$$



By the same lines as in the “direct” proof of Theorem 3.2, we find that  $w$  is an invariant measure of the UMJMC. Furthermore, it can be shown that this invariant measure is finite if and only if

$$\sum_{i=0}^{\infty} ix_i < \infty \quad (3.6)$$

in which case its total mass is given by the well-defined expression  $Z^{(\ell)} = h_{\ell}(y_0, y_1, y_2, \dots)$ . By standard results on Markov chains, the UMJMC is positive recurrent if and only if (3.6) holds.

**Example 3.4** Fix  $q \in (0, 1)$  and pick  $x_i = (1 - q)q^i$ . We recover the “JEP with memoryless height distribution” of parameter  $q$  considered in Leskelä and Varpanen (2012).

### 3.3 Infinitely many balls

We now consider another limit which consists in having Magnus juggle with infinitely many balls ( $\ell \rightarrow \infty$ ). In the partition model, this corresponds to removing the limitation on the number of parts. The transition probabilities are still defined as in Proposition 3.1, except that the case  $\lambda_{\ell} \neq 0$  never occurs (since a partition always has a finite number of parts). This is the so-called *Infinite Multivariate Juggling Markov Chain* (IMJMC).

If  $x_0 > 0$ , then the IMJMC has a unique closed communicating class, whose all states are aperiodic. They are precisely the integer partitions whose parts are smaller than or equal to  $\sup\{i : x_i > 0\}$ . In particular, if infinitely many  $x_i$ ’s are nonzero, then the IMJMC is irreducible.

Again, we find that an invariant measure of the IMJMC is given by

$$w(\lambda) = \prod_{i=1}^{\infty} y_{\lambda_i} \quad (3.7)$$

with  $\lambda$  an arbitrary integer partition and  $y_m$  as in (3.4). Its total mass reads  $Z = \prod_{m=1}^{\infty} 1/(1 - y_m)$  and is finite (i.e. the IMJMC is positive recurrent) if and only if (3.6) holds.

**Example 3.5** Consider again the geometric case  $x_i = (1 - q)q^i$ ,  $q \in [0, 1)$ . Then, the stationary distribution is nothing but the “ $q^{\text{size}}$ ” measure over arbitrary integer partitions.

## 4 Extensions with a fluctuating number of balls

We now mention, again without proofs, our results regarding extensions of the MJMC where the number of balls is not fixed but is allowed to fluctuate. These extensions are the natural multivariate generalizations of the so-called *add-drop* and *annihilation* models introduced in (Warrington, 2005, Section 4), to which we refer for motivations. Both models are defined on the same state space and have the same transition graph. The basic state space of the model will be  $\text{St}_h = \{\circ, \bullet\}^h$ , with  $h$  a fixed nonnegative integer. It is here convenient to read a word from right to left, and for  $A \in \text{St}_h$  and  $i$  a nonnegative integer, we let  $S_i(A)$  be the word obtained by replacing the  $i$ -th occurrence of  $\circ$  in  $A$  by  $\bullet$ , upon reading the word *from the right* (if  $i$  is equal to 0 or larger than the number of occurrences of  $\circ$  in  $A$  then we set  $S_i(A) = A$  by convention). Note that  $S_i(A) = T_{k-i}(A)$  for  $A \in \text{St}_{h,k}$  and  $1 \leq i \leq k$ , with  $T$  as in Section 2.1. The state space of the enriched model will be the set  $\mathcal{S}(H)$  of all set partitions of  $\{1, \dots, H\}$ , with  $H = h + 1$ , and we recall the notations from Section 2.3:  $\psi$  is a surjection from  $\mathcal{S}(H)$  onto  $\text{St}_h$  and  $\sigma \mapsto \sigma^{\downarrow}$  is a mapping

from  $\mathcal{S}(H)$  to  $\mathcal{S}(h)$ . For  $\tau \in \mathcal{S}(h)$  and  $i$  a nonnegative integer, we let  $J_i(\tau) \in \mathcal{S}(H)$  be the set partition obtained by inserting  $H$  into the  $i$ -th block of  $\tau$ , now numbered by *decreasing* order of maxima (if  $i$  is equal to 0 or larger than the number of blocks of  $\tau$  then we set  $J_i(\tau) = \tau \cup \{H\}$  by convention). Note that  $J_i(\tau) = I_{K-i}(\tau)$  for  $\tau \in \mathcal{S}(h, K)$  and  $1 \leq i \leq K$ . Observe that we have the fundamental “intertwining” relation  $\psi(J_i(\tau)) = S_i(\psi(\tau) \circ)$ .

The basic transition graph is defined as follows: for any  $A = a_1 a_2 \dots a_h \in \text{St}_h$  and  $i \geq 0$ , we have an oriented edge from  $A$  to  $S_i(a_2 \dots a_h \circ)$ . See figure 3 for  $h = 2$ . Similarly, the enriched transition graph is obtained by connecting each  $\sigma \in \mathcal{S}(H)$  to  $J_i(\sigma^\downarrow)$  for all  $i \geq 0$ . It is not difficult to check that both transition graphs are strongly connected.

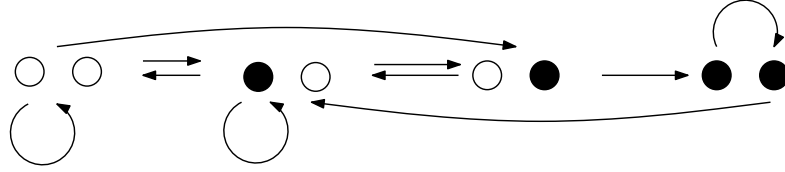

Fig. 3: The basic transition graph for  $h = 2$

#### 4.1 Add-drop juggling

**Definition 4.1** Given  $h$  a nonnegative integer and  $z_0, z_1, \dots, z_h$  nonnegative real numbers, the (multivariate) add-drop model is the Markov chain on the state space  $\text{St}_h$  for which the transition probability from  $A = a_1 a_2 \dots a_h$  to  $B$  reads

$$P_{A,B} = \begin{cases} \frac{z_i}{z_0 + \dots + z_k} & \text{if } B = S_i(a_2 \dots a_h \circ) \text{ for some } i \in \{0, \dots, k\}, \\ 0 & \text{otherwise,} \end{cases} \quad (4.1)$$

with  $k$  the number of occurrences of  $\circ$  in  $a_2 \dots a_h \circ$ . The (multivariate) enriched add-drop model is the Markov chain on the state space  $\mathcal{S}(H)$  for which the transition probability from  $\sigma$  to  $\tau$  is given by

$$\tilde{P}_{\sigma,\tau} = \begin{cases} \frac{z_i}{z_0 + \dots + z_k} & \text{if } \tau = J_i(\sigma^\downarrow) \text{ for some } i \in \{0, \dots, k\}, \\ 0 & \text{otherwise,} \end{cases} \quad (4.2)$$

with  $k$  the number of blocks of  $\sigma^\downarrow$ .

Warrington’s add-drop model is recovered by taking  $z_0 = \dots = z_h = 1$ . It is easily seen that, in general, the chain is aperiodic with a unique communicating class whenever  $z_0 > 0$ . Here is the multivariate generalization of (Warrington, 2005, Theorem 3, item 1):

**Theorem 4.2** The stationary distribution of the add-drop model is given by

$$\Pi(B) = \frac{z_0^k}{Z_h} \prod_{\substack{i=1 \\ b_i=\bullet}}^h (z_1 + \dots + z_{\psi_i(B)+1}), \quad (4.3)$$

for  $B = b_1 \dots b_h \in \text{St}_{h,k}$ , with  $\psi_i(B) = \#\{j : i < j \leq h, b_j = \circ\}$  and

$$Z_h = \sum_{k=0}^h z_0^k h_{h-k}(z_1, z_1 + z_2, \dots, z_1 + z_2 + \dots + z_{k+1}), \quad (4.4)$$

where  $h_\ell$  denotes again the complete homogeneous symmetric polynomial of degree  $\ell$ .

It can be shown that the add-drop model is indeed the projection of the enriched chain, and furthermore that the enriched chain is aperiodic with a unique communicating class for  $z_0 > 0$ . Following the same line of arguments as in Section 2.3, proving Theorem 4.2 boils down to checking the simpler:

**Lemma 4.3** For  $\sigma \in \mathcal{S}(H)$  with, say,  $K$  blocks and  $C_\sigma(s, t)$  is in Definition 2.8, the monomial

$$\tilde{W}(\sigma) = z_0^{K-1} \prod_{(s,t) \text{ arch of } \sigma} z_{C_\sigma(s,t)}, \quad (4.5)$$

defines an unnormalized stationary distribution of the enriched chain.

## 4.2 Annihilation juggling

**Definition 4.4** Given  $h$  a nonnegative integer and  $z_1, \dots, z_h, z_{h+1}$  nonnegative real numbers such that  $z_1 + \dots + z_{h+1} = 1$ , the (multivariate) annihilation model is the Markov chain on the state space  $\text{St}_h$  for which the transition probability from  $A = a_1 a_2 \dots a_h$  to  $B$  reads

$$P_{A,B} = \begin{cases} z_i & \text{if } B = S_i(a_2 \dots a_h \circ) \text{ for some } i \in \{1, \dots, k\}, \\ z_{k+1} + \dots + z_{h+1} & \text{if } B = a_2 \dots a_h \circ, \\ 0 & \text{otherwise,} \end{cases} \quad (4.6)$$

with  $k$  the number of occurrences of  $\circ$  in  $a_2 \dots a_h \circ$ . Similarly, the (multivariate) enriched annihilation model is the Markov chain on the state space  $\mathcal{S}(H)$  (recall that  $H = h + 1$ ) for which the transition probability from  $\sigma$  to  $\tau$  is given by

$$\tilde{P}_{\sigma,\tau} = \begin{cases} z_i & \text{if } \tau = J_i(\sigma^\downarrow) \text{ for some } i \in \{1, \dots, k\}, \\ z_{k+1} + \dots + z_H & \text{if } \tau = \sigma^\downarrow \cup \{H\}, \\ 0 & \text{otherwise,} \end{cases} \quad (4.7)$$

with  $k$  the number of blocks of  $\sigma^\downarrow$ .

**Remark 4.5** By our convention for defining  $S_i(A)$  (resp.  $J_i(\tau)$ ) when  $i$  is larger than the number of occurrences of  $\circ$  in  $A$  (resp. the number of blocks of  $\tau$ ), we have the more compact expression  $P_{A,B} = \sum z_i$  (resp.  $\tilde{P}_{\sigma,\tau} = \sum z_i$ ) where the sum runs over all  $i \in \{1, \dots, h + 1\}$  such that  $B = S_i(a_2 \dots a_h \circ)$  (resp.  $\tau = J_i(\sigma^\downarrow)$ ).

Warrington's annihilation model is recovered by taking  $z_1 = \dots = z_{h+1} = 1/(h + 1)$ . Here is the multivariate generalization of (Warrington, 2005, Theorem 3, item 2):

**Theorem 4.6** *The stationary distribution of the annihilation model is given by*

$$\Pi(B) = \prod_{\substack{i=1 \\ b_i=\bullet}}^h (z_1 + \cdots + z_{\psi_i(B)+1}) \prod_{j=1}^k (z_{j+1} + \cdots + z_{h+1}), \quad (4.8)$$

for  $B = b_1 \dots b_h \in St_{h,k}$ , with  $\psi_i(B) = \#\{j : i < j \leq h, b_j = \circ\}$  as before. Similarly, the stationary distribution of the enriched annihilation model is given by

$$\tilde{\Pi}(\sigma) = \prod_{(s,t) \text{ arch of } \sigma} z_{C_\sigma(s,t)} \prod_{i=1}^{K-1} (z_{i+1} + \cdots + z_H), \quad (4.9)$$

with  $\sigma \in \mathcal{S}(H)$  and  $K$  its number of blocks. There is no normalization factor, as  $\Pi$  and  $\tilde{\Pi}$  are already normalized for  $z_1 + \cdots + z_{h+1} = 1$ .

The annihilation has a remarkable property that departs it from the generic MJMC and add-drop model.

**Theorem 4.7** *For any initial probability distribution  $\eta$  over  $St_{h,k}$  or  $\tilde{\eta}$  over  $\mathcal{S}(H)$ , the distribution at time  $h$  is equal to the stationary distribution, namely*

$$\eta P^h = \Pi, \quad \tilde{\eta} \tilde{P}^h = \tilde{\Pi}. \quad (4.10)$$

*In particular, the only eigenvalues of  $P$  and  $\tilde{P}$  are 1 (with multiplicity 1) and 0.*

This result is stronger than a statement about mixing times since we reach the exact stationary state in finite time! See Ayyer et al. for a proof.

## 5 Conclusion and discussion

For the infinite setting, we prove that the UMJMC (for fixed  $\ell$ ) is positive recurrent if and only if  $\sum_i i x_i < \infty$ . When this condition does not hold, the chain may either be null recurrent or transient. For  $\ell = 1$ , the chain is null recurrent. Figuring out the situation for  $\ell > 1$  is an intriguing open question.

Now that we gave some nice combinatorial interpretations of the stationary distribution of the MJMC, we would like to know if some special values of the  $x_i$ 's could give some nice behaviors in a suitable limit, for example display some phase transitions or shock formations. Such phenomena were observed for instance in a related ‘‘juggling model with exclusion dynamics’’ introduced in Arita et al. (2013).

## Acknowledgements

The authors want to thank N. Curien, P. Di Francesco, B. Haas, M. Josuat-Vergès and I. Kortchemski for fruitful discussions during the completion of this work.

## References

C. Arita, J. Bouttier, P. L. Krapivsky, and K. Mallick. Asymmetric exclusion process with global hopping. *Phys. Rev. E*, 88:042120, Oct 2013.

- A. Ayer, J. Bouttier, S. Corteel, and F. Nunzi. Multivariate juggling probabilities. arXiv:1402.3752.
- J. Buhler, D. Eisenbud, R. Graham, and C. Wright. Juggling drops and descents. *The American Mathematical Monthly*, 101(6):pp. 507–519, 1994.
- S. Butler and R. Graham. Enumerating (multiplex) juggling sequences. *Annals of Combinatorics*, 13(4): 413–424, 2010. doi: 10.1007/s00026-009-0040-y.
- F. Chung and R. Graham. Universal juggling cycles. In *Combinatorial number theory*, pages 121–130. de Gruyter, Berlin, 2007.
- F. Chung and R. Graham. Primitive juggling sequences. *Amer. Math. Monthly*, 115(3):185–194, 2008.
- S. L. Devadoss and J. Mugno. Juggling braids and links. *Math. Intelligencer*, 29(3):15–22, 2007.
- R. Ehrenborg and M. Readdy. Juggling and applications to q-analogues. *Discrete Mathematics*, 157(1 - 3):107 – 125, 1996.
- A. Engström, L. Leskelä, and H. Varpanen. Geometric juggling with q-analogues. arXiv:1310.2725.
- H. W. Gould. The  $q$ -Stirling numbers of first and second kinds. *Duke Math. J.*, 28:281–289, 1961.
- A. Knutson, T. Lam, and D. E. Speyer. Positroid varieties: juggling and geometry. *Compos. Math.*, 149(10):1710–1752, 2013.
- L. Leskelä and H. Varpanen. Juggler’s exclusion process. *J. Appl. Probab.*, 49(1):266–279, 2012. arXiv:1104.3397.
- D. A. Levin, Y. Peres, and E. L. Wilmer. *Markov chains and mixing times*. American Mathematical Society, Providence, RI, 2009. With a chapter by James G. Propp and David B. Wilson.
- B. Polster. *The mathematics of juggling*. Springer-Verlag, New York, 2003.
- J. D. Stadler. *Schur functions, juggling, and statistics on shuffled permutations*. ProQuest LLC, Ann Arbor, MI, 1997. ISBN 978-0591-51450-6. Thesis (Ph.D.)—The Ohio State University.
- J. D. Stadler. Juggling and vector compositions. *Discrete Math.*, 258(1-3):179–191, 2002.
- G. S. Warrington. Juggling probabilities. *The American Mathematical Monthly*, 112(2):pp. 105–118, 2005.