



HAL
open science

A new multi-objective mathematical model for dynamic cell formation under demand and cost uncertainty considering social criteria

Farzad Niakan, Armand Baboli, Thierry Moyaux, Valérie Botta-Genoulaz

► To cite this version:

Farzad Niakan, Armand Baboli, Thierry Moyaux, Valérie Botta-Genoulaz. A new multi-objective mathematical model for dynamic cell formation under demand and cost uncertainty considering social criteria. *Applied Mathematical Modelling*, 2016, 40 (4), pp.2674-2691. 10.1016/j.apm.2015.09.047 . hal-01575867

HAL Id: hal-01575867

<https://hal.science/hal-01575867v1>

Submitted on 4 Feb 2020

HAL is a multi-disciplinary open access archive for the deposit and dissemination of scientific research documents, whether they are published or not. The documents may come from teaching and research institutions in France or abroad, or from public or private research centers.

L'archive ouverte pluridisciplinaire **HAL**, est destinée au dépôt et à la diffusion de documents scientifiques de niveau recherche, publiés ou non, émanant des établissements d'enseignement et de recherche français ou étrangers, des laboratoires publics ou privés.

A new multi-objective mathematical model for dynamic cell formation under demand and cost uncertainty considering social criteria

Farzad NIAKAN^a, Armand BABOLI^{a1}, Thierry MOYAUX^a,
Valérie BOTTA-GENOULAZ^a

^a *INSA-Lyon, DISP Laboratory, F-69621, Villeurbanne, France*

Abstract

This paper examines a new multi-objective mathematical model in a Dynamic Cell Formation Problem (DCFP), where social criteria and uncertainty conditions are considered. Although corporate social responsibility is one of the important issues that are increasingly considered by researchers and practitioners, it is largely overlooked in the literature on DCFP. In this paper the first objective function minimizes costs related to a machine (machine fixed and variable costs, machine procurement and relocation costs, intra-cell and inter-cell movement costs) and wages, while social issues are maximized (e.g. potential machine hazards are minimized, while job opportunities are maximized). A robust counterpart of the proposed model is then developed by applying the recent robust optimization theory. Afterwards, due to the NP-hardness of DCFP, a non-dominated sorting genetic algorithm (NSGA-II) as a meta-heuristic method is designed. Finally, two deterministic and robust mathematical formulations are compared by a number of nominal realizations under randomly generated test problems. This serves to assess the robustness of the solution achieved by the proposed robust optimization model. The result obtained demonstrates the ability of the robust model to reach appropriate solutions at all levels of uncertainty, specifically when a feasible solution cannot be found with the deterministic model.

Keywords: dynamic cell formation; robust optimization; corporate social responsibility; multi-objective optimization; non-dominated sorting genetic algorithm

1 Introduction

To remain competitive, manufacturers and producers have been forced to increase the productivity and flexibility of manufacturing systems. The Cellular Manufacturing System (CMS), one of the well-known production systems, is applied to this end. CMS based on Group Technology (GT) attempts to classify parts and machines in order to create cells and part families. This is called a Cell Formation Problem (CFP). This classification is based on the similarities in the geometry and process requirements of each part, so as to take advantage of the main benefits such as reduction of Work-In-Process (WIP), flow time and space utilization, while also improving production planning and control. But from another point of view, most of the existing cell formation methods have been developed just for one period of the planning horizon, and some parameters like the decrease of product life cycles and product mix changes under dynamic condition require cells of the cellular manufacturing system to be reconfigured (Fig. 1). This is necessary to maintain a high level of performance. Therefore, optimal cells formed in one period might not be optimal in another period, because this reconfiguration of part families and machine grouping may include either substitution of machines between cells or a change in the number

¹ * Corresponding author. Tel: +33472436201, Fax: +33472438538
E-mail address: armand.baboli@insa-lyon.fr (Armand Baboli).

of cells. These reasons provide sufficient motivation to pursue the research in multi-period or Dynamic Cellular Manufacturing System (DCMS) approaches.

{Please insert Fig. 1 here. }

At the same time, pressure from NGOs, social communities and the media is currently prompting researchers and firms to take Corporate Social Responsibility (CSR) into account. For example, some well-known corporations such as Shell, Nike and Wal-Mart have suffered extensive damage due to media reports and public awareness of their CSR activities [1],[2]. CSR concerns the effect of corporate activities on different social entities such as environment preservation, human rights, occupational safety, etc. [3]. As CSR attempts to incorporate social factors into economic models to provide more benefits for society as a whole, it has an important role in the sustainable improvement of countries. Despite the importance of CSR, one of the neglected issues involved in CMS is CSR, to the extent that there has been no relevant work on the subject.

The research presented in this paper contributes to the existent literature in two ways. First, a multi-objective mathematical model is formulated to integrate the relative costs of DCFP and social issues. In other words, we try to make a trade-off between economic and social criteria while designing CMS in each period. Job opportunities and potential machine hazards are social issues that we have extracted according to the social accountability standards (SAI 8000 [4], ISO 26000 [5]) and ergonomic guideline (GRI [6], NIOSH [7]), and applied as a second objective. The robust counterpart of the presented model is then also developed to cope with the uncertainty in demand, machine availability and relevant costs of machines. In order to handle uncertainty in parameters and obtain robust optimal solutions, several numerical examples are solved by the NSGA-II algorithm presented here.

The remainder of this paper is organized as follows. In Section 2, we review the relevant literature and define the research motivation. The mathematical model and main assumptions are then presented in Section 3. Section 4 elaborates the robust counterpart mathematical model, while the proposed NSGA-II algorithm is described in Section 5. Computational results and numerical analysis are presented in Section 6. Finally, Section 8 ends with conclusions and some future research directions.

2 Literature review

First, we present a brief review of the related literature on dynamic cellular manufacturing systems (DCMS). Due to the large number of researches in this area, we have concentrated only on recent studies. In order to make the research gap clear, we have investigated previous studies with regard to several aspects such as objectives, problem-solving approaches, parts movement (inter/intra cell), and the nature of applied parameters (deterministic, stochastic, etc.).

Rheault et al. [8] were the first to introduce the concept of dynamic environment in the cell formation problem. Schaller et al. [9] integrated the cell formation problem with inventory aspects. They proved their presentation model by a multiple heuristics procedure and evaluated several alternative lower bounding methods. Chen and Cao [10] proposed a mathematical model for a multi-period cellular manufacturing system (CMS) to minimize the total cost, including: inter-cell material handling, inventory costs, and setting up of manufacturing cells. These authors also developed a Tabu Search method to obtain a sound solution and show the efficiency of their model.

Tavakkoli-Moghaddam et al. [11] presented a nonlinear integer model in DCMS with consideration of machine capacity limitation, machine replication, and inter-cell movements that perform in batches.

They used constant and variable costs as well as reconfiguration and inter-cell movement costs to formulate their objective function. These authors solved their models by several traditional meta-heuristics comprising Genetic Algorithm (GA), Tabu Search (TS) and Simulated Annealing (SA), and then compared solutions obtained by means of each method to define the best algorithm. Tavakkoli-Moghaddam et al. [12] applied a new Memetic Algorithm (MA) to solve their DCMS model. Defersha and Chen [13] formulated a new comprehensive model containing dynamic cell configuration, alternative routings, lot splitting, sequence of operations and workload balancing. They also considered machine adjacency and cell-size capacity as constraints in their proposed model. Safaei et al. [14],[15] presented a DCMS mathematical model with uncertain circumstances, assuming fuzzy demand and fuzzy machine availability. They solved their mixed-integer programming model by developing fuzzy programming to determine optimal cell configuration with maximum satisfaction of the fuzzy objective and constraint. Safaei et al. [16] proposed a mixed-integer programming model in DCMS with consideration batch inter/intra-cell material handling, sequence of operations, alternative process plans and machine replication. In this study, the authors minimized machine variable/constant costs, inter/intra-cell movements and reconfiguration costs as an objective function. They used a hybrid meta-heuristic called MFA-SA (Mean Field Annealing-Simulated Annealing) to solve the proposed model and showed the efficiency of their solving method by comparing it with classical SA.

Defersha and Chen [17] integrated DCMS with production lot sizing and formulated a mathematical model to minimize both production and quality-related costs, such as operation costs, setup costs and inventory costs. They solved by a linear programming embedded GA. Aryanezhad et al. [18] proposed a model to transact with a Simultaneous Dynamic Cell Formation and Worker assignment Problem (SDCWP). The objective function of their model has two components: production costs, such as inter-cell material handling costs and machine costs in the planning horizon; and human issues consisting of hiring costs, firing costs, training costs and salaries. Safaei and Tavakkoli-Moghaddam [19] developed a mathematical model to integrate multi-period cell formation and subcontracted production planning in DCMS. In this study the authors made a trade-off between production and outsourcing costs in the reconfiguration of system. Bajestani et al. [20] formulated a multi-objective mathematical model in DCMS and minimized the sum of various costs and the total cell load variation simultaneously. They obtained a locally Pareto-optimal frontier by using a new Multi-Objective Scatter Search (MOSS) method. Wang et al. [21] presented a non-linear mixed integer program to model a DCSM with three conflicting objectives (machine relocation cost, the utilization rate of machine capacity, and the total number of inter-cell moves over the entire planning horizon). Deljoo et al. [22] improved previous models presented in the literature by correcting some essential errors which weakened the efficiency of the model.

Mahdavi et al. [23] proposed an integer non-linear programming in DCMS with consideration of labor aspects such as worker assignment, alternative workers, available time of workers, hiring and firing costs and wages. They utilized holding and backordering costs in their model as an inventory aspect to make it more realistic. Javadian et al. [24] presented a multi-objective problem of cellular manufacturing systems in dynamic and deterministic production environments to minimize total cell load variation and the sum of the miscellaneous costs (machine costs, inter/intra-cellular material handling, back orders, inventory holding and subcontracting) simultaneously. A Non-Dominated Sorting Genetic Algorithm (NSGA-II) method was developed to obtain optimal Pareto-frontier. Rafiee et al. [25] integrated DCMS and inventory lot sizing problems by formulating a comprehensive mathematical model. The proposed model was considered with several design factors, such as machine procurement, cell reconfiguration, preventive and corrective maintenance, intra/inter-cell material handling, subcontracting, inventory cost, and defective parts replacement costs. Saxena and Jain [26] developed a mixed-integer nonlinear programming model to merge machine breakdown effects and

DCMS by incorporating reliability modeling. The proposed model seeks to minimize the following: intra/inter-cell movement costs and machine procurement costs; machine variable/constant costs, production costs, part holding costs, subcontracting and reconfiguration costs, and machine breakdown repair costs such as production time loss cost due to machine breakdown. Kia et al. [27] proposed a new mixed-integer non-linear programming model for DCMS by integrating three major decisions in the design of a CMS (cell formation, group layout and group scheduling) and developed an efficient SA method to solve their model. The objective function of this model is minimizing total costs of intra/inter-cell movement, machine relocation, machine procurement, machine overhead and machine processing.

Rafiei and Ghodsi [28] presented a bi-objective CMS problem, in which they considered human-related issues. The proposed model sought to minimize various costs, including machine procurement, relocation costs, machine variable costs, inter/intra-cell movement costs, overtime costs, and labor shifting costs, as a first objective function, and to maximize labor utilization, as a second objective function. They furthermore suggested a hybridization of the ant colony optimization (ACO) algorithm with GA to solve their models. Majazi-Dalfard [29] developed a new nonlinear integer programming model, into which he incorporated effects of distance in material flow as an important factor of decision making. In this study he applied a new simulated annealing embedded in branch-and-cut to solve the proposed problem. Javadi et al. [30] developed a mathematical model to minimize the total costs of rearrangement and inter/intra-cell movements. They also proposed a hybrid of an electro-magnetism-like (EM-like) algorithm and GA as a solution approach. Aghajani et al. [31] presented a multi-objective model for dynamic cell formation where the demand is probabilistic. The proposed model consisted of three conflict objectives; reconfiguration cost, penalty cost of machine underutilization, and system failure rate. The authors also solved the model by developing a NSGA-II algorithm and comparing the result with the ϵ -constraint method to show its efficiency. Bootaki et al. [32] presented a bi-objective model in robust design of DCMS, with a fuzzy, random demand. The objective function of models is the minimization of inter-cell movements while the machine and worker utilization are maximized. A new goal programming method named 'Percentage Multi-Choice Goal Programming' (PMCGP) is also proposed to verify the model. Paydar and Saidi-Mehrabad [33] formulated a bi-objective model to integrate cell formation and supply chain (procurement, production and distribution planning) which decreases distribution and procurement costs and increases the customer response rate. They applied revised multi-choice goal programming to solve the case study example and to find a compromise solution. Renna and Ambrico [34] developed a model for reconfiguration and scheduling in DCMS. They assumed demands to be probabilistic in discrete probability scenarios. The authors also applied a simulation environment to test the proposed method compared to the manufacturing system without reconfiguration. Table 1 shows the classification of previous study about DCMS.

{Please insert Table 1 here.}

Most of the criteria studied in these papers are economic rather than social. There are no studies that focus specifically on social criteria, although some research in supply chain configuration does take social issues into account. Carter and Jennings [3] were the first to incorporate the concept of the CSR into the supply chain. Cruz and Wakolbinger [1] and Cruz and Liu [39] studied the role of social responsibility on the supply chain and some of its components such as suppliers, retailers and customers.

The difficulty with measuring social responsibility is generally due to its complexity and scope. It can thus be said that it is in a sense inconceivable to measure all aspects of social responsibility. However, for preparation and allocating corporate social responsibility (CSR) in companies, several standards and guidelines have been developed, such as ISO 26000 [5], SAI 8000 [4], GRI [6] and NIOSH [7]. Based on these documents, we have identified two social criteria that are very important in DCMS.

2.1 Motivation

As noted in the previous section, based on the above literature review we have found no research that considers social responsibility issues in the design of DCMS. This aspect was moreover generally neglected in previous research as well. The first contribution of the research presented here is to develop a new multi-objective mathematical model for DCMS configuration with social aspects. In other words, we try to make a trade-off between economic and social criteria while designing CMS in each period. Due to high levels of interaction between human and manufacturing environments, social issues are particularly important. Among of these issues, stress due to job loss [40] and occupational injuries [41] caused by ergonomic problems are the most common. In our mathematical model we therefore consider job opportunities and potential machine hazards as social objective functions.

The second contribution of this work is that it develops a robust counterpart of the proposed model to deal with the uncertainty of demand, machine availability and machine costs. It may seem easier to use the deterministic parameter in a DCMS configuration, but in the real world many parameters must be considered as uncertain. Moreover, a feasible solution cannot be found for the deterministic approach. These considerations may slightly affect the economic performance of a system, but they allow us to approach reality and above all to have a feasible solution under different kinds and levels of uncertainty.

Due to the complexity of the model (NP Hard) and in order to deal with the uncertainty of parameters and to obtain robust optimal solutions, one of the most common meta-heuristic methods, the NSGA-II algorithm, has been selected. The biggest challenge is to design this meta-heuristic method for DCMS problems. Finally, several numeric experiments allow us to validate the performance of a robust counterpart of the proposed model by sensitivity analysis of uncertainty levels.

3 Problem description and formulation

In this section the new multi-objective mathematical model is proposed to trade-off between two important objectives in DCMS problems. The first objective function of the model is to minimize some of the costs, including machine fixed and variable costs, inter-cell movement costs, intra-cell movement costs, machine procurement costs, machine relocation costs and workers' wages. The second objective function is to optimize the social issues of the problem by maximizing job opportunities and minimizing potential machine hazards for labor during the planning phase.

In this study an attempt has been made to choose social measures in such a way that they are closely related to the DCMS decisions, have an important role in the DCMS problem, and can be computed and formulated simply in the mathematical model. To this end, two social issues are considered in the model: (1) the number of job opportunities created and (2) the number of potential hazards of machines. The first measure represents the variation of job opportunities created due to the hiring and firing of labor [4],[5] resulting from the buying and selling of machines. The second measure, which reflects the average fraction of potential hazards of each machine [6],[7] shows how much injury, illness and damage each machine causes workers. The latter measure is taken into account through a parameter called "average fraction of potential machine hazard". This average fraction is a continuous number between 0 (the most safe) and 1 (the most dangerous) and is defined by the Decision Maker (DM) using a safety checklist, talking to workers, reviewing the manufacturer's information, and checking the injury and incident reports of each machine. Because of differences in the units of two considered social measures, we have aggregated social measures to the one objective function by normalized weighting method. This aggregation with weighting factors not only represents the importance of each measure

but also decreases the computational complexity of evaluating each solution with social aspects [42],[43]. Other assumptions used for formulating the mathematical model are presented as follows:

3.1 Problem assumptions

1. Each part has an operation sequence and must be processed according to the sequence which is extracted from the route sheet parts.
2. The demand of each part type in each period is an uncertain parameter.
3. The capability of each machine for processing parts is known. The time capacity of each machine is also an uncertain parameter.
4. The fixed cost of each machine is independent of the assigned workload. This cost is considered for each machine whether or not it is used in the planning horizon, and includes the costs of total maintenance and overhead services. This cost is considered as an uncertain parameter.
5. The variable cost of each machine includes the operation cost and depends on the workload assigned to each machine. This parameter of the problem is also uncertain.
6. The machine purchasing and selling costs in each period are considered as an uncertain value and include machine prices and freight charges, which means that removal costs between the place of storage and that of installation are not considered.
7. The relocation cost (installation, un-installation, shifting) of each machine type between two periods is an uncertain parameter.
8. Each machine type can process several operations, in other words, each processing of parts can be performed on different machine types with various processing times.
9. The upper and lower bound of the cell size is known and is fixed in all periods.
10. The inter-intra movements of parts are performed in batches with different sizes and the related cost of this movement is dependent on the distance traveled. For decreasing the complexity of the problem we assumed that the distance between two cells (inter) is the same, and that for each cell, the distance between two machines (intra) is the same. Furthermore, the dimensions of all machine types are equal.
11. The labor leveling rule (hiring – firing) in each period allows the DM to change the labor level to at most a certain percentage (λ_h) of the labor level in the previous period.

3.2 Notations

Indices

p	index for part types ($p = 1, \dots, P$)
c	index for manufacturing cells ($c = 1, \dots, C$)
m	index for machine types ($m = 1, \dots, M$)
j	index for operation of parts p ($j = 1, \dots, O_p$)
h	index for number of periods ($h = 1, \dots, H$)

Parameters

P	number of parts
H	number of periods
O_p	number of operations for part type p
C	maximum number of cells
M	number of machine types
D_{ph}	demand for part p in period h
B_p^{inter}	batch size for inter-cell movement of part p
B_p^{intra}	batch size for intra-cell movement of part p
γ_p^{inter}	inter-cell movement cost per batch
γ_p^{intra}	intra-cell movement cost per batch. It is assumed that $\forall p (\gamma_p^{intra} / B_p^{intra}) < (\gamma_p^{inter} / B_p^{inter})$
α_{mh}	fixed cost of machine type m in period h
β_{mh}	variable cost of machine type m in period h per unit of time
δ_{mh}	relocation cost of machine type m in period h
T_{mh}	time-capacity of machine type m in period h
UB	maximum cell size
LB	minimum cell size
L_m	amount of labor that is required for machine type m
φ_{mh}	Purchase cost of machine type m in period h
ω_{mh}	marginal revenue from selling machine type m in period h
S_m	average fraction of potential hazard of machine type m
θ_{hd}	normalized weighting factor of total number of potential hazard of machine type m
θ_{jo}	normalized weighting factor of total number of job opportunities created
λ_h	maximum percentage of labor leveling variation in period h
sa_{mh}^L	salary of labor machine type m in period h
t_{jpm}	time required to process operation j of part p on machine type m
a_{jpm}	1, if operation j of part p can be done on machine type m ; 0 otherwise

Variables

N_{mch}	number of machine type m assigned to cell c at the beginning of period h
K_{mch}^+	number of machine type m added to cell c at the beginning of period h
K_{mch}^-	number of machine type m removed to cell c at the beginning of period h
I_{mh}^+	number of machine type m purchased at the beginning of period h
I_{mh}^-	number of machine type m sold at the beginning of period h
hi_h	number of labor hired in period h
fi_h	number of labor fired in period h
x_{jpmch}	1, if operation j of part p is performed in cell c in period h by machine type m ; 0 otherwise

3.3 Mathematical formulation

$$\begin{aligned}
\text{Min } Z_1 = & \sum_{h=1}^H \sum_{m=1}^M \sum_{c=1}^C \alpha_{mh} N_{mch} + \sum_{h=1}^H \sum_{m=1}^M \sum_{c=1}^C \sum_{p=1}^P \sum_{j=1}^{O_p} \beta_{mh} D_{ph} t_{jpm} x_{jpmch} \\
& + \frac{1}{2} \sum_{h=1}^H \sum_{p=1}^P \gamma_p^{\text{inter}} \left[\frac{D_{ph}}{B_p^{\text{inter}}} \left| \sum_{j=1}^{O_p-1} \sum_{c=1}^C \left| \sum_{m=1}^M x_{(j+1)pmch} - \sum_{m=1}^M x_{jpmch} \right| \right. \right. \\
& + \left. \left. \frac{1}{2} \sum_{h=1}^H \sum_{p=1}^P \gamma_p^{\text{intra}} \left[\frac{D_{ph}}{B_p^{\text{intra}}} \left| \sum_{j=1}^{O_p-1} \sum_{c=1}^C \left(\sum_{m=1}^M \left| x_{(j+1)pmch} - x_{jpmch} \right| - \left| \sum_{m=1}^M x_{(j+1)pmch} - \sum_{m=1}^M x_{jpmch} \right| \right) \right] \right] \right) \quad (1) \\
& + \sum_{h=1}^H \sum_{m=1}^M \sum_{c=1}^C N_{mch} L_m S a_{mh}^L + \frac{1}{2} \sum_{h=1}^H \sum_{m=1}^M \sum_{c=1}^C \delta_{mh} (K_{mch}^+ + K_{mch}^-) \\
& + \sum_{h=1}^H \sum_{m=1}^M I_{mh}^+ \varphi_{mh} - \sum_{h=1}^H \sum_{m=1}^M I_{mh}^- \omega_{mh}
\end{aligned}$$

$$\text{Max } Z_2 = \theta_{jo} \left(\sum_{h=1}^H h i_h - \sum_{h=1}^H f i_h \right) - \theta_{hd} \left(\sum_{h=1}^H \sum_{m=1}^M \sum_{c=1}^C N_{mch} S_m \right) \quad (2)$$

S.t.

$$\sum_{c=1}^C \sum_{m=1}^M a_{jpm} x_{jpmch} = 1 \quad \forall j, p, h \quad (3)$$

$$x_{jpmch} \leq a_{jpm} \quad \forall j, p, c, m, h \quad (4)$$

$$\sum_{p=1}^P \sum_{j=1}^{O_p} D_{ph} t_{jpm} x_{jpmch} \leq T_{mh} N_{mch} \quad \forall m, c, h \quad (5)$$

$$N_{mc(h-1)} + K_{mch}^+ - K_{mch}^- = N_{mch} \quad \forall m, c, h \quad (6)$$

$$\sum_{c=1}^C N_{mc(h-1)} + I_{mh}^+ - I_{mh}^- = \sum_{c=1}^C N_{mch} \quad \forall m, h \quad (7)$$

$$\sum_{m=1}^M N_{mch} \leq UB \quad \forall c, h \quad (8)$$

$$\sum_{m=1}^M N_{mch} \geq LB \quad \forall c, h \quad (9)$$

$$\sum_{m=1}^M I_{mh}^+ L_m \leq h i_h \quad \forall h \quad (10)$$

$$\sum_{m=1}^M I_{mh}^- L_m \leq f i_h \quad \forall h \quad (11)$$

$$\left| \sum_{m=1}^M \left[(I_{mh}^+ - I_{mh}^-) L_m \right] \right| \leq \left(\sum_{m=1}^M \left(\sum_{c=1}^C N_{mc(h-1)} \right) L_m \right) \lambda_h \quad \forall h \quad (12)$$

$$x_{jpmch} \in \{0,1\}, N_{mch}, K_{mch}^+, K_{mch}^-, I_{mh}^+, I_{mh}^-, h i_h, f i_h \geq 0 \text{ and integer} \quad (13)$$

Objective function (1) represents the minimizing of total costs, that includes eight terms: the first term relates to the machine fixed costs; the second term represents variable machine costs; the third term relates to the part's inter-cell movement costs; the fourth term represents the part's intra-cell movement costs; the fifth term includes wages or salaries; the sixth term represents machine relocation costs; the seventh term includes machine procurement costs; and the eighth term relates to revenue from

selling the machine. Objective function (2) maximizes the social issues of DCMS during the planning horizon that includes maximizing job opportunities and minimizing potential machines hazards. Constraint (3) ensures that each operation of a part is assigned to just one machine and one cell. Constraint (4) guarantees that the process of each part is assigned to the appropriate machines. Constraint (5) ensures that the time capacity of each machine is not exceeded. Constraints (6) and (7) ensure that in each planning period the number of machines is balanced. Constraints (8) and (9) determine the maximum and minimum cell sizes according to the defined upper and lower bound. Constraints (10) and (11) calculate the number of workers that are respectively hired and fired. Constraint (12) guarantees maximum labor leveling variation in each period. Constraint (13) defines non-negativity, binary and integer necessities of decision variables.

3.4 Linearization

The third and fourth terms of equation (1) in the proposed model make it a nonlinear equation. In order to transform it to a linear equation for the third term, two non-negative variables, Z_{jpch}^1 and Z_{jpch}^2 are added and then the third term is rewritten as follow:

$$\frac{1}{2} \sum_{h=1}^H \sum_{p=1}^P \gamma^{inter} \left[\frac{D_{ph}}{B_p^{inter}} \right] \sum_{j=1}^{O_p-1} \sum_{c=1}^C (z_{jpch}^1 + z_{jpch}^2) \quad (14)$$

Then following constraint must be added to the proposed model.

$$z_{jpch}^1 - z_{jpch}^2 = \sum_{m=1}^M x_{(j+1)pmch} - \sum_{m=1}^M x_{jpmch} \quad \forall j, p, c, h \quad (15)$$

Similarity, to linearize the fourth term of equation (1), y_{jpmch}^1 and y_{jpmch}^2 are introduced as two non-negative variables, the fourth term of the objective function is therefore rewritable

$$\frac{1}{2} \sum_{h=1}^H \sum_{p=1}^P \gamma^{intra} \left[\frac{D_{ph}}{B_p^{intra}} \right] \sum_{j=1}^{O_p-1} \sum_{c=1}^C \left(\sum_{m=1}^M (y_{jpmch}^1 + y_{jpmch}^2) - (z_{jpch}^1 + z_{jpch}^2) \right) \quad (16)$$

as follows:

And the following constraint must be added to the proposed model.

$$y_{jpmch}^1 - y_{jpmch}^2 = x_{(j+1)pmch} - x_{jpmch} \quad \forall j, p, m, c, h \quad (17)$$

Equation (12) is the other case in which the proposed mathematical model is nonlinear. Hence, for linearization, instead of equation (12), equation (18) and (19) are added to the original model as follows:

$$\sum_{m=1}^M \left[(I_{mh}^+ - I_{mh}^-) L_m \right] \leq \left(\sum_{m=1}^M \left(\sum_{c=1}^C N_{mc(h-1)} \right) L_m \right) \lambda_h \quad \forall h \quad (18)$$

$$\sum_{m=1}^M \left[(I_{mh}^- - I_{mh}^+) L_m \right] \leq \left(\sum_{m=1}^M \left(\sum_{c=1}^C N_{mc(h-1)} \right) L_m \right) \lambda_h \quad \forall h \quad (19)$$

4 Robust counterpart mathematical model

In this section, we provide a quick description of the principles of robust optimization. For further details, readers are referred to [44] and references therein. Consider the following linear program (LP):

$$\begin{aligned}
& \min \quad cx \\
& \text{s.t.} \\
& \quad Ax \geq b
\end{aligned} \tag{20}$$

Where $x \in \mathfrak{R}^n$ is the vector of decision variables, $b \in \mathfrak{R}^m$ is the right-hand side parameter vector, $c \in \mathfrak{R}^n$ is the vector of objective function coefficients, and $A \in \mathfrak{R}^{m \times n}$, with elements a_{ij} , is the constraint coefficient matrix.

In a typical problem like (LP), c , A and b are assumed to be deterministic and optimal solution is obtained according deterministic circumstances. Some of the data parameters are considered as uncertain in the Robust Optimization (RO) approach, yet they lie within a set that expresses limits on the uncertainty. The foregoing uncertainty set subsequently defines the limits on uncertainty that a solution will be immunized against. That is, solution x deals with any possible uncertainty lying within the set. In the robust optimization approach the (LP) is transformed into a robust counterpart by replacing each constraint that has uncertain coefficients with a constraint that reflects the incorporation of the uncertainty set. Let \tilde{c}_j , \tilde{a}_{ij} and \tilde{b}_i denote, as an uncertain entry in the objective function coefficients, constraint coefficient and right-hand side parameters, respectively. In the proposed model, each of the uncertain parameters is assumed to vary in a specified closed, bounded box [45],[46],[47]

The general form of this box can be defined as follows:

$$u_{Box} = \left\{ \mathcal{G} \in \mathfrak{R}^n : \left| \mathcal{G}_t - \overline{\mathcal{G}}_t \right| \leq \rho \zeta_t, t = 1, 2, \dots, n \right\} \tag{21}$$

Where $\overline{\mathcal{G}}_t$ is the normal value of \mathcal{G}_t as the t th parameter of vector \mathcal{G} , and where the positive number ζ_t represents the ‘‘uncertainty scale’’ and $\rho > 0$ is the ‘‘uncertainty level’’. A particular case of interest is $\zeta_t = \overline{\mathcal{G}}_t$, which corresponds to a simple case where the box contains \mathcal{G}_t , whose relative deviation from the nominal data is up to ρ .

According to the above description, the robust counterpart of the LP model (22) can be stated as equations (23-26):

Mathematical model:

$$\begin{aligned}
& \min \quad \tilde{c}x + dy \\
& \text{s.t.} \\
& \quad \tilde{a}x \geq b \\
& \quad ey \geq \tilde{f} \\
& \quad x, y \in \{0,1\}
\end{aligned} \tag{22}$$

Robust counterpart mathematical model:

$$\min \quad z \tag{23}$$

$$\tilde{c}_j x_j + dy \leq z \quad \forall \tilde{c}_j \in u_{Box}^c \tag{24}$$

$$\tilde{a}_{ij} x_j \geq b_j \quad \forall \tilde{a}_{ij} \in u_{Box}^a \tag{25}$$

$$e_i y \geq \tilde{f}_i \quad \forall \tilde{f}_i \in u_{Box}^f \tag{26}$$

$$x, y \in \{0,1\}$$

Ben-Tal et al. [46] demonstrate that in a closed bounded box, the robust counterpart problem can be converted to a tractable equivalent model where u_{Box} is replaced by a finite set u_{ext} consisting of the extreme points of u_{Box} . To represent the tractable form of the robust mathematical model, equations (23-26) should be converted to their tractable equivalents. For equation (24) we have:

$$\tilde{c}_j x \leq z - dy, \quad \forall \tilde{c}_j \in u_{Box}^c \mid u_{Box}^c = \left\{ \tilde{c}_j \in \mathfrak{R}^{n_c} : \left| \tilde{c}_j - \bar{c}_j \right| \leq \rho_c \zeta_j^c, j = 1, 2, \dots, n_c \right\} \quad (27)$$

The left-hand side of equation (27) contains the vector of uncertain parameters, while all parameters of the right-hand side are certain. Thus, the tractable form of the above semi-infinite inequality could be written as follows:

$$\begin{aligned} \sum_j (\bar{c}_j x_j + \eta_j) &\leq z - dy, \\ \rho_c \zeta_j^c x_j &\leq \eta_j, \quad \forall j \in \{1, 2, \dots, n_c\}, \\ \rho_c \zeta_j^c x_j &\leq -\eta_j, \quad \forall j \in \{1, 2, \dots, n_c\}, \end{aligned} \quad (28)$$

For a constraint i , $\sum_{j=1}^n \tilde{a}_{ij} x_j \geq b_i$, we only need to augment the left-hand side of the equation to reflect the uncertainty set in the formulation. Formally, in the augmented constraint we require, for a given solution x , that [44],[48]:

$$\min_{a \in u_{Box}^a} \left\{ \sum_{j=1}^n \tilde{a}_{ij} x_j \right\} \geq b_i \quad (29)$$

or

$$\min_{\tilde{a}_{ij} : |\tilde{a}_{ij} - \bar{a}_{ij}| \leq \rho_a \zeta_{ij}^a} \left\{ \sum_{j=1}^n \tilde{a}_{ij} x_j \right\} \geq b_i \quad (30)$$

Given the structure of u_{Box} , the optimal solution of the optimization on the left-hand side is

$$\sum_{j=1}^n \bar{a}_{ij} x_j - \rho_a \sum_{j=1}^n \zeta_{ij}^a |x_j| \geq b_i \quad (31)$$

Which can be reformulated as:

$$\sum_{j=1}^n \bar{a}_{ij} x_j - \rho_a \sum_{j=1}^n \zeta_{ij}^a t_j \geq b_i \quad (32)$$

$$-t_j \leq x_j \leq t_j \quad \forall j (1, 2, \dots, n) \quad (33)$$

Similarly, for inequality (26) we have:

$$e_i y \geq \tilde{f}_i, \quad \forall i \in \{1, 2, \dots, n\}, \forall \tilde{f}_i \in u_{Box}^f \mid u_{Box}^f = \left\{ \tilde{f}_i \in \mathfrak{R}^{n_f} : \left| \tilde{f}_i - \bar{f}_i \right| \leq \rho_f \zeta_i^f, i = 1, 2, \dots, n_f \right\} \quad (34)$$

Thus, it can be rewritten as follows:

$$e_i y \geq \bar{f}_i + \rho_f \zeta_i^f, \quad \forall i \in \{1, 2, \dots, n_f\} \quad (35)$$

According to the above explanation, for developing the robust counterpart of the proposed model, the related machine costs include fixed costs (α_{mh}), variable costs (β_{mh}), relocation costs (δ_{mh}), purchasing costs (φ_{mh}), and sales revenue (ω_{mh}), which are assumed to be uncertain. The other parameters, such as demand of each part (D_{ph}) and time capacity of machines, (T_{mh}) are also of an uncertain nature. Hence, the robust counterpart of the presented DCMS model with uncertain parameters given by box sets is equivalent to the following:

$$\text{Min } Z_1 \quad (36)$$

$$\text{Max } Z_2 = \theta_{jo} \left(\sum_{h=1}^H hi_h - \sum_{h=1}^H fi_h \right) - \theta_{hd} \left(\sum_{h=1}^H \sum_{m=1}^M \sum_{c=1}^C N_{mch} S_m \right) \quad (37)$$

S.t.

$$\begin{aligned} Z_1 \geq & \sum_{h=1}^H \sum_{m=1}^M \sum_{c=1}^C (\bar{\alpha}_{mh} N_{mch} + \eta_{mh}^\alpha) + \sum_{h=1}^H \sum_{m=1}^M \sum_{c=1}^C \sum_{p=1}^P \sum_{j=1}^{O_p} (\bar{\beta}_{ph} \bar{D}_{ph} t_{jpm} x_{jpmch} + \eta_{ph}^D + \eta_{ph}^\beta) \\ & + \frac{1}{2} \sum_{h=1}^H \sum_{p=1}^P \gamma_p^{\text{inter}} \left[\frac{\bar{D}_{ph}}{B_p^{\text{inter}}} \right] \sum_{j=1}^{O_p-1} \sum_{c=1}^C (z_{jpc}^1 + z_{jpc}^2) + \eta_{ph}^D \\ & + \frac{1}{2} \sum_{h=1}^H \sum_{p=1}^P \gamma_p^{\text{intra}} \left[\frac{\bar{D}_{ph}}{B_p^{\text{intra}}} \right] \sum_{j=1}^{O_p-1} \sum_{c=1}^C \left(\sum_{m=1}^M (y_{jpmch}^1 + y_{jpmch}^2) - (z_{jpc}^1 + z_{jpc}^2) \right) + \eta_{ph}^D \quad (38) \\ & + \sum_{h=1}^H \sum_{m=1}^M \sum_{c=1}^C N_{mch} L_m S_m a_{mh}^L + \frac{1}{2} \sum_{h=1}^H \sum_{m=1}^M \sum_{c=1}^C (\bar{\delta}_{mh} (K_{mch}^+ + K_{mch}^-) + \eta_{mh}^\delta) \\ & + \sum_{h=1}^H \sum_{m=1}^M (I_{mh}^+ \bar{\varphi}_{mh} + \eta_{mh}^\varphi) - \sum_{h=1}^H \sum_{m=1}^M (I_{mh}^- \bar{\omega}_{mh} + \eta_{mh}^\omega) \end{aligned}$$

$$\sum_{c=1}^C \sum_{m=1}^M a_{jpm} x_{jpmch} = 1 \quad \forall j, p, h \quad (39)$$

$$x_{jpmch} \leq a_{jpm} \quad \forall j, p, c, m, h \quad (40)$$

$$\sum_{p=1}^P \sum_{j=1}^{O_p} \bar{D}_{ph} t_{jpm} x_{jpmch} + \rho_D \sum_{p=1}^P \sum_{j=1}^{O_p} \zeta_{ph}^D x_{jpmch} \leq \bar{T}_{mh} N_{mch} + \rho_T \xi_{mh}^T N_{mch} \quad \forall m, c, h \quad (41)$$

$$N_{mc(h-1)} + K_{mch}^+ - K_{mch}^- = N_{mch} \quad \forall m, c, h \quad (42)$$

$$\sum_{c=1}^C N_{mc(h-1)} + I_{mh}^+ - I_{mh}^- = \sum_{c=1}^C N_{mch} \quad \forall m, h \quad (43)$$

$$\sum_{m=1}^M N_{mch} \leq UB \quad \forall c, h \quad (44)$$

$$\sum_{m=1}^M N_{mch} \geq LB \quad \forall c, h \quad (45)$$

$$\sum_{m=1}^M I_{mh}^+ L_m \leq hi_h \quad \forall h \quad (46)$$

$$\sum_{m=1}^M I_{mh}^- L_m \leq fi_h \quad \forall h \quad (47)$$

$$\sum_{m=1}^M \left[(I_{mh}^+ - I_{mh}^-) L_m \right] \leq \left(\sum_{m=1}^M \left(\sum_{c=1}^C N_{mc(h-1)} \right) L_m \right) \lambda_h \quad \forall h \quad (48)$$

$$\sum_{m=1}^M \left[(I_{mh}^- - I_{mh}^+) L_m \right] \leq \left(\sum_{m=1}^M \left(\sum_{c=1}^C N_{mc(h-1)} \right) L_m \right) \lambda_h \quad \forall h \quad (49)$$

$$\rho_\alpha \zeta_{mh}^\alpha N_{mch} \leq \eta_{mh}^\alpha \quad \forall m, c, h \quad (50)$$

$$\rho_\alpha \zeta_{mh}^\alpha N_{mch} \geq -\eta_{mh}^\alpha \quad \forall m, c, h \quad (51)$$

$$\rho_\beta \zeta_{ph}^\beta x_{jpmch} \leq \eta_{ph}^\beta \quad \forall j, p, m, c, h \quad (52)$$

$$\rho_\beta \zeta_{ph}^\beta x_{jpmch} \geq -\eta_{ph}^\beta \quad \forall j, p, m, c, h \quad (53)$$

$$\rho_D \zeta_{ph}^D x_{jpmch} \leq \eta_{ph}^D \quad \forall j, p, m, c, h \quad (54)$$

$$\rho_D \zeta_{ph}^D x_{jpmch} \geq -\eta_{ph}^D \quad \forall j, p, m, c, h \quad (55)$$

$$\rho_D \zeta_{ph}^D z_{jpch}^1 \leq \eta_{ph}^D \quad \forall j, p, m, c, h \quad (56)$$

$$\rho_D \zeta_{ph}^D z_{jpch}^1 \geq -\eta_{ph}^D \quad \forall j, p, m, c, h \quad (57)$$

$$\rho_D \zeta_{ph}^D z_{jpch}^2 \leq \eta_{ph}^D \quad \forall j, p, m, c, h \quad (58)$$

$$\rho_D \zeta_{ph}^D z_{jpch}^2 \geq -\eta_{ph}^D \quad \forall j, p, m, c, h \quad (59)$$

$$\rho_D \zeta_{ph}^D y_{jpmch}^1 \leq \eta_{ph}^D \quad \forall j, p, m, c, h \quad (60)$$

$$\rho_D \zeta_{ph}^D y_{jpmch}^1 \geq -\eta_{ph}^D \quad \forall j, p, m, c, h \quad (61)$$

$$\rho_D \zeta_{ph}^D y_{jpmch}^2 \leq \eta_{ph}^D \quad \forall j, p, m, c, h \quad (62)$$

$$\rho_D \zeta_{ph}^D y_{jpmch}^2 \geq -\eta_{ph}^D \quad \forall j, p, m, c, h \quad (63)$$

$$\rho_\delta \zeta_{mh}^\delta K_{mch}^+ \leq \eta_{mh}^\delta \quad \forall m, c, h \quad (64)$$

$$\rho_\delta \zeta_{mh}^\delta K_{mch}^+ \geq -\eta_{mh}^\delta \quad \forall m, c, h \quad (65)$$

$$\rho_\delta \zeta_{mh}^\delta K_{mch}^- \leq \eta_{mh}^\delta \quad \forall m, c, h \quad (67)$$

$$\rho_\delta \zeta_{mh}^\delta K_{mch}^- \geq -\eta_{mh}^\delta \quad \forall m, c, h \quad (68)$$

$$\rho_\phi \zeta_{mh}^\phi I_{mh}^+ \leq \eta_{mh}^\phi \quad \forall m, h \quad (69)$$

$$\rho_\phi \zeta_{mh}^\phi I_{mh}^+ \geq -\eta_{mh}^\phi \quad \forall m, h \quad (70)$$

$$\rho_\omega \zeta_{mh}^\omega I_{mh}^- \leq \eta_{mh}^\omega \quad \forall m, h \quad (71)$$

$$\rho_\omega \zeta_{mh}^\omega I_{mh}^- \geq -\eta_{mh}^\omega \quad \forall m, h \quad (72)$$

$$z_{jpch}^1 - z_{jpch}^2 = \sum_{m=1}^M x_{(j+1)pmch} - \sum_{m=1}^M x_{jpmch} \quad \forall j, p, c, h \quad (73)$$

$$y_{jpmch}^1 - y_{jpmch}^2 = x_{(j+1)pmch} - x_{jpmch} \quad \forall j, p, m, c, h \quad (74)$$

$$x_{jpmch} \in \{0, 1\}, N_{mch}, K_{mch}^+, K_{mch}^-, I_{mh}^+, I_{mh}^-, hi_h, fi_h \geq 0 \text{ and integer}$$

$$z_{jpch}^1, z_{jpch}^2, y_{jpmch}^1, y_{jpmch}^2 \geq 0 \quad (75)$$

$$\eta_{mh}^\alpha, \eta_{ph}^\beta, \eta_{ph}^D, \eta_{mh}^\delta, \eta_{mh}^\phi, \eta_{mh}^\omega \geq 0$$

5 NSGA-II algorithm

Numerous methods have been developed to deal with multi-objective problems. Some of the proposed methods define an integrated objective function based on all objective functions (e.g. weighted sum method) and reach an optimal or near-optimal result. Other methods aim to find a set of solutions

named Pareto solutions. The Optimal Pareto set involves a number of solutions, none of which can completely dominate other Pareto solutions. Non-Dominated Sorting Genetic Algorithm II (NSGA-II) is a meta-heuristic which belongs to evolutionary algorithms and is a commonly used method when there is a problem with more than one goal. This method, first proposed by Deb et al. [49], to find a near-optimal Pareto set. In fact, an initial population is randomly generated and then, for a given number of iterations, new solutions are obtained from existing solutions, per iteration, through crossover and mutation. Employing a crossover operator, two parents are chosen and they produce two new children by combining their characteristics. It should be mentioned that parents' selection is done by a binary tournament selection process. In this process two members are randomly selected and the winner can stay as a parent in our parent set. This is done $2N$ times to choose N parents. In a mutation operation, a member is selected randomly and is changed in some respects.

Here, members of a population are compared with each other in relation to two criteria: rank and crowding distance. Members are sorted and given their own rank. Remember that the solutions of a same rank cannot dominate each other; this means that if two members of the same rank are selected, neither of them is better in all objective functions. On the other hand, crowding distance is a criterion which investigates the diversity of solutions, and high crowding distance is preferred. Of course, crowding distance is a criterion measured for members of a specific rank. Equation (76) explains the way in which crowding distances are measured. In the equation, d_i is the crowding distance of solution i where f_i^r represents the r^{th} objective function value of the i^{th} solution, and f_{\min}^r and f_{\max}^r are minimum and maximum values of the r^{th} objective function, respectively. The crowding distance of the first and last points, the points which have optimum value in at least one objective, is moreover assumed to be infinitive.

$$d_i = \sum_r \frac{f_{i+1}^r - f_{i-1}^r}{f_{\max}^r - f_{\min}^r} \quad (76)$$

5.1 Parameter setting

The NSGA-II algorithm has four vital parameters which should be appropriately tuned before using them to find best results:

- Number of members in a population ($NPop$)
- Number of iterations to find best results ($MaxIt$)
- Crossover rate (CrR)
- Mutation rate (MuR)

As a result, a Taguchi design [50] is employed to set a suitable level for the parameters. Here, we assume three different levels for each parameter:

- $NPop$: 40, 60 and 80
- $MaxIt$: 20, 50 and 100
- CrR : 0.2, 0.5 and 0.8
- MuR : 0.1, 0.2 and 0.3

A response should furthermore be defined for the Taguchi design. Spacing Metric (SM) is a metric used to evaluate Pareto results and is measured by equation (77) where d_i^Q represents the Euclidian distance between two consecutive points (i.e. points i and $i+1$), \bar{d} is their average, and N is the number of members in final non-dominated solutions. An algorithm with more SM is preferred.

$$SM = \frac{\sum_{i=1}^{N-1} |\bar{d} - d_i^o|}{(N-1)\bar{d}} \quad (77)$$

Distance to an ideal point (D2P) is another metric which calculates the average Euclidian distance of the Pareto results from an ideal point in the space (e.g. Fig 2). Of course, the ideal point is selected by decision makers.

{Please insert Fig. 2 here.}

Computational time is also an important criterion of a method. As a result, the table of the Taguchi design is done with Minitab software (version 16), and best levels of parameters are selected as represented in Tables 2 and 3 and Fig 3. Table 2 displays responses in the experiments. Regarding the same importance of three responses, normalization is used to convert all values to a number in the range [0 1]. Based on these experiments, Fig 3. serves as a graphic tool to choose the best levels for the considered parameters. In fact, level 1 of *NPop*, i.e. 40, level 2 of *MaxIt*, i.e. 50, level 3 of *CrR*, i.e. 0.8, and level 3 of *MuR*, i.e. 0.3, have been determined as best levels for the parameters.

{Please insert Table 2 here.}

{Please insert Table 3 here.}

{Please insert Fig. 3 here.}

6 Computational results

Some numeric examples have to be generated in order to evaluate the performance of the proposed robust mathematical model. Three sets of examples are therefore generated, based on the pattern in Table 4, in different sizes named S1, S2 and S3, respectively, shown in Table 5. On the other hand, the uncertainty levels for all parameters are the same (i.e. $\rho_\alpha = \rho_\beta = \rho_D = \rho_\delta = \rho_\phi = \rho_\omega$) and take three different values: 0.25, 0.50 and 0.75. On each uncertainty level, five problems are derived from S1, S2 and S3 with different amounts of uncertain data, subject to their range of deviation from nominal levels. This action is taken into account to simulate five different possible states of a case and to solve all of them, in order to assess the performance of the proposed models. This operation could actually be called realization. All deterministic and robust problems are solved by the NSGA-II algorithm, using Matlab software (version 2012a) on a Core 2 Duo Notebook, 2.67 GHz with 4 GB RAM. Some of these patterns are taken from Safaei et al. [16], while others are generated for our problem.

{Please insert Table 4 here.}

{Please insert Table 5 here.}

{Please insert Table 6 here.}

{Please insert Table 7 here.}

A set of solutions, called Pareto results, is predictably obtained after running NSGA-II. A Pareto set, as mentioned above, involves a number of non-dominated solutions. This means that each result is better than at least one other result in the Pareto set, considering an objective function, and is worse than that, considering another objective function. In all Pareto sets of bi-objective problems, there are two important points: one with an optimum level for one objective, and one with an optimum level for another objective. Tables 6 and 7 report the best solutions obtained for Z_1 and Z_2 , respectively. Fig. 4. and Fig. 5. illustrate the difference between the robust and deterministic models in the second size, S2. Each block presents the mean (horizontal line), the standard deviation (internal rectangle), and the max and min value of the objective function (external rectangle). The results demonstrate that the proposed robust model is worse than the deterministic model because in robust optimization all uncertain parameters are considered as worst cases in practice, in order to obtain lower risks and to limit loss as far as possible. While, the robust model is able to reach appropriate solutions in all sizes and at all considered levels of uncertainty, while the deterministic model is probably unfeasible when the level of uncertainty is increased. Moreover, the deterministic model could find better solutions than the robust one when, with the latter, the first objective function is more important and the second objective function is well maximized. However, based on Fig. 4 and Fig. 5, we find that the results of the robust model have higher values of the objective function but a lower standard deviation in comparison with the deterministic model in all uncertainty levels. In other words, low standard deviation of robust results is another reason to demonstrate the efficiency of the proposed model. In fact, as Fig. 4. and Fig. 5. show, there are six comparisons between deterministic and robust results, by which it could be found that most comparisons represent the lower deviation of robust results. However, there are some comparisons which show that the deterministic model could obtain closer solutions. The preference of the deterministic model in some cases (e.g. for an uncertainty level of 0.75 in Fig. 4 and an uncertainty level of 0.25 in Fig. 5) with lower deviation is explained by the use of meta-heuristics, whereby near-optimum solutions are reached rather than optimum ones.

{Please insert Fig. 4 here.}

{Please insert Fig. 5 here.}

Table 8 shows the computational times of the solved problems. It is worth mentioning that the robust model contains more constraints, decision variables and parameters. It is therefore expected that computational times in a meta-heuristic algorithm will be longer in the robust model than in the deterministic model.

{Please insert Table 8 here.}

7 Conclusion and future research

This paper addresses a new DCMS problem by considering social responsibility issues, and introduces a new robust optimization model for dealing with uncertain parameters that are neglected in the literature. First a multi-objective mathematical model is developed, in which the first objective function minimizes related costs of problems, including machine and labor costs. The social aspect, consisting of job opportunities and occupational safety, is maximized by the second objective function. In the proposed model, in order to reduce its complexity, we take into account only two social criteria, even though this model is able to integrate more criteria, such as job severity, occupational diseases, and labor days lost due to injury, in the second objective function.

In order to increase the capability of the proposed model to deal with uncertain data such as machine costs, demand for parts, and machine time capacity, a robust optimization approach is presented. A number of examples are generated and solved by employing a Non-Dominated Sorting Genetic Algorithm (NSGA-II). In our study, three test problems were examined in different states of uncertainty, which meant that each of the based examples was used to generate various problems under uncertain parameters. The results illustrate the supremacy of the robust model in the handling of uncertain parameters and in the robustness of relevant solutions in comparison with the deterministic model. By way of explanation, in contrast to the deterministic model, the robust model could obtain suitable solutions for all levels of uncertainty. Moreover, the results demonstrate the low deviation of the robust model in comparison with the deterministic one.

For the extension of current research, other social and environmental issues can be considered, such as job severity, occupational diseases, labor days lost due to injury, waste of energy, CO₂ emissions, etc. Additionally, various uncertain parameters and possibilistic approaches can be applied in future research.

Acknowledgment

The authors gratefully acknowledge the scientific and financial supports of ARC 8 of Region Rhône-Alpes, France in developing this paper.

References

- [1] J. M. Cruz and T. Wakolbinger, "Multiperiod effects of corporate social responsibility on supply chain networks, transaction costs, emissions, and risk," *Int. J. Prod. Econ.*, vol. 116, no. 1, pp. 61–74, Nov. 2008.
- [2] K. M. Amaeshi, O. K. Osuji, and P. Nnodim, "Corporate Social Responsibility in Supply Chains of Global Brands: A Boundaryless Responsibility? Clarifications, Exceptions and Implications," *J. Bus. Ethics*, vol. 81, no. 1, pp. 223–234, 2008.
- [3] C. R. Carter and M. M. Jennings, "Social responsibility and supply chain relationships," *Transp. Res. Part E Logist. Transp. Rev.*, vol. 38, no. 1, pp. 37–52, Jan. 2002.
- [4] SAI, "Social Accountability 8000 International Standards," *SAI, New York*, 2001.
- [5] ISO, "Final Draft International standard ISO/FDIS 26000," *Guid. Soc. Responsib.*, 2010.

- [6] GRI, "Sustainability Reporting Guidelines," *version 3.1. Available*, 2011.
- [7] National Institute of Occupational Safety and Health (NIOSH), "Criteria for a recommended standard: occupational noise exposure," *Dep. Heal. Hum. Serv. Washington, DC*, pp. 98–126, 1998.
- [8] M. Rheault, J. R. Drolet, and G. Abdalnour, "Physically reconfigurable virtual cells: A dynamic model for a highly dynamic environment," *Comput. Ind. Eng.*, vol. 29, no. 1–4, pp. 221–225, Sep. 1995.
- [9] J. Schaller, S. Selçuk Erengüç, and A. Vakharia, "A methodology for integrating cell formation and production planning in cellular manufacturing," *Ann. Oper. Res.*, vol. 77, no. 0, pp. 1–21, 1998.
- [10] M. Chen and D. Cao, "Coordinating production planning in cellular manufacturing environment using Tabu search," *Comput. Ind. Eng.*, vol. 46, no. 3, pp. 571–588, Jun. 2004.
- [11] R. Tavakkoli-Moghaddam, M. B. Aryanezhad, N. Safaei, and A. Azaron, "Solving a dynamic cell formation problem using metaheuristics," *Appl. Math. Comput.*, vol. 170, no. 2, pp. 761–780, Nov. 2005.
- [12] R. Tavakkoli-moghaddam, N. Safaei, and M. Babakhani, "Solving a Dynamic Cell Formation Problem with Machine Cost and Alternative Process Plan by Memetic Algorithms," in *Stochastic Algorithms: Foundations and Applications*, 2005, pp. 213–227.
- [13] F. M. Defersha and M. Chen, "A comprehensive mathematical model for the design of cellular manufacturing systems," *Int. J. Prod. Econ.*, vol. 103, no. 2, pp. 767–783, Oct. 2006.
- [14] N. Safaei, M. Saidi-Mehrabad, and M. Babakhani, "Designing cellular manufacturing systems under dynamic and uncertain conditions," *J. Intell. Manuf.*, vol. 18, no. 3, pp. 383–399, 2007.
- [15] N. Safaei, M. Saidi mehrabad, and R. Tavakkoli moghaddam, "A fuzzy programming approach for a cell formation problem with dynamic and uncertain conditions," *Fuzzy sets Syst.*, vol. 159, pp. 215–236, 2008.
- [16] N. Safaei, M. Saidi mehrabad, and M. S. Jabal Ameli, "A hybrid simulated annealing for solving an extended model of dynamic cellular manufacturing system," *Eur. J. Oper. Res.*, vol. 185, pp. 563–592, 2008.
- [17] F. M. Defersha and M. Chen, "A linear programming embedded genetic algorithm for an integrated cell formation and lot sizing considering product quality," *Eur. J. Oper. Res.*, vol. 187, no. 1, pp. 46–69, May 2008.
- [18] M. B. Aryanezhad, V. Deljoo, and S. M. J. Mirzapour Al-e-hashem, "Dynamic cell formation and the worker assignment problem: a new model," *Int. J. Adv. Manuf. Technol.*, vol. 41, no. 3–4, pp. 329–342, 2009.
- [19] N. Safaei and R. Tavakkoli-Moghaddam, "Integrated multi-period cell formation and subcontracting production planning in dynamic cellular manufacturing systems," *Int. J. Prod. Econ.*, vol. 120, no. 2, pp. 301–314, Aug. 2009.

- [20] M. Aramoon Bajestani, M. Rabbani, A. R. Rahimi-Vahed, and G. Baharian Khoshkhou, "A multi-objective scatter search for a dynamic cell formation problem," *Comput. Oper. Res.*, vol. 36, no. 3, pp. 777–794, Mar. 2009.
- [21] X. Wang, J. Tang, and K. Yung, "Optimization of the multi-objective dynamic cell formation problem using a scatter search approach," *Int. J. Adv. Manuf. Technol.*, pp. 318–329, 2009.
- [22] V. Deljoo, S. M. J. Mirzapour Al-e-hashem, F. Deljoo, and M. B. Aryanezhad, "Using genetic algorithm to solve dynamic cell formation problem," *Appl. Math. Model.*, vol. 34, no. 4, pp. 1078–1092, Apr. 2010.
- [23] I. Mahdavi, A. Aalaei, M. M. Paydar, and M. Solimanpur, "Designing a mathematical model for dynamic cellular manufacturing systems considering production planning and worker assignment," *Comput. Math. with Appl.*, vol. 60, no. 4, pp. 1014–1025, Aug. 2010.
- [24] N. Javadian, A. Aghajani, J. Rezaeian, and M. Ghaneian Sebdani, "A multi-objective integrated cellular manufacturing systems design with dynamic system reconfiguration," *Int. J. Adv. Manuf. Technol.*, vol. 56, no. 1–4, pp. 307–317, 2011.
- [25] K. Rafiee, M. Rabbani, H. Rafiei, and A. Rahimi-Vahed, "A new approach towards integrated cell formation and inventory lot sizing in an unreliable cellular manufacturing system," *Appl. Math. Model.*, vol. 35, no. 4, pp. 1810–1819, Apr. 2011.
- [26] L. Saxena and P. Jain, "Dynamic cellular manufacturing systems design—a comprehensive model," *Int. J. Adv. Manuf. Technol.*, vol. 53, no. 1–4, pp. 11–34, 2011.
- [27] R. Kia, A. Baboli, N. Javadian, R. Tavakkoli-moghaddam, M. Kazemi, and J. Khorrami, "Solving a group layout design model of a dynamic cellular manufacturing system with alternative process routings, lot splitting and flexible reconfiguration by simulated annealing," *Comput. Oper. Res.*, vol. 39, no. 11, pp. 2642–2658, 2012.
- [28] H. Rafiei and R. Ghodsi, "A bi-objective mathematical model toward dynamic cell formation considering labor utilization," *Appl. Math. Model.*, vol. 37, no. 4, pp. 2308–2316, Feb. 2013.
- [29] V. Majazi Dalfard, "New mathematical model for problem of dynamic cell formation based on number and average length of intra and intercellular movements," *Appl. Math. Model.*, vol. 37, no. 4, pp. 1884–1896, Feb. 2013.
- [30] B. Javadi, F. Jolai, J. Slomp, M. Rabbani, and R. Tavakkoli-Moghaddam, "A hybrid electromagnetism-like algorithm for dynamic inter/intra-cell layout problem," *Int. J. Comput. Integr. Manuf.*, Mar. 2014.
- [31] A. Aghajani, S. A. Didehbani, M. Zadahmad, M. H. Seyedrezaei, and O. Mohsenian, "A multi-objective mathematical model for cellular manufacturing systems design with probabilistic demand and machine reliability analysis," *Int. J. Adv. Manuf. Technol.*, vol. 75, no. 5–8, pp. 755–770, Aug. 2014.
- [32] B. Bootaki, I. Mahdavi, and M. M. Paydar, "New bi-objective robust design-based utilisation towards dynamic cell formation problem with fuzzy random demands," *Int. J. Comput. Integr. Manuf.*, pp. 1–16, Feb. 2014.

- [33] M. M. Paydar and M. Saidi-Mehrabad, "Revised multi-choice goal programming for integrated supply chain design and dynamic virtual cell formation with fuzzy parameters," *Int. J. Comput. Integr. Manuf.*, vol. 28, no. 3, pp. 251–265, Jan. 2014.
- [34] P. Renna and M. Ambrico, "Design and reconfiguration models for dynamic cellular manufacturing to handle market changes," *Int. J. Comput. Integr. Manuf.*, vol. 28, no. 2, pp. 170–186, Feb. 2014.
- [35] D. Cao and M. Chen, "A robust cell formation approach for varying product demands," *Int. J. Prod. Res.*, vol. 43, no. 8, pp. 1587–1605, Apr. 2005.
- [36] F. M. Defersha and M. Chen, "Machine cell formation using a mathematical model and a genetic-algorithm-based heuristic," *Int. J. Prod. Res.*, vol. 44, no. 12, pp. 2421–2444, Jun. 2006.
- [37] F. M. Defersha and M. Chen, "A parallel genetic algorithm for dynamic cell formation in cellular manufacturing systems," *Int. J. Prod. Res.*, vol. 46, no. 22, pp. 6389–6413, Oct. 2008.
- [38] S. Ahkioon, A. A. Bulgak, and T. Bektas, "Cellular manufacturing systems design with routing flexibility, machine procurement, production planning and dynamic system reconfiguration," *Int. J. Prod. Res.*, vol. 47, no. 6, pp. 1573–1600, Dec. 2008.
- [39] J. M. Cruz and Z. Liu, "Modeling and analysis of the multiperiod effects of social relationship on supply chain networks," *Eur. J. Oper. Res.*, vol. 214, no. 1, pp. 39–52, Oct. 2011.
- [40] A. Iacovides, K. Fountoulakis, S. Kaprinis, and G. Kaprinis, "The relationship between job stress, burnout and clinical depression," *J. Affect. Disord.*, vol. 75, no. 3, pp. 209–221, Aug. 2003.
- [41] M. B. Aryanezhad, A. S. Kheirkhah, V. Deljoo, and S. M. J. Mirzapour Al-e-hashem, "Designing safe job rotation schedules based upon workers' skills," *Int. J. Adv. Manuf. Technol.*, vol. 41, no. 1–2, pp. 193–199, Mar. 2008.
- [42] F. Dehghanian and S. Mansour, "Designing sustainable recovery network of end-of-life products using genetic algorithm," *Resour. Conserv. Recycl.*, vol. 53, no. 10, pp. 559–570, Aug. 2009.
- [43] A. Boggia and C. Cortina, "Measuring sustainable development using a multi-criteria model: A case study," *J. Environ. Manage.*, vol. 91, no. 11, pp. 2301–2306, Nov. 2010.
- [44] A. Ben-Tal, L. El-Ghaoui, and A. Nemirovski, *Robust Optimization*. New Jersey, USA: Princeton University Press, 2009, pp. 7–23.
- [45] A. Ben-Tal and A. Nemirovski, "Robust Solutions of Uncertain Linear Programs," *Oper. Res. Lett.*, no. 1, pp. 1–16, 1999.
- [46] A. Ben-Tal, B. Golany, A. Nemirovski, and J.-P. Vial, "Retailer-Supplier Flexible Commitments Contracts: A Robust Optimization Approach," *Manuf. Serv. Oper. Manag.*, vol. 7, no. 3, pp. 248–271.
- [47] M. S. Pishvaei, M. Rabbani, and S. A. Torabi, "A robust optimization approach to closed-loop supply chain network design under uncertainty," *Appl. Math. Model.*, vol. 35, no. 2, pp. 637–649, Feb. 2011.

- [48] O. Baron, J. Milner, and H. Naseraldin, "Facility Location: A Robust Optimization Approach," *Prod. Oper. Manag.*, vol. 20, no. 5, pp. 772–785, 2011.
- [49] K. Deb, A. Pratap, S. Agarwal, and T. Meyarivan, "A fast and elitist multiobjective genetic algorithm: NSGA-II," *Evolutionary Computation, IEEE Transactions on*, vol. 6, no. 2, pp. 182–197, 2002.
- [50] P. Chatsirungruang, "Application of genetic algorithm and Taguchi method in dynamic robust parameter design for unknown problems," *Int. J. Adv. Manuf. Technol.*, vol. 47, no. 9–12, pp. 993–1002, 2010.

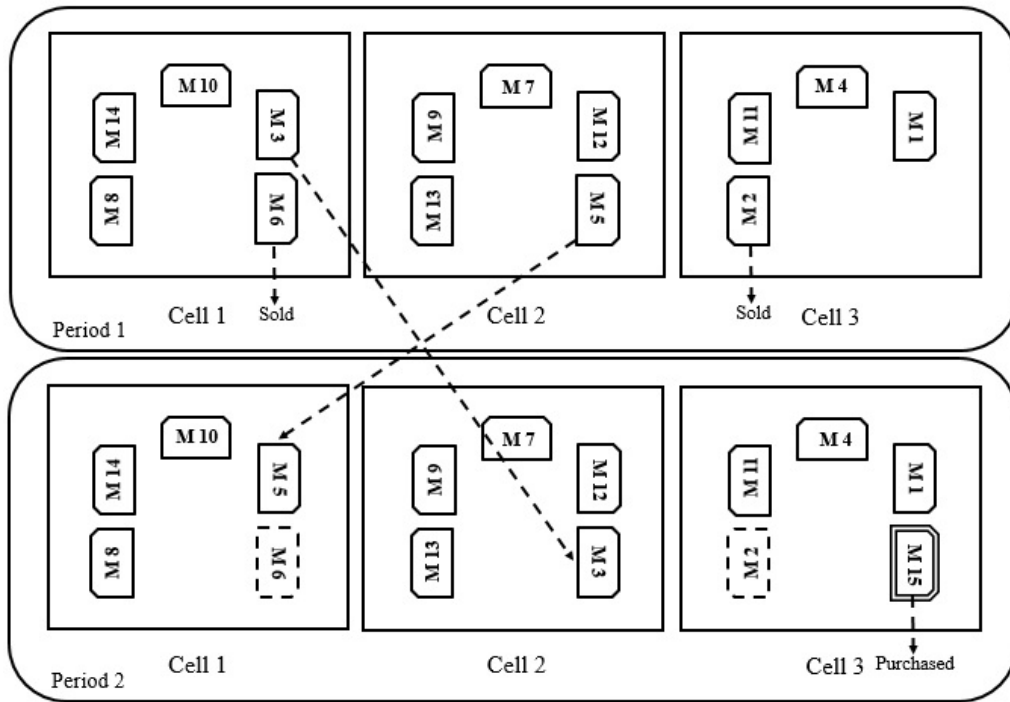

Fig. 1. A schematic view of dynamic cellular manufacturing

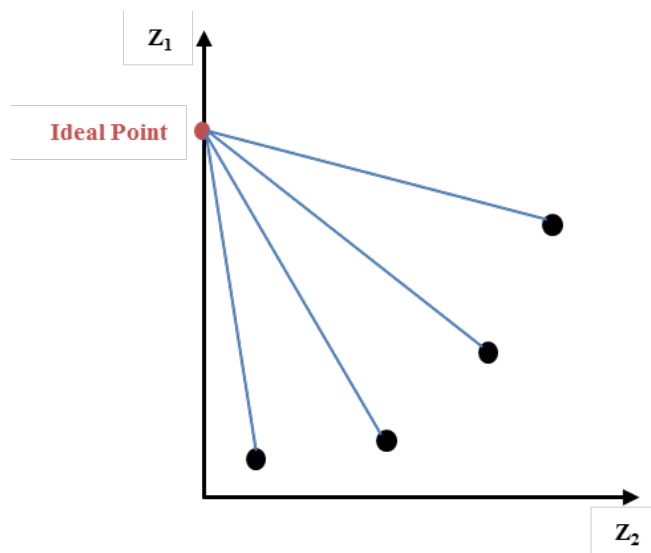

Fig. 2. Distance of Pareto solutions from an ideal point

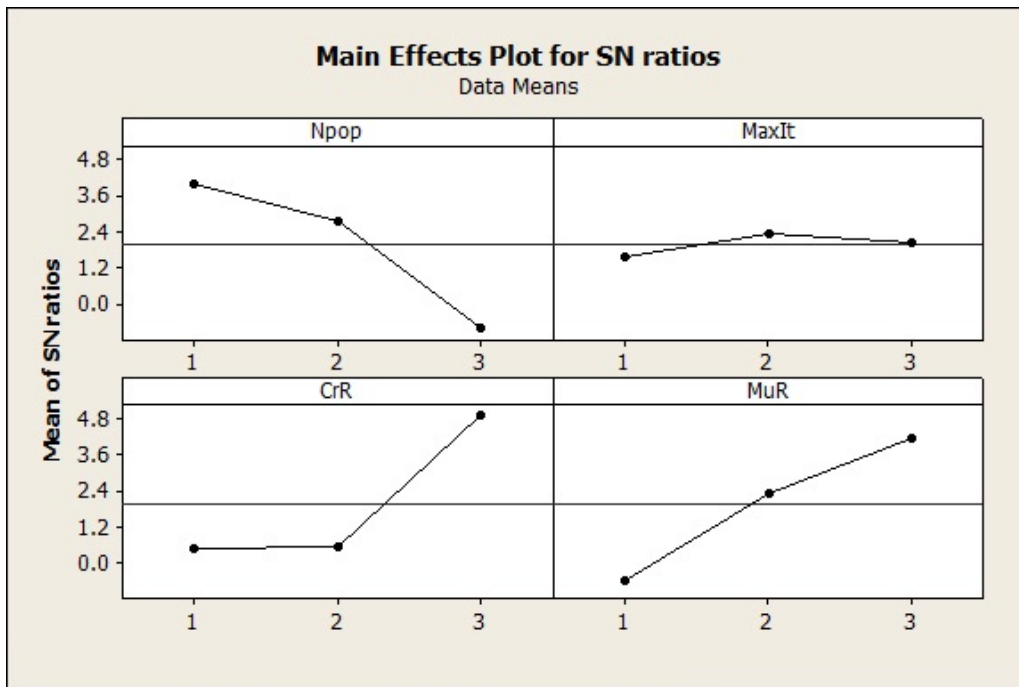

Fig. 3. Signal to noise ratio from Taguchi experiments

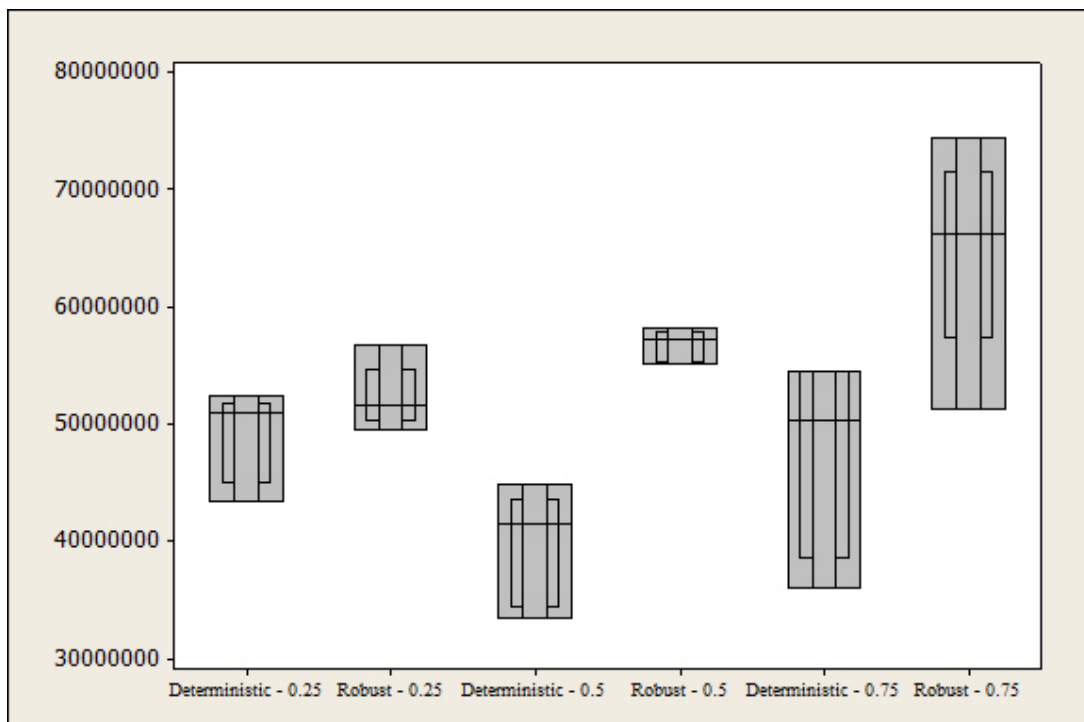

Fig. 4. Best results of Z_l for S2

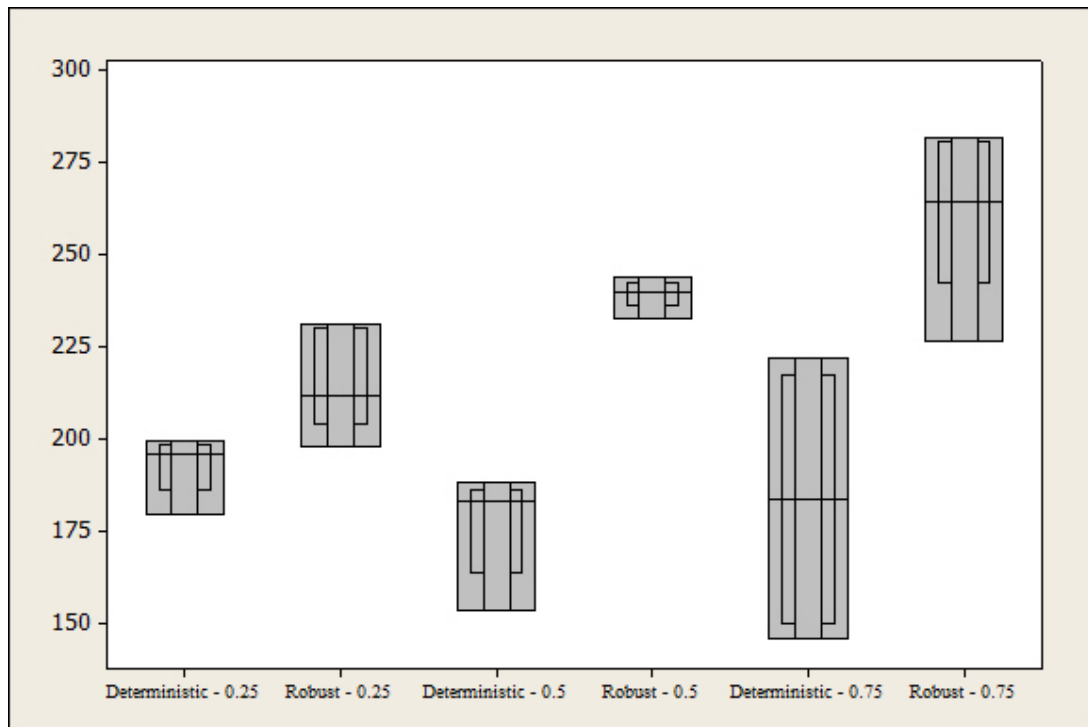

Fig. 5. Best results of Z_2 for S2

Author	Objective function	Economic criteria*			Labor utilization	Data Nature	Solving Method	Parts Movement Aspect
		Production cost	Configuration cost	Labor cost				
Rheault et al. [8]	Single		✓			Certain	heuristic	inter-cell
Schaller et al. [9]	Single	✓				Certain	Lagrangian relaxation	inter-cell
Chen & Cao [10]	Single		✓			Probabilistic	TS	inter-cell
Tavakkoli-Moghaddam et al. [11]	Single		✓			Certain	GA,TS,SA	inter-cell
Tavakkoli-Moghaddam et al. [12]	Single		✓			Certain	MA	inter-cell
Defersha & Chen [13]	Single	✓	✓			Certain	Exact (LINGO)	inter-cell
Safaei et al. [14] [15]	Single	✓	✓			Fuzzy	B&B	inter/intra-cell
Safaei et al. [16]	Single	✓	✓			Certain	MFA-SA	inter/intra-cell
Defersha & Chen [17]	Single	✓	✓			Certain	GA	inter-cell
Aryanezhad et al. [18]	Single	✓	✓			Certain	Exact (CPLEX)	inter-cell
Safaei & Tavakkoli- Moghaddam [19]	Single	✓	✓			Certain	B&B	inter /intra-cell
Aramoon Bajestani et al. [20]	Multi	✓	✓			Certain	MOSS	inter-cell
Wang et al. [21]	Multi		✓			Certain	SS	inter-cell
Deljoo et al. [22]	Single	✓	✓			Certain	GA	inter-cell
Mahdavi et al. [23]	Single	✓	✓			Certain	Exact (LINGO)	inter-cell
Rafiee et al. [25]	Single	✓	✓			Certain	PSO	Inter/intra-cell
Saxena & Jain [26]	Single	✓				Certain	LINGO	inter/intra-cell
Kia et al. [27]	Single	✓	✓			Certain	GA	inter/intra-cell
Rafiei & Ghodsi [28]	Multi	✓	✓	✓	✓	Certain	Hybrid of ACO-GA	inter/intra-cell
Majazi Dalfard [29]	Single		✓			Certain	SA embedded in B&C	inter/intra-cell
Javadi et al. [30]	Single		✓			Certain	EM-like	inter/intra-cell
Aghajani et al. [31]	Multi	✓	✓			Probabilistic	NSGA-II	inter/intra-cell
Bootaki et al. [32]	Multi		✓		✓	Fuzzy	Goal programming	inter-cell
Paydar and Saidi-Mehrabad [33]	Multi	✓	✓			Possibilistic	Goal programming	inter-cell
Renna and Ambrico [34]	Single		✓			Probabilistic	Exact (LINGO)	inter-cell

* (Production cost): fixed and variable cost of machine, inventory cost
(Configuration cost): machine relocation cost, machine procurement cost

Table 1 Classification of literature about DCMS

Experiment	Coded levels				Uncoded levels			
	Npop	MaxIt	Cr	Mu	Npop	MaxIt	Cr	Mu
1	1	1	1	1	40	20	0.2	0.1
2	1	2	2	2	40	50	0.5	0.2
3	1	3	3	3	40	100	0.8	0.3
4	2	1	2	3	60	20	0.5	0.3
5	2	2	3	1	60	50	0.8	0.1
6	2	3	1	2	60	100	0.2	0.2
7	3	1	3	2	80	20	0.8	0.2
8	3	2	1	3	80	50	0.2	0.3
9	3	3	2	1	80	100	0.5	0.1

Table 2 Experiments of the Taguchi design

Experiments	Real values			Normalized values		
	SM	D2P	Time (s)	SM	D2P	Time (s)
1	0.921	10003360428	34.167	0.431	1	0
2	0.897	9996648391	209.943	0.373	0.636	0.118
3	1.069	9994073131	673.243	0.805	0.496	0.43
4	1.058	9995545657	198.928	0.778	0.576	0.111
5	0.777	9988679715	552.402	0.07	0.204	0.349
6	0.785	9996204858	425.263	0.088	0.612	0.263
7	0.757	9990439112	500.821	0.019	0.299	0.314
8	1.146	9986893557	515.639	1	0.107	0.324
9	0.75	9984924763	1520.5	0	0	1

Table 3 Obtained responses of Taguchi experiments

Parameter	Generation pattern
D_{ph}	\sim Uniform (100, 1000)
B_p^{inter}	\sim Uniform (10, 50)
B_p^{intra}	$B_p^{inter} / 5$
γ_p^{inter}	\sim Uniform (1, 30)
γ_p^{intra}	\sim Uniform (1, 30)
α_{mh}	\sim Uniform (1000, 2000)
β_{mh}	\sim Uniform (1, 10)
δ_{mh}	$\alpha_{mh} / 2$
T_{mh}	\sim Uniform (1, 5)
UB	6
LB	2
L_m	\sim Uniform (1, 8)
φ_{mh}	\sim Uniform (1000, 5000)
ω_{mh}	\sim Uniform (0, 1) $\times \varphi_{mh}$
S_m	\sim Uniform (0, 1)
λ_h	\sim Uniform (0, 1)
sa_{mh}^L	\sim Uniform (50, 75)
t_{jpm}	\sim Uniform (1, 10)

Table 4 Pattern of sample generation

	S1	S2	S3
$ O_p \times P \times M \times C \times H $	$3 \times 3 \times 4 \times 3 \times 2$	$6 \times 6 \times 7 \times 5 \times 4$	$8 \times 8 \times 9 \times 6 \times 5$

Table 5 Different sizes of problems

		Deterministic		Robust		
		Z ₁	Z ₂	Z ₁	Z ₂	
$\rho = 0.25$	S1	1	2060152.047	2.298	3969828.543	5.576
		2	2817647.19	6.1729	3509775.811	8.472
		3	2210973.77	2.792	3858171.512	5.035
		4	3328183.943	2.568	4951873.559	9.731
		5	3227828.209	6.308	4079282.307	7.638
	S2	1	52397144.58	11.112	51645075.02	12.444
		2	50929235.04	13.349	49585007.78	11.376
		3	43446369.88	10.725	51015775.08	13.964
		4	46511081.63	11.492	56762119.88	15.304
		5	51324191.58	14.484	52640809.24	12.878
	S3	1	Infeasible	Infeasible	130682131.9	26.795
		2	Infeasible	Infeasible	127053558.4	26.109
		3	Infeasible	Infeasible	139439766.5	29.318
		4	158126369.4	31.328	133304620.6	27.144
		5	145392597.4	25.644	129728057.2	24.946
$\rho = 0.50$	S1	1	1533608.95	2.009	3481689.56	2.068
		2	3384264.888	4.847	5025683.047	6.759
		3	2783557.22	3.302	5353712.626	5.087
		4	1824289.798	3.291	3231658.229	7.844
		5	1643472.424	1.439	5049564.677	10.615
	S2	1	33447983.78	9.366	58145649.45	15.771
		2	41522784.35	10.483	57491016.65	14.984
		3	44879080.15	11.941	57229791.32	15.743
		4	42390396.25	9.517	55506872.72	14.359
		5	35466965.22	8.799	55233404.07	14.511
	S3	1	Infeasible	Infeasible	137158768.8	26.207
		2	158828320.2	28.383	136221613.4	26.245
		3	Infeasible	Infeasible	160363246.6	30.289
		4	172310552.5	32.35	144875052.9	28.409
		5	152058111.5	27.463	140746973.3	27.12
$\rho = 0.75$	S1	1	3103390.005	2.488	5309200.308	9.064
		2	2256637.887	3.214	4692328.174	2.415
		3	2299605.933	3.949	4387337.881	8.488
		4	2944939.769	4.776	6721649.424	13.588
		5	1842341.824	2.982	3445643.678	2.267
	S2	1	54402305.04	11.289	68658803.71	19.284
		2	Infeasible	Infeasible	63567388.11	16.685
		3	54493461.49	13.346	66275690.62	17.785
		4	36131036.71	7.866	51240167.22	13.064
		5	46308241.75	10.08	74419317.06	17.68
	S3	1	Infeasible	Infeasible	162653027.6	31.354
		2	Infeasible	Infeasible	161786933.5	31.758
		3	Infeasible	Infeasible	150016398.3	31.526
		4	Infeasible	Infeasible	164223732.7	31.244
		5	Infeasible	Infeasible	147613662	32.015

Table 6 Objective functions value with best Z₁ in final Pareto results

		Deterministic		Robust		
		Z ₁	Z ₂	Z ₁	Z ₂	
$\rho = 0.25$	S1	1	8754495.995	22.466	8052327.457	20.838
		2	6908261.096	19.23	7315716.184	21.061
		3	7866827.803	19.794	12274043.99	24.567
		4	9520855.238	20.985	8325079.542	21.862
		5	6756378.563	18.934	8954907.277	24.052
	S2	1	77909945.1	195.836	79277216.27	211.592
		2	77111769.43	192.337	84780633.65	228.818
		3	66841833.63	179.589	72011777.22	209.990
		4	75987695.73	197.336	81542885.38	231.031
		5	67570577.73	199.618	63376425.69	197.675
	S3	1	Infeasible	Infeasible	179016979.1	396.233
		2	Infeasible	Infeasible	186232041.9	397.4183
		3	Infeasible	Infeasible	180777164.1	410.16735
		4	182781896.4	380.913	167776446.6	377.61048
		5	198087733	382.255	171878867.6	364.0492
$\rho = 0.50$	S1	1	7947074.394	19.764	7902448.414	21.681
		2	11575765.43	29.852	11950406.63	25.483
		3	8944049.478	16.654	12333551.09	23.192
		4	4595541.273	15.388	7024440.88	21.841
		5	4396903.496	14.431	9833181.338	26.866
	S2	1	74385259.9	188.367	85857450.43	239.501
		2	67801283.87	174.3761	93747776.57	243.903
		3	71363586.18	183.426	82361563.93	232.719
		4	64996306.38	153.374	83582231.93	239.931
		5	64455603.07	183.208	89842825.5	241.261
	S3	1	Infeasible	Infeasible	192315126.2	408.985
		2	224139966.6	428.385	196541829.3	423.739
		3	Infeasible	Infeasible	215277385.5	468.27
		4	192048328.9	353.183	195250678	420.575
		5	215198051.6	372.967	181121899.1	391.303
$\rho = 0.75$	S1	1	8925452.973	24.941	10563626.35	29.854
		2	7319703.219	20.395	11361483.47	27.281
		3	12143392.35	28.438	8937980.168	29.798
		4	9339241.583	20.563	14584946.98	35.799
		5	5212238.84	12.288	8663060.137	19.786
	S2	1	72335438.41	162.589	87826885.85	258.516
		2	Infeasible	Infeasible	100359058.4	264.211
		3	86370932.99	221.959	96011762.26	281.821
		4	62184179.47	145.705	81592600.49	226.414
		5	86072370.65	204.311	110391114	279.322
	S3	1	Infeasible	Infeasible	223630224	483.155
		2	Infeasible	Infeasible	211832468.2	451.861
		3	Infeasible	Infeasible	226999065	494.931
		4	Infeasible	Infeasible	203310318	444.501
		5	Infeasible	Infeasible	203836403.6	448.986

Table 7 Objective functions value with best Z₂ in final Pareto results

	$\rho = 0.25$		$\rho = 0.50$		$\rho = 0.75$	
	Deterministic	Robust	Deterministic	Robust	Deterministic	Robust
S1	2.845	5.377	2.851	5.66	2.836	5.808
S2	72.143	127.145	71.831	125.077	72.356	124.255
S3	368.323	614.43	352.78	617.599	-	607.002

Table 8 Computational times (Second)