

Microreactors to measure solubilities in the CO₂-H₂O-NaCl system.

Marie-Camille CAUMON, Jean DUBESSY, Pascal ROBERT, Boubaker BENAÏSSA
GeoResources laboratory, Vandœuvre-lès-Nancy, France

OBJECTIVES & METHODS

Context

- Prevision of the effects of CO₂ injection in saline aquifers:
- Lack of solubility data in saline media at high *PT*.
 - Measurements without sampling = no perturbations.

Objectives

- Acquisition of solubility data in saline media by *in situ* Raman techniques at 25-250 °C, 0-500 bar, 0-4 M NaCl.
- Raman data processing selection.

Methods

- A fused silica microreactor connected to a pressurization device and placed on a heating-cooling stage is filled with saline water and CO₂.
- Solubility is measured by Raman spectroscopy and compared to the calculated one (EOS Duan and Sun 2003).

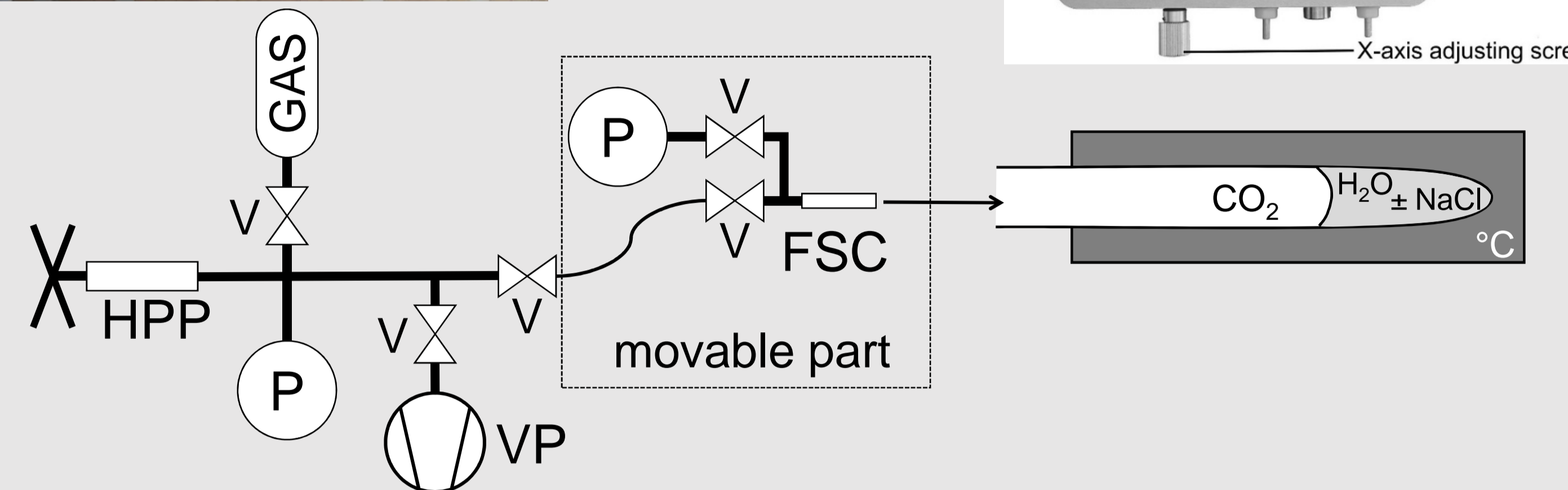
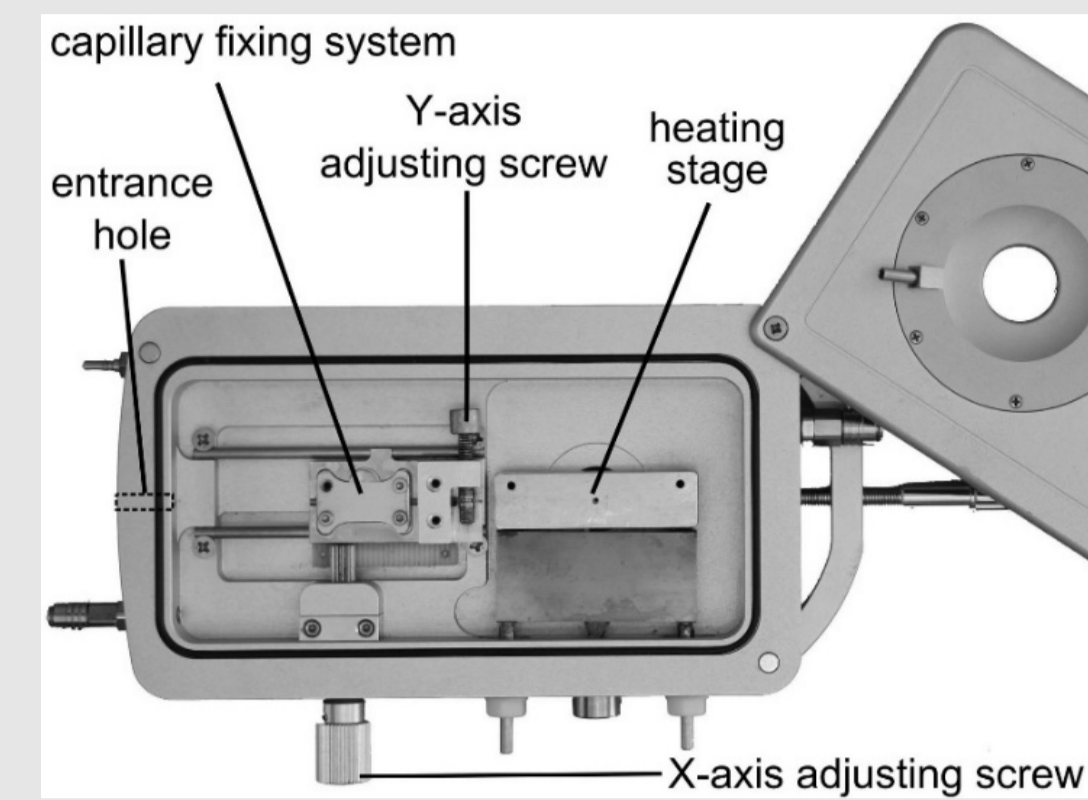

The **HPOC** setup: a pressure controlling system connected to a fused silica capillary (FSC) placed on a heating-cooling stage (CAP500, Linkam) and coupled with a Raman microspectrometer (Labram HR, Horiba Jobin Yvon).

RESULTS

Effect of salinity & Raman data processing

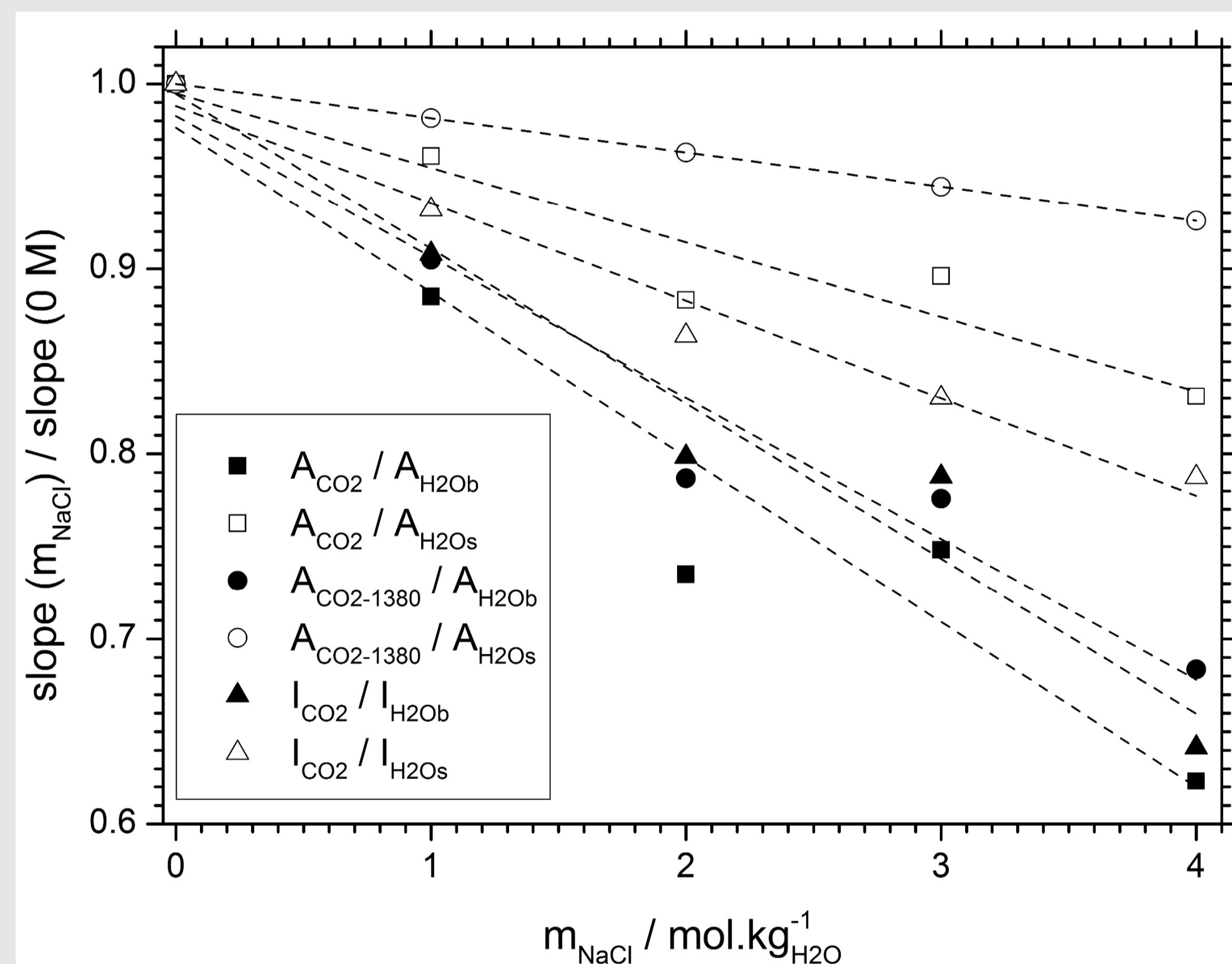

Different peak ratios to CO₂ solubility vs. salinity

Effect of salinity & Raman peak ratios

- Various peak area and peak intensity ratios are calculated vs. CO₂ solubility and salinity.
- All the ratios are **linearly correlated** to CO₂ solubility
- Sensibility to salinity varies between the different peak ratios: the less sensitive is $A_{CO_2-1380}/A_{H_2O_s}$; the most sensitive is $A_{CO_2}/A_{H_2O_b}$.

Effect of temperature

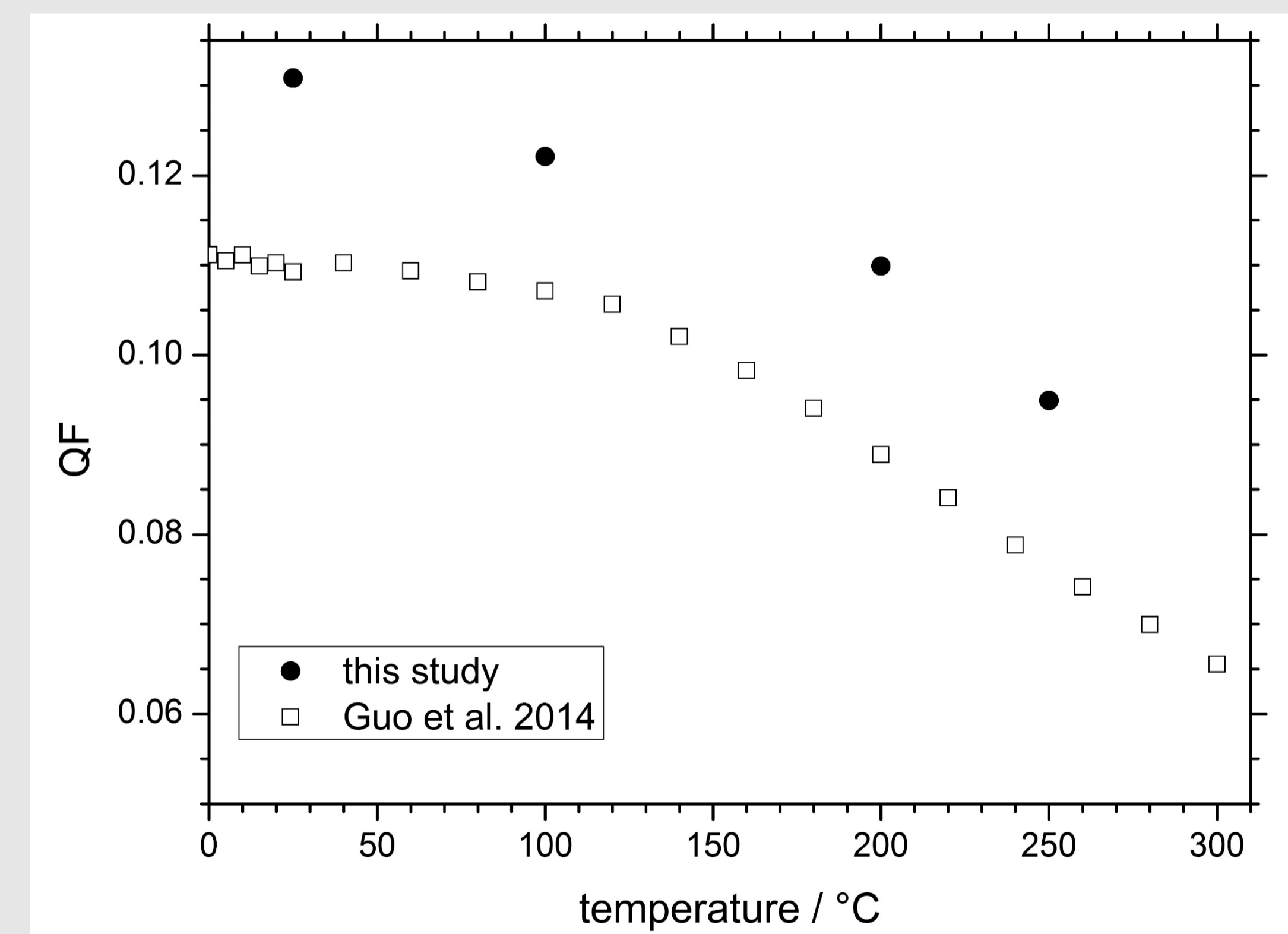

QF (= $(I_{CO_2}/I_{H_2O_s})/s_{CO_2}$) as a function of temperature in pure water

Effect of temperature

- The peak intensity ratio $I_{CO_2}/I_{H_2O_s}$ is the **only ratio linearly correlated to solubility** vs. temperature in pure water.
- The correlation **depends on temperature**. The present results are coherent with the previous data of Guo et al. (2014).

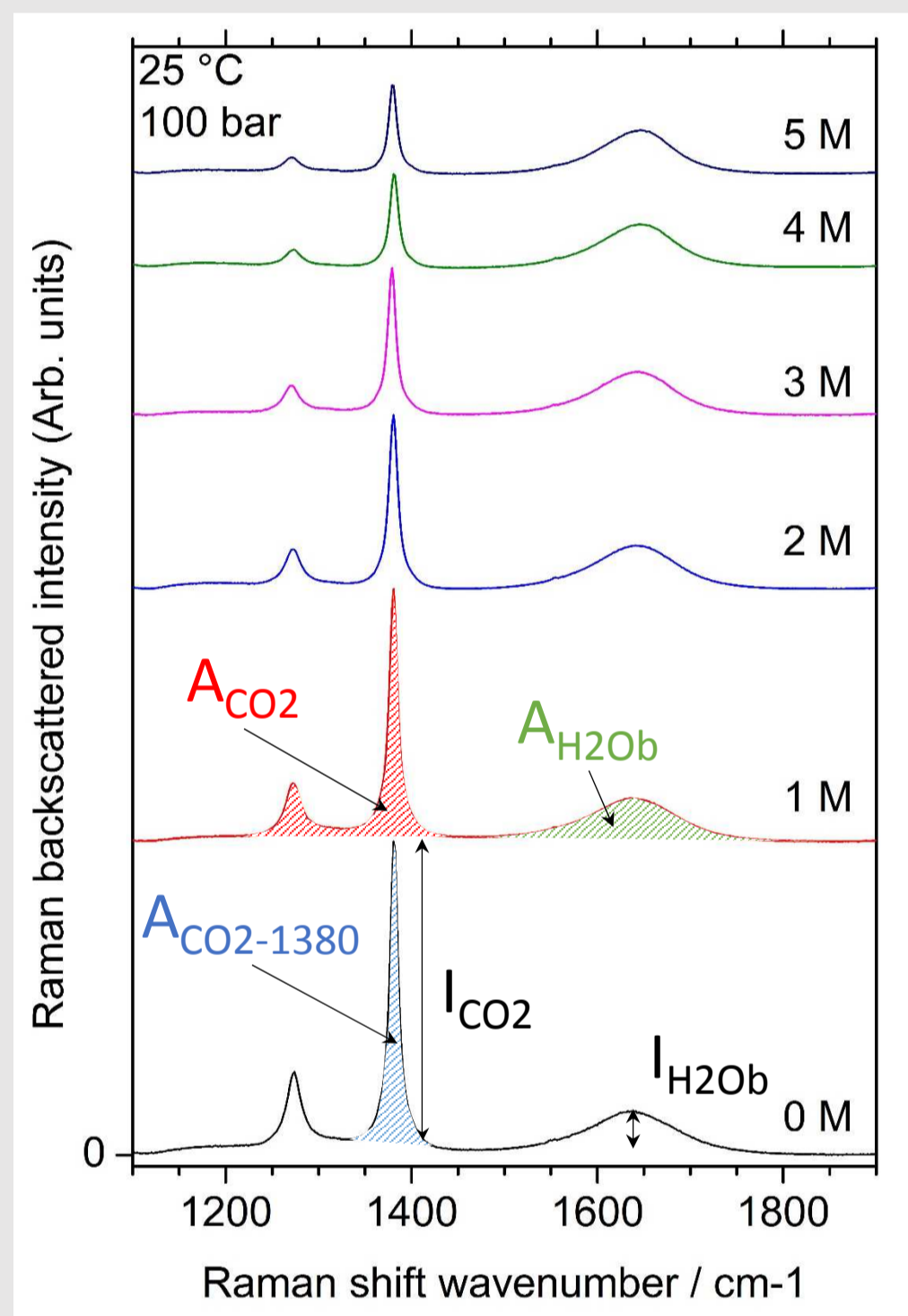

Dissolved CO₂ and bending vibration of H₂O

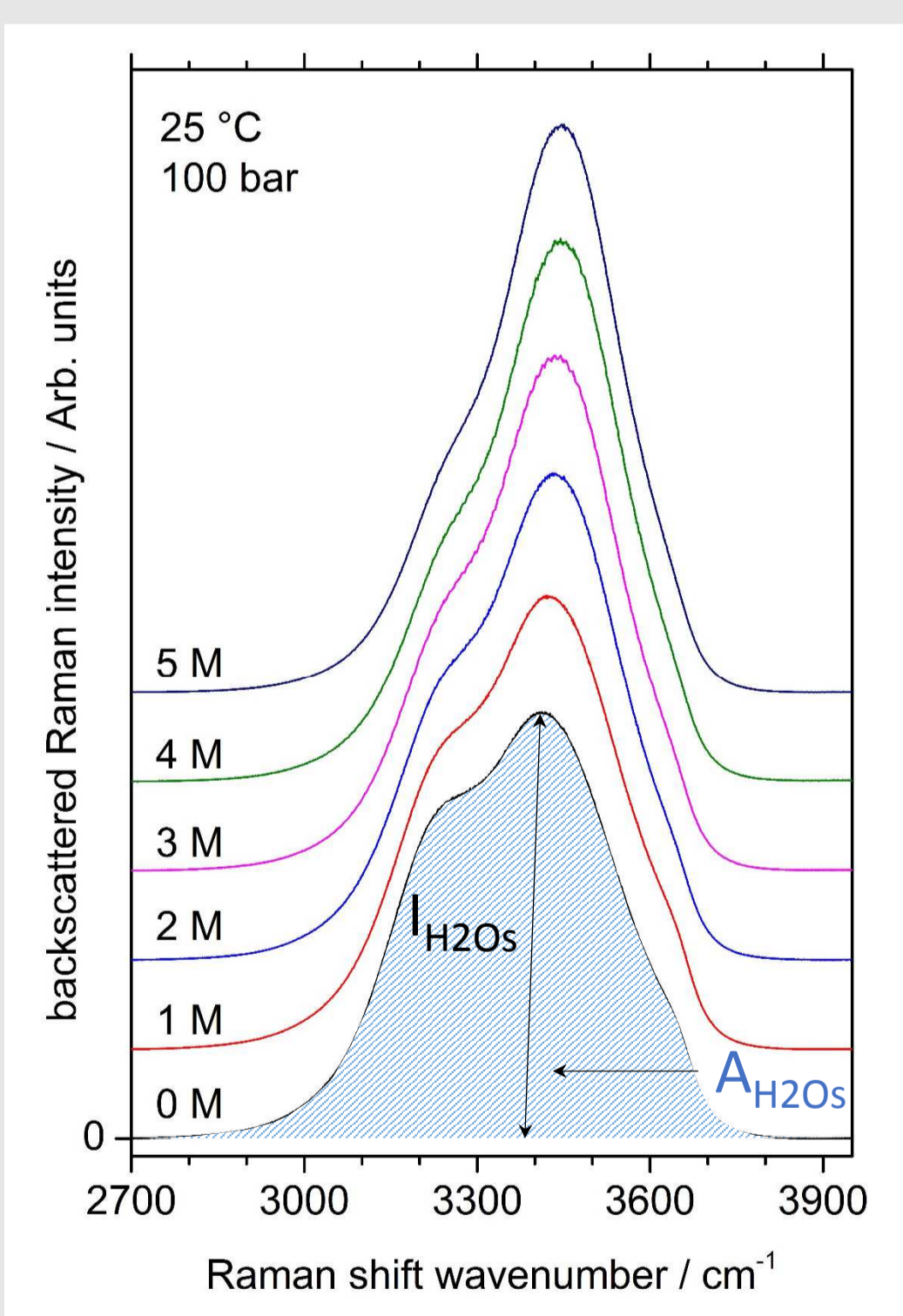

Stretching vibration of H₂O vs. [NaCl]

CONCLUSION

The **HPOC** setup is used to determine CO₂ solubility in saline water at 25 °C in the range 0-4 M NaCl, and in pure water as a function of temperature in the range 25 °C-250 °C. It makes possible **fast and reproducible measurements**, in a large range of pressure, temperature and salinity. The **linearity of the response as a function of salinity**, whatever which ratio is calculated (intensity or area, to the bending or stretching vibration band of water), confirms the validity of the equation of state of Duan and Sun (2003) in this range of experiment (25 °C, 0-4 M NaCl).