



HAL
open science

Software architectures to integrate workflow engines in science gateways

Tristan Glatard, Marc-Etienne Rousseau, Sorina Camarasu-Pop, Reza Adalat, Natacha Beck, Samir Das, Rafael Ferreira da Silva, Najmeh Khalili-Mahani, Vladimir Korkhov, Pierre-Olivier Quirion, et al.

► To cite this version:

Tristan Glatard, Marc-Etienne Rousseau, Sorina Camarasu-Pop, Reza Adalat, Natacha Beck, et al.. Software architectures to integrate workflow engines in science gateways. *Future Generation Computer Systems*, 2017, 75, pp.239-255. 10.1016/j.future.2017.01.005 . hal-01572420

HAL Id: hal-01572420

<https://hal.science/hal-01572420>

Submitted on 7 Aug 2017

HAL is a multi-disciplinary open access archive for the deposit and dissemination of scientific research documents, whether they are published or not. The documents may come from teaching and research institutions in France or abroad, or from public or private research centers.

L'archive ouverte pluridisciplinaire **HAL**, est destinée au dépôt et à la diffusion de documents scientifiques de niveau recherche, publiés ou non, émanant des établissements d'enseignement et de recherche français ou étrangers, des laboratoires publics ou privés.



Software architectures to integrate workflow engines in science gateways



Tristan Glatard^{a,b,c,*}, Marc-Étienne Rousseau^b, Sorina Camarasu-Pop^c, Reza Adalat^b, Natacha Beck^b, Samir Das^b, Rafael Ferreira da Silva^e, Najmeh Khalili-Mahani^b, Vladimir Korkhov^g, Pierre-Olivier Quirion^d, Pierre Rioux^b, Sílvia D. Olabariaga^f, Pierre Bellec^d, Alan C. Evans^b

^a Department of Computer Science and Software Engineering, Concordia University, Montreal, Canada

^b McGill Centre for Integrative Neuroscience, Montreal Neurological Institute, McGill University, Canada

^c University of Lyon, CNRS, INSERM, CREATIS, Villeurbanne, France

^d Centre de Recherche de l'Institut de Gériatrie de Montréal CRIUGM, Montréal, QC, Canada

^e University of Southern California, Information Sciences Institute, Marina del Rey, CA, USA

^f Department of Clinical Epidemiology, Biostatistics and Bioinformatics, Academic Medical Center, University of Amsterdam, Netherlands

^g St. Petersburg State University, Russia

HIGHLIGHTS

- We study 6 software architectures to integrate workflow engines in science gateways.
- We describe these architectures in a consistent framework.
- We assess their complexity, robustness, extensibility, scalability and functionality.
- Results provide insights for science gateway architects and developers.

ARTICLE INFO

Article history:

Received 16 May 2016

Received in revised form

17 October 2016

Accepted 7 January 2017

Available online 14 January 2017

Keywords:

Workflow engines

Science gateways

Software architectures

ABSTRACT

Science gateways often rely on workflow engines to execute applications on distributed infrastructures. We investigate six software architectures commonly used to integrate workflow engines into science gateways. In *tight integration*, the workflow engine shares software components with the science gateway. In *service invocation*, the engine is isolated and invoked through a specific software interface. In *task encapsulation*, the engine is wrapped as a computing task executed on the infrastructure. In the *pool model*, the engine is bundled in an agent that connects to a central pool to fetch and execute workflows. In *nested workflows*, the engine is integrated as a child process of another engine. In *workflow conversion*, the engine is integrated through workflow language conversion. We describe and evaluate these architectures with metrics for assessment of integration complexity, robustness, extensibility, scalability and functionality. Tight integration and task encapsulation are the easiest to integrate and the most robust. Extensibility is equivalent in most architectures. The pool model is the most scalable one and meta-workflows are only available in nested workflows and workflow conversion. These results provide insights for science gateway architects and developers.

© 2017 The Author(s). Published by Elsevier B.V.
This is an open access article under the CC BY license
(<http://creativecommons.org/licenses/by/4.0/>).

1. Introduction

Several software architectures can be adopted to integrate workflow engines in the ecosystem of tools and services offered by science gateways, with important consequences for the development effort required and resulting system. This paper describes, illustrates and compares such architectures, based on system-independent representations of their main components and inter-

* Correspondence to: Concordia University, Faculty of Engineering and Computer Science, Department of Computer Science and Software Engineering, 1455 De Maisonneuve Blvd. W., EV 3.139, Montreal, Quebec, Canada H3G 1M8.

E-mail address: tristan.glatard@concordia.ca (T. Glatard).

actions. It is informed by our experience in the development and sustained operation of the CBRAIN [1], NSG [2,3] and VIP [4] science gateways during the past 7 years, as well as by lessons learned from several science gateway and workflow projects such as SHIWA¹ and ER-flow.²

This analysis is intended for experts of science gateway and workflow engine design. It is an abstraction effort to identify and evaluate the fundamental architectural patterns that are encountered while integrating workflow engines and science gateways. In real systems, such patterns sometimes coexist due to the historical and technical context of software projects.

The remainder of this section provides background information and definitions of workflow engines, science gateways and infrastructures. In Section 2, we describe six architectures within a consistent framework that underlines the functional interactions between their main software components. We illustrate these architectures on real systems in Section 3. In Section 4, we introduce metrics that measure integration complexity, robustness, extensibility, scalability and functionality. The metrics are specifically designed to measure the ability of the architectures to address workflow-related issues commonly encountered in science gateways. We evaluate the architectures individually in Section 5, and we compare and discuss them in Section 6. Finally, in Section 7, we illustrate how our evaluation framework can be used to help design new systems. Related work is presented in Section 8.

1.1. Workflow engines

In the last decade, the e-Science community has developed workflow systems to help application developers access distributed infrastructures such as clusters, grids, clouds and web services. These efforts resulted in tools among which Askalon [5], Hyperflow [6], MOTEUR [7], Pegasus [8,9], Swift [10], Taverna [11], Triana [12], VisTrails [13], WS-PGRADE [14] and WS-VLAM [15]. Such workflow engines usually describe applications using a high-level language with specific data and control flow constructs, parallelization operators, visual edition tools, links with domain-specific application repositories, provenance recording and other features. An overview of workflow system capabilities is available in [16].

At the same time, toolboxes have been emerging in various scientific domains to facilitate the assembly of software components in consistent “pipelines”. In neuroimaging, our primary domain of interest, tools such as Nipype (Neuroimaging in Python, Pipelines and Interfaces [17]), PSOM (Pipeline System for Octave and Matlab [18]), PMP (Poor Man’s Pipeline [19]), RPPL [20], SPM (Statistical Parametric Mapping [21]) and FSL (FMRIB Software Library [22]) provide abstractions and functions to handle the data and computing flow between processes implemented in a variety of programming languages. Such tools were interfaced to computing infrastructures, in particular clusters, to execute tasks at a high throughput. Some of these tools also support advanced features such as provenance tracking or redundancy detection across analyses to avoid re-computation. A wide array of workflows have been implemented using these pipeline systems and are now shared across neuroimaging groups world-wide, which represents a tremendous opportunity for science gateways to leverage. Domain-specific engines nicely complement e-Science systems that are more oriented towards the exploitation of distributed computing infrastructures, in particular grids and clouds.

In this paper, a *workflow engine* (also abbreviated *engine*) is a piece of software that coordinates and submits interdependent

computing *tasks* to an *infrastructure* (local server, cluster, grid or cloud) based on a workflow description (a.k.a *workflow*), using input data that may consist of files, database entries or simple parameter values. Although simplistic, this definition covers both e-Science workflow engines and domain-specific pipeline systems. Some workflow engines, usually from the e-Science community, may transfer data across the infrastructure, and others, usually domain-specific ones, may leave this role to external processes. Workflows may be expressed in any language, including high-level XML or JSON dialects such as Scufi or Hyperflow, and low-level scripting languages such as Bash.

1.2. Science gateways

Science gateways are used to share resources within a community and to provide increased performance and capacity through facilitated access to storage and computing power. They are often accessible through a web interface that helps users manage access rights, data transfers, task execution, and authentication on multiple computing and storage locations. Workflow engines are part of this ecosystem as core components to implement and execute applications.

Various science gateways have been developed, including frameworks such as Apache Airavata [23], the Catania Science Gateway Framework [24] and WS-PGRADE/gUSE [14]. Numerous science gateways were built using such frameworks [25,24] or as standalone systems [1,4]. Most of these systems include one or several workflow engines.

Integration between workflow engines and science gateways varies across systems. Some science gateways are tailored to a particular engine, while others are more general and host applications executed by different types of engines.

Extensibility is an important property of the integration. New workflows are added frequently, different types and versions of workflow engines may be integrated over time, and different kinds of infrastructure can be targeted.

Scalability is also a crucial concern for such multi-user, high-throughput systems. For this purpose, science gateways may balance the load among different instances of the same engine, start new engines elastically using auto-scaling techniques such as the ones reviewed in [26], and use advanced task scheduling policies on the infrastructure to improve performance, fault-tolerance and fairness among users.

Robustness is highly desirable as well since it is key to a good user experience. Simple architectures facilitate the implementation effort towards robust interactions which, in turn, have a positive impact on characteristics such as gateway predictability, transparency, reliability, traceability and reproducibility.

Other specific features may also be available, for instance data visualization and quality control, workflow edition, debugging instruments, or social tools among users.

1.3. Infrastructure

An infrastructure consists of the computing and storage resources involved in workflow execution, as well as the software services used to access these resources. The infrastructure can be composed of computing or file servers, databases, clusters, grids or clouds. Some workflow engines and science gateways may require specific characteristics, such as the presence of a shared file system between the computing nodes, the availability of a global task meta-scheduler, or the presence of a file catalog. In the analysis presented hereafter, such specific requirements are not discussed. Instead, we consider the infrastructure as an abstract system that can execute tasks and store data regardless of the enabling mechanisms.

¹ <http://www.shiwa-workflow.eu>.

² <http://www.erflow.eu>.

Table 1
Classification of science gateways based on the architecture used to integrate workflow engines.

Architecture	Systems
Tight	Gateways based on the Catania Science Gateway Framework [24], Distributed application runtime environment (DARE [27]), LONI Pipeline Environment [28]
Service	Gateways based on Apache Airvata [23], HubZero with Pegasus [29], System in [30], Vine Toolkit [31], Virtual Imaging Platform [4], Gateways based on the WS-PGRADE/gUSE framework [14], GridSFEA [32]
Task Pool	CBRAIN and PSOM [33], CBRAIN and FSL SHIWA pool [34]
Nested Conversion	SHIWA Simulation Platform (Coarse-Grained Interoperability [35]), HubZero with Pegasus (via hierarchical workflows) [9], Tavaxy [36]. SHIWA Simulation Platform (Fine-Grained Interoperability) [37], Tavaxy [36], system in [38].

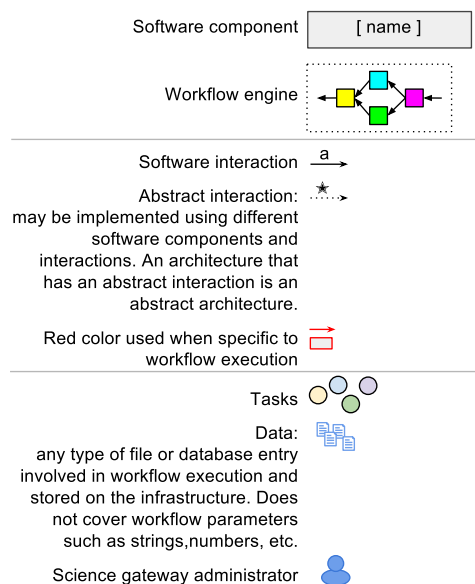

Fig. 1. Graphical notations.

2. Architectures

Architectures to integrate workflow engines in science gateways are presented in Fig. 2 using the graphical notations defined in Fig. 1. Software components are defined at a granularity such that two components may potentially be operated by different teams on different hardware systems. For instance, the science gateway and infrastructure are usually distinct components. In real systems, software components may exist at a finer granularity, to implement functions such as authentication, data persistence or logging. Such fine-grained components are not covered by our analysis since we focus on the interactions between the science gateway, the infrastructure and the workflow engine. Table 1 summarizes the classification of a few systems by architecture.

2.1. Interactions

The interactions involved in the architectures are described below and labeled from a to g as in Fig. 2.

(a) Workflow integration: consists in adding a new workflow to the system so that users can execute it. It is triggered by an administrator of the science gateway and it results in an interface, for instance a web form, where users can enter the parameters of the workflow to be executed. The interaction has two steps: (a_1) the programs used in the workflow are installed on the infrastructure or prepared for on-the-fly deployment, which may require specific privileges; (a_2) the workflow is configured in the science gateway so that it becomes available to users. Note that integrating a workflow is not the same process as integrating a workflow engine.

- (b) Task control: operations to manage tasks on the infrastructure, including authentication, submission, monitoring, termination, deletion, etc. Controlling tasks requires dealing with the heterogeneous batch managers and meta-schedulers that might be available on the infrastructure. When the infrastructure is a grid or a cloud, control may be achieved for instance using libraries that implement standards such as SAGA (Simple API for Grid Applications [39]), DRMAA (Distributed Resource Management Application API [40]), or OCCI (Open Cloud Computing Interface [41]).
- (c) Data control: operations to manage data on the infrastructure, such as upload, download, deletion, browsing, replication, caching, etc. Data movements can be triggered by the science gateway (c_1), e.g., to upload input data or download processed data. They can also be performed by the workflow engine (c_2), to transfer workflow data (inputs, outputs, or intermediate results) across the infrastructure so that tasks can use them. The infrastructure might offer various data storage backends with heterogeneous interfaces. Tools and services such as JSAGA [42] or Data Avenue [43] can be used to homogenize these interfaces.
- (d) Workflow control: operations to control workflow execution in an engine, including workflow submission, monitoring, termination, etc. Workflow control can be coarse-grained (black box) or fine-grained (white box). In a coarse-grained model, the various tasks created by a workflow execution are masked and the user only has a global view of the workflow execution. In a fine-grained model, user is exposed to the workflow topology, i.e., to the outputs of the individual tasks, their statuses, dependencies and so on.
- (e) Sub-task control: operations used by tasks to submit sub-tasks on the infrastructure, including: submission, monitoring, termination, deletion, etc. Sub-task control is similar to interaction b, except that information about the parent of a sub-task is usually available and used for additional control. For instance, the parent task may wait for all its sub-tasks to complete before finishing, and conversely all the sub-tasks may be terminated if the parent task is killed.
- (f) Pool-agent: specific to the pool architecture. This is an interaction used when agents retrieve work from a central pool. It covers agent registration and de-registration to the pool, protocols to send work from the pool to the agent, mechanisms to update work status, and so on. A similar type of interaction is used in pilot-job systems [44] and other agent-based computing models.
- (g) Workflow conversion: translation from one workflow language into another. This interaction may not be available or possible for every workflow language. It has been developed mostly for translation between well-structured and relatively simple workflow languages such as GWorkflowDL and ScufI [45], and for translation among the 5 workflow systems in the SHIWA project: Askalon, MOTEUR, Taverna, Triana and WS-PGRADE.

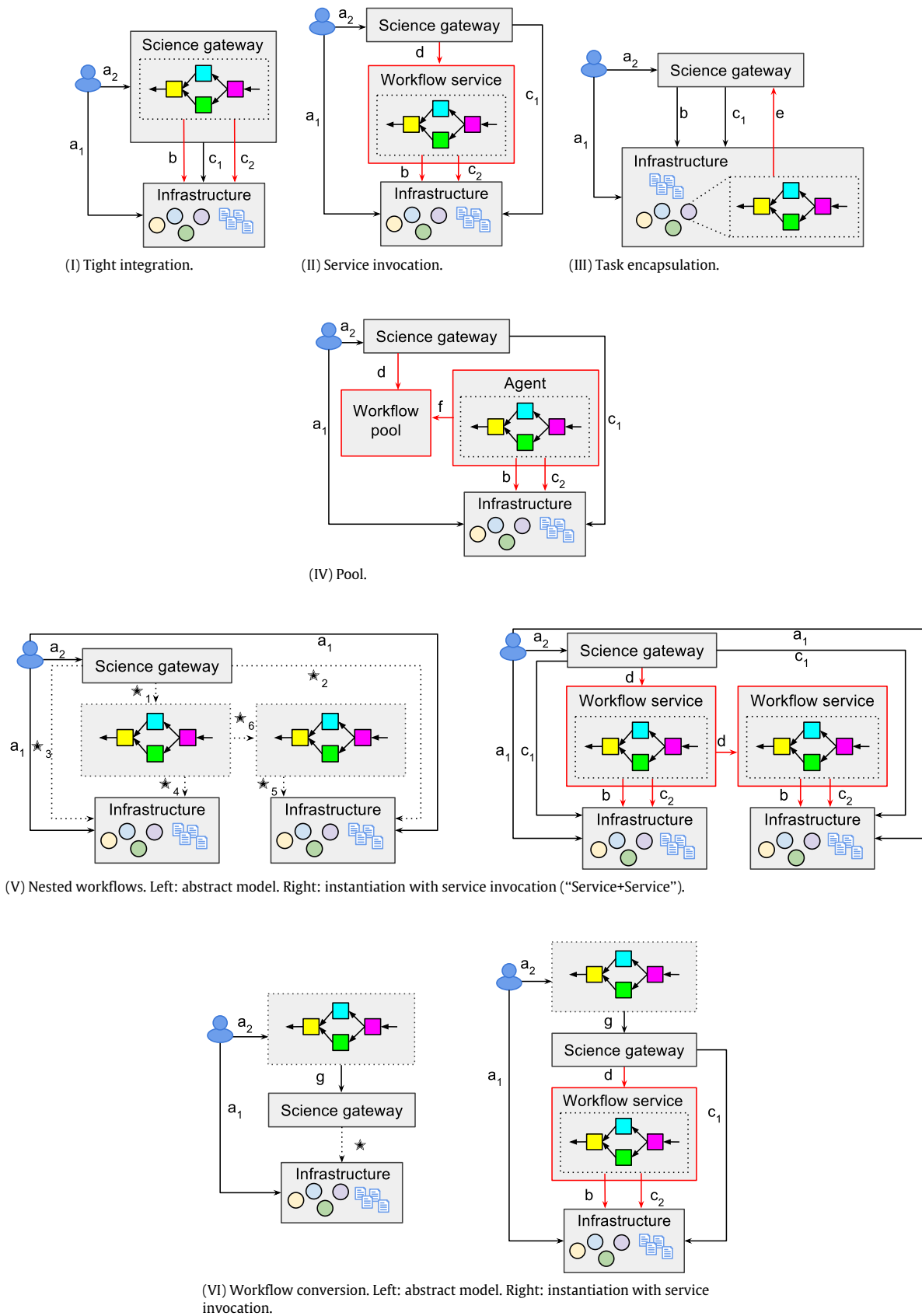

Fig. 2. Architectures. (For interpretation of the references to color in this figure legend, the reader is referred to the web version of this article.)

2.2. Tight integration

See Fig. 2(I). The workflow engine is tightly integrated with the science gateway, which means that it is deployed on the same machine and potentially shares code, libraries and other software components with the science gateway. For instance, the workflow engine might be a portlet in a Liferay portal or a model in a Ruby on Rails application.³ The workflow engine and the science gateway usually share a database where applications, users and other resources are stored. In this model, task and data control are both initiated from the science gateway. Interactions b and c_2 are initiated from the workflow engine, while c_1 comes from other parts of the science gateway, for instance a data management interface. As in any other model, the installation of new workflows in the science gateway (a_2) and infrastructure (a_1) is done by an administrator, for security reasons. Tight integration is the model adopted in the Catania Science Gateway Framework [24] (see specific documentation on workflows⁴), in the Distributed application runtime environment (DARE) [27], in Galaxy [46], and in the LONI Pipeline Environment [28]. Note that tightly integrated architectures may provide advanced workflow edition features which are not covered by our analysis.

2.3. Service invocation

See Fig. 2(II). The workflow engine is available externally to the science gateway, as a service. The science gateway controls the service through a specific interaction (d) that might be implemented as a web-service call (e.g., RESTful or SOAP), as a command-line or as any other method that offers a well-defined interface to the workflow engine. The workflow engine might be invoked either as a black box that completely masks the infrastructure and tasks, or as a white box that allows for some interaction with them. The workflow engine is responsible for controlling the tasks on the infrastructure (b) and for performing the required data transfers to execute them (c_2). User data is usually managed through the science gateway (c_1), although in some variations of the architecture (not represented in Fig. 2) it might as well be delivered by the workflow engine directly to the user.

This architecture is largely adopted in systems such as the Apache Airvata framework [23], GridSFEA [32], Vine Toolkit [31], Virtual Imaging Platform [4], the systems in [30,3] and the WS-PGRADE/gUSE framework [14]. The integration between the HubZero science gateway and the Pegasus workflow engine performed in [29] also uses a service architecture, where the d interaction is implemented as a set of calls to Pegasus' command-line tools (e.g., `pegasus-status`, `pegasus-plan`, etc.).

2.4. Task encapsulation

See Fig. 2(III). The workflow engine is wrapped in a particular task that can submit sub-tasks to the science gateway through interaction e . The workflow engine keeps track of the dependencies between the sub-tasks, but their execution is delegated to the science gateway that executes them on the infrastructure through interaction b . Although the science gateway has no global vision of

the workflow, it submits the sub-tasks to the infrastructure and completely controls them. For instance, it may cancel them when the workflow is canceled. The science gateway may also implement mechanisms to facilitate the handling of task dependencies, for instance lists of tasks that must be completed before a particular task can be executed.

The science gateway also transfers both user and workflow data across the infrastructure, through interaction c_1 .

2.5. Pool model

See Fig. 2(IV). Workflows are submitted by the science gateway to a central pool through interaction d . Agents connect to the pool asynchronously to retrieve and execute workflows through interaction f . Agents may be started according to various policies, for instance to ensure load balancing. Workflow engine controls tasks and data on the infrastructure through interactions b and c_2 , science gateway transfers user data through interaction c_1 , and administrator installs workflows through interaction a_1 and a_2 .

2.6. Nested workflows

See Fig. 2(V). In nested workflows (Fig. 2(V)-Left), a workflow engine is integrated as a *child* process of a *parent* workflow engine. Parent and child engines might use different languages and might run on different infrastructures. A parent workflow is also a meta-workflow. The science gateway communicates with the parent engine through abstract interaction $*_1$. The science gateway also communicates with the infrastructure to transfer user data through abstract interactions $*_2$ and $*_3$. Both workflow engines communicate with the infrastructure through abstract interactions $*_4$ and $*_5$. The parent engine communicates with the child engine through abstract interaction $*_6$. Administrator installs workflows through interactions a_1 and a_2 .

Nested workflows are abstract architectural patterns that can be instantiated in the various architectures described previously. We focus on instantiation with the service invocation model (Fig. 2(V)-Right) as this is the most used architecture. We call this instantiation “Service+Service” since both engines are integrated through service invocation. We assume that the parent and child workflow engines are distinct pieces of software that require different workflow services invoked by distinct d interactions. If this is not the case, then workflow services can be collapsed into a single one with a d interaction with itself. An example of such interaction is the use of hierarchical workflows in Pegasus [9]. Workflow engines communicate with infrastructures using b and c_2 . Science gateway transfers user data to infrastructures using c_1 .

Nested workflows have long been available in workflow engines, for instance in the Taverna workbench [11]. They are also used implicitly in several platforms where workflow engines are wrapped in workflow tasks as any other command-line tool. Nested workflows were notably used by the SHIWA Science Gateway to implement so-called Coarse-Grained workflow interoperability [35], i.e., to integrate various workflow engines in a consistent platform.

2.7. Workflow conversion

See Fig. 2(VI). This is an abstract model instantiated with the service invocation architecture for consistency. Workflow conversion is presented here as a pattern to integrate workflow engines in a science gateway, through workflow format conversion from a native format to the science gateway format. Workflow conversion is usually an offline process that is not involved in workflow execution. A few systems have implemented workflow conversion. In the SHIWA Simulation Platform, it is implemented through

³ Note that the particular case of portlets can be a bit ambiguous: when portlets are deployed remotely, using protocols such as Web Services for Remote Portlets (WSRP), they become independent software components according to our definition because they could be operated by different teams on different hardware systems. In this case, the system should be classified in the service invocation architecture since the portlets actually become Web Services. The same comment holds for remote object invocation.

⁴ <https://frama.link/jfzgaEbj>.

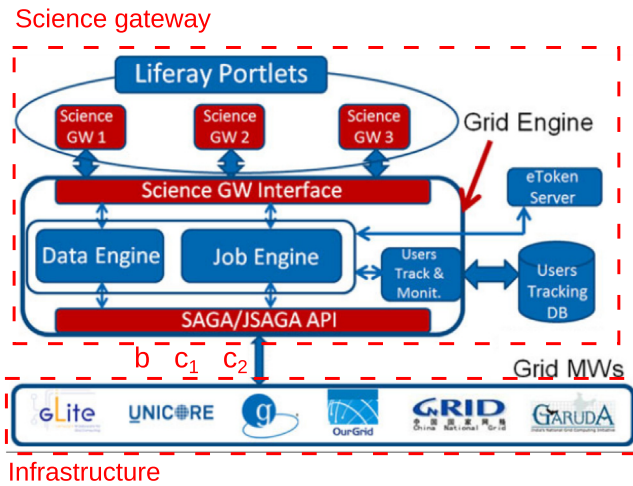

Fig. 3. Architecture of the Catania Science Gateway Framework (tight integration). Source: Figure adapted from [24] with permission of the first author.

the IWIR language, which provides a common language for portability across grid workflow systems [37] and allows conversion among n workflow languages using $2n$ interactions instead of n^2 . Tavaxy [36] enables the import, merging and execution of Taverna [11] and Galaxy [46] workflows; when some workflow parts cannot be imported, workflows are run by Tavaxy as nested workflows using their native engine. The work in [38] describes workflow conversion from KNIME [47] to WS-PGRADE/gUSE and from Galaxy [46] to WS-PGRADE/gUSE.

3. Real systems

This section illustrates the architectural patterns on a few real systems, using the original architecture diagrams published by the system developers. To improve readability, we annotated

these diagrams with the interactions and components used in Fig. 2.

3.1. Tight integration

The architecture of the Catania Science Gateway Framework (CSGF) is shown in Fig. 3. In CSGF, workflows are integrated as Liferay portlets, i.e., as part of the science gateway when no specific protocol is used for remote invocation. A specific portlet called `mi-parallel-portlet` allows to create job collections, parametric jobs and split-and-merge types of workflows. The science gateway also includes a set of services to manage data and tasks (jobs) on a wide array of grid middleware systems through the SAGA API.

3.2. Service invocation

Fig. 4 shows the architecture of the Virtual Imaging Platform (VIP), where the MOTEUR workflow engine [7] is invoked through a service. The interactions in the VIP architecture map to the ones defined by our framework in a straightforward manner, except for interaction c_2 (management of workflow data) which, in VIP, is triggered by the workflow tasks instead of the workflow engine. This does not contradict the service invocation architecture since the tasks are generated by the workflow engine.

3.3. Task encapsulation

Task encapsulation is used in the CBRAIN gateway [1] to integrate the FSL toolkit [22] and the PSOM workflow engine [18]. The CBRAIN-FSL integration, shown in Fig. 5(I), allows leveraging FSL pipelines written in low-level workflow languages (Linux executables and scripts) that submit tasks uniformly through a specific tool called `fsl_sub`. The science gateway is actually split in two services, the CBRAIN portal and the CBRAIN execution server deployed on a head node of the infrastructure. The mapping

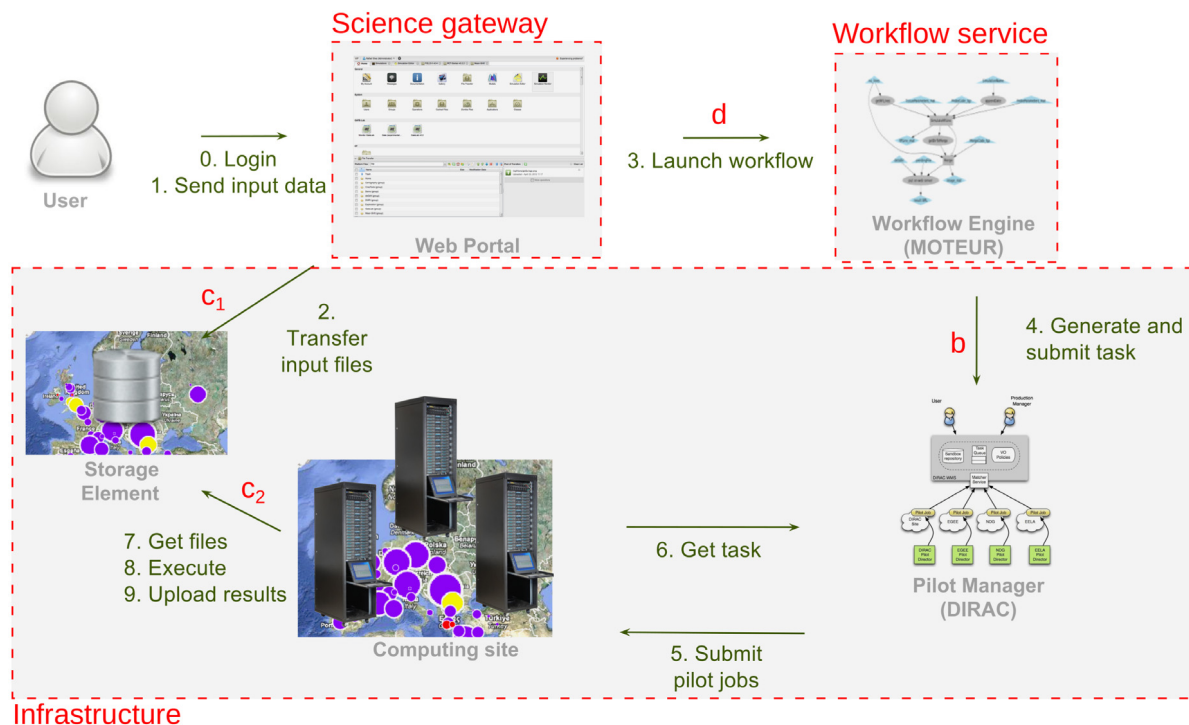

Fig. 4. Architecture of the Virtual Imaging Platform (service invocation). Step 3 corresponds to interaction d in Fig. 2(II), step 2 corresponds to interaction c_1 , step 4 maps to interaction b , and steps 7 and 9 map to c_2 (in VIP, workflow data transfers are performed by the tasks and embedded in their descriptions).

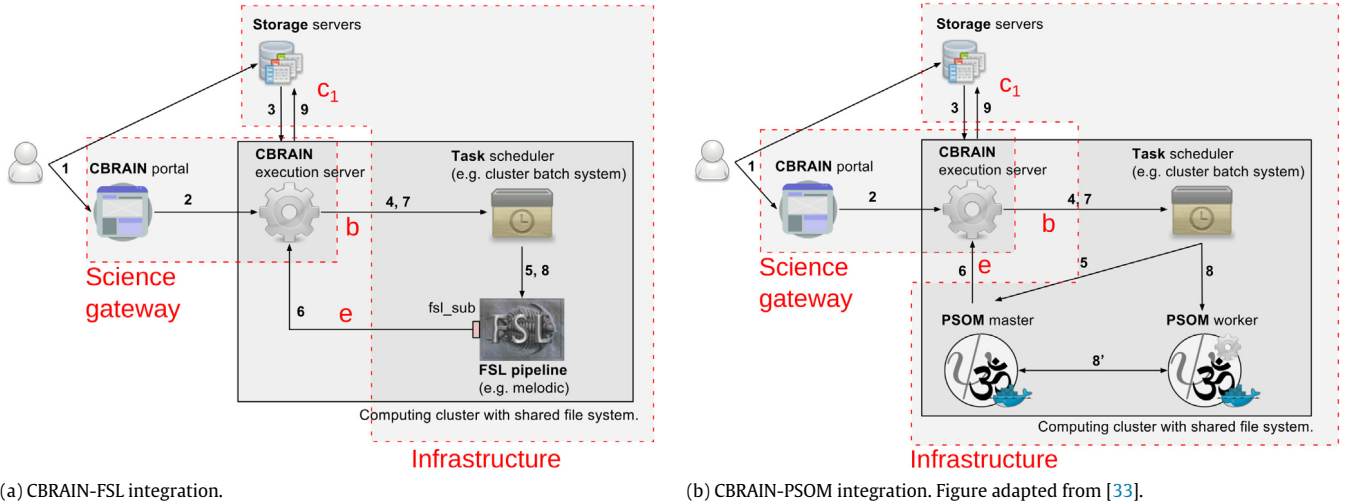

Fig. 5. CBRAIN architecture for workflow engine integration (task encapsulation). 1: User sends data and workflow execution request to storage server(s) and CBRAIN portal. 2: CBRAIN portal sends execution request to execution server on cluster. 3: Execution server transfers data from storage server(s). 4–5: Execution server starts workflow engine (FSL tool or PSOM master) via task scheduler. 6: Workflow engine submits sub-tasks to execution server (FSL tasks or PSOM agents). 7–8: Execution server starts sub-tasks through task scheduler (FSL sub-tasks or PSOM workers). FSL sub-tasks will run locally instead of being submitted again to CBRAIN through interaction 6. 8': (PSOM only) PSOM master and workers execute workflow. 9: Execution server transfers results to storage server(s). Interaction *b* in Fig. 2(III) is implemented by steps 4, 5, 7 and 8 (regular interactions with batch manager). Interaction *c*₁ is implemented by steps 3 and 9. Interaction *e* is implemented by step 6 (for FSL: through a modified version of the `fsl_sub` script available in <https://github.com/aces/cbrain-plugins-neuro>; for PSOM: through a specific development in PSOM).

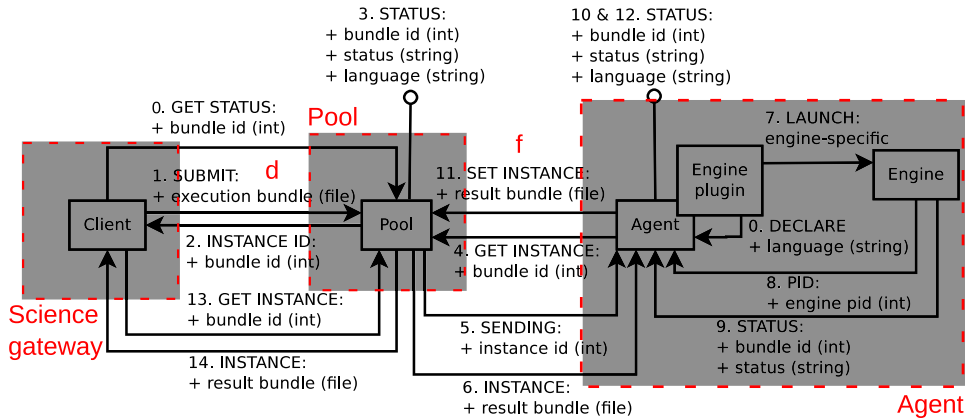

Fig. 6. Architecture of the SHIWA pool. Circle-terminated arrows indicate messages that are broadcast to all pool clients. Interaction *d* of Fig. 2(IV) is implemented by 3 different calls to the pool: workflow submission (1 & 2), workflow status retrieval (0 & 3), and workflow retrieval (13 & 14). Interaction *f* is implemented through 2 types of calls: workflow instance retrieval (4, 5 and 6), and workflow instance update (11 and 12). Workflow instance retrieval is used by the agents to fetch work from the pool. Workflow instance update is used by the agents to update workflow statuses. Calls 0, 7, 8 and 9 are used by workflow engine plugins to declare their supported language and to launch engines, and by workflow engines to report their status to the agent. These calls are specific to the SHIWA Pool implementation of the agent component and therefore have no corresponding representation in Fig. 2(IV). Source: Figure adapted from [34].

of interactions *b*, *c*₁ and *e* to the CBRAIN-FSL interactions is straightforward.

The CBRAIN-PSOM integration [33] is shown in Fig. 5(II). The PSOM workflow engine adopts a pilot-job architecture [44] where a master coordinates workflow execution by submitting workers and establishing direct communication channels with them. Note how this peculiar execution model is well supported by task encapsulation.

3.4. Pool model

The pool model was implemented in the SHIWA pool [34] diagrammed in Fig. 6, where agents can wrap different types of workflow engines to execute workflows expressed with different languages. The software components map directly to the ones in our architecture, except that the infrastructure is not represented.

The interactions described in the SHIWA pool are much finer-grained than in our model, but they can be grouped to match interactions *d* and *f*, as explained in the Figure caption.

3.5. Nested workflows with service invocation

Fig. 7 shows the architecture used in the SHIWA Simulation Platform for nested workflow execution with service invocation. The parent workflow engine is WS-PGRADE/gUSE, invoked as a service in the Science Gateway (interaction *d*). Ten different child engines can be used by nested workflows, invoked through the Submission service (interaction *d*). Each of these engines can submit tasks and transfer data to a distributed computing infrastructure (DCI interactions *b* and *c*₂). User data interactions (*c*₁) and interactions between the parent engine and the infrastructure (*b* and *c*₂) are not represented.

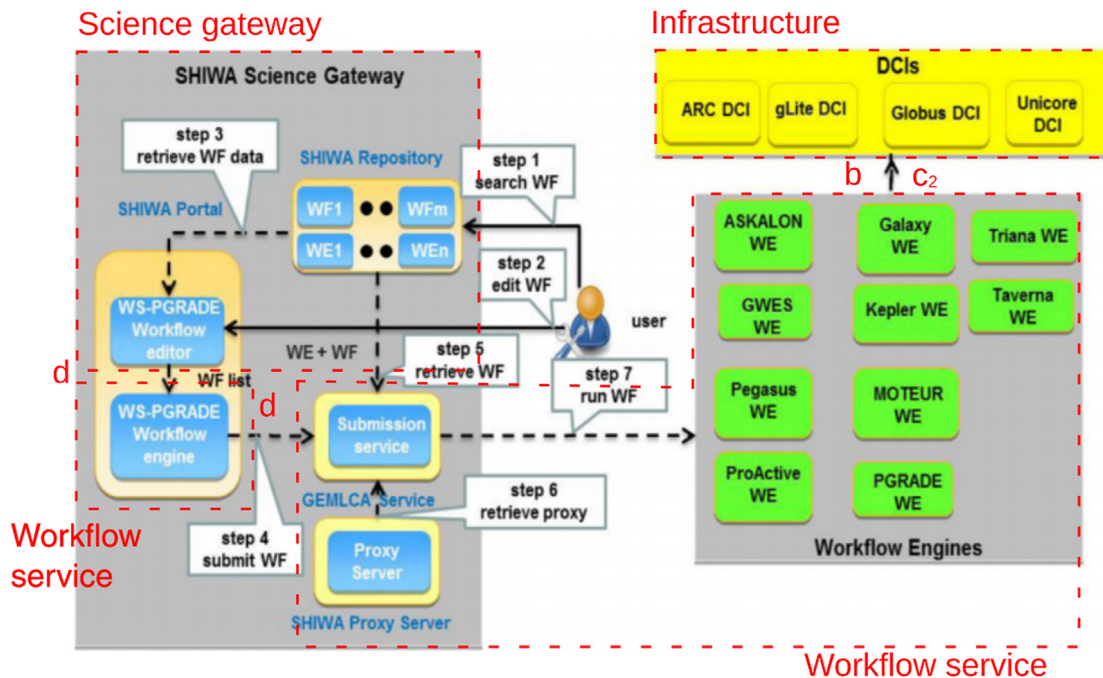

Fig. 7. Nested workflow execution through the SHIWA Science Gateway.
Source: Figure adapted from [35] with permission of the first author.

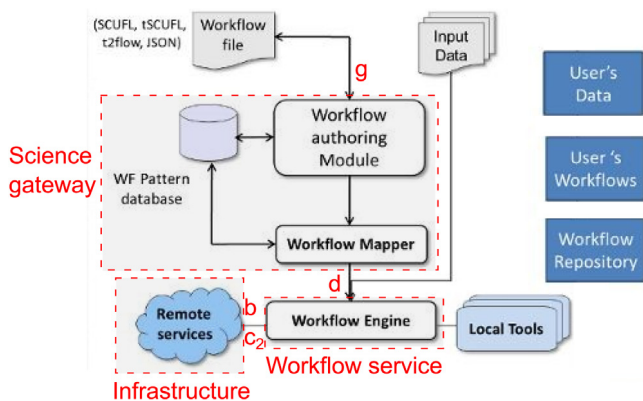

Fig. 8. Architecture of Tavaxy (workflow conversion).
Source: Figure adapted from [36] with permission of the first author.

3.6. Workflow conversion with service invocation

Fig. 8 shows the architecture of Tavaxy where workflows in various formats (tSCUFL, SCUFL, t2flow and JSON) can be imported. As detailed in [36], workflow conversion (interaction g) is implemented through an interactive authoring module where users can check and edit workflow imports, and a mapper module that performs some language substitutions. The workflow engine is a re-engineered version of the Galaxy engine that also includes some components of Taverna.

4. Evaluation metrics

The architectures are evaluated in Table 2 using five main criteria: integration complexity, robustness, extensibility, scalability and functionality. Criteria break down into specific metrics where lower value indicates better performance. Colors in Table 2 represent normalized scores (see caption). For each criterion, a global score is computed by summing up the individual scores for each metric. We ensure that the different metrics used to calculate the global

score for a criterion are comparable, so that they can be combined meaningfully.

The metrics defined hereafter aim at providing a framework to evaluate architectures independently from any particular system, regardless of any technical constraint such as the use of a specific programming language or the internal architecture of the science gateway. The goal is to abstract architectural discussions from the particular technical context of a real system. Some degree of system-specificity can be introduced in the evaluation by assigning weights to interactions and components through a public spreadsheet available at <https://frama.link/LrPRsCQp>.⁵ In particular, sheet “Components and interactions” in this spreadsheet contains the weight assigned to components and interactions, which can be used to produce new versions of Table 2 that fit the particular technical context of a real system. For instance, a high weight could be assigned to the science gateway if its internal architecture is such that it can hardly be extended in practice.

In addition, all the metrics in a criterion contribute equally to the global score used for the criterion. Column B of sheet “Metrics” of the public spreadsheet may be used to assign different weights to each metric to adjust the specific context of a study.

The remainder of this Section defines the metrics in each criterion.

4.1. Integration complexity

Integration complexity is measured through the number of software components and their interactions. It breaks down into the following 2 metrics:

- Total components (I_1): total number of components in the architecture.
- Total interactions (I_2): total number of interactions in the architecture.

⁵ The spreadsheet may need to be downloaded to be edited.

Table 2

Architecture evaluation. Lower values (brighter colors) indicate better performance. Cell color is set as follows: (1) on each row, metric values are normalized between 0 (best value) and 1 (worst value): $m' = \frac{m - m_{\min}}{m_{\max} - m_{\min}}$ where m is the metric value, m_{\min} and m_{\max} are the minimum and maximum values for all architectures; (2) the RGB hexadecimal color code of the cell is #99XX99, where $X = \text{round}(F - 6m')$ (round rounds a number to the nearest integer).

	Tight	Service	Task	Pool	Nested Service+Service	Conversion
Integration complexity						
Total components – I ₁	2	3	2	4	5	3
Total interactions – I ₂	5	6	5	7	11	7
Total (total software pieces)	7	9	7	11	16	10
Robustness						
Specific components – R ₁	0	1	0	2	2	1
Specific interactions – R ₂	2	3	1	4	6	3
Total (execution software pieces)	2	4	1	6	8	4
Extensibility						
New engine type – E ₁	3	3	2	3	4.5	1
New engine version – E ₂	1	0	1	0	0	1
New workflow – E ₃	2	2	2	2	2	3
New infrastructure – E ₄	4	4	3	4	6	4
Total (difficulty to extend)	10	9	8	9	12.5	9
Scalability						
Multiple engine instances – S ₁	2	1	0	0	1	1
Distributed engines – S ₂	1	1	1	1	0	1
Task scheduling – S ₃	0	0	1	0	1	0
Total (scalability issues)	3	2	2	1	2	2
Functionality						
Meta-workflow – F ₁	1	1	1	1	0	0
Fine-grained debugging – F ₂	0	1	1	1	1	1
Total (missing features)	1	2	2	2	1	1

One may wonder whether infrastructure should be counted in I₁, since it is usually an external entity that is not developed nor maintained by the groups who integrate workflow engines in science gateway. We support its inclusion here because integrating an infrastructure into the system usually requires some technical effort (e.g., account creation, software installation, APIs, etc.), therefore increasing complexity. The weights given to software components in I₁ and interactions in I₂ can be adjusted in the public spreadsheet to cover the technical peculiarities of a real system.

The two metrics I₁ and I₂ are summed to obtain a global score that measures the total number of software pieces affected by integration.

4.2. Robustness of workflow execution

Robustness of workflow execution measures the likelihood that the workflow execution fails due to errors in the components or in the interactions of the software architecture. Errors coming from the infrastructure (e.g., unavailable data or terminated tasks) or workflows (e.g., wrong user input or application errors) are not covered, since they do not stem directly from the software architecture. Robustness is measured here as a consequence of global complexity, since complex architectures tend to be more prone to failure, in particular in distributed systems where interactions between components involve wide-area network communications between machines that may be operated by different people. More precisely, robustness is determined by the number of software components and interactions represented in red in the architecture diagrams in Fig. 2, which are specific to workflow execution. Two metrics are used:

- Specific components (R₁): number of specific components involved in workflow executions. For instance, the workflow service is a specific component because its main objective is to execute workflows. On the contrary, the science gateway is *not* specific to workflow execution since it is used for a variety of other functions such as user authentication, data transfer, etc.

- Specific interactions (R₂): number of specific interactions involved in workflow executions. For instance, the pool–agent interaction (interaction *f*) is specific to workflow execution while data control (interaction *c*₁) is *not* because it is used by the science gateway to transfer user data regardless of a particular workflow execution.

R₁ and R₂ are summed to obtain the global score for this criterion, which measures the total number of software pieces that are specifically involved in the workflow execution. The weights given to software components in R₁ and interactions in R₂ can be adjusted in the public spreadsheet.

4.3. Extensibility

Extensibility measures the difficulty to replace or add elements to the architecture. It is determined by the number of interactions and components that need to be modified when a new element is added. Modification of a component is required when its code needs to be updated or recompiled (science gateway or workflow service), or when a new piece of software has to be installed (infrastructure only). Modification of an interaction is deemed necessary when the parameters involved in this interaction are modified. Extensibility breaks down into 4 metrics depending on the type of element (engine, workflow or infrastructure) that has to be added or replaced:

- New engine (E₁): number of interactions or components that need to be modified to integrate a new type of workflow engine in the architecture. Workflow engines belong to different types when they cannot be invoked using the same implementation of the interactions.
- Engine version upgrade (E₂): number of interactions or components modified to integrate a new version of a workflow engine in the architecture, assuming that another version of the same engine type is already available. Different versions of a workflow engine can be invoked using the same interaction implementation(s). When this is not the case, the different versions

are considered as different engine types. Components are not treated equally regarding engine version updates. Components whose only function is to host the workflow engine, i.e., workflow services and agents, are not counted in E_2 because updates in such components are assumed to be straightforward. On the contrary, modifications of components that have other functions than wrapping the engine, i.e., science gateway and infrastructure, are counted in E_2 because updates in these components require more effort, e.g., new release of the science gateway, gaining administrative privileges on the infrastructure, etc. In practice, $E_2 = 0$ when the workflow engine is wrapped in a service or in an agent, and $E_2 = 1$ when it is wrapped in another component.

- New workflow (E_3): number of interactions required to integrate a new workflow in the architecture. Adding a new workflow is a very common operation that does not require modifying software components or interactions, assuming that the engine type and version required to execute this workflow are already available. In most cases, adding a new workflow requires only interactions a_1 and a_2 , but g is required as well when workflow conversion is used.
- New infrastructure (E_4): number of interactions or components affected for the integration of a new type of infrastructure in the architecture. Adding a new infrastructure typically aims at providing more computing or storage power, enabling access to specific types of resources (e.g., GPUs, clouds), or enforcing execution policies (e.g., constrain data to remain in a particular network domain).

The four metrics are summed to obtain a global score that measures the difficulty to extend the architecture. The weights given to software components and interactions in E_{1-4} can be adjusted in the public spreadsheet. Note that some extensions may affect several metrics in practice. For instance, adding a new type of engine may help integrating new infrastructures when interactions b and c_2 are already present for the new engine and the infrastructure.

4.4. Scalability

Scalability corresponds to the ability of an architecture to cope with high workloads through the following mechanisms: starting multiple engine instances, distributing engines and task scheduling. This is measured by assessing the potential scalability difficulties due to (partial) absence of a given feature in the architecture. Three different features are identified:

- Multiple engine instances (S_1): measures the ability for a single gateway instance to use more than one engine instance simultaneously, *each workflow being executed by a single engine instance*. Workflow engines may require important amounts of resources when several workflows, or large workflows, are executed. At some point, it may be required for the science gateway to distribute the load among several engines. $S_1 = 0$ means that adding a new engine instance is inherently supported in the architecture. In this case, elastic engines can be implemented through some kind of auto-scaling mechanism to control the number of engine instances in the architecture. $S_1 = 1$ means that supporting multiple engine instances requires specific developments in the science gateway or workflow engine. $S_1 = 2$ means that new engine instances cannot be added.
- Distributed engines (S_2): measures the ability to distribute the execution of a single workflow among different engine instances. In our scope, this feature focuses on the capabilities of the architecture rather than those of the workflow engine. $S_2 = 0$ means that distributed engines are enabled by the architecture, and $S_2 = 1$ that they require specific developments in the workflow engine.

- Task scheduling (S_3): measures the complexity added by the architecture to implement task scheduling on the infrastructure. Task scheduling typically depends more on the implementation of specific algorithms in the science gateway, workflow engine and infrastructure than on the architecture used to integrate the workflow engine in the science gateway. Some architectures, however, complicate the task scheduling problem by introducing additional software layers or creating tasks with specific characteristics. $S_3 = 0$ means that the architecture does not add any additional complexity to the scheduling problem, and $S_3 = 1$ otherwise.

These three metrics are summed to obtain a global measure of the scalability potential of the architecture.

4.5. Functionality

Functionality includes:

- Meta-workflow (F_1): measures the ability to describe meta-workflows from existing workflows. Meta-workflows offer an additional level of flexibility to build workflows from reusable components. $F_1 = 0$ means that meta-workflows are intrinsically enabled by the architecture (i.e., they can be implemented using the components and interactions already in place), and $F_1 = 1$ means that they may be implemented with some development effort.
- Fine-grained debugging (F_2): availability of fine-grained debugging information about workflow tasks (white box workflow). We call “white box” workflow a workflow where detailed information about individual tasks is available, for instance task statuses, execution logs and resource consumption. On the contrary, a “black box” workflow only displays global information such as the workflow status and the logs of the workflow engine. Fine-grained information about workflow tasks is required to properly troubleshoot workflow executions. It helps workflow users (scientists) identify errors, it allows gateway administrators to troubleshoot executions, and it facilitates debugging by workflow developers. The availability and accuracy of fine-grained debugging information usually depends on the number of software layers between the science gateway and the workflow engine [48]. $F_2 = 0$ means that the information is directly accessible in the science gateway, $F_2 = 1$ means that it is obtained through one or more software interactions.

F_1 and F_2 are summed to obtain a total number of missing features in the architecture.

5. Architecture evaluation

The architectures described in Fig. 2 are evaluated hereafter with the proposed metrics.

5.1. Tight integration

Integration complexity. This architecture does not require any component in addition to the science gateway and infrastructure ($I_1 = 2$) and it involves 5 interactions: a_1 , a_2 , b , c_1 and c_2 ($I_2 = 5$).

Robustness. No component is specific to workflow execution ($R_1 = 0$), but interactions b and c_2 are ($R_2 = 2$).

Extensibility. Integrating a new type of workflow engine requires modifying the science gateway as well as interactions b and c_2 ($E_1 = 3$). Updating a workflow engine version requires modifications in the science gateway ($E_2 = 1$). Inserting a new workflow is done through interactions a_1 and a_2 ($E_3 = 2$). Adding a new infrastructure generates updates in interactions a_1 , b , c_1 and c_2 ($E_4 = 4$).

Scalability. Adding a new engine instance requires a new instance of the complete science gateway ($S_1 = 2$). Specific IT setups such as load-balancing between web server instances might be used to create new gateway instances, but they would not allow a single gateway instance to use multiple engine instances, which is the point here. Distributed engines are not available by default ($S_2 = 1$). The architecture does not add any particular complexity to the task scheduling problem since the workflow engine may implement any kind of scheduling policy ($S_3 = 0$).

Functionality. Supporting meta-workflows requires specific developments in the workflow engine or science gateway to allow workflows to execute other workflows ($F_1 = 1$). For instance, specific Java objects may be implemented in the science gateway framework to execute different types of workflows and link them together. The science gateway can retrieve fine-grained debugging information from the workflow engine directly ($F_2 = 0$).

5.2. Service invocation

Integration complexity. Service invocation requires a workflow service in addition to the science gateway and infrastructure ($I_1 = 3$). The architecture involves 6 interactions: a_1 , a_2 , b , c_1 , c_2 and d ($I_2 = 6$).

Robustness. The workflow service is a component specific to workflow execution ($R_1 = 1$). Workflow execution also involves 3 specific interactions: b , c_2 and d ($R_2 = 3$).

Extensibility. Adding a new type of workflow engine requires implementing the corresponding workflow service, modifying interaction d , and implementing interactions b and c_2 . However, when a new type of workflow engine is added, it is always possible to reuse either an existing available workflow service or interaction d (when a new workflow service has to be developed). Therefore, $E_1 = 3$. New engine versions can be added by updating the workflow service without modifying any interaction or component ($E_2 = 0$). Updating the engine version in a workflow service does not count in E_2 since the only goal of this component is to wrap the engine. New workflows are added in the science gateway or in the workflow engine through interactions a_1 and a_2 ($E_3 = 2$). Adding a new type of infrastructure requires updates in interactions a_1 , b , c_1 and c_2 ($E_4 = 4$).

Scalability. The service architecture in principle supports multiple engine instances through multiple workflow services. Adding a new engine instance, however, requires specific developments in the science gateway ($S_1 = 1$). Distributing the execution of a single workflow in multiple engines is usually not possible unless the workflow engine has specific abilities ($S_2 = 1$).

Functionality. Meta-workflows require specific developments in the workflow engine or science gateway to allow workflows to execute other workflows. ($F_{1=1}$). The science gateway needs to invoke interaction d to retrieve fine-grained debugging information from the workflow service ($F_{2=1}$).

5.3. Task encapsulation

Integration complexity. Task encapsulation requires only 2 components ($I_1 = 2$). It involves 5 interactions: a_1 , a_2 , b , c_1 and e ($I_2 = 5$).

Robustness. No component is specific to workflow execution ($R_1 = 0$), and only interaction e is necessary ($R_2 = 1$).

Extensibility. Integrating a new type of workflow engine requires developing interaction e and installing the engine on the infrastructure ($E_1 = 2$). Updating an engine version in the architecture shares the same mechanism as version updates of other tasks,

which requires an update on the infrastructure ($E_2 = 1$). New workflows are integrated by creating a new task in the science gateway through interactions a_1 and a_2 ($E_3 = 2$). Adding a new infrastructure requires updating interactions a_1 , b and c_1 in the science gateway ($E_4 = 3$).

Scalability. New engine instances are spawned and executed on the infrastructure as any other task upon user submission ($S_1 = 0$). This is a major interest of task encapsulation. Distributed engines are not supported by default ($S_2 = 1$). Task scheduling is slightly more complex than in the other approaches due to the special role of the task that executes the workflow engine ($S_3 = 1$). Indeed, the reliability of this task is critical since all the sub-tasks in the workflow depend on it and, depending on the recovery capabilities of the workflow engine, may need to be resubmitted if the workflow task fails. The workflow task is also longer than all its sub-tasks, which increases its chances of failure. In addition, task parameters, for instance estimated walltime, are more difficult to estimate for the workflow task than for the sub-tasks because workflows are by definition more complex than their sub-tasks: errors on sub-task parameter estimations accumulate in the workflow, and additional control constructs such as tests and loops may further increase the uncertainty. Such parameter estimation errors may generate issues such as selection of wrong batch queues on clusters or task termination due to exceeded quotas. Finally, the interdependencies between the workflow task and its sub-tasks may create deadlocks when there is contention. For instance, if only 1 computing resource is available for the science gateway and if the workflow task is running on it and submits sub-tasks, then the sub-tasks could only execute when the resource is available, which will never happen because the workflow task will not complete until the sub-tasks complete. This configuration can be generalized to an infrastructure with n resources where n workflows are submitted. In practice, however, the number of submitted workflows usually remains lower than the number of computing resources available on this infrastructure, which makes such deadlocks unlikely to happen.

Functionality. Task encapsulation does not enable meta-workflows by default ($F_{1=1}$). Fine-grained debugging information is obtained through interaction b ($F_{2=1}$).

5.4. Pool model

Integration complexity. The pool model requires a workflow pool and an agent in addition to the science gateway and infrastructure ($I_1 = 4$). It involves 7 interactions: a_1 , a_2 , b , c_1 , c_2 , d and f ($I_2 = 7$).

Robustness. The workflow pool and agent are specific to workflow execution ($R_1 = 2$). Interactions b , c_2 , d and f also are ($R_2 = 4$).

Extensibility. Adding a new engine type requires wrapping the engine into the agent and updating interactions b and c_2 ($E_1 = 3$). Updating the version of an engine is transparent ($E_2 = 0$) since it only requires updating the agent, which is a component dedicated to the engine. Integrating a new workflow is done through interactions a_1 and a_2 ($E_3 = 2$). Integrating a new infrastructure requires updates in interactions a_1 , b , c_1 and c_2 ($E_4 = 4$).

Scalability. By design, new engine instances only require new agents, which can be easily automated ($S_1 = 0$). Distributed engines are not available by default ($S_2 = 1$) and the architecture does not add any complexity to the task scheduling problem ($S_3 = 0$).

Functionality. Meta-workflows require specific developments in the workflow engine to enable workflow submission ($F_{1=1}$). Debugging information is accessed through interactions d and f ($F_{2=1}$).

5.5. Nested workflows with service invocation

Integration complexity. Setting up a nested workflow architecture with service invocation requires a science gateway, 2 workflow services and 2 infrastructures ($I_1 = 5$). The architecture involves 11 interactions ($I_2 = 11$): a_1 (twice), a_2 , b (twice), c_1 (twice), c_2 (twice) and d (twice).

Robustness. The two workflow services are specific to workflow execution ($R_1 = 2$). Interactions b (twice), c_2 (twice) and d (twice) also are necessary ($R_2 = 6$).

Extensibility. Adding a new type of *parent* engine requires implementing the corresponding service, implementing interactions b and c_2 in the parent engine, and implementing interaction d in the science gateway and in the parent service ($E_1 = 5$). Adding a new type of *child* engine only requires implementing the corresponding service, developing interactions b and c_2 in the child engine, and implementing interaction d in the parent service ($E_1 = 4$). We use $E_1 = 4.5$ in Table 2 to reflect both conditions. Adding a new version in the parent or child engine only requires modifying this engine ($E_2 = 0$). Adding a new workflow is done through interaction a_1 and a_2 ($E_3 = 2$). Adding a new infrastructure requires re-implementing interactions a_1 , b and c_2 twice, and interaction c_1 once so that it can be supported by both workflow engines ($E_4 = 6$).

Scalability. As in the service architecture, adding a new engine instance requires specific developments in the science gateway (instance of a parent engine), or in the parent engine (instance of a child engine) ($S_1 = 1$). Similarly, elastic engines are difficult to achieve. Distributed engines can be implemented through meta-workflows ($S_2 = 0$). Task scheduling is more complex than in other architectures though, due to the fact that workflow execution is split in different engines ($S_3 = 1$).

Functionality. Meta-workflows can be implemented, which is one of the main interest of this architecture ($F_{1=0}$). Note, however, that the complexity of the architecture increases with the number of engine types involved in meta-workflows: for instance, a meta-workflow with child workflows executed by 2 different types of engines would require an additional workflow service and the corresponding interactions. Debugging information is accessed through interaction d (invoked twice) ($F_{2=1}$).

5.6. Workflow conversion with service invocation

Integration complexity. Workflow conversion with service invocation requires the same components as for service invocation ($I_1 = 3$), and an additional g interaction ($I_1 = 7$).

Robustness. Since workflow conversion is not involved in the execution (it is an offline process), the scores are the same as for the service architecture ($R_1 = 1$, $R_2 = 3$).

Extensibility. Since adding a new type of workflow engine aims at supporting more workflows, we consider that it only requires re-implementing interaction g in this architecture ($E_1 = 1$). Note, however, that implementing interaction g can require substantial work depending on the complexity of the workflow language used by the new engine. Similarly, adding a new engine version only requires modifying interaction g ($E_2 = 1$). Adding a new workflow is done through interactions a_1 , a_2 and g ($E_3 = 3$). As in the service architecture, interfacing with a new infrastructure requires modifications in interactions a_1 , b , c_1 and c_2 ($E_4 = 4$).

Scalability. Since workflow conversion is not involved in the execution (it is an offline process), the score is the same as for the service architecture ($S_1 = 1$, $S_2 = 1$, $S_3 = 0$).

Functionality. Meta-workflows are available after conversion, by connecting workflows in the language used in the science gateway ($F_{1=0}$). Debugging information is accessible as in the service invocation architecture ($F_{2=1}$).

6. Discussion

6.1. Comparison between architectures

Tight integration and task encapsulation are the simplest architectures to integrate, followed by service integration, workflow conversion (with service invocation) and pool. Nested workflows (with service invocation) require more integration than the other architectures. Robustness roughly leads to the same ordering of architectures, with tight integration and task encapsulation in the top group, service integration and workflow conversion (with service invocation) close behind, pool in a third group, and nested workflows (with service invocation) at the end. This ordering is consistent across metrics; it reflects the global complexity of the architectures.

Regarding extensibility, most architectures are overall comparable, except nested workflows (with service invocation) which are significantly behind. This is explained by the complexity of the nested workflow architecture, with 2 infrastructures and 2 workflow services. Task encapsulation and workflow conversion (with service invocation) perform slightly better when integrating new engines (E_1), which makes them useful architectures for science gateways that do not focus on a particular engine. However, task encapsulation, workflow conversion (with service invocation) and tight integration perform worse than the others when adding engine versions (E_2), due to the need to update infrastructure (task encapsulation), science gateway (tight integration), or workflow converter (workflow conversion). Workflow conversion performs worse than the others when integrating new workflows (E_3) because of the language conversion step. All architectures except nested workflows are equivalent when integrating new infrastructures (E_4).

The pool architecture is overall the most scalable, which is not surprising since it is designed precisely for scalability. Tight integration is the least scalable and all the other architectures perform the same overall. The global scalability score, however, should not conceal the unique characteristics of architectures regarding this criterion. Nested workflows are the only architecture that can easily accommodate distributed workflow execution, which can be critical in some cases. At the same time, the scheduling constraints created by task encapsulation and nested workflows may become problematic depending on the type of targeted infrastructure. Non-reliable infrastructures, for example, could hardly cope with workflow engines being wrapped in computing tasks as done in task encapsulation. The availability of multiple engine instances could also become a critical feature for science gateways with important workloads, which would favor task encapsulation and pool.

Differences in functionality should not be neglected. Nested workflows (with service invocation) and workflow conversion (with service invocation) are the only architectures that intrinsically support meta-workflows. Besides, tight integration is the only architecture that allows fine-grained debugging, which may be critical for efficient user support.

Table 3 provides an overall comparison between architectures, based on the metrics in Table 2. It should be noted that this analysis is only meant for illustration purposes, since it assumes that all criteria have equal weights while real systems would favor some of them. Weights can be adjusted in the public spreadsheet at <https://frama.link/LrPRsCQp> (column B of sheet “Metrics”) to produce a custom version of Table 3 if required.

Overall, task encapsulation and workflow conversion perform a bit better than the other architectures and nested workflows stand a bit behind for the reasons mentioned previously.

Table 3

Overall evaluation. Brighter colors and lower scores indicate better performance. Scores are obtained by summing the normalized global scores (m' values) of each criterion in Table 2 and the colors are obtained as in Table 2.

	Tight	Service	Task	Pool	Nested Service+Service	Conversion
Integration (global score)	0.00	0.22	0.00	0.44	1.00	0.33
Robustness (global score)	0.14	0.43	0.00	0.71	1.00	0.43
Extensibility (global score)	0.44	0.22	0.00	0.22	1.00	0.22
Scalability (global score)	1.00	0.50	0.50	0.00	0.50	0.50
Functionality (global score)	0.00	1.00	1.00	1.00	0.00	0.00
	1.6	2.4	1.5	2.4	3.5	1.5

6.2. Limitations

A few limitations should be considered when using the results of our evaluation. First, our evaluation methods aimed to provide comparative metrics, however the high-level of abstraction used to derive these metrics hinders the complexity of real systems to some extent. In particular, the presented architectures are abstract patterns that may be mixed together in actual systems. The distinction between tight integration and service invocation, for instance, may not always be that clear in practice. Service invocation may also be combined with task encapsulation in some cases. Nevertheless, the criteria discussed in this work would still be applicable for broadly comparing and categorizing such cases of hybrid architectures.

It should also be noted that all the interactions involved in the architectures were treated equally, whereas some of them are obviously more complex than others. For example, interaction *g* (workflow language conversion) is clearly more complex than interaction *d* (service invocation). However, without entering into the details of a particular system, quantification of the robustness or the amount of development associated with each interaction and software component will hardly be precise. If a particular system is evaluated, the public spreadsheet can be used to adjust the weights given to specific components and interactions based on the technical context.

The particular case of interaction *g* (workflow language conversion) requires particular attention when implementing a real system since this interaction may not be easily generalized to any workflow language. For instance, converting FSL, PSOM or Nipype pipelines to any other workflow language is problematic because these engines rely on general-purpose programming languages such as Bash, Octave/Matlab and Python, which are much richer than scientific workflow languages. If not properly validated, workflow language conversion could introduce critical errors impacting the robustness and correctness of the execution.

The abstract nested workflows and workflow conversion patterns were instantiated with service invocation so that they can be analyzed in the same framework as the other architectures. Other types of instantiation, for instance nested workflows with task encapsulation, could also be envisaged. We chose to limit ourselves to instantiations with service invocation because the resulting architectures have already been implemented in real systems, and because service invocation is largely used. Nevertheless, it could be interesting to explore other types of instantiations.

The particular technical or historical context of a science gateway project may also influence the evaluation of an architecture to integrate workflow engines. For instance, many workflow engines are already available as web services, which tends to favor service invocation (in particular when interactions can be re-purposed), and other science gateways may have strongly tested task and data control features (interactions *b* and *c*₁), which would favor task encapsulation. Similarly, adding a new type of engine may facilitate integration of a new infrastructure when interactions *b* and

*c*₂ are already available. The migration cost between architectures has been ignored as well.

Finally, workflow engines are only one of the many aspects involved in the design of a science gateway. Other properties definitely influence the design of a software architecture, for instance collaborative features, data visualization, search, authentication, accounting and so on.

7. Application to systems design

To illustrate how our evaluation framework can be applied to help design new systems, let us consider a hypothetical system where the workflow engine is split in two parts: (1) a high-level part integrated in the science gateway, which submits sub-workflows to the infrastructure; (2) a lower-level part, executed on the infrastructure, which executes the sub-workflows. This scenario came up after the evaluation framework had already been designed.

We model such a system using a nested workflow architecture with a “Tight+Task” instantiation, i.e., the parent engine is tightly integrated in the science gateway and the child engine is integrated through task encapsulation. Fig. 9 shows the graphical representation of the system. From this representation we find that the sub-tasks submitted by the child engine through interaction *e* should be handled by the parent engine rather than by the science gateway. Indeed, handling the tasks directly in the science gateway would lead to create a new specific interaction, named, e.g., *b*₁, while *b* could be reused. We also find that interaction *e* allows running the sub-tasks on the infrastructure(s) supported by the parent engine with no further development effort required in the child engine.

The system evaluation is presented in Table 4. The detailed calculations are available in our public spreadsheet at <https://frama.link/LrPRsCQp>. We conclude that the studied system supports nested workflows with a much better performance than the nested workflow model instantiated with service invocation (evaluated in Table 2): the integration score is improved by a factor of 2, robustness is improved by a factor of 2.6, extensibility is substantially improved, scalability and functionality are not penalized.

8. Related work

There is abundant literature describing specific workflow engines and systems; some of the main references are cited in Section 1.1. A few works described the architecture and features of workflow systems at an abstract level. For instance, the early work [49] proposes a generic architecture for grid workflow systems that is based on the workflow reference model defined by the Workflow Management Coalition.⁶ Deelman et al. [16] have

⁶ <http://www.wfmc.org>.

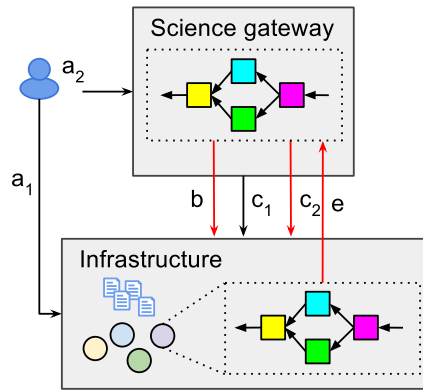

Fig. 9. Nested workflow architecture instantiated with tight integration and task encapsulation (Tight+Task).

further characterized the features of workflow systems. These two works, however, do not mention science gateways.

Numerous science gateways have been described, as mentioned in Section 1.2. However, only a few works focused on science gateway architectures. Shahand et al. [50] presents the Science Gateway Canvas, which is a business reference model where the most relevant functional components are organized into functional groups. Although workflow management is mentioned as a possible component to coordinate distributed computations in science gateways, the paper does not comment on architecture to achieve this.

Olabarriaga et al. [48] presents a user-centered view of the ecosystem of science gateways with focus on workflow management. Their proposed layered system architecture includes gateway, workflow engine and distributed infrastructure components, similarly to the “service invocation” pattern. However other patterns are not identified.

9. Conclusion

We have systematically reviewed architectures used to integrate workflow engines in science gateways. These architectures were described in a system-independent framework suitable for comparison, illustrated on real systems, and evaluated using novel quantitative metrics that allow simple comparison across architectures. We have discussed the pros and cons of all the presented architectures based on these metrics, and we have shown how our evaluation framework can be leveraged in the design of new systems.

To the best of our knowledge, our work is the first to systematically review and compare software architectures to integrate workflow engines into science gateways. So far, the literature on science gateways and workflow engines has focused on the description of particular systems, or on the presentation of a particular architecture. Instead, our analysis abstracts and evaluates architectural patterns independently from any particular system, providing general insight about ways to integrate science gateways and workflow engines. These insights will be valuable for software architects when considering alternatives for the architecture and evaluating the impact of their decisions.

Acknowledgments

We thank the anonymous reviewers for the thorough reviews and useful comments that greatly contributed to improve the quality of this paper. This work has been made possible with the

Table 4

Evaluation of the nested workflow architecture instantiated with tight integration (parent engine) and task encapsulation (child engine).

	Nested Tight+Task
Integration complexity	
Total components— I_1	2
Total interactions— I_2	6
Total	8
Robustness	
Specific components— R_1	0
Specific interactions— R_2	3
Total	3
Extensibility	
New engine type— E_1	3
New engine version— E_2	1
New workflow— E_3	2
New infrastructure— E_4	4
Total	10
Scalability	
Multiple engine instances— S_1	1
Distributed engines— S_2	0
Task scheduling— S_3	1
Total	2
Functionality	
Meta-workflow— F_1	0
Fine-grained debugging— F_2	1
Total	1

support of the Irving Ludmer Family Foundation and the Ludmer Centre for Neuroinformatics and Mental Health. The integration between PSOM and CBRAIN was supported by a Brain Canada Platform Support Grant, as well as the Canadian Consortium on Neurodegeneration in Aging (CCNA), through a grant from the Canadian Institute of Health Research and funding from several partners. This work is in the scope of the LABEX PRIMES (ANR-11-LABX-0063) of Université de Lyon, within the program “Investissements d’Avenir” (ANR-11-IDEX-0007) operated by the French National Research Agency (ANR). This work also falls into the scope of the scientific topics of the French National Grid Institute (IdG). The VIP team thanks the site administrators of the European Grid Initiative and the GGUS support for their help related to the VIP platform. The CBRAIN team is grateful for the computing cycles, storage, and support obtained from Compute Canada (<https://computecanada.ca>) and platform development program from CANARIE (<http://www.canarie.ca/>). We also acknowledge the Dutch national e-Infrastructure with the support of SURF Cooperative, the Dutch national program COMMIT and the High Performance Computing and Networking (HPCN) Fund of the University of Amsterdam for their support to the science gateway activities at the AMC. We are also grateful to the financial support provided by FP7 E-INFRASTRUCTURE program for financial support to SCI-BUS, SHIWA and ER-flow projects.

References

- [1] Tarek Sherif, Pierre Rioux, Marc-Etienne Rousseau, Nicolas Kassis, Natacha Beck, Reza Adalat, Samir Das, Tristan Glatard, Alan C. Evans, CBRAIN: a web-based, distributed computing platform for collaborative neuroimaging research, *Front. Neuroinf.* 8 (54) (2014).
- [2] Shayan Shahand, Ammar Benabdelkader, Mohammad Mahdi Jaghoori, Mostapha al Mourabit, Jordi Huguet, Matthan W.A. Caan, Antoine H.C. Kampen, Silvia D. Olabarriaga, A data-centric neuroscience gateway: design, implementation, and experiences, *Concurr. Comput.: Pract. Exper.* 27 (2) (2015) 489–506.
- [3] Shayan Shahand, Mark Santcroos, Antoine H.C. vanKampen, Silvia Olabarriaga, A grid-enabled gateway for biomedical data analysis, *J. Grid Comput.* 10 (4) (2012) 725–742.

- [4] T. Glatard, C. Lartizien, B. Gibaud, R. Ferreira da Silva, G. Forestier, F. Cervenansky, M. Alessandrini, H. Benoit-Cattin, O. Bernard, S. Camarasu-Pop, N. Cerezo, P. Clarysse, A. Gaignard, P. Hugonnard, H. Liebgott, S. Marache, A. Marion, J. Montagnat, J. Tabary, D. Friboulet, A virtual imaging platform for multi-modality medical image simulation, *IEEE Trans. Med. Imaging* 32 (1) (2013) 110–118.
- [5] Thomas Fahringer, Radu Prodan, Rubing Duan, Francesco Nerieri, Stefan Podlipnig, Jun Qin, Mumtaz Siddiqui, Hong-Linh Truong, Alex Villazon, Marek Wiczorek, Askalon: A grid application development and computing environment, in: *Proceedings of the 6th IEEE/ACM International Workshop on Grid Computing*, IEEE Computer Society, 2005, pp. 122–131.
- [6] Bartosz Balis, Hyperflow: A model of computation, programming approach and enactment engine for complex distributed workflows, *Future Gener. Comput. Syst.* 55 (2016) 147–162.
- [7] T. Glatard, J. Montagnat, D. Lingrand, X. Pennec, Flexible and efficient workflow deployment of data-intensive applications on grids with MOTEUR, *J. High Perform. Comput. Appl.* 22 (3) (2008) 347–360.
- [8] Ewa Deelman, Gurmeet Singh, Mei-Hui Su, James Blythe, Yolanda Gil, Carl Kesselman, Gaurang Mehta, Karan Vahi, G. Bruce Berriman, John Good, et al., Pegasus: A framework for mapping complex scientific workflows onto distributed systems, *Sci. Program.* 13 (3) (2005) 219–237.
- [9] Ewa Deelman, Karan Vahi, Gideon Juve, Mats Rynge, Scott Callaghan, Philip J. Maechling, Rajiv Mayani, Weiwei Chen, Rafael Ferreira da Silva, Miron Livny, Kent Wenger, Pegasus, a workflow management system for science automation, *Future Gener. Comput. Syst.* 46 (2015) 17–35.
- [10] Yong Zhao, Mihael Hategan, Ben Clifford, Ian Foster, Gregor Von Laszewski, Veronika Nefedova, Ioan Raicu, Tiberiu Stef-Praun, Michael Wilde, Swift: Fast, reliable, loosely coupled parallel computation, in: *IEEE Congress on Services*, 2007, pp. 199–206.
- [11] Tom Oinn, Matthew Addis, Justin Ferris, Darren Marvin, Martin Senger, Mark Greenwood, Tim Carver, Kevin Glover, Matthew R. Pocock, Anil Wipat, et al., Taverna: a tool for the composition and enactment of bioinformatics workflows, *Bioinformatics* 20 (17) (2004) 3045–3054.
- [12] Ian Taylor, Matthew Shields, Ian Wang, Andrew Harrison, *The Triana workflow environment: Architecture and applications*, in: *Workflows for e-Science*, Springer, 2007, pp. 320–339.
- [13] S.P. Callahan, J. Freire, J. Freire, E. Santos, C.E. Scheidegger, C.T. Silva, Huy T. Vo, Managing the evolution of dataflows with vistrails, in: *22nd International Conference on Data Engineering Workshops (ICDEW'06)*, 2006, pp. 71–71.
- [14] Peter Kacsuk, Zoltan Farkas, Miklos Kozlovsky, Gabor Hermann, Akos Balasko, Krisztian Karoczkai, Istvan Marton, WS-PGRADE/gUSE generic DCI gateway framework for a large variety of user communities, *J. Grid Comput.* 10 (4) (2012) 601–630.
- [15] V. Korkhov, D. Vasyunin, A. Wibisono, V. Guevara-Masis, A. Belloum, C. de Laat, P. Adriaans, L.O. Hertzberger, WS-VLAM: Towards a scalable workflow system on the grid, in: *Proceedings of the 2nd workshop on Workflows in Support of Large-Scale Science (WORKS07)*, 16th IEEE International Symposium on High Performance Distributed Computing, 2007, pp. 63–68.
- [16] Ewa Deelman, Dennis Gannon, Matthew Shields, Ian Taylor, *Workflows and e-Science: An overview of workflow system features and capabilities*, *Future Gener. Comput. Syst.* 25 (5) (2009) 528–540.
- [17] Krzysztof Gorgolewski, Christopher D. Burns, Cindee Madison, Dav Clark, Yaroslav O. Halchenko, Michael L. Waskom, Satrajit S. Ghosh, Nipype: a flexible, lightweight and extensible neuroimaging data processing framework in Python, *Front. Neuroinf.* 5 (3) (2011).
- [18] Pierre Bellec, Sébastien Lavoie-Courchesne, Phil Dickinson, Jason Lerch, Alex Zijdenbos, Alan C. Evans, The Pipeline System for Octave and Matlab (PSOM) a lightweight scripting framework and execution engine for scientific workflows, *Front. Neuroinf.* 6 (7) (2012).
- [19] Y. Ad-Dabbagh, D. Einarson, O. Lyttelton, J.-S. Muehlboeck, K. Mok, O. Ivanov, R.D. Vincent, C. Lepage, J. Lerch, E. Fombonne, A.C. Evans, The CIVET image-processing environment: A fully automated comprehensive pipeline for anatomical neuroimaging research, in: *Proceedings of the 12th Annual Meeting of the Organization for Human Brain Mapping*, 2006.
- [20] A.P. Zijdenbos, R. Forghani, A.C. Evans, Automatic “pipeline” analysis of 3-D MRI data for clinical trials: application to multiple sclerosis, *IEEE Trans. Med. Imaging* 21 (10) (2002) 1280–1291.
- [21] John Ashburner, SPM: A history, *NeuroImage* 62 (2) (2012) 791–800.
- [22] Mark Jenkinson, Christian F. Beckmann, Timothy E.J. Behrens, Mark W. Woolrich, Stephen M. Smith, FSL, *NeuroImage* 62 (2) (2012) 782–790.
- [23] Suresh Marru, Lahiru Gunathilake, Chathura Herath, Patanachai Tangchaisin, Marlon Pierce, Chris Mattmann, Raminder Singh, Thilina Gunarathne, Eran Chinthaka, Ross Gardler, et al., Apache Airavata: a framework for distributed applications and computational workflows, in: *Proceedings of the 2011 ACM Workshop on Gateway Computing Environments*, ACM, 2011, pp. 21–28.
- [24] Valeria Ardizzone, Roberto Barbera, Antonio Calanducci, Marco Fargetta, E. Ingrà, Ivan Porro, Giuseppe La Rocca, Salvatore Monforte, R. Ricceri, Riccardo Rotondo, et al., The DECIDE science gateway, *J. Grid Comput.* 10 (4) (2012) 689–707.
- [25] Peter Kacsuk, *Science Gateways for Distributed Computing Infrastructures*, Springer, 2014.
- [26] Tania Lorido-Bostrán, José Miguel-Alonso, Jose Antonio Lozano, Auto-scaling techniques for elastic applications in cloud environments, *Tech. Rep. EHU-KAT-IK-09*, 12, Department of Computer Architecture and Technology, University of Basque Country, 2012.
- [27] Sharath Maddineni, Joohyun Kim, Yaakoub El-Khamra, Shantenu Jha, Distributed application runtime environment (DARE) a standards-based middleware framework for science-gateways, *J. Grid Comput.* 10 (4) (2012) 647–664.
- [28] Ivo D. Dinov, John D. Van Horn, Kamen M. Loez, Rico Magsipoc, Petros Petrosyan, Zhizhong Liu, Allan MacKenzie-Graham, Paul Eggert, Douglas S. Parker, Arthur W. Toga, Efficient, distributed and interactive neuroimaging data analysis using the LONI pipeline, *Front. Neuroinf.* 3 (22) (2009).
- [29] Michael McLennan, Steven Clark, Ewa Deelman, Mats Rynge, Karan Vahi, Frank McKenna, Derrick Kearney, Carol Song, HUBzero and Pegasus: integrating scientific workflows into science gateways, *Concurr. Comput.: Pract. Exper.* 27 (2) (2015) 328–343.
- [30] Wenjun Wu, Thomas Uram, Michael Wilde, Mark Hereld, Michael E. Papka, Accelerating science gateway development with Web 2.0 and Swift, in: *Proceedings of the 2010 TeraGrid Conference*, ACM, 2010, p. 23.
- [31] Dawid Szejnfeld, Piotr Dziubecki, Piotr Kopta, Michal Krysinski, Tomasz Kuczynski, Krzysztof Kurowski, Bogdan Ludwiczak, Tomasz Piontek, Dominik Tarnawczyk, Malgorzata Wolniewicz, Piotr Domagalski, Jaroslaw Nabrzyski, Krzysztof Witkowski, Vine Toolkit - Towards portal based production solutions for scientific and engineering communities with grid-enabled resources support, *Scalable Comput.: Pract. Exp.* 11 (2) (2010).
- [32] Ekaterina Elts, Ioan Lucian Muntean, Hans-Joachim Bungartz, High Performance Computing in Science and Engineering, Garching/Munich 2009: Trans-actions of the Fourth Joint HLRB and KONWIHR Review and Results Workshop, Dec. 8–9, 2009, Leibniz Supercomputing Centre, Garching/Munich, Germany, Springer, Berlin, Heidelberg, 2010, pp. 651–662. (Chapter) Grid Workflows for Molecular Simulations in Chemical Industry.
- [33] T. Glatard, P.O. Quirion, R. Adalat, N. Beck, R. Bernard, B.L. Caron, Q. Nguyen, P. Rioux, M.-E. Rousseau, A.C. Evans, P. Bellec, Integration between PSOM and CBRAIN for distributed execution of neuroimaging pipelines, in: *Meeting of the Organization for Human Brain Mapping*, Geneva, Switzerland, 2016.
- [34] D. Rogers, I. Harvey, T.T. Huu, K. Evans, T. Glatard, I. Kallel, I. Taylor, J. Montagnat, A. Jones, A. Harrison, Bundle and pool architecture for multi-language, robust, scalable workflow executions, *J. Grid Comput.* 11 (3) (2013) 457–480.
- [35] Gabor Terstyanszky, Tamas Kukla, Tamas Kiss, Peter Kacsuk, Akos Balasko, Zoltan Farkas, Enabling scientific workflow sharing through coarse-grained interoperability, *Future Gener. Comput. Syst.* 37 (2014) 46–59.
- [36] Mohamed Abouelhoda, Shadi Alaa Issa, Moustafa Ghanem, Tavaxy: Integrating Taverna and Galaxy workflows with cloud computing support, *BMC Bioinformatics* 13 (1) (2012) 1–19.
- [37] Kassian Plankensteiner, Radu Prodan, Matthias Janetschek, Thomas Fahringer, Johan Montagnat, David Rogers, Ian Harvey, Ian Taylor, Akos Balasko, Péter Kacsuk, Fine-Grain interoperability of scientific workflows in distributed computing infrastructures, *J. Grid Comput.* 11 (3) (2013) 429–456.
- [38] Luis de la Garza, Johannes Veit, Andras Szolek, Marc Röttig, Stephan Aiche, Sandra Gesing, Knut Reinert, Oliver Kohlbacher, From the desktop to the grid: scalable bioinformatics via workflow conversion, *BMC Bioinformatics* 17 (1) (2016) 1–12.
- [39] Tom Goodale, Shantenu Jha, Hartmut Kaiser, Thilo Kielmann, Pascal Kleijer, Gregor Von Laszewski, Craig Lee, Andre Merzky, Hrabir Rajic, John Shalf, SAGA: A simple API for grid applications. High-level application programming on the grid, *Comput. Methods Sci. Technol.* 12 (1) (2006) 7–20.
- [40] Peter Tröger, Roger Brobst, Daniel Gruber, Mariusz Mamonski, Daniel Templeton, Distributed resource management application API Version 2 (DRMAA), in: *Technical report*, Open Grid Forum, January 2012. Also available online: <http://www.ogf.org/documents/GFD.194.pdf>, 2012.
- [41] Andy Edmonds, Thijs Metsch, Alexander Papaspyrou, Alexis Richardson, Toward an open cloud standard, *IEEE Internet Comput.* 16 (4) (2012) 15–25.
- [42] Sylvain Reynaud, Uniform access to heterogeneous grid infrastructures with JSAGA, in: *Production grids in Asia*, Springer, 2010, pp. 185–196.
- [43] Akos Hajnal, Zoltán Farkas, Péter Kacsuk, Data avenue: remote storage resource management in WS-PGRADE/gUSE, in: *6th International Workshop on Science Gateways (IWSG)*, IEEE, 2014, pp. 1–5.
- [44] Matteo Turilli, Mark Santcross, Shantenu Jha, A comprehensive perspective on the pilot-job abstraction, preprint arXiv:1508.04180, 2015.
- [45] S. Olabarriaga, T. Glatard, A. Hoheisel, A. Nederveen, D. Krefting, Crossing healthgrid borders: Early results in medical imaging, in: *HealthGrid'09*, pages 62–71, Berlin, jun 2009.
- [46] Jeremy Goecks, Anton Nekrutenko, James Taylor, et al., Galaxy: a comprehensive approach for supporting accessible, reproducible, and transparent computational research in the life sciences, *Genome Biol.* 11 (8) (2010) R86.
- [47] Michael R. Berthold, Nicolas Cebron, Fabian Dill, Thomas R. Gabriel, Tobias Kötter, Thorsten Meinel, Peter Ohl, Christoph Sieb, Kilian Thiel, Bernd Wiswedel, *Data Analysis, Machine Learning and Applications: Proceedings of the 31st Annual Conference of the Gesellschaft für Klassifikation e.V.*, Albert-Ludwigs-Universität Freiburg, March 7–9, 2007, Springer Berlin, Heidelberg, Berlin, Heidelberg, 2008, pp. 319–326. (Chapter) KNIME: The Konstanz Information Miner.

- [48] Silvia Olabarriaga, Gabrielle Pierantoni, Giuliano Taffoni, Eva Sciacca, Mahdi Jaghoori, Vladimir Korkhov, Giuliano Castelli, Claudio Vuerli, Ugo Becciani, Eoin Carley, et al., Scientific workflow management—for whom ? in: 2014 IEEE 10th International Conference on e-Science, (e-Science), IEEE, 2014, pp. 298–305.
- [49] J. Yu, R. Buyya, A taxonomy of workflow management systems for grid computing, *J. Grid Comput.* 3 (3–4) (2005) 171–200.
- [50] Shayan Shahand, Antoine H.C. van Kampen, Silvia D. Olabarriaga, Science gateway canvas: A business reference model for science gateways, in: Proceedings of the Science of Cyberinfrastructure: Research, Experience, Applications and Models, SCREAM'15, Portland, OR, USA, 2015.



Tristan Glatard obtained a Ph.D. in Computer-Science from the University of Nice Sophia-Antipolis in 2007. In 2008, he spent a year as a post-doctoral fellow at the University of Amsterdam, working in the Virtual-Lab for e-Science project. From 2008 to 2016, he was a researcher at CNRS in Lyon, working on distributed systems for medical imaging. From 2013 to 2016, he was also a Visiting Scholar at the McGill University in Montreal, working in the CBRAIN team. He is now Assistant Professor in the Department of Computer Science and Software Engineering at Concordia University in Montreal.



Marc-Étienne Rousseau since 2008 is the technical manager for the CBRAIN Platform Team hosted in the Montreal Neurological Institute, McGill University. Before joining Dr. Evans' group, M. Rousseau was the Coordinator of Scientific IT at the McGill Life Sciences Complex, after a few crucial formative years within the West Coast Biotechnology Industry and the IBM Pacific Development Center. His dual formation in both Life Sciences & Computer Science, allow him to renew the often fragile links between the two scientific communities.



Sorina Camarasu-Pop received her Engineering degree in Telecommunications in 2007 and her Ph.D. degree (on exploiting heterogeneous distributed systems for Monte-Carlo simulations in the medical field) in 2013, both from the National Institute for Applied Sciences of Lyon (INSA-Lyon, France). Since 2007 she is a CNRS research engineer at Creatis in Lyon, France. Her activity is focused on optimizing the execution of medical image processing applications on heterogeneous distributed systems.



Reza Adalat has over 27 years of experience as the Director of the Operations for Academia and Telecommunications industry and before that as a precision systems architect and design engineer for Aerospace industry. During his tenure at McGill University, he has been involved as Director of the Operations and the Senior Programs Manager in projects related to neuroinformatics and information technologies for automated neuroimaging research in large-scale clinical and developmental studies. Among these projects are large multi-center, multi-million dollars, brain imaging research studies, funded

by US National Institute of Health (NIH), International consortium for Brain Mapping (ICBM), Neuroimaging InFormatics Technology Initiative (NIFTI), US Autism Centers of Excellence (ACE) Network, Canadian Institute of Health Research (CIHR), Canada Foundation for Innovation (CFI), Canada's Advanced Research and Innovation Network (CANARIE), Canadian Brain Research And Informatics Network (CBRAIN), Helmholtz Association of German Research Centers, Canada Networks of Centers of Excellence (NeuroDevNet), National University of Singapore (NUS), The Irving Ludmer Family Foundation, Jean Coutu Family Foundation, European Commission Human Brain Project (HBP) and Brain Canada Foundation. Reza Adalat is a multilingual, highly organized, dynamic and goal-oriented team leader, with successful interpersonal communication skills.



Natacha Beck has been a software developer at MCIN since 2011; she has a formation and background in bioinformatics. She previously worked at the University of Montreal on some genetic annotation pipeline and she used to annotate mitochondrial genome. At the MCIN she works on the CBRAIN platform and a web-based software that allows neuroimaging researchers to perform computationally intensive analyses on data by connecting them to High-Performance Computing (HPC).



Samir Das began working at the Montreal Neurological Institute in 2002 and currently serves as Software Manager for the McGill Centre for Integrative Neuroscience. He is also the system architect for the LORIS data platform (www.loris.ca), which stewards and curates several data initiatives, such as the longitudinal NIH MRI Study of Normal Brain Development (Evans et al., 2006), the IBIS autism network (Wolff et al., 2012), BigBrain (www.bigbrain.loris.ca) and numerous international longitudinal studies. His background is in Mathematics and Computing Science (University of Alberta), and has dedicated a great deal of time to various neuroimaging efforts and collaborations, both in terms of pipeline processing as well as neuroimaging analysis.



Rafael Ferreira da Silva is a Computer Scientist in the Collaborative Computing Group at the USC Information Sciences Institute. His research interest include scientific workflows, cloud and grid computing, data science, distributed computing, reproducibility, and machine learning. He received his Ph.D. in Computer Science from INSA-Lyon, France, in 2013. In 2010, he received his Master's degree in Computer Science from Universidade Federal de Campina Grande, Brazil, and his B.S. degree in Computer Science from Universidade Federal da Paraíba, in 2007. See <http://www.rafaelsilva.com> for further information.



Najmeh Khalili-Mahani, Neuroscientist specializing in pharmacological neuroimaging, currently research associate at MCIN, McGill University, bioinformatics advisor at PERFORM Centre, Concordia University, and Adjunct Professor in the Department of Psychology, Concordia University, Montreal, QC.



Vladimir Korkhov is an associate professor at the Computer Modeling and Multiprocessor Systems department, Faculty of Applied Mathematics and Control Processes, St. Petersburg State University, Russia. He received Ph.D. degree from the University of Amsterdam in 2009 with the thesis on hierarchical resource management in Grid computing; he participated in a number of national and international projects on distributed and grid computing, in particular Virtual laboratory (2001–2004, NL), VL-e: Virtual laboratory for e-Science (2004–2009, NL), High performance simulation on the Grid (2004–2006, NL-RU), SHIWA: Sharing Interoperable Workflows for large scale scientific simulations on Available DCIs (2010–2012, EU FP7), ER-flow (2012–2014, EU FP7). As a post-doctoral researcher he worked at the Academic Medical Center of the University of Amsterdam and at Charité—Medical University of Berlin on applying grid technology to bioinformatics and medical applications. Research interests include parallel, distributed, grid and cloud computing, resource management, workflows. Dr. Korkhov has published around 70 scientific papers in international journals and conference proceedings.

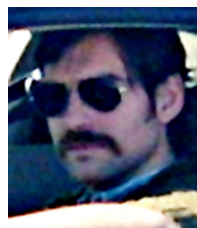

Pierre-Olivier Quirion completed a Ph.D. in Astrophysics in 2006. In all, he spent about ten years studying evolution and seismology of white dwarfs and solar like stars. He followed this period with a two years stint in the film industry, working as a Technical Director in charge of distributed computing in the dynamic environment of Computer Graphic Image (CGI) production. It is with this eclectic background, always lined with high performance computing, that Dr. Quirion joined the CRIUGM in 2015 as a member of the SIMEXP, Neurophys and UNF labs where he develops software for MRI analysis and distributed computing and act as a goto specialist for all things computer related.



Pierre Rioux is a computer scientist who has worked in brain imaging for the past 7 years, and was previously involved in genomics research in different organizations in and around Montreal, Canada, and Palo Alto, USA. He is particularly crazy when he writes about himself at the third person.



Silvia D. Olabbarriaga after being active in various fields and organizations, since 2009, is Assistant Professor of the Department of Clinical Epidemiology, Biostatistics and Bioinformatics of the Academic Medical Center of the University of Amsterdam. She leads the e-science research line, supervises Ph.D. students, and teaches courses at the AMC Graduate School and Medical Informatics Bachelor and Master Programs. Silvia is mainly interested in the usage of advanced information technology for scientific biomedical research, such as e-infrastructures, in particular through usable science gateways. Her research covers a broad range of topics including distributed computing and research data management for medical applications. Currently Silvia is also advisor to the president of the Hospital de Clinicas de Porto Alegre, Brazil, on topics related to data-driven research in biomedicine and clinical data management. Google Scholar: <http://scholar.google.nl/citations?user=TQIIXtkAAAAJ&hl=en&oi=ao>.



Pierre Bellec is an assistant Professor at the Computer Science and Operations Research (DIRO) department and the Institute of Geriatrics (CRIUGM) at University of Montreal, Canada, since 2010. Previously, he was a post-doctoral Fellow at the McConnell Brain Imaging Centre, Montreal Neurological Institute, Canada (2006–2010). He received a Ph.D. degree in medical imaging (physics), from University Paris XI, Orsay, France (2006) and a M.Sc. in mathematics, vision and learning at Ecole Normale Supérieure, Cachan, France (2002). His main research interest is to develop image processing and data mining algorithms for the identification of neuroimaging biomarkers in Alzheimer's disease.



Alan C. Evans is James McGill Professor of Neurology and Psychiatry at McGill University. His research covers multi-modal brain imaging, structural network modeling and neuroinformatics (www.mcin.ca). He is co-Director the Ludmer Centre for Neuroinformatics and Mental Health, where he uses high-performance computing to integrate imaging, behavior, genetics and epigenetics data in brain research. He has 534 peer-reviewed papers (ISI h-index = 118; Google Scholar h-index = 163). In 2014, he received the Vezina Prize for Quebec Neuroradiology, the national Margolese Human Brain Disorders Prize and was a Highly Cited Scientist (top 1%) for Neuroscience and Behavior. He is a Fellow of the Royal Society of Canada and 2016 Chair of the Organization for Human Brain Mapping.