



**HAL**  
open science

# Experimental evidence of a fundamental noise floor at the tens of millihertz level in laser locking onto unbalanced fibre-based Michelson interferometer

Frédéric Audo, Jean-Pierre Coulon, Fabien Kéfélian

## ► To cite this version:

Frédéric Audo, Jean-Pierre Coulon, Fabien Kéfélian. Experimental evidence of a fundamental noise floor at the tens of millihertz level in laser locking onto unbalanced fibre-based Michelson interferometer. 2017 Conference on Lasers and Electro-Optics Europe a& European Quantum Electronics Conference, Jun 2017, Munich, Germany. , 2017. hal-01569144

**HAL Id: hal-01569144**

**<https://hal.science/hal-01569144>**

Submitted on 26 Jul 2017

**HAL** is a multi-disciplinary open access archive for the deposit and dissemination of scientific research documents, whether they are published or not. The documents may come from teaching and research institutions in France or abroad, or from public or private research centers.

L'archive ouverte pluridisciplinaire **HAL**, est destinée au dépôt et à la diffusion de documents scientifiques de niveau recherche, publiés ou non, émanant des établissements d'enseignement et de recherche français ou étrangers, des laboratoires publics ou privés.

Copyright



# Experimental evidence of a fundamental noise floor at the tens of millihertz level in laser locking onto unbalanced fibre-based Michelson interferometer

F. Audo, J.P. Coulon, F. Kéfélian

Laboratoire ARTEMIS, Observatoire de la Côte d'Azur & Université Côte d'Azur & CNRS, Nice, France,  
Contact : fabien.kefelian@oca.eu

## Introduction

- General context** : Spectral transfer of coherence with transfer-interferometer

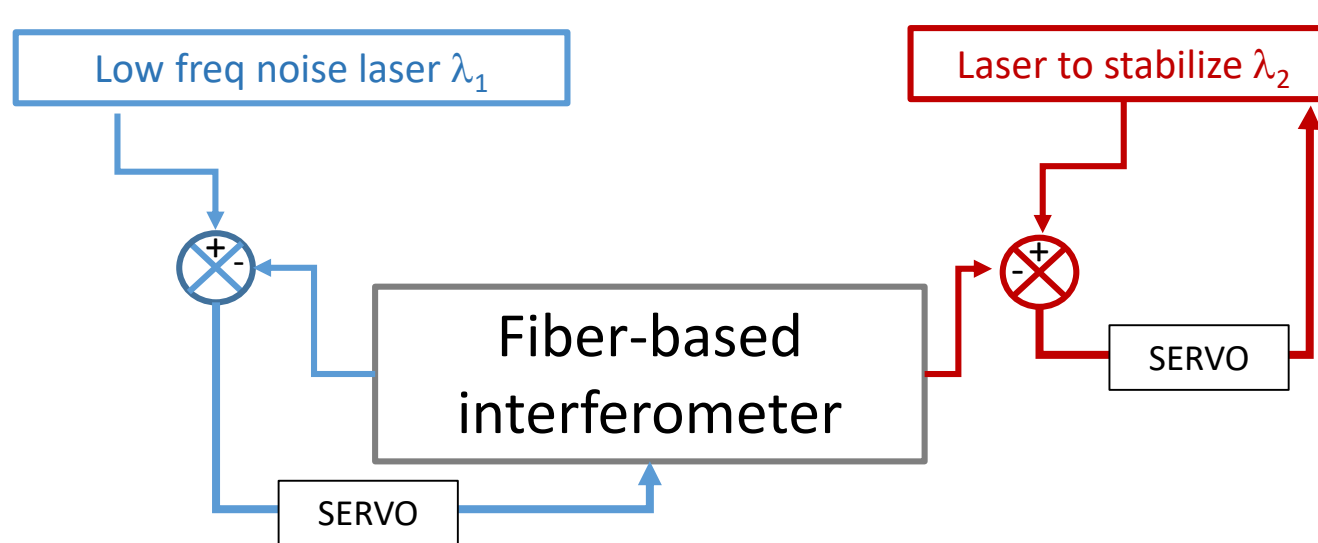

Same principle than transfer cavity but with fiber based interferometer

- Fiber based interferometer** : compact two-arm interferometer with large length imbalance using fiber spool

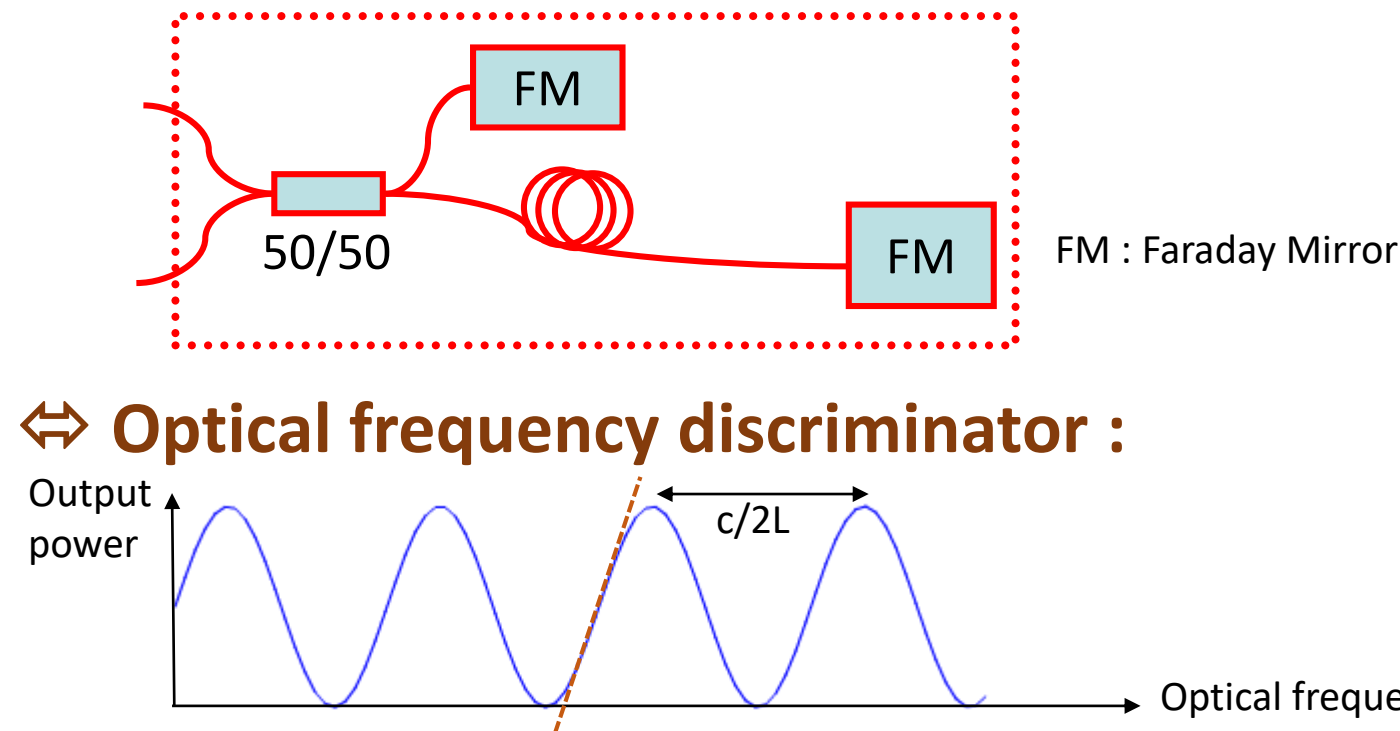

1 km spool  $\Leftrightarrow$  10-cm Fabry-Perot cavity with F=50 000

- High potential for short term laser frequency stabilization** :

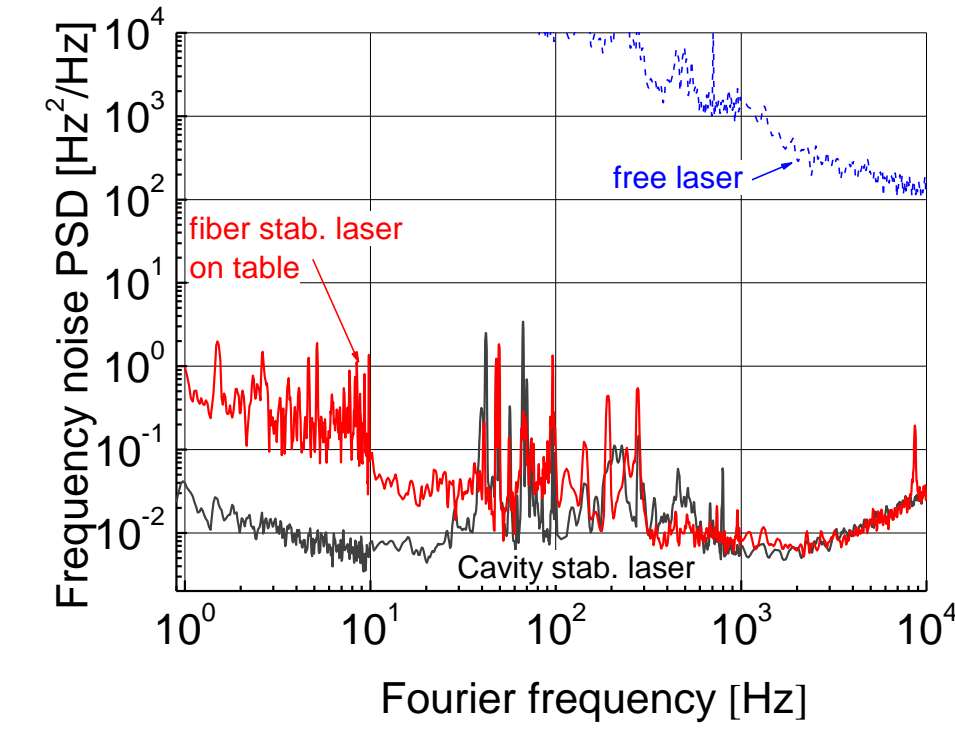

Frequency noise of laser stabilized onto 1-km fiber spool with passive isolation  
- Kéfélian et al. Opt.Lett (2009)  
- Jiang et al. Opt. Exp. (2009)

Good stability of one mode  $\Rightarrow$  Very good stability between modes

## Initial goal and experimental setting

- Initial goal** : To measure the frequency noise floor when two lasers are locked onto two modes of an interferometer with very low optical frequency difference ( $< 20$  GHz)
- Experimental aspects and measurement principles** :
  - 2 RIO narrow linewidth diode lasers @ 1542 nm with 300 MHz difference
  - Michelson interferometer with Faraday mirrors and a 300-m optical fiber
  - Dual locking using Pound-Drever-Hall technique with 2 different PM frequencies and 1 single low noise transimpedance photodetector
  - Laser frequency controller using AOM or combined action on laser current and EOM
  - Down-conversion of the beat note to 57 MHz and frequency noise analysis with VCO-PLL based frequency-to-voltage converter and FFT signal analyzer

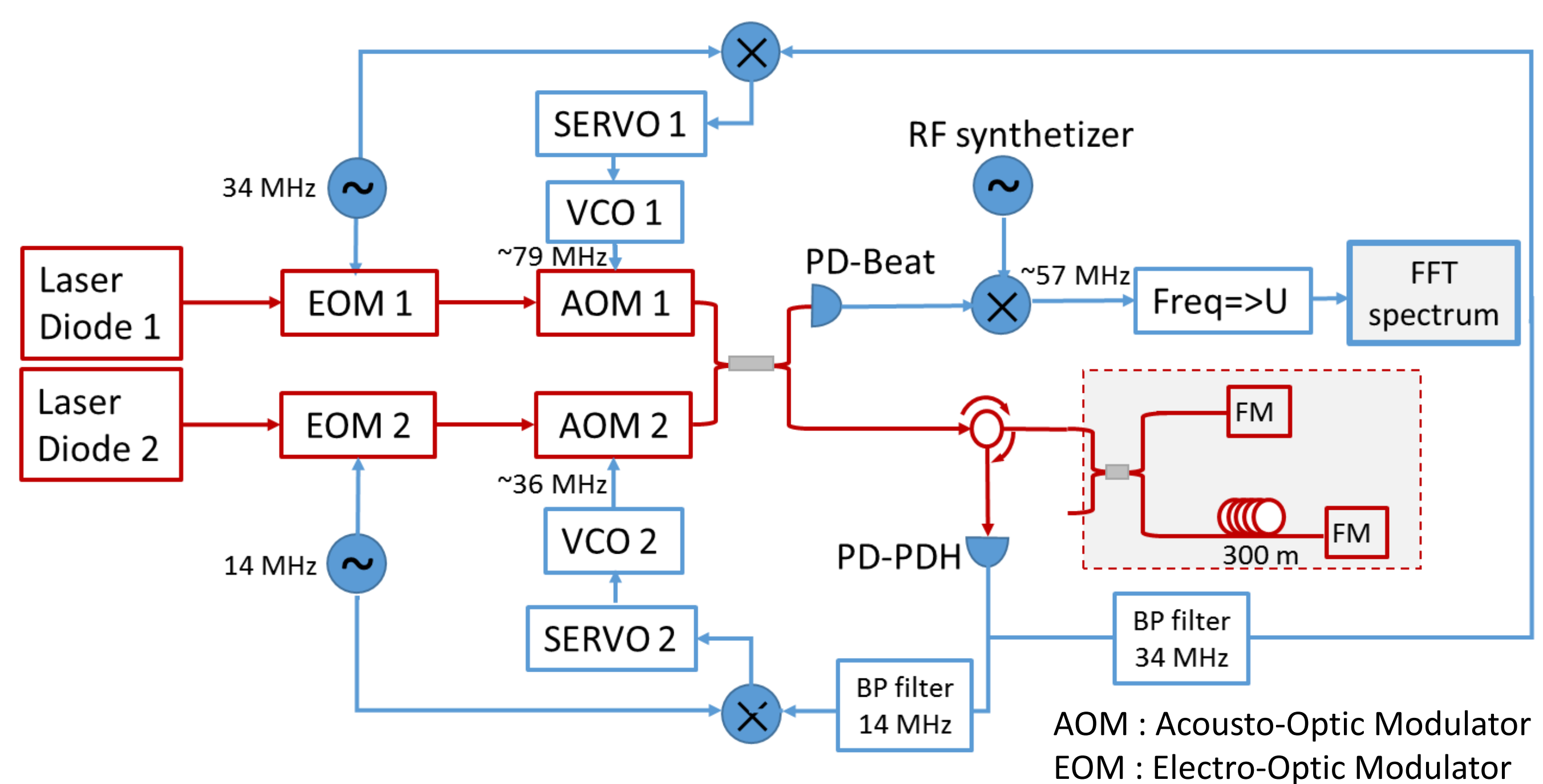

## In loop noise (error signal)

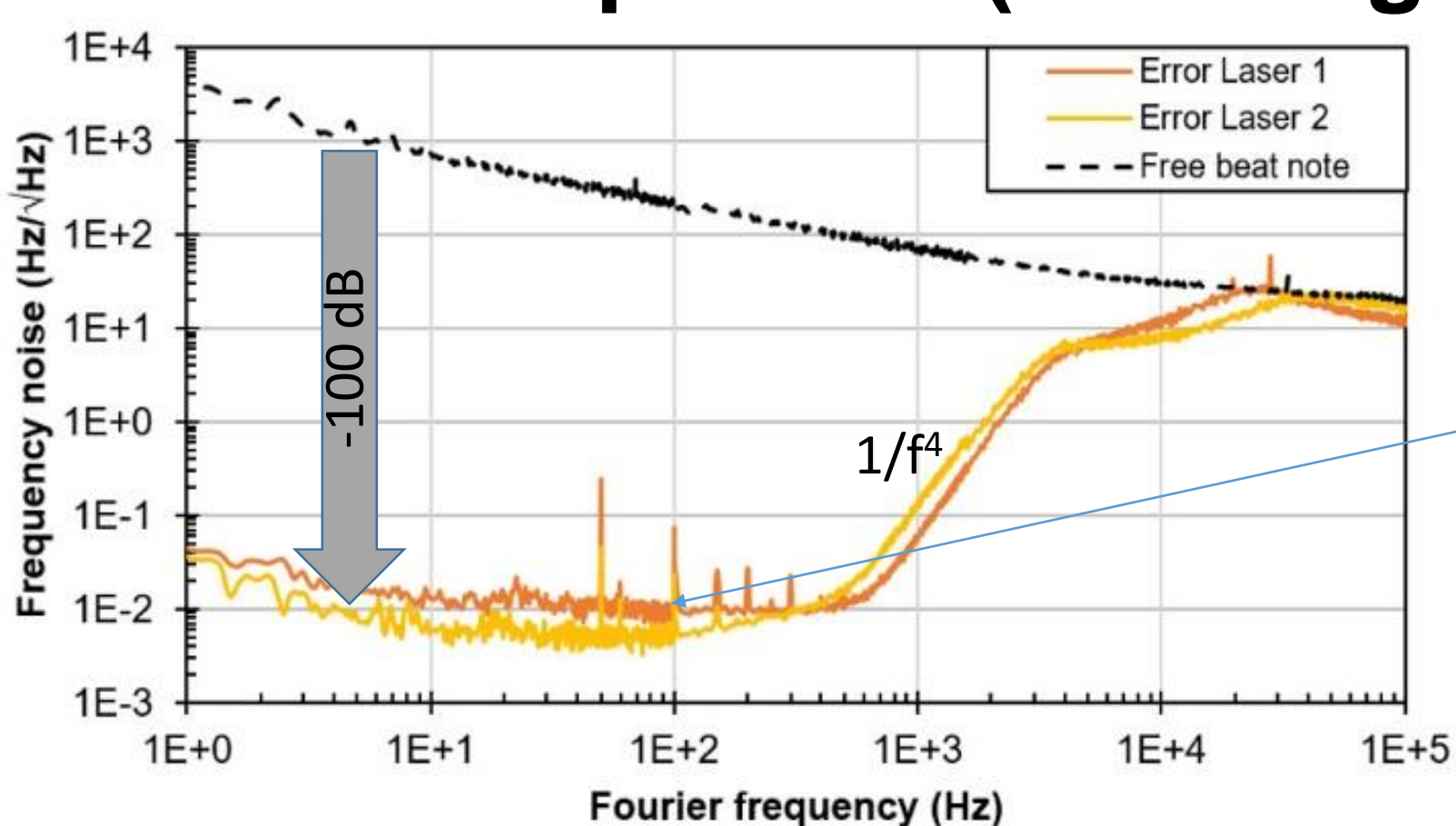

In loop frequency noise floor  $< 10^{-2}$  Hz/√Hz ( $\Leftrightarrow 3$  nV/√Hz at the mixer output)

## Out-of-loop noise (beat note frequency)

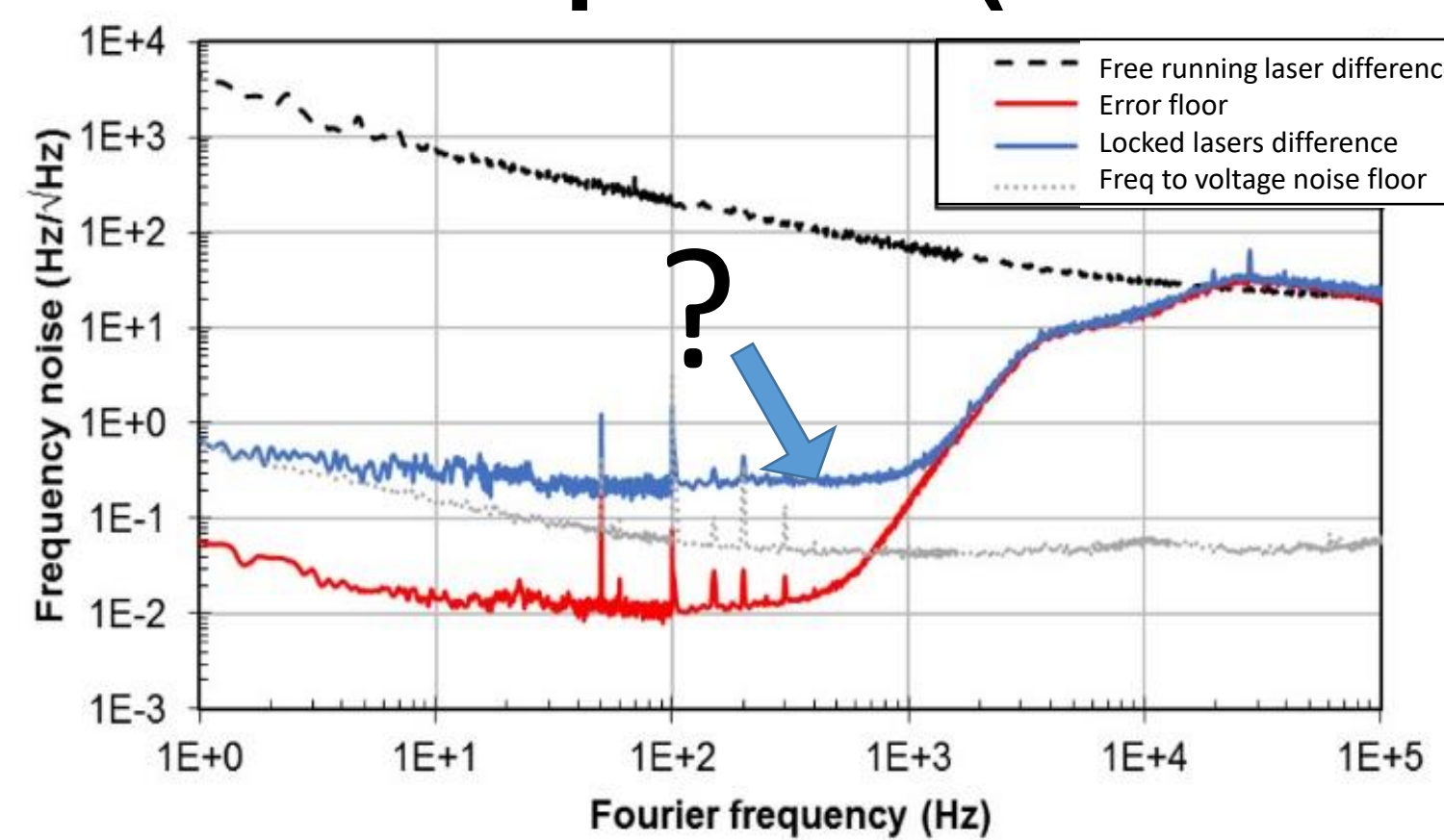

Experimental evidence of an out-of-loop frequency white noise  $> 10^{-1}$  Hz/√Hz with unknown origin

- o Fiber noise ? NO
- o Shot noise ? NO
- o Photodetector noise ? NO
- o EOM residual amplitude noise ? NO
- o Diaphonia between the two PDH error signals ? NO
- o Diode laser residual secondary modes ? NO
- o Electronic saturation ? NO
- o Rayleigh backscattering ? NO

## Experimental evidence of the origin of the white noise

Sinus modulation at tens of kHz generates low frequency white noise with level proportional to the square of the tone amplitude

Only non-linear effect can explain such behavior

**Interferometer optical frequency discriminator residual non linearity**

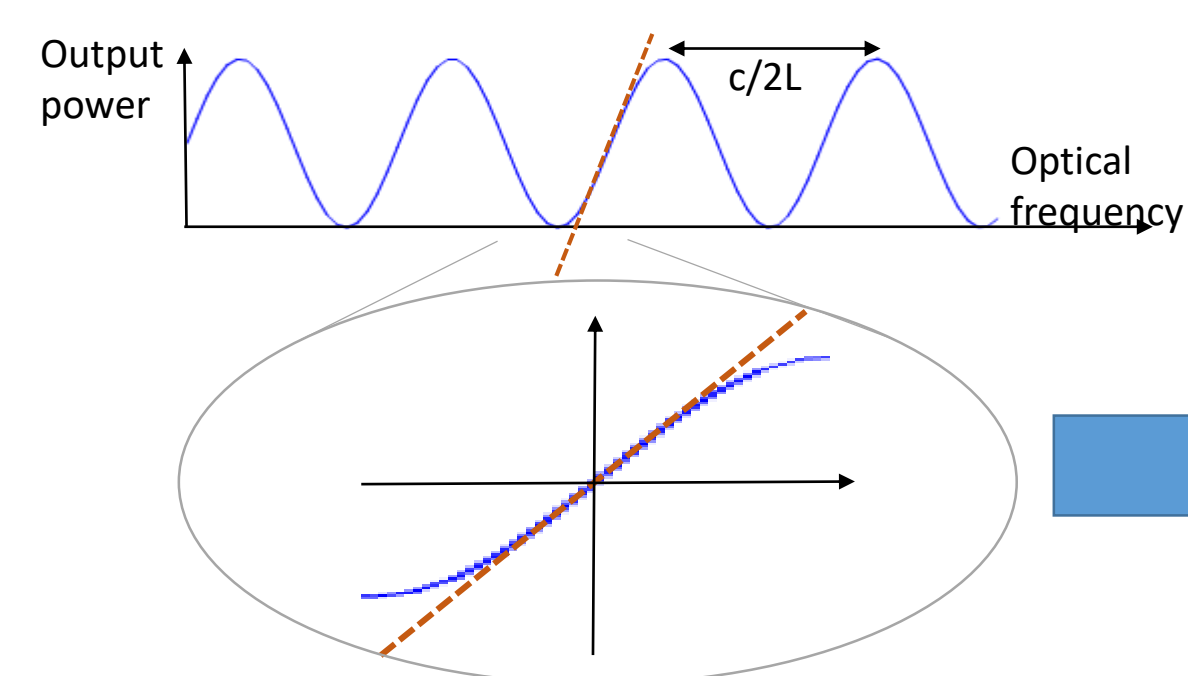

**Non linear servo loop**

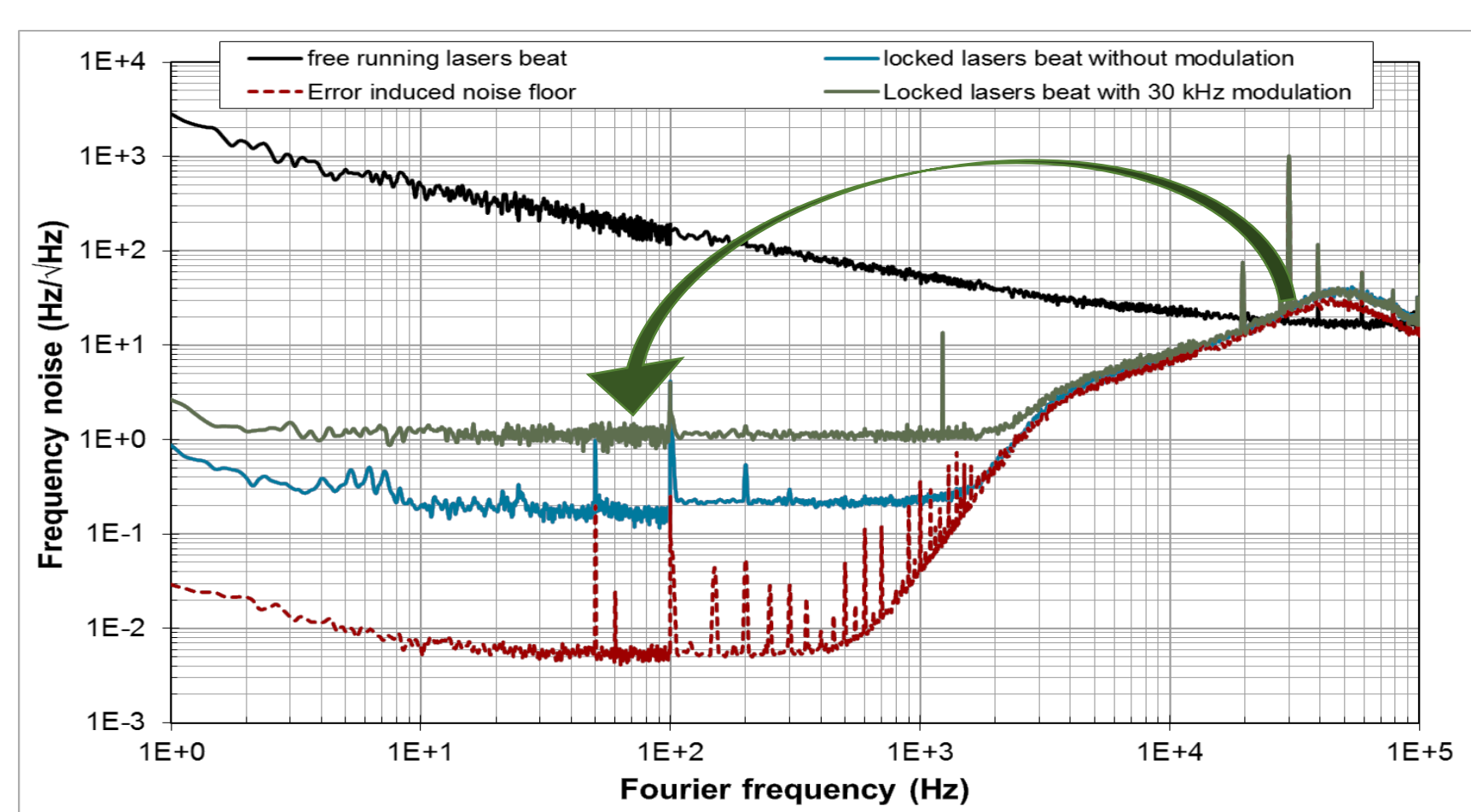

- Numerical simulation of the effect of the non linearity of the frequency discriminator on the noise spectrum** :

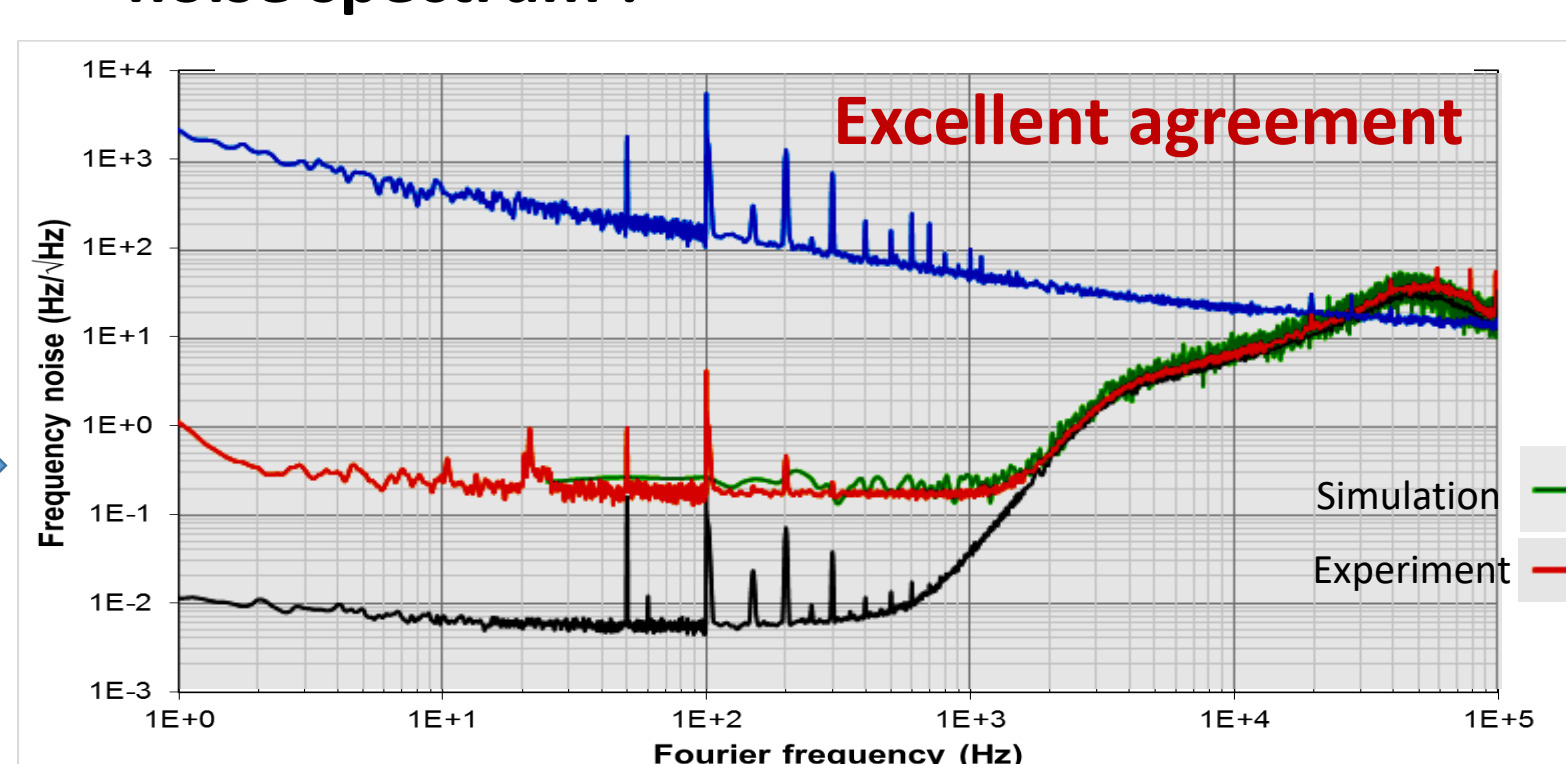

$$\sin(x) \approx x - x^3/6 + O(x^5)$$

$$\text{Out of loop} \rightarrow \frac{(U_{\max}/6)/(2\pi/ISL)^2}{\delta v^2}$$

## Noise floor and fiber length

Noise generation by the residual non linearity depends on :

**Error signal**  
**Free spectral range**

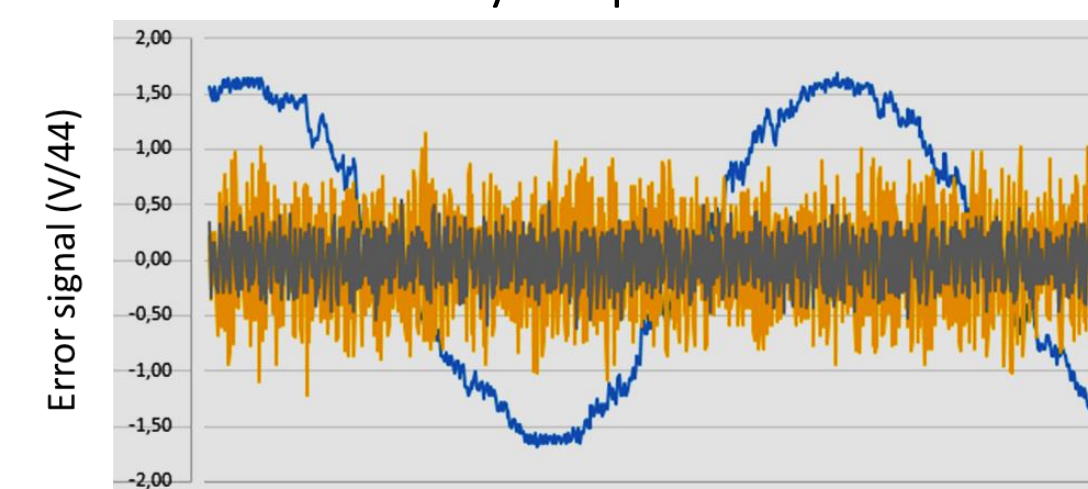

Noise floor should decrease with the fiber length

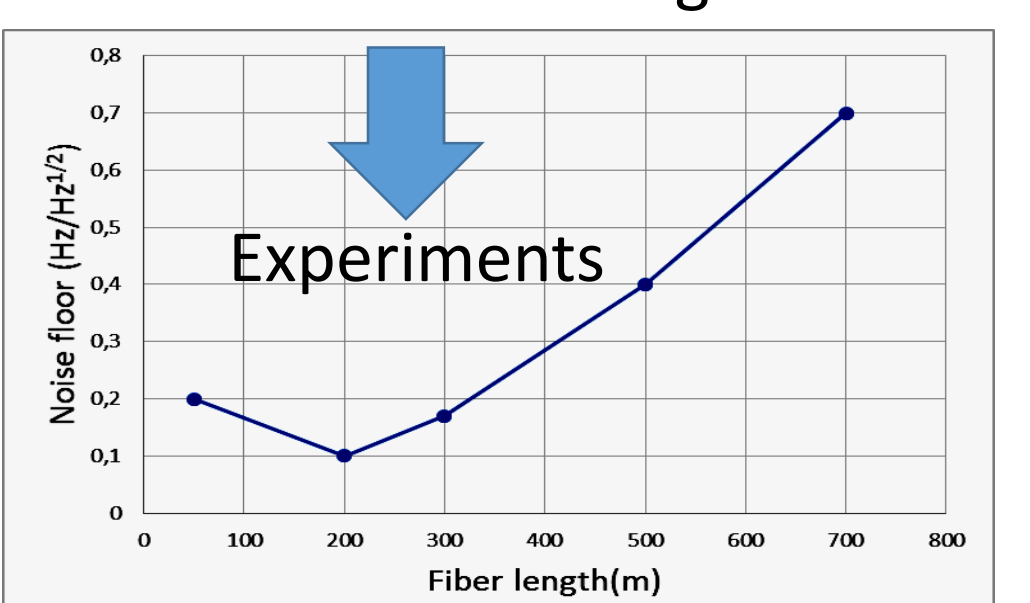

Noise floor increases at short fiber length ???

$1/f$  Frequency response of the discriminator depends on fiber length

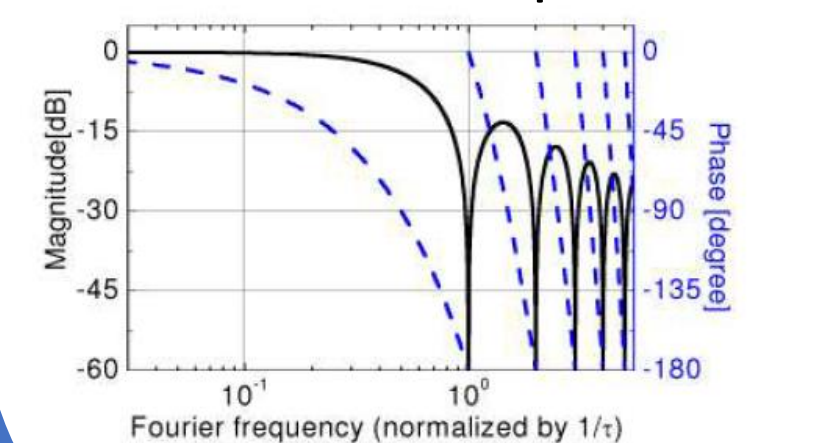

Shorter fiber gives more error signal at high frequencies

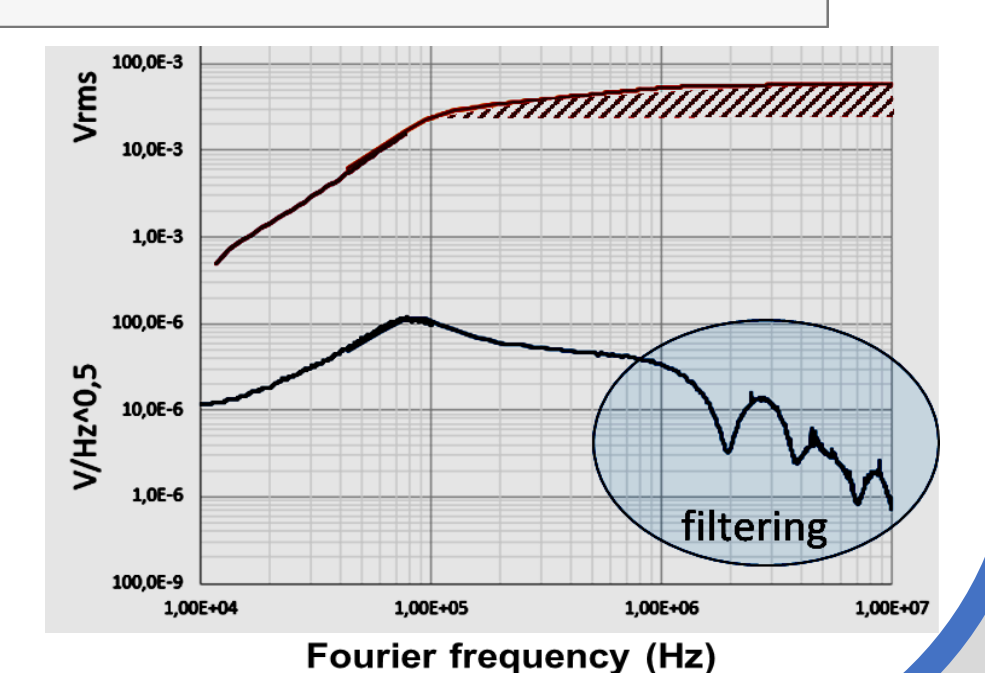

## Conclusion

- First experimental evidence of the impact of non linearity of optical frequency discriminator on low noise laser stabilization
- Result can be generalized to frequency stabilization on Fabry-Perot cavity and more generally to all stabilization (ex: power stabilization)
- Numerical simulation can predict the level of white noise generated by the non linearity
- Non linear electronic compensation could remove this noise