



**HAL**  
open science

# Simultaneous Information and Energy Transmission in Gaussian Interference Channels with Feedback

Nizar Khalfet, Samir Perlaza

► **To cite this version:**

Nizar Khalfet, Samir Perlaza. Simultaneous Information and Energy Transmission in Gaussian Interference Channels with Feedback. 2017. hal-01561756v1

**HAL Id: hal-01561756**

**<https://hal.science/hal-01561756v1>**

Preprint submitted on 13 Jul 2017 (v1), last revised 9 Oct 2017 (v2)

**HAL** is a multi-disciplinary open access archive for the deposit and dissemination of scientific research documents, whether they are published or not. The documents may come from teaching and research institutions in France or abroad, or from public or private research centers.

L'archive ouverte pluridisciplinaire **HAL**, est destinée au dépôt et à la diffusion de documents scientifiques de niveau recherche, publiés ou non, émanant des établissements d'enseignement et de recherche français ou étrangers, des laboratoires publics ou privés.

# Simultaneous Information and Energy Transmission in Gaussian Interference Channels with Feedback

Nizar Khalfet and Samir M. Perlaza

**Abstract**—In this paper, the fundamental limits of simultaneous information and energy transmission in the two-user Gaussian interference channel with feedback are fully characterized. More specifically, an achievable and converse region in terms of information and energy transmission rates (in bits per channel use and energy-units per channel use, respectively) are presented. The achievable region is obtained using a combination of rate splitting, power-splitting, common randomness, superposition coding and block Markov decoding. Finally, the converse region is obtained using some of the existing outer bounds for the information transmission rates, as well as a new outer bound for the energy transmission rate.

## I. GAUSSIAN INTERFERENCE CHANNEL WITH ENERGY HARVESTER

Consider the Gaussian interference channel with a non-colocated energy harvester with feedback depicted in Fig. 1. Transmitter  $i$ , with  $i \in \{1, 2\}$ , aims to execute two tasks: (a) an information transmission task and (b) an energy transmission task.

### A. Information Transmission Task

From the information transmission standpoint, the goal of transmitter  $i$  is to convey an independent message index  $W_i \in \mathcal{W}_i$  to receiver  $i$  using  $N$  channel input symbols  $X_{i,1}, X_{i,2}, \dots, X_{i,N}$ . The channel coefficient from transmitter  $k$  to receiver  $i$ , with  $k \in \{1, 2\}$ , is denoted by  $h_{ik} \in \mathbb{R}_+$ . At receiver  $i$ , during channel use  $n$ , input symbol  $X_{i,n}$  is observed at receiver  $i$  subject to the interference produced by the symbol  $X_{j,n}$  sent by transmitter  $j$ , with  $j \in \{1, 2\} \setminus \{i\}$ , and a real additive Gaussian noise  $Z_{i,n}$  with zero mean and variance  $\sigma_i^2$ . Hence, the channel output at receiver  $i$  during channel use  $n$ , denoted by  $Y_{i,n}$ , is

$$Y_{i,n} = h_{ii}X_{i,n} + h_{ij}X_{j,n} + Z_{i,n}. \quad (1)$$

At each channel use  $n$ , the symbol  $X_{i,n}$  sent by transmitter  $i$  depends on the message index  $W_i$ , a randomly generated index  $\Omega \in \mathbb{N}$ , and all previous channel-outputs  $Y_{i,1}, Y_{i,2}, \dots, Y_{i,n-d}$ , with  $d \in \mathbb{N}$  the feedback delay. In the following, it is assumed that  $d = 1$  channel use, without any loss of generality. The first channel input symbol  $X_{i,1}$  depends only on the message

index  $W_i$  and  $\Omega \in \mathbb{N}$ . More specifically,  $f_{i,1}^{(N)} : \mathcal{W}_i \times \mathbb{N} \rightarrow \mathbb{R}$  and for all  $n \in \{2, 3, \dots, N\}$ ,  $f_{i,n}^{(N)} : \mathcal{W}_i \times \mathbb{N} \times \mathbb{R}^{n-1} \rightarrow \mathbb{R}$  are the encoding functions such that:

$$X_{i,1} = f_{i,1}^{(N)}(W_i, \Omega) \quad (2)$$

and for all  $n \in \{2, \dots, N\}$ ,

$$X_{i,n} = f_{i,n}^{(N)}(W_i, \Omega, Y_1, \dots, Y_{n-1}). \quad (3)$$

The random index  $\Omega$  is assumed to be independent of both  $W_1$  and  $W_2$  and known by all transmitters and receivers. Channel input symbols  $X_{i,1}, X_{i,2}, \dots, X_{i,N}$  are subject to an average power constraint of the form

$$\frac{1}{N} \sum_{n=1}^N \mathbb{E}[X_{i,n}^2] \leq P_i, \quad (4)$$

where  $P_i$  denotes the average transmit power of transmitter  $i$  in energy units per channel use. The expectation in (4) is taken with respect to  $W_i$ ,  $\Omega$ , and the previous channel outputs  $Y_1, \dots, Y_{n-1}$ . Note that  $W_i$  and  $\Omega$  are assumed to be uniformly distributed over their corresponding sets.

Let  $T \in \mathbb{N}$  be fixed and assume that during a given communication,  $T$  blocks of  $N$  channel uses are transmitted. The decoder of receiver  $i$  observes the channel outputs  $Y_{i,1}, Y_{i,2}, \dots, Y_{i,NT}$  and uses a decoding function

$$\phi_i : \mathbb{N} \times \mathbb{R}^{NT} \rightarrow \{1, 2, \dots, 2^{R_i}\}^T, \quad (5)$$

to get an estimate of the message indices:

$$\left( \widehat{W}_i^{(1)}, \widehat{W}_i^{(2)}, \dots, \widehat{W}_i^{(T)} \right) = \phi_i(\Omega, Y_{i,1}, Y_{i,2}, \dots, Y_{i,NT}), \quad (6)$$

where  $\widehat{W}_i^{(t)}$  is an estimate of the message index sent during block  $t \in \{1, 2, \dots, T\}$ . The decoding error probability during block  $t$  of a codebook of block-length  $N$ , denoted by  $P_e^{(t)}(N)$ , is given by

$$P_e^{(t)}(N) = \max \left( \Pr \left[ \widehat{W}_1^{(t)} \neq W_1^{(t)} \right], \Pr \left[ \widehat{W}_2^{(t)} \neq W_2^{(t)} \right] \right). \quad (7)$$

The signal to noise ratio (SNR) at receiver  $i$  is denoted by

$$\text{SNR}_i = \frac{|h_{ii}|^2 P_i}{\sigma_i^2}. \quad (8)$$

The interference to noise ratio (INR) at receiver  $i$  is denoted by

$$\text{INR}_i = \frac{|h_{ij}|^2 P_j}{\sigma_i^2}, \quad (9)$$

with  $j \neq i$ .

Nizar Khalfet and Samir M. Perlaza are with the Laboratoire CITI (a joint laboratory between the Université de Lyon, INSA de Lyon, and INRIA), 6 Avenue des Arts, F-69621, Villeurbanne, France. ({samir.perlaza, nizar.khalfet}@inria.fr).

Samir M. Perlaza is also with the Department of Electrical Engineering at Princeton University, Princeton, NJ.

This research was supported in part by the European Commission under Marie Skłodowska-Curie Individual Fellowship No. 659316 and Euro-Mediterranean Cooperation ERA-NET project COM-MED.

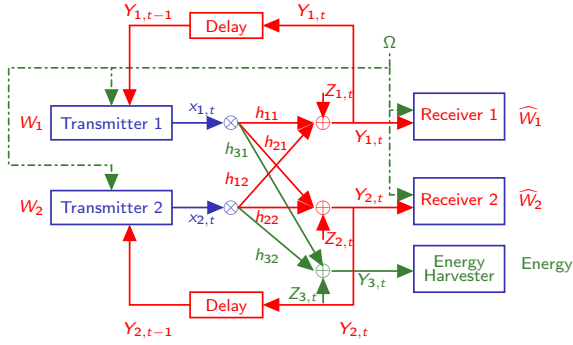

Fig. 1. Two-user Gaussian interference channel with a non-located energy harvester.

### B. Energy Transmission Task

Let  $h_{3i} \in \mathbb{R}_+$  be the channel coefficient from transmitter  $i$  to the energy harvester (EH). The symbols sent by the transmitters are observed by the EH subject to an additive Gaussian noise  $Z_{3,n}$  with zero mean and variance  $\sigma_3^2$ . More specifically, the channel output at the EH, denoted by  $Y_{3,n}$ , is

$$Y_{3,n} = h_{31}X_{1,n} + h_{32}X_{2,n} + Z_{3,n}. \quad (10)$$

From the energy transmission standpoint, the goal of both transmitters is to jointly guarantee an average energy rate at the EH. Let  $b \geq 0$  denote the minimum average energy rate that must be guaranteed at the input of the EH. Let also  $B^{(N)}$  be the average energy rate (in energy-units per channel use) at the end of  $N$  channel uses. That is,

$$B^{(N)} \triangleq \frac{1}{N} \sum_{n=1}^N Y_{3,n}^2. \quad (11)$$

The SNR of transmitter  $i$  at the EH is denoted by

$$\text{SNR}_{3i} = \frac{|h_{3i}|^2 P_i}{\sigma_3^2}. \quad (12)$$

Note that the maximum average energy rate  $B_{\max}$  is

$$B_{\max} = \sigma_3^2 \left( 1 + \text{SNR}_{31} + \text{SNR}_{32} + 2\sqrt{\text{SNR}_{31}\text{SNR}_{32}} \right). \quad (13)$$

The probability of energy outage, given an average energy rate  $B$ , is defined as follows:

$$P_{\text{outage}}^{(N,\epsilon)}(B) \triangleq \Pr [B^{(N)} < B - \epsilon], \quad (14)$$

for all  $B > b$  and some  $\epsilon > 0$ .

### C. Simultaneous Information and Energy Transmission (SIET)

Given a minimum energy rate  $b$  to be satisfied at the EH, the system is said to be operating at the information-energy rate triplet  $(R_1, R_2, B) \in \mathbb{R}_+^3$  when both transmitter-receiver pairs use a transmit-receive configurations such that: (i) reliable communication at information rates  $R_1$  and  $R_2$  is ensured; and (ii) reliable energy transmission at energy rate  $B$  is ensured. A formal definition is given below.

**Definition 1 (Achievable Rates):** The triplet  $(R_1, R_2, B) \in \mathbb{R}_+^3$  is achievable if for all  $i \in \{1, 2\}$ , there exists a sequence

of encoding functions  $f_{i,1}^{(N)}, f_{i,2}^{(N)}, \dots, f_{i,N}^{(N)}$  and a decoding function  $\phi_i$  such that both the average error probability  $P_e^{(t)}(N)$ , for all  $t \in \{1, 2, \dots, T\}$ , and the energy-outage probability  $P_{\text{outage}}^{(N,\epsilon)}(B)$  tend to zero as the block-length  $N$  tends to infinity. That is,

$$\limsup_{N \rightarrow \infty} P_e^{(N)} = 0, \text{ and} \quad (15)$$

$$\limsup_{N \rightarrow \infty} P_{\text{outage}}^{(N,\epsilon)} = 0. \quad (16)$$

Using Definition 1, the fundamental limits of simultaneous information and energy transmission in the Gaussian interference channel can be described by the information-energy capacity region, defined as follows.

**Definition 2 (Information-Energy Capacity Region):** The information-energy capacity region given a minimum energy rate  $b$ , denoted by  $\mathcal{E}_b^{\text{F}}$ , corresponds to the closure of all achievable information-energy rate triplets  $(R_1, R_2, B)$ .

## II. MAIN RESULTS

The main result consists of a description of the information-energy capacity region  $\mathcal{E}_b^{\text{F}}$ , for a given  $b \geq 0$ . Such a description is presented in the form of an approximation in the sense of the definition hereunder.

**Definition 3 (Approximation of a Set):** Let  $n \in \mathbb{N}$  be fixed. A closed and convex region  $\mathcal{X} \subset \mathbb{R}_+^n$  is approximated by the sets  $\underline{\mathcal{X}}$  and  $\overline{\mathcal{X}}$  if  $\underline{\mathcal{X}} \subseteq \mathcal{X} \subseteq \overline{\mathcal{X}}$  and  $\forall \mathbf{x} = (x_1, \dots, x_n) \in \overline{\mathcal{X}}$  then  $((x_1 - \xi_1)^+, (x_1 - \xi_2)^+, \dots, (x_n - \xi_n)^+) \in \underline{\mathcal{X}}$ , for some  $(\xi_1, \xi_2, \dots, \xi_n) \in \mathbb{R}_+^n$ .

The following sections show that the information-energy capacity region  $\mathcal{E}_b^{\text{F}}$ , with  $b$  any positive real number, is approximated by the regions  $\underline{\mathcal{E}}_b^{\text{F}}$  (Theorem 1) and  $\overline{\mathcal{E}}_b^{\text{F}}$  (Theorem 2).

### A. Achievability

The following theorem describes a set of rate-tuples that are achievable (Definition 1).

**Theorem 1:** Let  $b$  be a fixed positive real. Then, the information-energy capacity region  $\mathcal{E}_b$  contains all the rate tuples  $(R_1, R_2, B)$  that satisfy for all  $i \in \{1, 2\}$  and  $j \in \{1, 2\} \setminus \{i\}$ :

$$R_i \leq \frac{1}{2} \log \left( \frac{1 + (1 - \lambda_{ie}) \text{SNR}_i + (1 - \lambda_{je}) \text{INR}_i + 2\rho \sqrt{\text{SNR}_i \text{INR}_i}}{1 + \lambda_{jp} \text{INR}_i} \right), \quad (17a)$$

$$R_i \leq \frac{1}{2} \log \left( \frac{1 + (1 - (\rho + \lambda_{ie})) \text{INR}_j}{1 + \lambda_{ip} \text{INR}_j} \right) + \frac{1}{2} \log \left( \frac{1 + \lambda_{ip} \text{SNR}_i + \lambda_{jp} \text{INR}_i}{1 + \lambda_{jp} \text{INR}_i} \right), \quad (17b)$$

$$R_1 + R_2 \leq \frac{1}{2} \log \left( \frac{1 + \lambda_{ip} \text{SNR}_i + \lambda_{jp} \text{INR}_i}{1 + \lambda_{jp} \text{INR}_i} \right)$$

$$+\frac{1}{2} \log \left( \frac{1+(1-\lambda_{je})\text{SNR}_j+(1-\lambda_{ie})\text{INR}_j+2\rho\sqrt{\text{SNR}_j\text{INR}_j}}{1+\lambda_{ip}\text{INR}_j} \right), \quad (17c)$$

$$b \leq B \leq \sigma_3^2 \left( 1 + \text{SNR}_{31} + \text{SNR}_{32} + 2\rho\sqrt{\text{SNR}_{31}\text{SNR}_{32}} + 2\sqrt{\lambda_{1e}\text{SNR}_{31}\lambda_{2e}\text{SNR}_{31}} \right), \quad (17d)$$

where  $(\rho, \lambda_{ip}, \lambda_{ie}) \in [0, 1]^3$ , such that  $\rho + \lambda_{ip} + \lambda_{ie} \leq 1$ .

*Proof:* The sketch of proof of Theorem 1 is presented in the following section. ■

### B. Sketch of proof of Achievability

The achievability scheme presented in this section is built upon random coding arguments using rate-splitting [1], superposition coding, backward decoding [2], common randomness and power-splitting [3]. Let  $W_i^{(t)} \in \{1, 2, \dots, 2^{NR_i}\}$  and  $\Omega \in \{1, 2, \dots, 2^{NR_E}\}$  be the message index and the common random index at transmitter  $i$  during the  $t$ -th block. Following a rate-splitting argument, the index  $W_i^{(t)}$  is divided into two sub-indices  $W_{i,P}^{(t)} \in \{1, 2, \dots, 2^{NR_{i,P}}\}$  and  $W_{i,C}^{(t)} \in \{1, 2, \dots, 2^{NR_{i,C}}\}$ , where  $R_{i,C} + R_{i,P} = R_i$ . At the end of block  $t$ , the message indices  $W_{i,C}^{(t)}$  and  $W_{i,P}^{(t)}$  must be decoded by receiver  $i$ , whereas  $W_{i,C}^{(t)}$  must be decoded by receiver  $j$ , and by transmitter  $j$  via feedback. Therefore at the beginning of block  $t$ , each transmitter possesses the knowledge of the indices  $W_{1,C}^{(t-1)}$  and  $W_{2,C}^{(t-1)}$ . In the case of the first block  $t = 1$ , the indices  $W_{1,C}^{(0)}$  and  $W_{2,C}^{(0)}$  correspond to two indices assumed to be known by all transmitters and receivers. The codebook generation at transmitter  $i$  follows a four-level superposition coding scheme. The first-layer codebook is common and consists of  $2^{NR_E}$  codewords of length  $N$  symbols, denoted by  $\mathbf{v}(1), \mathbf{v}(2), \dots, \mathbf{v}([2^{NR_E}])$ . Note that both transmitters know  $\Omega$ , hence they are able to choose the same codeword  $\mathbf{v}(\Omega)$  from the first-layer codebook. The index  $\Omega$  as well as the codeword  $\mathbf{v}(\Omega)$  are also known at the receivers, which highlights that the role of this codebook is not information transmission but energy transmission. For each codeword in the first-layer codebook, transmitters possesses a sub-codebook of  $2^{N(R_{1,C}+R_{2,C})}$  codewords. The codewords superposed on codeword  $\mathbf{v}(\Omega)$  are denoted by  $\mathbf{u}(\Omega, 1, 1), \mathbf{u}(\Omega, 1, 2), \dots, \mathbf{u}(\Omega, [2^{NR_{1,C}}], [2^{NR_{2,C}}])$ . The resulting  $[2^{NR_E}] \cdot [2^{NR_{1,C}}] \cdot [2^{NR_{2,C}}]$  codewords are referred to as the second-layer codebook. For each codeword in the second-layer codebook there is a sub-codebook of  $2^{NR_{i,C}}$  codewords. The codewords superposed on codeword  $\mathbf{u}(\Omega, W_{1,C}^{(t-1)}, W_{2,C}^{(t-1)})$  are denoted by  $\mathbf{u}_i(\Omega, W_{1,C}^{(t-1)}, W_{2,C}^{(t-1)}, 1), \mathbf{u}_i(\Omega, W_{1,C}^{(t-1)}, W_{2,C}^{(t-1)}, 2), \dots, \mathbf{u}_i(\Omega, W_{1,C}^{(t-1)}, W_{2,C}^{(t-1)}, [2^{NR_{i,C}}])$ . The resulting  $[2^{NR_E}] \cdot [2^{NR_{1,C}}] \cdot [2^{NR_{2,C}}] \cdot [2^{NR_{i,C}}]$  codewords are referred to as the third-layer code. For each codeword in the third-layer codebook there is a sub-codebook of  $2^{NR_{i,P}}$  codewords. The codewords superposed on codeword  $\mathbf{u}_i(\Omega, W_{1,C}^{(t-1)}, W_{2,C}^{(t-1)}, W_{i,C}^{(t)})$

are denoted by  $\mathbf{s}_i(\Omega, W_{1,C}^{(t-1)}, W_{2,C}^{(t-1)}, W_{i,C}^{(t)}, 1), \mathbf{s}_i(\Omega, W_{1,C}^{(t-1)}, W_{2,C}^{(t-1)}, W_{i,C}^{(t)}, 2), \dots, \mathbf{s}_i(\Omega, W_{1,C}^{(t-1)}, W_{2,C}^{(t-1)}, W_{i,C}^{(t)}, [2^{NR_{i,P}}])$ . The resulting  $[2^{NR_E}] \cdot [2^{NR_{1,C}}] \cdot [2^{NR_{2,C}}] \cdot [2^{NR_{i,C}}] \cdot [2^{NR_{i,P}}]$  codewords are referred to as the four layer code. For transmitting the triplet  $(\Omega, W_{1,C}^{(t-1)}, W_{2,C}^{(t-1)}, W_{i,C}^{(t)}, W_{i,P}^{(t)})$ , the channel input-symbol  $X_{i,n}$  at channel use  $n \in \{1, 2, \dots, N\}$  is a deterministic function of the  $n$ -th components of the codewords  $\mathbf{v}(\Omega), \mathbf{u}(\Omega, W_{1,C}^{(t-1)}, W_{2,C}^{(t-1)}), \mathbf{u}_i(\Omega, W_{1,C}^{(t-1)}, W_{2,C}^{(t-1)}, W_{i,C}^{(t)})$  and  $\mathbf{s}_i(\Omega, W_{1,C}^{(t-1)}, W_{2,C}^{(t-1)}, W_{i,C}^{(t)}, W_{i,P}^{(t)})$ . The information rates  $(R_1, R_2)$  that are achievable by the code described above satisfy the following inequalities.

*Lemma 1:* The set of achievable information rate pairs  $(R_1, R_2)$  satisfies the following inequalities for all  $i \in \{1, 2\}$  and  $j \in \{1, 2\} \setminus \{i\}$ :

$$R_i \leq I(U, X_i, U_j; Y_i|V), \quad (18a)$$

$$R_i \leq I(U_i; Y_j|U, X_j, V) + I(X_i; Y_i|U_i, U_j, U, V), \quad (18b)$$

$$R_1 + R_2 \leq I(X_i; Y_i|U_i, U_j, U, V) + I(V, U_j, X_i; Y_i), \quad (18c)$$

for a given joint distribution  $P_{VUU_1U_2S_1S_2}(v, u, u_1, u_2, s_1, s_2)$  that factorizes as  $P_V(v) P_{U|V}(u|v) P_{U_1|UV}(u_1|uv) P_{U_2|UV}(u_2|uv) P_{S_1|UU_1V}(s_1|uu_1v) P_{S_2|UU_2V}(s_2|uu_2v)$  and  $X_i = \theta_i(V, U, U_i, S_i)$ , with  $\theta_1$  and  $\theta_2$  injective functions.

*Proof:* The proof of Lemma 1 uses standard arguments of weak typicality and is omitted in this paper. ■

For all  $k \in \{1, 2\}$  and a fixed tuple  $(\rho, \lambda_{kc}, \lambda_{kp}, \lambda_{ke}) \in [0, 1]^4$  such that  $\rho + \lambda_{kc} + \lambda_{kp} + \lambda_{ke} = 1$ , consider the following random variables:  $V \sim \mathcal{N}(0, 1)$ ;  $U \sim \mathcal{N}(0, \rho)$ ;  $U_k \sim \mathcal{N}(0, \lambda_{kc})$ ; and  $S_k \sim \mathcal{N}(0, \lambda_{kp})$ , which are independent of each other. Let the channel input of transmitter  $k$  be

$$X_k = \sqrt{P_k}U + \sqrt{P_k}S_k + \sqrt{P_k}U_k + \sqrt{\lambda_{ke}P_k}V. \quad (19)$$

The choice of this input distribution yields

$$I(U, X_i, U_j; Y_i|V) = \frac{1}{2} \log \left( \frac{1+(1-\lambda_{ie})\text{SNR}_i+(1-\lambda_{je})\text{INR}_i+2\rho\sqrt{\text{SNR}_i\text{INR}_i}}{1+\lambda_{jp}\text{INR}_i} \right), \quad (20a)$$

$$I(U_i, X_i, U_j; Y_i|V) = \frac{1}{2} \log \left( \frac{1+(1-(\rho+\lambda_{ie}))\text{INR}_j}{1+\lambda_{ip}\text{INR}_j} \right), \quad (20b)$$

$$I(X_i; Y_i|U, U_i, U_j, V) = \frac{1}{2} \log \left( \frac{1+\lambda_{ip}\text{SNR}_i+\lambda_{jp}\text{INR}_i}{1+\lambda_{jp}\text{INR}_i} \right). \quad (20c)$$

Finally, plugging (20) into (18) completes the proof of (17a) - (17c).

The average received energy rate  $\bar{B}$  achieved by using the

code described above is given by

$$\begin{aligned}\bar{B} &= E[Y_{3,n}^2] \\ &= h_{31}^2 E[X_{1,n}^2] + h_{32}^2 E[X_{2,n}^2] + 2h_{31}h_{32}E[X_{1,n}X_{2,n}] + \sigma_3^2 \\ &\leq h_{31}^2 P_1 + h_{32}^2 P_2 + 2|h_{31}||h_{32}|\sqrt{P_1 P_2}(\rho + \sqrt{\lambda_{1e}\lambda_{2e}}) + \sigma_3^2 \\ &= \sigma_3^2 \left( 1 + \text{SNR}_{31} + \text{SNR}_{32} \right. \\ &\quad \left. + 2\sqrt{\text{SNR}_{31}\text{SNR}_{32}}(\rho + \sqrt{\lambda_{1e}\lambda_{2e}}) \right).\end{aligned}$$

From the weak law of large numbers [4], it holds that  $\forall \epsilon > 0$ ,

$$\lim_{N \rightarrow \infty} \Pr \left( B^{(N)} < \bar{B} - \epsilon \right) = 0. \quad (21)$$

From (21), it holds that for any energy rate  $B$  that satisfies  $0 < B \leq \bar{B}$ , it holds that

$$\lim_{N \rightarrow \infty} \Pr \left( B^{(N)} < B - \epsilon \right) = 0, \quad (22)$$

which proves (17d) and completes the sketch of proof.

### C. Converse

The following theorem describes a converse region denoted by  $\bar{\mathcal{E}}_b^F$ .

*Theorem 2:* Let  $b$  be a fixed positive real. Then, the information-energy capacity region  $\mathcal{E}_b^F$  is contained into the set of all the rate tuples  $(R_1, R_2, B)$  that satisfy for all  $i \in \{1, 2\}$  and  $j \in \{1, 2\} \setminus \{i\}$ :

$$R_i \leq \frac{1}{2} \log \left( 1 + \beta_i \text{SNR}_i + \beta_j \text{INR}_i + 2\rho \sqrt{\beta_i \text{SNR}_i \beta_j \text{INR}_i} \right), \quad (23a)$$

$$\begin{aligned}R_i &\leq \frac{1}{2} \log \left( 1 + \frac{\beta_i(1 - \rho^2)\text{SNR}_i}{1 + \beta_i(1 - \rho^2)\text{INR}_j} \right) \\ &\quad + \frac{1}{2} \log \left( 1 + \beta_i(1 - \rho^2)\text{INR}_j \right),\end{aligned} \quad (23b)$$

$$\begin{aligned}R_1 + R_2 &\leq \frac{1}{2} \log \left( 1 + \frac{\beta_i(1 - \rho^2)\text{SNR}_i}{1 + \beta_i(1 - \rho^2)\text{INR}_j} \right) \\ &\quad + \frac{1}{2} \log \left( 1 + \beta_j \text{SNR}_j + \beta_i \text{INR}_j + 2\rho \sqrt{\beta_j \text{SNR}_j \beta_i \text{INR}_j} \right),\end{aligned} \quad (23c)$$

$$\begin{aligned}B &\leq 1 + \text{SNR}_{31} + \text{SNR}_{32} + 2\rho \sqrt{\beta_1 \text{SNR}_{31} \beta_2 \text{SNR}_{32}} \\ &\quad + 2\sqrt{(1 - \beta_1)\text{SNR}_{31}(1 - \beta_2)\text{SNR}_{32}},\end{aligned} \quad (23d)$$

with  $(\beta_1, \beta_2) \in [0, 1]^2$ .

*Proof:* The sketch of the proof of Theorem 2 is presented in the following section. ■

### D. Sketch of proof of the Converse

Fix an information-energy rate triplet  $(R_1, R_2, B)$  achievable with a given coding scheme (Definition 1). Denote by  $\mathbf{X}_1$  and  $\mathbf{X}_2$  the channel inputs resulting from transmitting the independent messages  $(W_1, \Omega)$  and  $(W_2, \Omega)$  using such coding scheme. Denote by  $\mathbf{Y}_1$  and  $\mathbf{Y}_2$  the corresponding channel outputs. Define the following random variables:

$$\begin{aligned}S_1 &= h_{21}X_1 + Z_2, \text{ and} \\ S_2 &= h_{12}X_2 + Z_1,\end{aligned}$$

where,  $Z_1$  and  $Z_2$  are real Gaussian random variables independent of each other with zero means and variances  $\sigma_1^2$  and  $\sigma_2^2$ , respectively. Using assumption (15) and Fano's inequality and following similar steps as in [2], it can be shown that the information rates  $R_1$  and  $R_2$  must satisfy the following inequalities for all  $i \in \{1, 2\}$  and  $j \in \{1, 2\} \setminus \{i\}$ :

$$NR_i \leq \sum_{n=1}^N [h(Y_{i,n}) - h(Z_{i,n})] + o(N), \quad (24a)$$

$$\begin{aligned}NR_i &\leq \sum_{n=1}^N [h(Y_{j,n})|X_{j,n} - h(Z_{j,n}) \\ &\quad + h(Y_{i,n}|X_{j,n}, S_{i,n}) - h(Z_{i,n})] + o(N),\end{aligned} \quad (24b)$$

$$\begin{aligned}N(R_1 + R_2) &\leq \sum_{n=1}^N [h(Y_{i,n}|S_{i,n}, X_{j,n}) \\ &\quad - h(Z_{i,n}) + h(Y_{j,n}) - h(Z_{j,n})] + o(N),\end{aligned} \quad (24c)$$

where  $\frac{o(N)}{N}$  tends to zero as  $N$  tends to infinity.

Using assumption (16), for a given  $\epsilon_N > 0$  and an  $\eta > 0$ , there exist  $N_0(\eta)$  such that for any  $N \geq N_0(\eta)$  it holds that

$$\Pr \left( B^{(N)} < B - \epsilon_N \right) < \eta. \quad (25)$$

Equivalently,

$$\Pr \left( B^{(N)} \geq B - \epsilon_N \right) \geq 1 - \eta. \quad (26)$$

From Markov's inequality, the following holds:

$$(B - \epsilon_N) \Pr \left( B^{(N)} \leq B - \epsilon_N \right) \leq E[B^{(N)}]. \quad (27)$$

Combining (26) and (27) yields

$$(B - \epsilon_N)(1 - \eta) \leq E[B^{(N)}], \quad (28)$$

which can be written as

$$(B - \delta_N) \leq E[B^{(N)}], \quad (29)$$

for some  $\delta_N > \epsilon_N$  and a sufficiently large  $N$ .

In the following, for all  $n \in \mathbb{N}$ , the bounds in (24) and (29) are evaluated assuming that the channel inputs  $X_{1,n}$  and  $X_{2,n}$  are arbitrary correlated random variables with

$$\mu_{i,n} \triangleq E[X_{i,n}], \quad (30)$$

$$\gamma_{i,n}^2 \triangleq \text{Var}[X_{i,n}], \quad (31)$$

$$\lambda_n \triangleq \text{Cov}[X_{1,n}, X_{2,n}]. \quad (32)$$

The input sequences must satisfy the input power constraint (4) which can be written for  $i \in \{1, 2\}$ , as

$$\frac{1}{N} \sum_{n=1}^N E[X_{i,n}^2] = \left( \frac{1}{N} \sum_{n=1}^N \gamma_{i,n}^2 \right) + \left( \frac{1}{N} \sum_{n=1}^N \mu_{i,n}^2 \right) \leq P_i. \quad (33)$$

Using these elements, the terms in the right-hand side of (24) can be upper-bounded as follows:

$$h(Y_{i,n}) \leq \frac{1}{2} \log_2 \left( 2\pi e (h_{ii}^2 \gamma_{i,n}^2 + h_{ij}^2 \gamma_{j,n}^2 + 2h_{ii}h_{ij}\lambda_n + \sigma_1^2) \right), \quad (34a)$$

$$h(Y_{j,n}|X_{j,n}) \leq \frac{1}{2} \log \left( 1 + \gamma_{i,n}^2 \left( 1 - \frac{\lambda_n^2}{\gamma_{i,n}^2 \gamma_{j,n}^2} \right) \frac{h_{ji}^2}{\sigma_j^2} \right) + \frac{1}{2} \log(2\pi e \sigma_j^2), \text{ and} \quad (34b)$$

$$h(Y_{i,n}|X_{j,n}, S_{i,n}) \leq \frac{1}{2} \log \left( 1 + \frac{\gamma_{i,n}^2 \left( 1 - \frac{\lambda_n^2}{\gamma_{i,n}^2 \gamma_{j,n}^2} \right) \frac{h_{ii}^2}{\sigma_i^2}}{1 + \gamma_{i,n}^2 \left( 1 - \frac{\lambda_n^2}{\gamma_{i,n}^2 \gamma_{j,n}^2} \right) \frac{h_{ji}^2}{\sigma_j^2}} \right) + \frac{1}{2} \log(2\pi e \sigma_i^2). \quad (34c)$$

The expectation of the average received energy rate is given by

$$\begin{aligned} \mathbb{E} [B^{(N)}] &= \mathbb{E} \left[ \frac{1}{N} \sum_{n=1}^N Y_{3,n}^2 \right] = \\ &h_{31}^2 \left( \frac{1}{N} \sum_{n=1}^N (\gamma_{1,n}^2 + \mu_{1,n}^2) \right) + h_{32}^2 \left( \frac{1}{N} \sum_{n=1}^N (\gamma_{2,n}^2 + \mu_{2,n}^2) \right) \\ &+ 2h_{31}h_{32} \left( \frac{1}{N} \sum_{n=1}^N (\lambda_n + \mu_{1,n}\mu_{2,n}) \right) + \sigma_3^2. \end{aligned} \quad (35)$$

Using Cauchy-Schwarz inequality, the energy rate in (35) can be upper-bounded as follows:

$$\begin{aligned} \mathbb{E} [B^{(N)}] &\leq \sigma_3^2 + h_{31}^2 \left( \frac{1}{N} \sum_{n=1}^N (\gamma_{1,n}^2 + \mu_{1,n}^2) \right) \\ &+ h_{32}^2 \left( \frac{1}{N} \sum_{n=1}^N (\gamma_{2,n}^2 + \mu_{2,n}^2) \right) \\ &+ 2h_{31}h_{32} \left( \left| \frac{1}{N} \sum_{n=1}^N \lambda_n \right| + \left( \frac{1}{N} \sum_{n=1}^N \mu_{1,n}^2 \right)^{1/2} \left( \frac{1}{N} \sum_{n=1}^N \mu_{2,n}^2 \right)^{1/2} \right). \end{aligned} \quad (36)$$

Combining (29) and (36) yields the following upper-bound on the energy rate  $B$ :

$$\begin{aligned} B &\leq \sigma_3^2 + \frac{h_{31}^2}{N} \sum_{n=1}^N (\gamma_{1,n}^2 + \mu_{1,n}^2) + \frac{h_{32}^2}{N} \sum_{n=1}^N (\gamma_{2,n}^2 + \mu_{2,n}^2) \\ &+ 2h_{31}h_{32} \left( \left| \frac{1}{N} \sum_{n=1}^N \lambda_n \right| + \left( \frac{1}{N} \sum_{n=1}^N \mu_{1,n}^2 \right)^{1/2} \left( \frac{1}{N} \sum_{n=1}^N \mu_{2,n}^2 \right)^{1/2} \right) \\ &+ \delta_N. \end{aligned} \quad (37)$$

Consider the following definitions, for all  $i \in \{1, 2\}$ :

$$\mu_i^2 \triangleq \frac{1}{N} \sum_{n=1}^N \mu_{i,n}^2, \quad (38a)$$

$$\gamma_i^2 \triangleq \frac{1}{N} \sum_{n=1}^N \gamma_{i,n}^2, \text{ and} \quad (38b)$$

$$\beta_i \triangleq \frac{\gamma_i^2}{P_i}. \quad (38c)$$

$$\rho \triangleq \left( \frac{1}{N} \sum_{n=1}^N \lambda_n \right). \quad (38d)$$

Plugging (34) in (24) and after some manipulations using the definitions in (38) yields:

$$R_i \leq \frac{1}{2} \log \left( \frac{h_{ii}^2 \gamma_i^2}{\sigma_i^2} + \frac{h_{ij}^2 \gamma_j^2}{\sigma_j^2} + 2\rho \sqrt{\frac{h_{ii}^2 h_{ij}^2 \gamma_i^2 \gamma_j^2}{\sigma_i^4}} \right), \quad (39a)$$

$$\begin{aligned} R_i &\leq \frac{1}{2} \log \left( 1 + \frac{h_{ji}^2 \gamma_i^2}{\sigma_j^2} (1 - \rho^2) \right) \\ &+ \frac{1}{2} \log \left( 1 + \frac{\gamma_i^2 (1 - \rho^2) \frac{h_{ii}^2}{\sigma_i^2}}{1 + \gamma_i^2 (1 - \rho^2) \frac{h_{ji}^2}{\sigma_j^2}} \right) \end{aligned} \quad (39b)$$

$$\begin{aligned} R_1 + R_2 &\leq \frac{1}{2} \log \left( \frac{h_{jj}^2 \gamma_j^2}{\sigma_j^2} + \frac{h_{ji}^2 \gamma_i^2}{\sigma_j^2} + 2\rho \sqrt{\frac{h_{jj}^2 h_{ji}^2 \gamma_i^2 \gamma_j^2}{\sigma_j^4}} \right) \\ &+ \frac{1}{2} \log \left( 1 + \frac{\gamma_i^2 (1 - \rho^2) \frac{h_{ii}^2}{\sigma_i^2}}{1 + \gamma_i^2 (1 - \rho^2) \frac{h_{ji}^2}{\sigma_j^2}} \right) \end{aligned} \quad (39c)$$

$$\begin{aligned} B &\leq \sigma_3^2 + h_{31}^2 (\gamma_1^2 + \mu_1^2) + h_{32}^2 (\gamma_2^2 + \mu_2^2) \\ &+ h_{32}^2 (\gamma_2^2 + \mu_2^2) + 2h_{31}h_{32} (|\rho| |\gamma_1| |\gamma_2| + |\mu_1| |\mu_2|), \quad (39d) \\ B &\geq b, \quad (39e) \end{aligned}$$

for some  $\gamma_1, \gamma_2, \mu_1^2$  and  $\mu_2^2$  that saturate the power constraint (33). Some trivial manipulations using the definitions of SNRs and INRs on (39) complete the sketch of proof.

### E. Approximation of the Information-Energy Capacity Region

Using the inner region  $\underline{\mathcal{E}}_b^F$  and the outer region  $\bar{\mathcal{E}}_b^F$ , described respectively by Theorem 1 and Theorem 2, the information-energy capacity region  $\mathcal{E}_b^F$  can be approximated in the sense of Definition 3.

*Theorem 3 (Approximation of  $\mathcal{E}_b^F$ ):* Let  $\underline{\mathcal{E}}_b^F \subset \mathbb{R}_+^3$  and  $\bar{\mathcal{E}}_b^F \subset \mathbb{R}_+^3$  be the sets of tuples  $(R_1, R_2, B)$  described by Theorem 1 and Theorem 2, respectively. Then,

$$\underline{\mathcal{E}}_b^F \subset \mathcal{E}_b^F \subset \bar{\mathcal{E}}_b^F, \quad (40)$$

and for all  $(R_1, R_2, B) \in \bar{\mathcal{E}}_b^F$  it follows that  $((R_1 - 2)^+, (R_2 - 2)^+, (B - \frac{B_{\max}}{2})^+) \in \underline{\mathcal{E}}_b^F$ .

*Proof:* Following similar steps as in [2], it can be shown that for all  $(R_1, R_2, 0) \in \bar{\mathcal{E}}_b^F$  it follows that  $((R_1 - 2)^+, (R_2 - 2)^+, 0) \in \underline{\mathcal{E}}_b^F$ . Note also that for all  $(R_1, R_2, B) \in \bar{\mathcal{E}}_b^F$

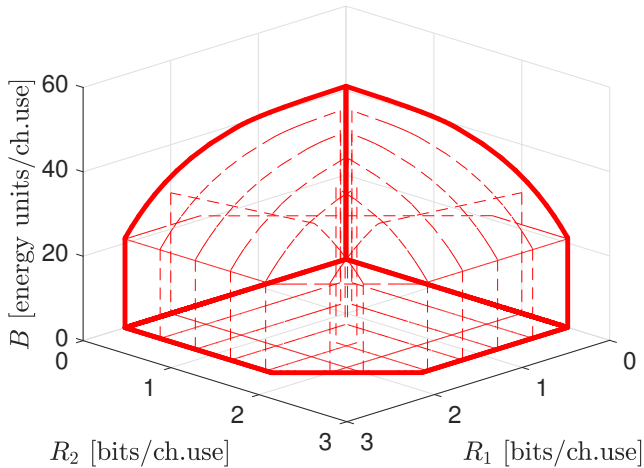

Fig. 2. 3-D representation of  $\mathcal{E}_b^F$ .

and for all  $(R_1, R_2, B') \in \mathcal{E}_b^F$ , there always exists a tuple  $(\beta_1, \beta_2, \lambda_{1e}, \lambda_{2e}, \rho)$  such that:

$$\begin{aligned}
 & \frac{B - B'}{B_{\max}} \\
 & \leq \frac{2|h_{31}||h_{32}|\sqrt{P_1P_2} \left( \sqrt{(1-\beta_1)(1-\beta_2)} + \rho\sqrt{\beta_1\beta_2} \right)}{\sigma_3^2 + h_{31}^2P_1 + h_{32}^2P_2 + 2|h_{31}||h_{32}|\sqrt{P_1P_2}} \\
 & \leq \frac{2\sqrt{\text{SNR}_{31}\text{SNR}_{32}}}{1 + \text{SNR}_{31} + \text{SNR}_{32} + 2\sqrt{\text{SNR}_{31}\text{SNR}_{32}}} \\
 & \leq \frac{2\sqrt{\text{SNR}_{31}\text{SNR}_{32}}}{1 + 4\sqrt{\text{SNR}_{31}\text{SNR}_{32}}} \\
 & \leq \frac{1}{2},
 \end{aligned}$$

which completes the proof.  $\blacksquare$

### III. EXAMPLE

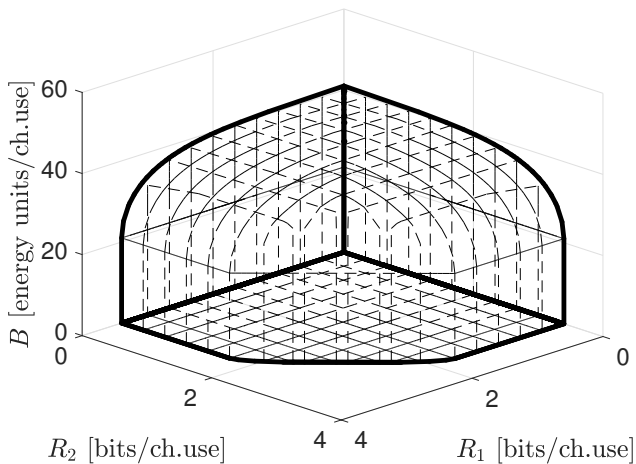

Fig. 3. 3-D representation of  $\bar{\mathcal{E}}_b^F$ .

Consider a Gaussian interference channel with feedback and an external EH with parameters  $\text{SNR}_1 = \text{SNR}_2 = 20$  dB,  $\text{INR}_1 = \text{INR}_2 = \text{SNR}_{31} = \text{SNR}_{32} = 10$  dB and  $\sigma_3^2 = 1$ . Figure 2 and Figure 3 show  $\mathcal{E}_b$  and  $\bar{\mathcal{E}}_b$ , respectively, with  $b = 0$ . Note that for all  $B \in [0, 1 + \text{SNR}_{31} + \text{SNR}_{32}]$ , transmitting information with independent codewords is enough to satisfy the energy rate constraints. This implies that  $\beta_1 = \beta_2 = 1$  is optimal in this regime. Alternatively, for all  $B \in [1 + \text{SNR}_{31} + \text{SNR}_{32}, B_{\max}]$ , transmitters deal with trade-off between the information and energy rate. Increasing  $B$  reduces the information region and makes the information-energy capacity region shrink.

### REFERENCES

- [1] T. S. Han and K. Kobayashi, "A new achievable rate region for the interference channel," *IEEE Transactions on Information Theory*, vol. 27, pp. 49–60, Jan. 1981.
- [2] C. Suh and D. N. C. Tse, "Feedback capacity of the Gaussian interference channel to within 2 bits," *IEEE Transactions on Information Theory*, vol. 57, pp. 2667–2685, May 2011.
- [3] S. Belhadj Amor, S. M. Perlaza, I. Krikidis, and H. V. Poor, "Feedback enhances simultaneous wireless information and energy transmission in multiple access channels," (To appear in) *IEEE Trans. Inf. Theory*, 2017.
- [4] R. Ash, *Information Theory*. New York, USA: Dover publications, Inc, 1990.