



HAL
open science

Alternatives to external polarization source for dielectric elastomer generators: electrets versus piezoelectric materials

Clara Lagomarsini, Giulia Lombardi, Claire Jean-Mistral, Alain Sylvestre

► To cite this version:

Clara Lagomarsini, Giulia Lombardi, Claire Jean-Mistral, Alain Sylvestre. Alternatives to external polarization source for dielectric elastomer generators: electrets versus piezoelectric materials. 7th international conference on Electromechanically Active Polymer (EAP) transducers & artificial muscles (EUROEAP2017), Jun 2017, Cartagène, Spain. hal-01551706

HAL Id: hal-01551706

<https://hal.science/hal-01551706>

Submitted on 30 Jun 2017

HAL is a multi-disciplinary open access archive for the deposit and dissemination of scientific research documents, whether they are published or not. The documents may come from teaching and research institutions in France or abroad, or from public or private research centers.

L'archive ouverte pluridisciplinaire **HAL**, est destinée au dépôt et à la diffusion de documents scientifiques de niveau recherche, publiés ou non, émanant des établissements d'enseignement et de recherche français ou étrangers, des laboratoires publics ou privés.

Poster ID:

2.3.4

Contact e-mail:
clara.lagomarsini@gmail.com

Alternatives to external polarization source for dielectric elastomers generators: electrets versus piezoelectric materials

Clara Lagomarsini⁽¹⁾, Giulia Lombardi⁽²⁾, Claire Jean-Mistral⁽³⁾, Alain Sylvestre⁽¹⁾

(1) Univ. Grenoble Alpes, CNRS, Grenoble INP, G2ELab, Grenoble, France; (2) Dept. Of Electrical, Electronic And Information Engineering, University Of Bologna, Italy; (3) Univ. Lyon, INSA Lyon, CNRS UMR 5259, LaMCoS, Villeurbanne, France

Abstract

Among the different technologies for kinetic energy harvesting, **dielectric elastomers generators (DEGs)** may represent a promising solution for supplying power to wearable low power consumption sensors and devices. These electrostatic generators provide a low-cost and lightweight solution to harvest high electrical energy densities from the mechanical deformation of an elastomeric membrane. The main disadvantage of these structures is the need of an external high voltage supply to perform the energetic cycle. In order to overcome this limitation and have a **completely autonomous energy scavenger**, our research group has been working since 2012, on coupling dielectric elastomers with electret materials (i.e. insulator materials that can hold a permanent electric charge over a long period of time). In the present work, a new hybrid solution for wearable energy harvesters based on DEG will be presented. This new autonomous device is based on the **combination of a DEG with a piezoelectric material**, which is used as new polarization source for the DEG energetic cycle. The working principle and the first results obtained on this new prototype are presented and a comparison between the two polarization solutions (electret and piezoelectric materials) is discussed.

State of the art

Classical DEGs: Working principle

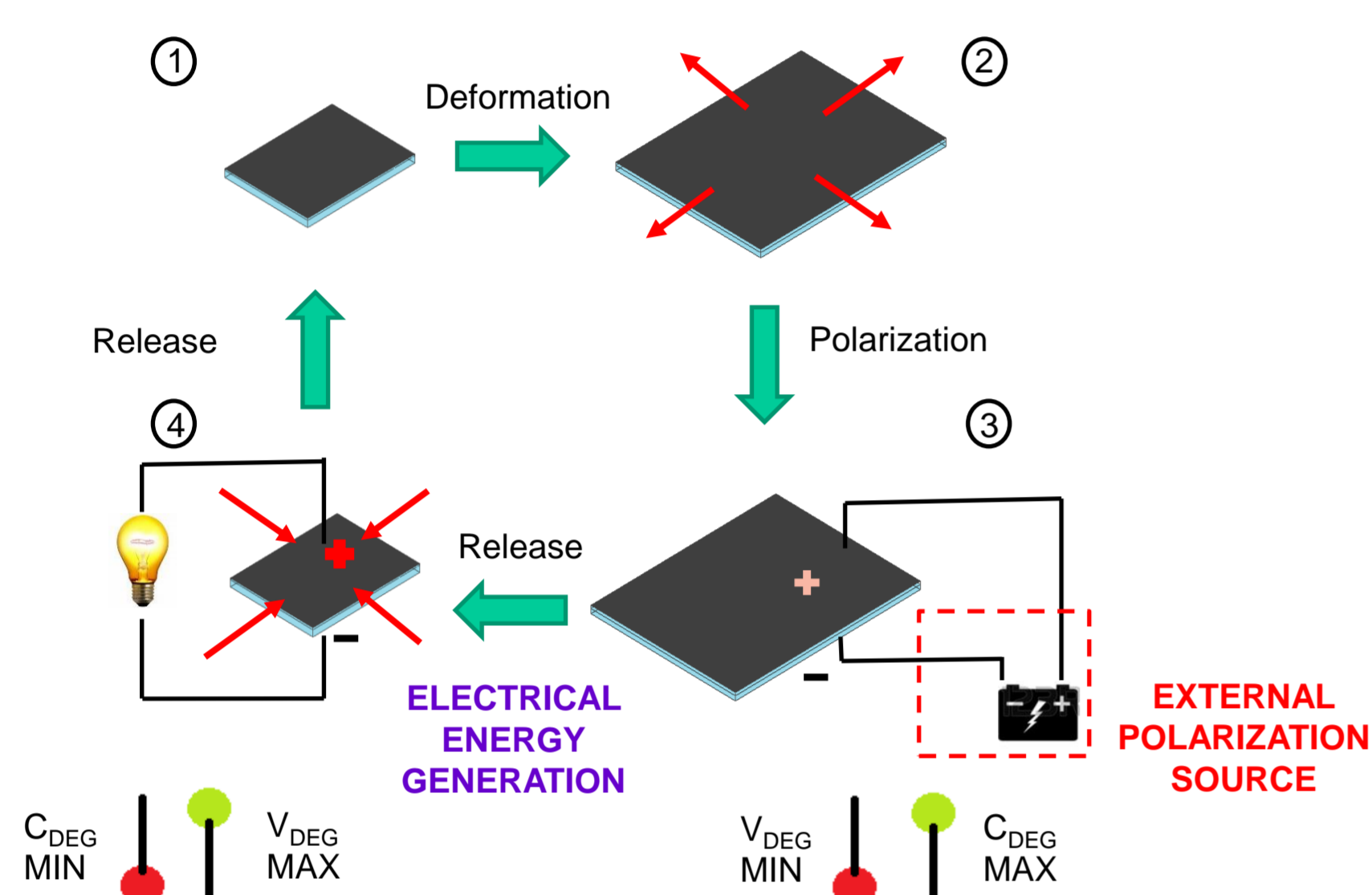

OBJECTIVE

Conceive fully autonomous DEG devices

ELECTRET materials (electric charges reservoirs) as DEG polarization source [1]

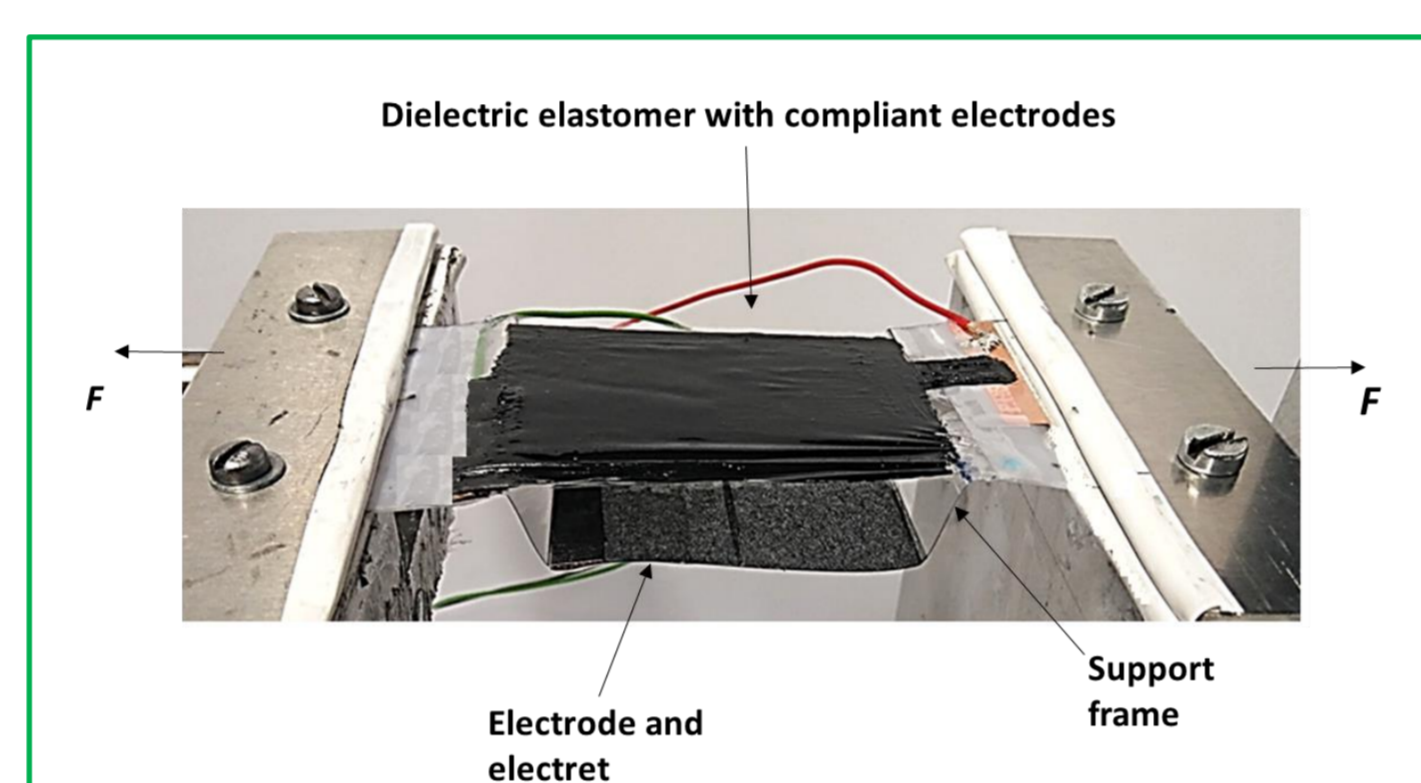

Experimental results

TESTING CONDITIONS:

- An uni-axial deformation λ equal to **50%** was imposed to the device with a mechanical test bench
- The deformation frequency was set to **1 Hz**, corresponding to the step frequency while walking

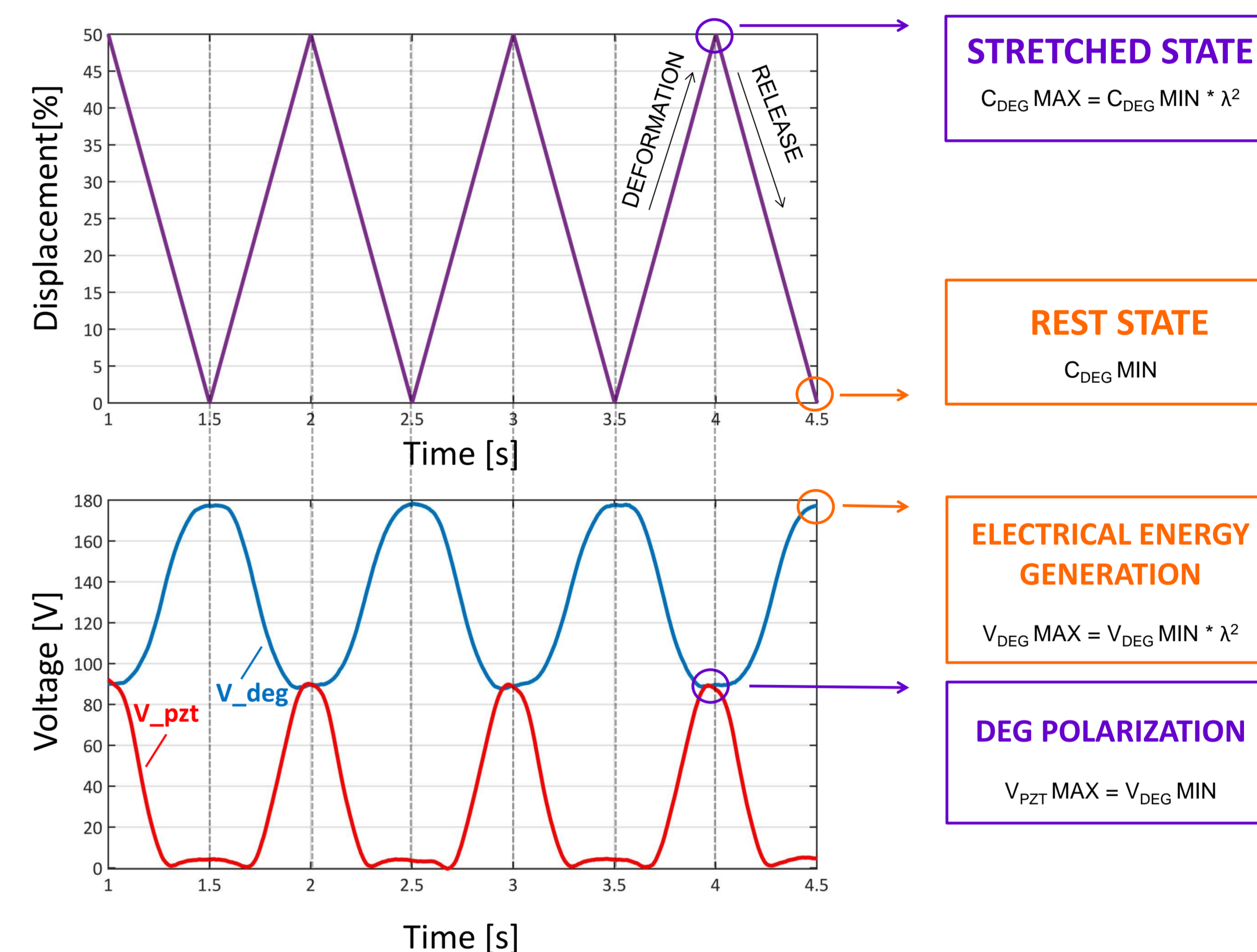

STRETCHED STATE
 $C_{DEG\ MAX} = C_{DEG\ MIN} \cdot \lambda^2$

REST STATE
 $C_{DEG\ MIN}$

ELECTRICAL ENERGY GENERATION
 $V_{DEG\ MAX} = V_{DEG\ MIN} \cdot \lambda^2$

DEG POLARIZATION
 $V_{PZT\ MAX} = V_{DEG\ MIN}$

New polarization source: PIEZOELECTRIC materials

- New **AUTONOMOUS hybrid device** based on a trapezoidal structure
- POLARIZATION SOURCE** for the DEG energetic cycle represented by a **PIEZOELECTRIC BUZZER** which is located in the lower part of the structure

REST STATE

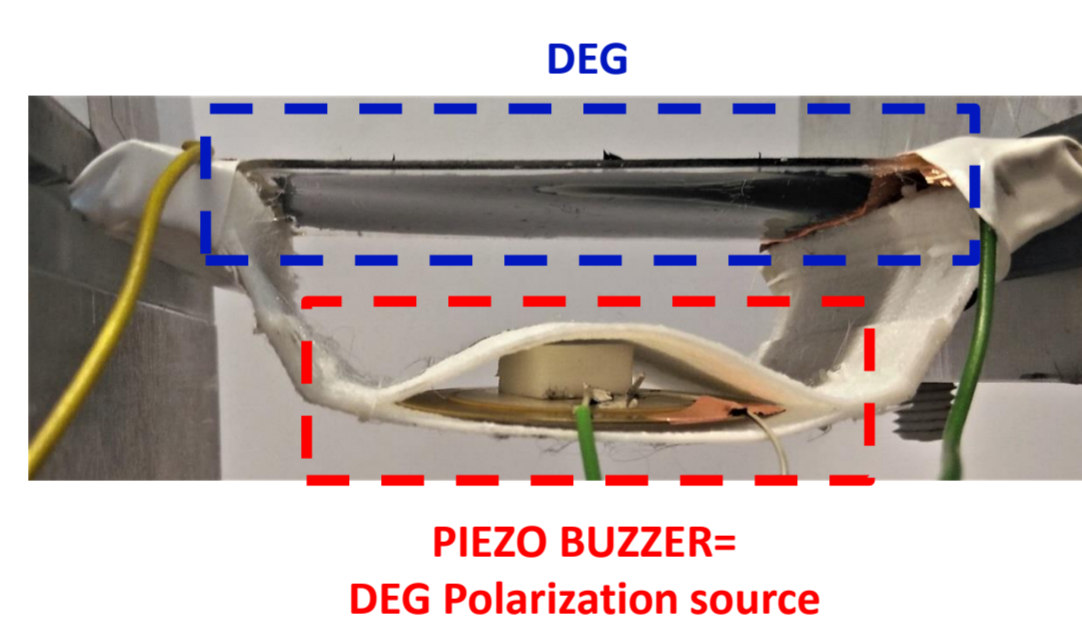
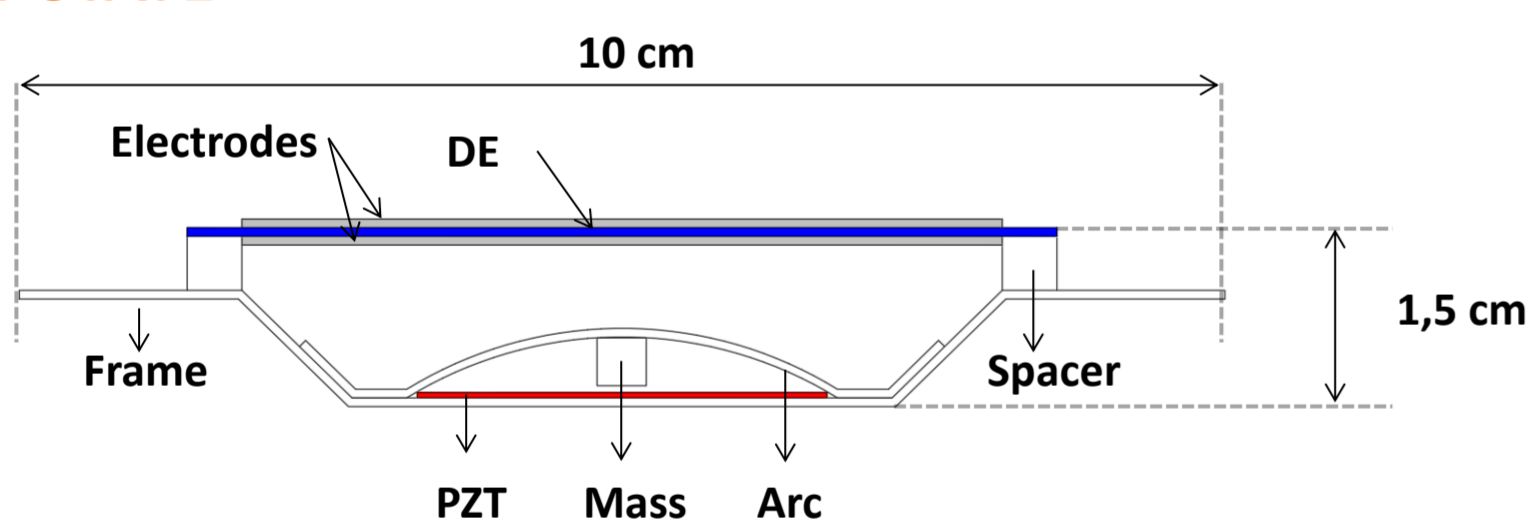

$C_{DEG\ MIN}$
 $V_{DEG\ MAX}$
 $V_{PZT\ MIN}$

STRETCHED STATE

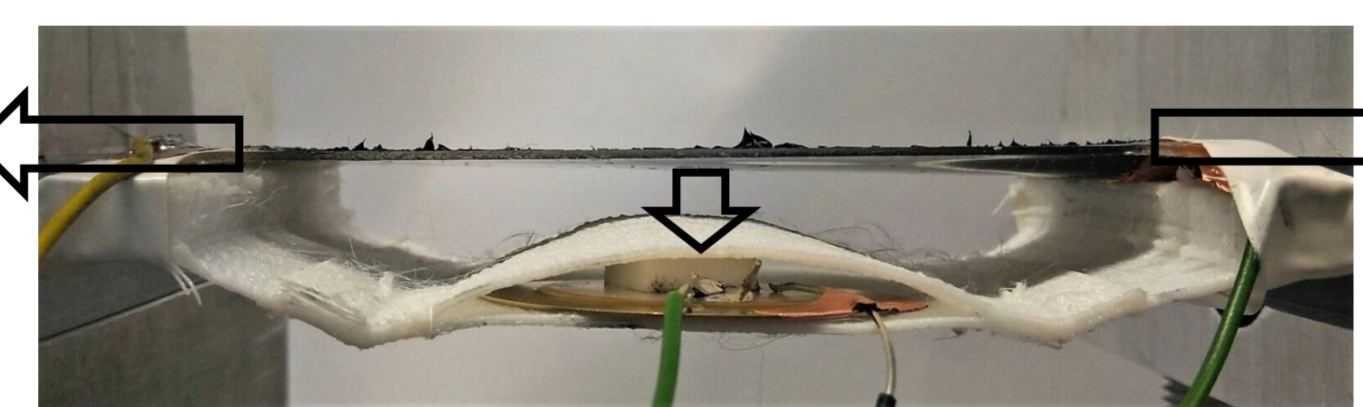
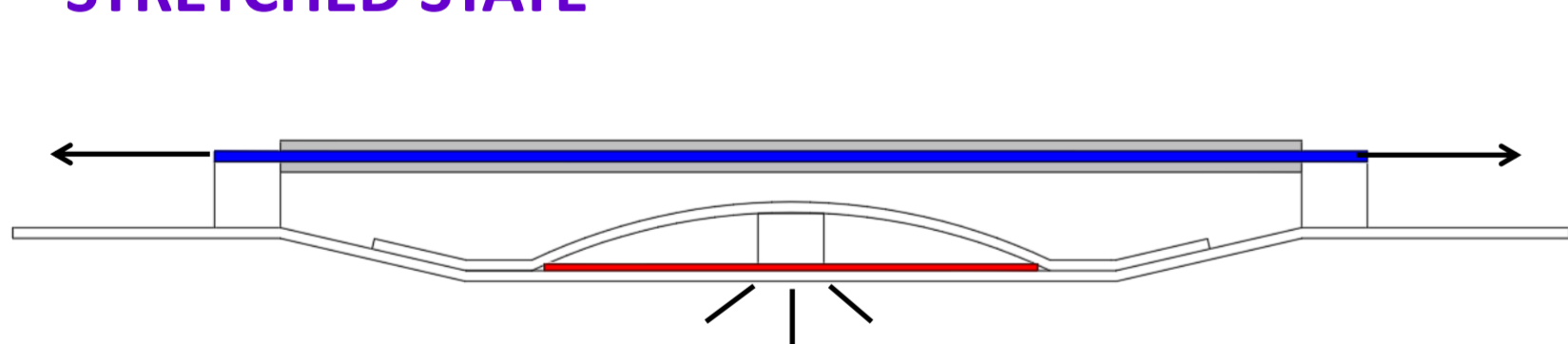

$C_{DEG\ MAX}$
 $V_{DEG\ MIN}$
 $V_{PZT\ MAX}$

ENERGY STORED on a CAPACITOR (1 nF): Comparison between the **piezoelectric** buzzer alone and the **hybrid PZT+DEG** device

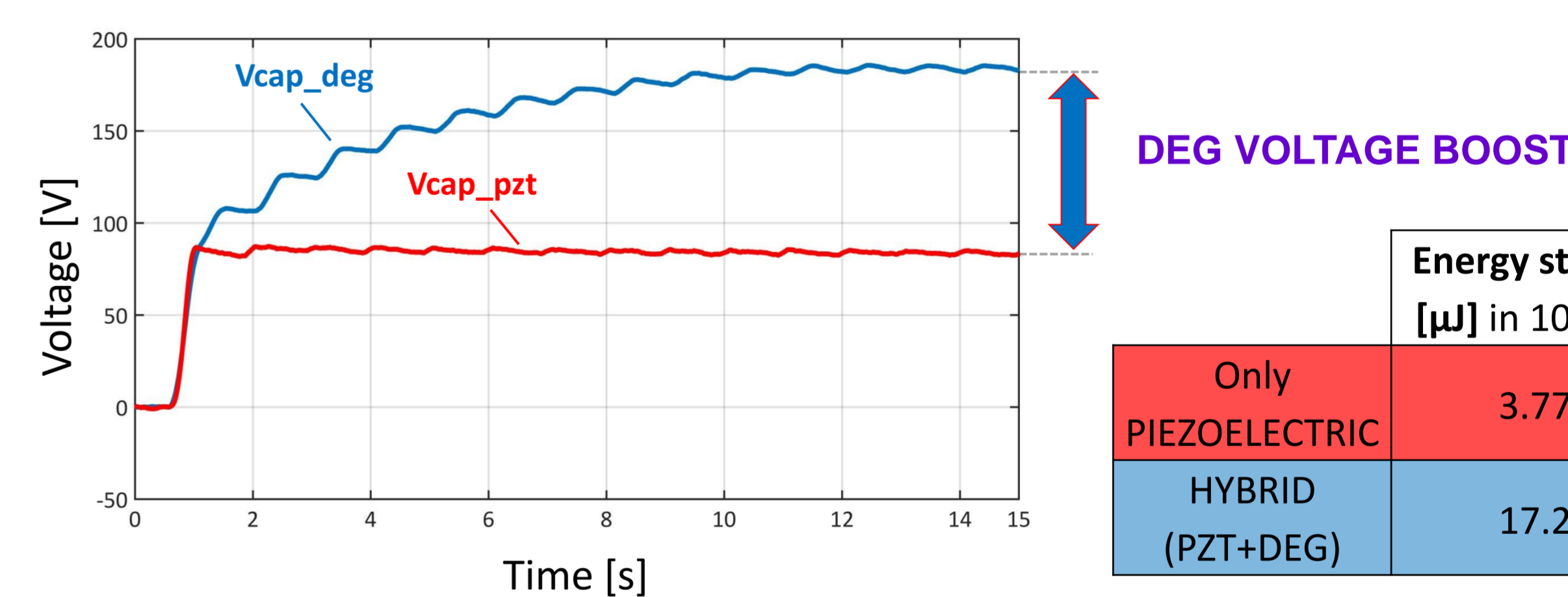

	Energy stored [μ J] in 10 sec.
Only PIEZOELECTRIC	3.77
HYBRID (PZT+DEG)	17.2

This value of energy represents the **FINAL useful energy** at the end of the energy harvesting cycle (Energy transduction + Power management unit)

Equivalent Circuits

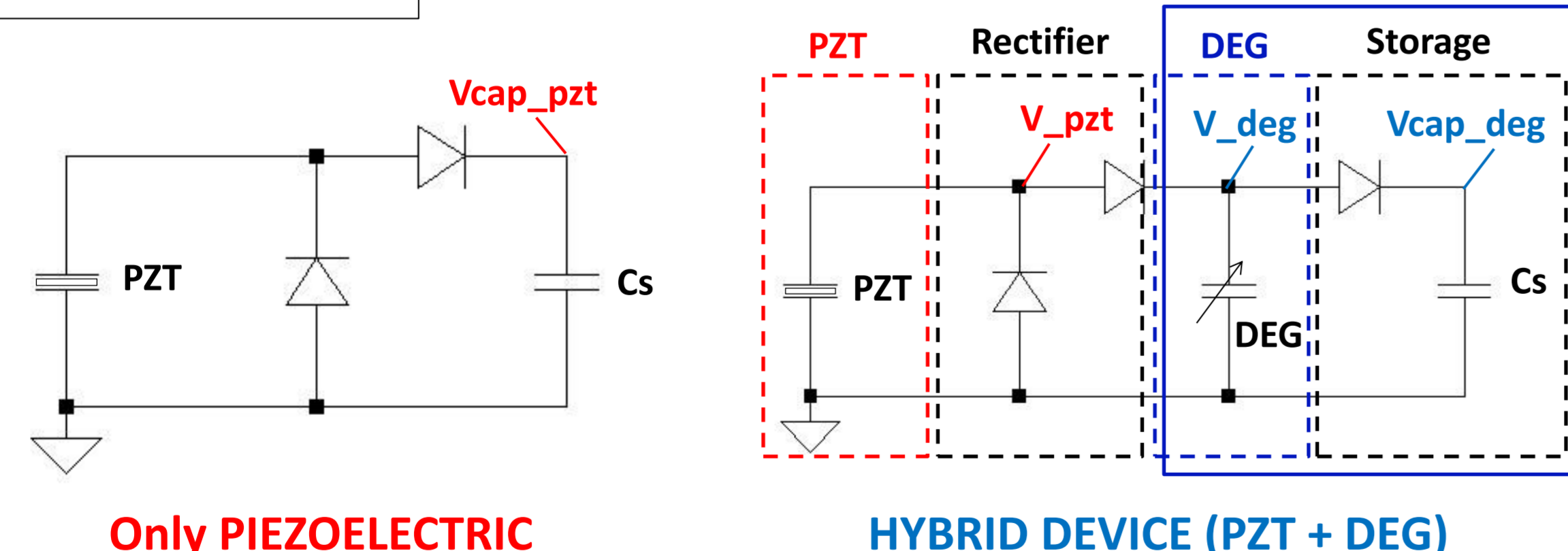

The voltage output generated by the compression force on the piezoelectric material is further boosted by the DEG energy cycle, thus **increasing the harvested energy output**

Governing DEG device EQUATIONS

CAPACITANCES (Uni-axial stretch)

$$C_{min} = \epsilon_0 \epsilon_r \frac{S_i}{d_i}$$

$$C_{max} = \epsilon_0 \epsilon_r \frac{S_f}{d_f} = \lambda^2 C_{min}$$

BOOSTED VOLTAGE (V_{max})

$$V_{max} = \frac{C_{max} V_{min}}{C_{min}} = \lambda^2 V_{min}$$

ENERGIES

$$E_{def_min} = \frac{1}{2} C_{min} V_{max}^2$$

$$E_{def_max} = \frac{1}{2} C_{max} V_{min}^2$$

$$E_{def_min} = \lambda^2 E_{def_max}$$

HARVESTED ENERGY (E_h)

$$E_h = E_{def_min} - E_{def_max} = E_{def_max} (\lambda^2 - 1)$$

Conclusions

Comparison between **ELECTRET** and **PIEZOELECTRIC** materials as polarization sources for autonomous DEG devices

	ELECTRET	PIEZOELECTRIC
POLARIZATION VOLTAGES	Depends on the final air gap value between the DEG and the electret material and on the surface potential of the electret	Depends on the deformation force acting on the piezoelectric element and on the number of buzzers used (stack configurations)
MAXIMAL POLARIZATION VALUES	Up to 210 V [1]	Up to 170 V (stack of 2 buzzers)
ADVANTAGES	<ul style="list-style-type: none"> Lightweight Simpler design 	Longer life-time
DISADVANTAGES	Sensitive to external environmental conditions	Higher encumbrance

Acknowledgments

Participation to this conference was partially supported by Région Rhône-Alpes (France) among the program "Communautés de Recherche Académique (ARC)" through grant No. 04, year 2014

References

[1] C. Lagomarsini et al. "New approach to improve the energy density of hybrid electret- dielectric elastomer generators", Proc. SPIE 10163, Electroactive Polymer Actuators and Devices (EAPAD) 2017, 101632C (April 17, 2017); doi:10.1117/12.2259933

QR CODE