



HAL
open science

Laminar Burning Velocities and Markstein Lengths of Jet Fuel Surrogate/Air Mixtures in a Spherical Chamber

Romain Le Dortz, Marc Bellenoue, Laurence Bonneau, Ekaterina Mazanchenko, Julien Sotton, Camille Strozzi

► **To cite this version:**

Romain Le Dortz, Marc Bellenoue, Laurence Bonneau, Ekaterina Mazanchenko, Julien Sotton, et al.. Laminar Burning Velocities and Markstein Lengths of Jet Fuel Surrogate/Air Mixtures in a Spherical Chamber. 8th european combustion meeting, Apr 2017, Dubrovnik, Croatia. hal-01537768

HAL Id: hal-01537768

<https://hal.science/hal-01537768>

Submitted on 12 Jun 2017

HAL is a multi-disciplinary open access archive for the deposit and dissemination of scientific research documents, whether they are published or not. The documents may come from teaching and research institutions in France or abroad, or from public or private research centers.

L'archive ouverte pluridisciplinaire **HAL**, est destinée au dépôt et à la diffusion de documents scientifiques de niveau recherche, publiés ou non, émanant des établissements d'enseignement et de recherche français ou étrangers, des laboratoires publics ou privés.

Laminar Burning Velocities and Markstein Lengths of Jet Fuel Surrogate/Air Mixtures in a Spherical Chamber

R. Le Dortz^{1,2,*}, M. Bellenoue², L. Bonneau³, E. Mazanchenko², J. Sotton², C. Strozzi³

¹ Safran Tech, Safran R&T Center, CS 80112, 78722 Magny-Les-Hameaux, France

² Institut Pprime, CNRS, ISAE-ENSMA, Université de Poitiers, F-86962 Futuroscope Chasseneuil, France

³ Institut Pprime, CNRS, Université de Poitiers, ISAE-ENSMA, F-86962 Futuroscope Chasseneuil, France

Abstract

Characterizing the propagation of jet fuel/air premixed flames during combustion is key to understanding the performances of advanced modes of combustion for turbo-engines. Consequently, a better knowledge of the combustion characteristics is necessary. Particularly, the laminar burning velocity and the Markstein length in laminar adiabatic conditions are both key parameters to improve the efficiency of innovated turbo-engines with technological breakthrough as constant-volume combustion. In the current study, a spherical combustion chamber equipped with various metrology systems is qualified. First, the new experimental set-up is validated with methane/air premixed laminar flames at normal temperature and pressure. The laminar burning velocity of four jet fuel surrogates is then characterized. Measurements are performed over a range of equivalence ratios from 0.7 to 1.5, initial temperature of 400 K, and initial pressure of 0.1 MPa. The results are compared with experimental data available in the literature and with calculations using the chemical kinetics code CANTERA (1D model) and existing chemical kinetic mechanisms. A comparison between the different surrogates is then discussed.

1. Introduction

Environmental impact is actually a major issue in aircraft design, especially reducing pollutant emission and fuel consumption which represents approximately 2 % of global consumption [1]. International bodies as ACARE (Advisory Council for Aviation Research and Innovation in Europe) suggest drastic objectives: a 75 % decrease in CO₂ emissions and a 90 % decrease in NO_x emissions before 2050 relative to the characteristics of aircrafts produced in 2000 [2]. These objectives are difficult to achieve with current turbo-engines which already have a very significant degree of maturity. Therefore innovative solutions with technological breakthrough are studied as constant-volume combustion, which could provide a remarkable 10 % to 20 % consumption reduction in comparison to current engines [3]. Designing new types of combustors with low consumption and low pollution is a key point for future turbo-engines. To reach these objectives, a better understanding, characterization and control of combustion process for kerosene is necessary. Though kerosene has been extensively used for decades in turbo-engines, still little is known on its basic premixed combustion properties, especially for the propagation of the premixed flame front. The knowledge of premixed flame propagation in laminar adiabatic conditions is an essential piece of data of jet fuels, but only recent and few relevant publications can be found concerning the laminar burning velocity and its dependence to flame stretch involving the Markstein length [4]. Both parameters depend on the chemical composition, pressure and temperature of fuel-air-diluent mixtures, and must be investigated in view to offer a comprehensive characterization of the operation

domain of constant-volume combustion chamber. Experimental database of laminar burning speeds are also needed to validate detailed kinetic chemical mechanisms representing combustion of kerosene.

Use of real kerosene fuels - for example, Jet A, JP-8 - involves a major problem: they are made up of hundreds of components and their compositions vary over time or according to their place of production [5]. Low stability over time must also be considered. In order to avoid this problem and for having repeatable experiments, laminar flame speeds measurements were carried out with surrogates representative of kerosene. Surrogates composed with 1 to 4 hydrocarbons are chosen to ensure an accurate control of its composition. This also facilitates the development of the related chemical kinetics mechanisms.

A wide range of multi-component surrogates was tested over the last decades to emulate jet fuel combustion properties. The reader is referred to Dagaut and Cathonnet [6] for a detailed review related to kerosene surrogates up to 2006, from both the numerical and experimental point of view. Other jet fuel surrogates were developed later with prospect to reproduce kerosene thermo-physical properties. Some studies also focus on combustion properties. Skeletal kinetic mechanisms were sometimes developed concurrently with the elaboration of the surrogate [14, 15]. Most of the time, the surrogates try to emulate JET-A POSF-4658, a reference blend of different commercial kerosene.

2. Specific Objectives

The present study focuses on measuring the laminar burning velocities and the Markstein lengths

* Corresponding author: romain.le-dortz@ensma.fr

for the following selected jet fuel multi-components surrogates: *n*-decane, the Aachen surrogate [9] (*n*-decane/1,2,4-trimethylbenzene 80/20 in mass%), the Dagaut surrogate [16] (*n*-decane/*n*-propylbenzene/*n*-propylcyclohexane 76.8/ 13.1/10.1 in mass%), and the MURI2 surrogate [12] (*n*-dodecane/isooctane/1,3,5-trimethylbenzene/*n*-propylbenzene 49.6/24.3/19.8/6.3 in mass%). The latter and recent one was specifically developed to best represent the chemical and physical properties of JET-A POSF-4658 kerosene. Measurements are made at normal pressure $P_0 = 0.1$ MPa, initial temperature $T_0 = 400$ K, and equivalence ratios range 0.7-1.5. Calculations are also performed with chemical kinetic mechanisms available in the literature for the different employed surrogates. A comparison between measurements, experimental data available in literature, and numerical predictions is discussed. An analysis of the comparison of the tested surrogates is also discussed. Indeed, the surrogates tend to be more and more complex, and the question about utility of this complexity is here raised.

3. Experimental and Numerical Methods

3.1. Spherical bomb

The combustion chamber is a stainless-steel spherical bomb with an inner volume of 4.2 L. The vessel is fitted with two UV-sapphire windows (70 mm optical diameter) to ensure optical diagnostics. The bomb is designed to support initial pressures reaching up to 1 MPa and initial temperatures up to 470 K heated by twenty-four cartridges heaters, and regulated with four K-thermocouples. Electrical discharges with electrical energies of approximately 20 mJ are deposited between two pin-to-pin tungsten electrodes (1 mm in diameter, gap set to 1 mm) by an inductive circuit. During combustion process, two diagnostics are employed and synchronized thanks to a TTL signal: pressure variations are measured using a piezoelectric dynamic pressure transducer Kistler 6054AR 0-250 bar protected with a silicone layer of 2 mm, coupled to a Kistler ICAM 5073A amplifier. A recording of the flame propagation is obtained simultaneously using a Schlieren optical system constituted with a high speed camera Photron FASTCAM SA5 (frame recording rate of 7 kHz) and a collimated LED as a light source. The resolution of the frame is 1,024*1,024 pixel².

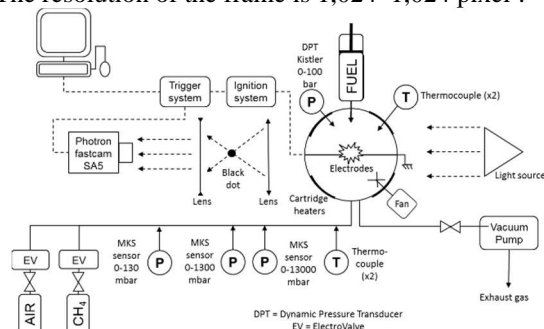

Fig.1. Experimental set-up.

3.2. Mixtures preparation and liquid fuel vaporization

The bomb is filled using the partial pressure method introducing directly the gases and the liquid fuels inside the combustion chamber. The procedure is the following: the vessel is first flushed with air, and then placed under vacuum. Liquid fuels are then injected, using a low-pressure automotive injector. At last, gases are admitted using two injections lines. Partial pressure of the fuels are measured by three absolute pressure transducers MKS Baratron Type 631 calibrated with different full scales depending to the desired pressure (0-100 torr, 0-1,000 torr and 0-10,000 torr). An uncertainty lower than 1.5 % is obtained for the determination of the equivalence ratio.

High-purity grade commercial chemicals are involved in the preparation of the fuel-air mixtures: methane (N45), *n*-decane (Merck, ≥ 99 %), *n*-dodecane (Merck, ≥ 99 %), *n*-propylbenzene (Merck, ≥ 98 %), 1,2,4-trimethylbenzene (Merck, ≥ 98 %), 1,3,5-trimethylbenzene (ACROS Organics, ≥ 98.5 %), isooctane anhydrous (Sigma-Aldrich, ≥ 99.75 %) and *n*-propylcyclohexane (Sigma-Aldrich, ≥ 98.5 %). Mixtures are completed with synthetic air realized with high purity oxygen and nitrogen (both 99.99 % pure) with molar ratio of $N_2:O_2 = 3.76$.

The preparation of the mixtures has to be realized very carefully because a difference between expected and real conditions in temperature, pressure and equivalence ratio, however small, can skew the results [17-18]. In particular, the accuracy of the results presented below depends on the ability to vaporize the liquid fuels and determine equivalence ratio accurately. To prevent condensation phenomenon of fuel in the chamber, the partial pressures of each fuel present in the mixtures have to be lower than their low-vapor pressure. The saturation vapor pressure of the chemical used in this study, excepted *n*-propylcyclohexane, were determined experimentally in Fig.2, and compared with their theoretical evolutions from Antoine equation [19]:

$$\log P = A - \frac{B}{T + C} \quad (1)$$

where P is the pressure, T the temperature, and A , B and C the Antoine coefficients.

Measurements are performed with an absolute pressure transducers MKS Baratron Type 631 0-1,000 torr into a tank with an inner volume of 302 cm³, equipped with a thermal control system.

Fig.2 shows *n*-dodecane being the component with the lowest vapor pressure. Isooctane the component with the higher vapor pressure: it is the most volatile component. Other components have a similar saturation pressure. In order to ensure an identical fuel mixture composition in both the liquid and gas phase, it has to be checked all the components are fully vaporized. In this respect, the limiting component in terms of vapor pressure is the *n*-dodecane: the saturation pressure of this component at

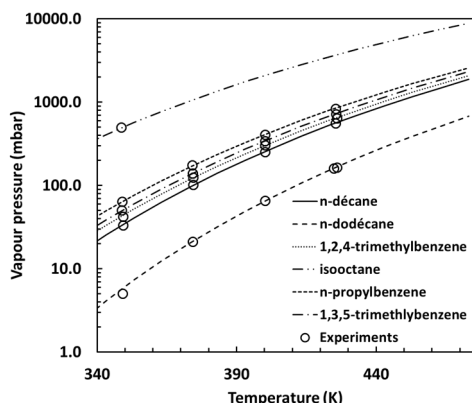

Fig.2. Saturation curves for hydrocarbons used in jet fuel surrogates. Symbols: experimental data; Lines: theoretical results.

an initial temperature $T_0 = 400$ K is $P_{\text{sat}} = 65$ mbar. Under these considerations and to prevent condensation, the main part of our study will take place, for an initial temperature $T_0 = 400$ K, and an initial pressure $P_0 = 0.1$ MPa.

3.3. Post-processing

The Schlieren images are post-processed with a Matlab program in order to determinate the time-evolution of the flame radius. The unstretched laminar burning velocity of the burnt gases S_b^0 and the Markstein length \mathcal{E}_b are extrapolated from the propagation speeds S_b and the stretch rates κ , obtained from this time-evolution of the flame radius (second order centered scheme), and using the non-linear model of Kelley and Law [20]:

$$\left(\frac{S_b}{S_b^0}\right)^2 \cdot \ln\left(\frac{S_b}{S_b^0}\right)^2 = -\frac{2\mathcal{E}_b\kappa}{S_b^0} \quad (2)$$

The unstretched laminar burning velocity S_u^0 and the unburnt Markstein length \mathcal{E}_{u0} are then evaluated by dividing S_b^0 by the ratio of the burnt gas to the unburnt gas densities ρ_u/ρ_b . The densities are calculated for an adiabatic combustion with the help of CANTERA chemical kinetic software [21] and thermodynamics data of the different components. The extrapolation is performed only using frames without cell detectable on flame front. The formation of cells is due to hydrodynamics and thermodiffusive effects, and generates an acceleration of the flame front [22]. Considering the extrapolation method, maximum uncertainties of the measurements are estimated at around 4 cm/s for higher laminar burning velocities, and around 0.15 mm for unburnt Markstein lengths.

Markstein length is relatively easy to determine with spherical expanding flames, even if a good accuracy is hard to obtain. This parameter represents the flame response to stretch and provides information on the flame stability. Markstein length is closely related to thermodiffusive effects and a negative value will favour these instabilities.

3.4. Computational methods

Numerical simulations of laminar burning velocities are performed using the chemical kinetic software CANTERA [21] and one-dimensional flame calculations of freely propagating unstretched laminar flames. Simulations are carried out with different kinetic mechanisms available in literature.

To compute the unstretched laminar flame speeds of methane-air premixed flame, GRI-Mech 3.0 mechanism is used [23]. This detailed mechanism was developed at Gas Research Institute in USA, and contains 53 species for 325 reactions. This mechanism was actively tested and optimized for methane as a fuel against many targets (species profiles, ignition delay, laminar flame speed...).

The case of *n*-decane is simulated with the JetSurF2.0 kinetic mechanism [15] developed through a multi-university research collaboration and funded by the Air Force Office of Scientific Research. It consists of 348 species and 2163 reactions. It was also actively tested and optimized for *n*-alkanes up to *n*-dodecane and mono-alkylated cyclohexanes. *n*-Decane is also computed with the Chang mechanism [24], constituted with 40 species and 141 reactions and also extensively validated under engine-relevant conditions.

Dagaut surrogate is modelled by the Luche reduced skeletal kinetic mechanism [14], derived from the El-Bakali detailed mechanism and developed at University of Orléans. The reduced mechanism consists of 91 species and 991 reactions, and was validated in a perfectly-stirred reaction simulation for a large panel of temperatures, pressures and equivalence ratios.

Aachen surrogate is described with the Honnet et al. chemical mechanism [9], and assembled from validated chemical mechanisms of its components. The Honnet et al. mechanism comprises 122 species for 900 reactions. It was validated to predict combustion of kerosene using shock tubes, rapid compression machine, jet-stirred reactions, burner stabilized premixed flames and freely propagation premixed flames experimental data.

3.5. Validation with methane-air mixtures

First measurements of laminar burning velocities are performed with methane-air premixed flames. The objective is to validate the experimental procedure comparing with previous data from literature employing the same experimental technique (spherical flames and non-linear model of Kelley and Law). The experiments were carried out at normal pressure and temperature for an equivalence ratios range of 0.7-1.3. Results of laminar burning velocities are presented in Fig.3. A good agreement is observed for the measurements in comparison with those of Halter et al. [25], Varea et al. [26] and Beeckman et al. [18], especially for lower equivalence ratios. Average differences of 1.9 % and 3.1 % are observed on the lean side, and 7 % and 13.9 % on the rich side,

respectively in comparison with the results of Halter et al. and Varea et al.. Therefore the experimental set-up is considered as validated. The GRI-Mech 3.0 mechanism succeeds to represent the laminar burning velocities correctly, although a slight underestimation of the targets values in the lean side. Differences between measurements and calculations are evaluated at 6.4 % and 4.7 % respectively on the lean and the rich side.

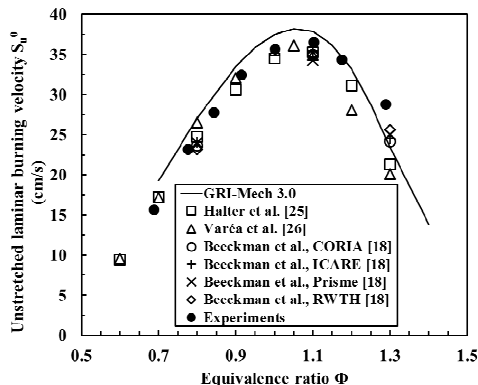

Fig.3. Unstretched laminar burning velocity S_u^0 plotted against equivalence ratio ϕ for a methane-air mixture at normal temperature and pressure.

4. Results and Discussion

Different jet fuel surrogates are tested in this study: *n*-decane, Aachen surrogate, Dagaut surrogate and MURI2 surrogate. Experimental measurements and calculations are presented in the following subsections, and are performed over a large range of equivalence ratios from 0.6 to 1.5, at initial temperature $T_0 = 400$ K and initial pressure $P_0 = 0.1$ MPa.

4.1. *n*-decane-air flames

Fig.4 shows the results of laminar burning velocities for a *n*-decane-air mixture. Typical trend of hydrocarbons fuels is observed: the unstretched laminar flame speed is maximum for a slightly rich mixture ($\phi \approx 1.09$) and decreases for smaller and higher equivalence ratios. These results are in excellent agreement with existing data of literature [27, 28] employing spherical flames and laminar flame speeds extrapolated with the non-linear model of Kelley and Law. Indeed, average differences of only 0.7 % and 2.6 % are observed in comparison to the results of Comandini et al., respectively on the lean and the rich side. JetSurf2.0 kinetic mechanism calculations are able to reproduce correctly the measurements, unlike the Chang mechanism which largely over-predicts the maximum flame speed, with a poor estimate of the corresponding optimum equivalence ratio.

Concerning Markstein lengths, a decrease is observed with increasing equivalence ratios for the *n*-decane-air mixture in Fig.5. The flame becomes unstable for an equivalence ratio $\phi \approx 1.30$. Beyond this value, wrinkles are favoured and created on the flame edge. Measurements are in very good agreement with

the data of literature. Especially, Comandini et al. have obtained a similar trend for the evolution of Markstein length against equivalence ratio, with a same transition of stable flame to unstable flame. It is worth noticing the results obtained for both flame velocity and Markstein length confirm the validity of the present experimental set-up and of the related procedures.

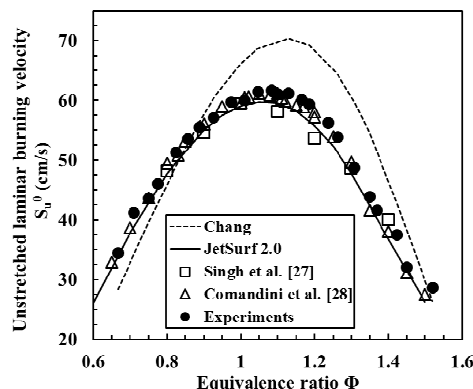

Fig.4. Unstretched laminar burning velocity S_u^0 plotted against equivalence ratio ϕ for a *n*-decane-air premixed flame at $T_0 = 400$ K and $P_0 = 0.1$ MPa.

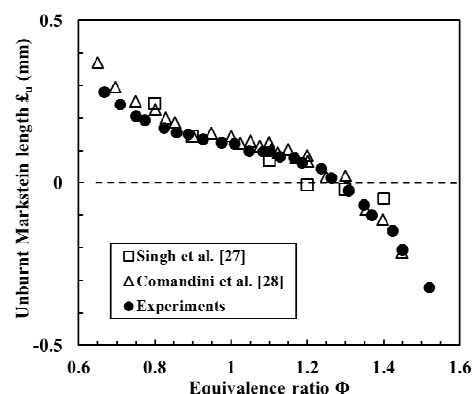

Fig.5. Unburnt Markstein length L_u plotted against equivalence ratio ϕ for a *n*-decane-air premixed flame at $T_0 = 400$ K and $P_0 = 0.1$ MPa.

4.2. Aachen surrogate

Measurements for laminar burning velocity of Aachen surrogate (*n*-decane/1,2,4-trimethylbenzene 80/20 in mass%) premixed with air are presented in Fig.6. The same typical similar trend is still observed with a maximum flame speed of 58.7 cm/s reached for the optimum equivalence ratio of 1.18. To the knowledge of the authors, there is no other experimental data for laminar burning velocity to compare with. On the other hand, Fig.6 reports a comparison with the calculations obtained with the kinetic mechanism developed by Honnet et al.. This mechanism was not validated for premixed flames and it is interesting to analyse if this mechanism is able to reproduce the laminar burning velocity of this surrogate. Calculations significantly over-estimate by 13 % the maximum flame speed. The optimum equivalence ratio is quite well evaluated.

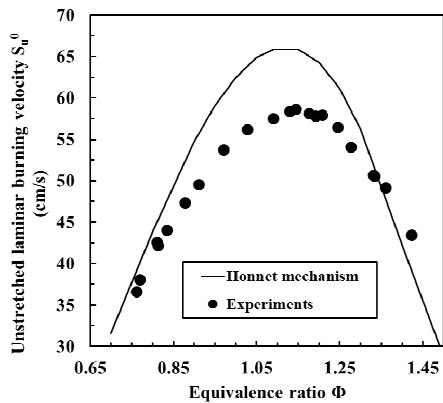

Fig.6. Unstretched laminar burning velocity S_u^0 plotted against equivalence ratio ϕ for an Aachen-air premixed flame at $T_0 = 400$ K and $P_0 = 0.1$ MPa.

4.3. Dagaut surrogate

Experimental results of the Dagaut surrogate (*n*-decane/*n*-propylbenzene/*n*-propylcyclohexane 76.8/13.1/10.1 in mass%) are shown in Fig.7. The measurements have a good correlation with the recent experimental data of Wu et al. [29] obtained with a Bunsen burner. Lean side equivalence ratios is very well reproduced with an average difference of only 2.1 % between our measurements and those of Wu et al.. An agreement is also observed on the rich side with an average difference of 7.5 %. Wu et al. experimental measurements are lower than ours. It can be explained by the fact that Wu et al. have employed more diluted air (N_2/O_2 volume ratio of 80/20) than this study.

Measurements are also well-represented by the reduced kinetic-chemical mechanism of Luche. It is able to reproduce laminar burning velocities with a good accuracy. Maximum differences on the average of 3.5 % and 6 % are obtained respectively on the lean and the rich side. The Luche reduced kinetic mechanism, already validated for modelling molar fractions profiles in perfectly stirred reactor and ignition delays in shock tubes, can be also now considered as validated for laminar burning velocities.

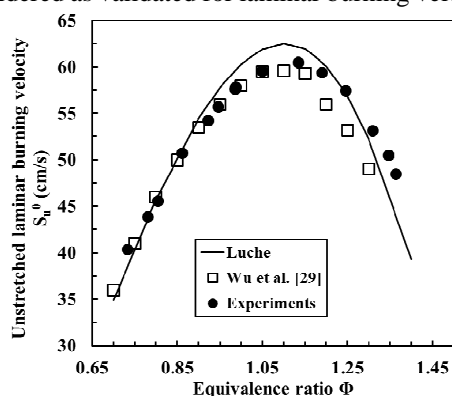

Fig.7. Unstretched laminar burning velocity S_u^0 plotted against equivalence ratio ϕ for a Dagaut-air premixed flame at $T_0 = 400$ K and $P_0 = 0.1$ MPa.

4.4. MURI2 surrogate

Laminar burning velocities measurements for the second generation MURI2 surrogate (*n*-dodecane/iso-octane/1,3,5-trimethylbenzene/*n*-propylbenzene 49.6/24.3/19.8/6.3 in mass%) are presented in Fig.8. These results are included in this study as results for a complex surrogate (four components) and to be compared with other surrogates. To the knowledge of the authors, there is no experimental data to compare with. Indeed, only one article [12] deals with laminar burning velocities of MURI2 surrogate, but experimental measurements were carried with air with a N_2/O_2 volume ratio of 86/14, too distant of our study to be compared.

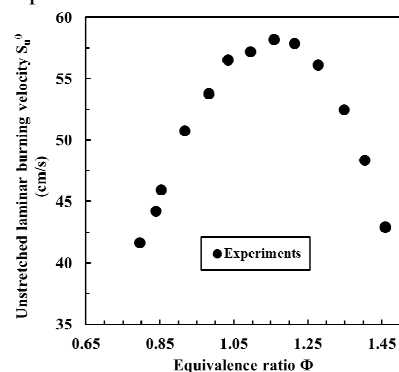

Fig.8. Unstretched laminar burning velocity S_u^0 plotted against equivalence ratio ϕ for a MURI2-air premixed flame at $T_0 = 400$ K and $P_0 = 0.1$ MPa.

4.5. Comparison

The different jet fuels surrogates employed in this study have some different behaviors concerning the laminar burning velocities, but the amplitude of the difference is not highly significant. Indeed, a maximum difference of 5 % is observed between the maximum values of the flame speed for the jet fuels surrogates (Fig.9). On the other hand, the maximum difference for the optimum equivalence ratio is around 10 %. Main differences can be observed for very lean or very rich mixtures where the differences can reach 18 % for $\phi = 0.75$ and 29% for $\phi = 1.45$.

The analysis of the unburnt Markstein lengths in Fig.10 confirm the previous comment on the similarity

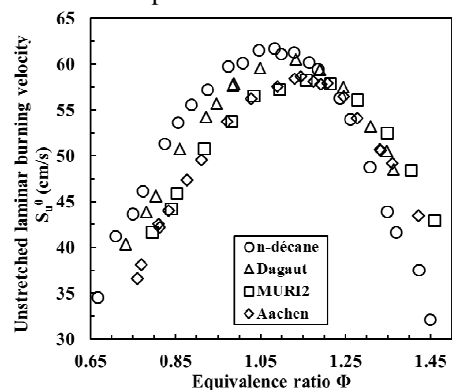

Fig.9. Unstretched laminar burning velocity S_u^0 plotted against equivalence ratio ϕ for the different jet fuels surrogates at $T_0 = 400$ K and $P_0 = 0.1$ MPa.

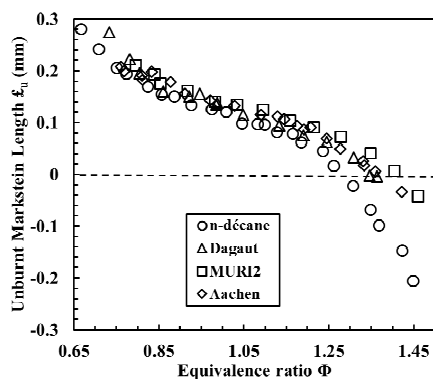

Fig.10. Unburnt Markstein length ξ_u plotted against equivalence ratio ϕ for the different jet fuels surrogates at $T_0 = 400$ K and $P_0 = 0.1$ MPa.

between the different jet fuel surrogates. Stability of the flame is globally the same with a transition from stable to unstable flame for an equivalence ratio between 1.3 and 1.4 for tested conditions.

5. Conclusions

Laminar burning velocities and Markstein lengths of different jet fuel surrogates was measured by using a new spherical combustion chamber developed at Institut PPRIME for initial pressure $P_0 = 0.1$ MPa, initial temperature $T_0 = 400$ K and equivalence ratios range of 0.7-1.5. After a validation of the experimental technique with methane-air premixed flames at normal pressure and temperature, results were obtained for the following kerosene surrogates premixed with air with increasing complexity: *n*-decane, Aachen surrogate, Dagaut surrogate and MURI2 surrogate. It can be concluded that the different surrogates globally display similar trends concerning laminar burning velocities. Additionally, numerical simulations were performed in order to validate chemical kinetic mechanisms representing different surrogates available in the literature. In particular, the Luche reduced mechanism and JetSurF2.0 mechanism are able to reproduce correctly the behaviour of respectively *n*-decane and Dagaut surrogate in the investigated conditions. On the contrary, Chang and Honnet mechanisms have more difficulty representing the *n*-decane and the Aachen surrogates respectively.

Acknowledgements

This work was financially supported by Safran, MBDA and ANR in the framework of the CAPA Chair project on innovative combustion modes for airbreathing propulsion.

References

[1] Aviation benefits beyond borders. Technical report, Air Transport Action Group (ATAG), 2016
 [2] Flightpath 2050 Europe's vision for aviation – Report of the high level group on aviation research. Technical report, Advisory Council for Aviation Research and innovation in Europe (ACARE), 2011.
 [3] E. Wintenberger, J.E. Shepherd, J. Prop. Power 22 (2006) 694-698.

[4] S.S. Shy, C.C. Liu, W.T. Shih, Comb. Flame 157 (2010) 341-350.
 [5] A. Violi, S. Yan, E.G. Eddings, A. Sarofim, Comb. Sci. Tech. 174 (2002) 399-417.
 [6] P. Dagaut, M. Cathonnet, Prog. Energy Combust. Sci. 32 (2006) 48-92.
 [7] S. Humer, A. Frassoldati, S. Granata, T. Faravelli, E. Ranzi, R. Seiser, K. Seshadri, Proc. Combust. Inst. 31 (2007) 393-400.
 [8] S.S. Vasu, D.F. Davidson, R.K. Hanson, Comb. Flame 152 (2008) 125-143.
 [9] S. Honnet, K. Seshadri, U. Niemann, N. Peters, Proc. Combust. Inst. 32 (2009) 485-492.
 [10] T.J. Bruno, M.L. Huber, Energy Fuels 24 (2010) 4277-4284.
 [11] S. Dooley, S.H. Won, M. Chaos, J. Heyne, Y. Ju, F.L. Dryer, K. Kumar, C.J. Sung, H. Wang, M.A. Oehlschlaeger, R.J. Santoro, T.A. Litzinger, Comb. Flame 157 (2010) 2333-2339.
 [12] S. Dooley, S.H. Won, J. Heyne, T.I. Farouk, Y. Ju, F.L. Dryer, K. Kumar, X. Hui, C.J. Sung, H. Wang, M.A. Oehlschlaeger, V. Iyer, S. Iyer, R.J. Santoro, T.A. Litzinger, T. Malewicki, K. Brezinsky, Comb. Flame 159 (2012) 1444-1466.
 [13] D. Kim, J. Martz, A. Violi, Comb. Flame 161 (2014) 1489-1498.
 [14] Luche J. (2003). Elaboration of reduced kinetic models of combustion. Application to a kerosene mechanism, PhD Thesis. LCSR Orléans.
 [15] H. Wang, E. Dames, B. Sirjean, D.A. Sheen, R. Tangko, A. Violi, J.Y.W. Lai, F.N. Egolopoulos, D.F. Davidson, R.K. Hanson, C.T. Bowman, C.K. Law, W. Tsang, N.P. Cernansky, D.L. Miller, R.P. Lindstedt (2010). A high-temperature chemical kinetic model of *n*-alkane (up to *n*-dodecane), cyclohexane, and methyl-, ethyl-, *n*-propyl and *n*-butyl-cyclohexane oxidation at high temperatures, JetSurF version 2.0.
 [16] P. Dagaut, A. El Bakali, A. Ristori, Fuel 85 (2006) 944-956.
 [17] Z. Chen, Comb. Flame 162 (2015) 2442-2453.
 [18] J. Beeckmann (2015). Uncertainties in spherical flame measurements: a collaborative study. 2nd Workshop on Laminar Burning Velocity, Rouen, France.
 [19] C. Antoine, Compt. Rend., 107 (1888) 681.
 [20] A.P. Kelley, C.K. Law, Comb. Flame 156 (2009) 1844-1851.
 [21] D.G. Goodwin, H.K. Moffat, R.L. Speth (2016). Cantera: An object-oriented software toolkit for chemical kinetics, thermodynamics, and transport processes. <http://www.cantera.org>, Version 2.2.1.
 [22] P. Clavin, Prog. Energy Combust. Sci. 11 (1985) 1-59.
 [23] G.P. Smith, D.M. Golden, M. Frenklach, N.W. Moriarty, B. Eiteneer, M. Goldenberg, C.T. Bowman, R.K. Hanson, S. Song, W.C. Gardiner, Jr, V.V. Lissianski, Z. Qin. (1999). "GRI-Mech Homepage".
 [24] Y. Chang, M. Jia, Y. Liu, Y. Li, M. Xie, Comb. Flame 160 (2013) 1315-1332.
 [25] F. Halter, T. Tahtouh, C. Mounaïm-Rousselle, Comb. Flame 157 (2010) 1825-1832.
 [26] E. Varea, V. Modica, A. Vandel, B. Renou, Comb. Flame 159 (2012) 577-590.
 [27] D. Singh, T. Nishiie, L. Qiao, Comb. Sci. Tech. 183 (10) (2011) 1002-1026 .
 [28] A. Comandini, T. Dubois, N. Chaumeix, Proc. Combust. Inst. 35 (2015) 671-678
 [29] Y. Wu, V. Modica, F. Grisch, Proc. of the European Combustion Meeting 2015 – Paper P3-47.