



HAL
open science

Preparative two dimensional separations involving liquid–liquid chromatography

Léa Marlot, Karine Faure

► **To cite this version:**

Léa Marlot, Karine Faure. Preparative two dimensional separations involving liquid–liquid chromatography. *Journal of Chromatography A*, 2017, 1494, pp.1-17. 10.1016/j.chroma.2017.03.031 . hal-01515553

HAL Id: hal-01515553

<https://hal.science/hal-01515553>

Submitted on 23 Jul 2020

HAL is a multi-disciplinary open access archive for the deposit and dissemination of scientific research documents, whether they are published or not. The documents may come from teaching and research institutions in France or abroad, or from public or private research centers.

L'archive ouverte pluridisciplinaire **HAL**, est destinée au dépôt et à la diffusion de documents scientifiques de niveau recherche, publiés ou non, émanant des établissements d'enseignement et de recherche français ou étrangers, des laboratoires publics ou privés.

1
2
3
4 **Preparative two dimensional separations involving Liquid-Liquid Chromatography**
5

6 Léa Marlot and Karine Faure

7 Université de Lyon, CNRS, Université Claude Bernard Lyon 1, ENS de Lyon, Institut des Sciences
8 Analytiques, UMR 5280, 5 rue de la Doua, F-69100 VILLEURBANNE, France

9 karine.faure@isa-lyon.fr

10
11
12 **Abstract**

13
14 The increasing performances of analytical techniques, especially two-dimensional liquid
15 chromatography hyphenated with highly sensitive detectors, allow discovery of new targeted
16 compounds in highly complex samples, whether biomarkers in environmental effluents, natural
17 metabolomes in natural products or unknown impurities in synthetic chemical process. While
18 structural identification can usually be achieved through mass spectrometry and databases, it can be
19 useful to confirm the potential structure via NMR analysis and/or to obtain standard reference
20 material for quantitative purposes, incentive for the production of μg to mg of new target compounds.
21 Hence, preparative chromatography, which was initially run for large-scale production, is now facing
22 new challenges, with small volumes of highly complex samples to deal with. Unfortunately, one
23 dimensional chromatographic methods exhibit limited performances when targets are minor
24 compounds in a complex matrix. Moreover, for process intensification or limited amount of sample, it
25 is now a priority to be able to isolate multiple components with the largest yield possible using as few
26 purification steps as possible. With these specifications in mind, a comprehensive multidimensional
27 chromatographic method for preparative purposes is becoming appealing.

28 Liquid-liquid chromatography, also known as countercurrent chromatography or centrifugal partition
29 chromatography, is a technique with a proven high loading capacity, working with multiple choice of
30 solvent systems thus a large range of polarity and selectivity. The liquid nature of the stationary phase
31 prevents sample denaturation, irreversible adsorption resulting in high sample recovery. All these
32 qualities make the LLC technique highly receivable as a first dimension in a 2D strategy, whether
33 combined with another LLC method or with a more conventional LC method. In this review, both
34 hyphenations are investigated from an instrumentation point of view, detailing systems selection
35 methodology and two dimensional development strategy. Preliminarily, the specific LLC
36 instrumentation is briefly summarized in this review and the nomenclature of two dimensional
37 separation as well as the associated criteria are clearly explained and defined.
38

39
40 **Introduction**

41
42 In the late 1960s, Ito invented countercurrent chromatography (CCC) [1], a liquid chromatography
43 technique which originality remains in the liquid nature of the stationary phase. The name
44 countercurrent chromatography was derived by analogy to Craig's countercurrent distribution system
45 implemented in 1940s [2-4]. This chromatographic concept led to two different instrumental
46 developments. Ito pursued the development of the original hydrodynamic CCC apparatus (Figure 1a)
47 [5, 6] whereas Nunogaki focus on a hydrostatic version (Figure 1b) called centrifugal partition
48 chromatography (CPC) [6, 7]. Both technologies are based on the use of a liquid stationary phase and

49 a liquid mobile phase between which the solutes partition, their difference being only the way the
50 centrifugal field is applied. Hence, for the sake of the reader's understanding, the global technique is
51 called Liquid-Liquid Chromatography (LLC) in this review, independently of the instrument used.

52 In hydrodynamic CCC instruments, the stationary phase is retained by centrifugal forces in a planetary
53 spinning coil while in hydrostatic CPC, the stationary phase retention is assisted by the use of tiny
54 oblong or rectangular chambers connected by capillary ducts rotating around a single axis (Figure 1).
55 It should be clear that the basic theory and concepts are the same for both apparatus. Only the
56 instrumentation and the way the phases intermingle differ.

57

58 [here Figure 1]

59

60 The main specifications of LLC are related to the liquid nature of the stationary phase [6, 8]. Compared
61 to LC, the LLC technique allows a larger sample loading capacity, with a relatively low number of
62 chromatographic plates [8, 9], which classify it mainly as a preparative technique. Moreover, many
63 solvent systems are available and overlay a wide range of polarity of compounds [10]. Both phases of
64 the solvent systems can be used as mobile or stationary phase, which drastically decreases the cost of
65 the columns as compared to conventional preparative LC columns.

66 The most important advantage is the total sample recovery. Since no supporting matrix is employed,
67 the separation is not distorted by solute adsorption or catalytic change encountered with solid
68 supports. Moreover, the solutes remaining in the column can be easily recovered by extrusion of the
69 liquid stationary phase.

70

71 Liquid-Liquid Chromatography, LLC, has progressed both instrumentally and methodologically in last
72 decades, to be an effective technique for isolation and purification. It has found a large audience in
73 the natural products science area [4, 9, 11-14], which represents a rich source of biologically active
74 compounds, widely used for medical purposes for centuries, driving nowadays pharmaceutical
75 development. More recently, innovative coupling strategies have been carried out in order to develop
76 the separation power and the detection potential. In 2014, Michel et al. have described these coupling
77 strategies in a review [15] highlighting the online coupling strategy in an instrumental point of view. It
78 includes the online hyphenation of LLC with different detectors such as MS and NMR but also with
79 other chromatographic techniques such as LLC, HPLC or GC, with an analytical goal. In 2016, Xie et al.
80 published a review concerning the combinations of prep-HPLC with other chromatographic techniques
81 applied to traditional Chinese medicine [16] mentioning some online and offline couplings of LLC with
82 LC at preparative scale.

83

84 The goal of the present review is to provide an overview of the two dimensional two dimensional
85 preparative separations involving LLC technique. Under our investigation, 12 publications were found
86 involving the hyphenation of the LLC technique with another LLC apparatus in online and offline modes
87 since 2002 (Table 1). Of these 12 applications, only one application was implemented at analytical scale
88 with a view for a preparative scale transfer. The other applications were implemented directly at
89 preparative scale in order to recover the compounds of interest.

90 Since 2007, 21 publications were found involving the hyphenation of the LLC technique with LC in two
91 dimensional two dimensional separations in online and offline modes (Table 2). Of these 21
92 publications, three applications were implemented at analytical scale with a possible preparative scale
93 transfer. The other applications were implemented at preparative scale.

94 Some hyphenations of LLC with GC were found in literature as two dimensional two dimensional
95 separations [17, 18] but these hyphenations are outside the research framework presented here due
96 to the obstacle of preparative scale transfer.

97

98

99 **Nomenclature and criteria for two dimensional separations**

100

101 In the liquid chromatography field, several studies have been published in order to clearly define the
102 term of two dimensional separation and the associated notions. This is not the case in LLC field and
103 several terms are incorrectly employed in LLC publications without any theoretical background.

104 In 2007 and 2008, Stoll et al. [19], Dugo et al. [20] and Guiochon et al. [21] published three studies
105 introducing the theory and applications of multidimensional liquid chromatography. In 2009, another
106 review has been published by François et al. [22] focusing on the fundamental aspects of
107 multidimensional liquid chromatography. From these reviews, the term “two-dimensional liquid
108 chromatography” refers to the technique in which two independent liquid phase separation systems,
109 noted ¹D and ²D for first and second dimensions, are applied to the sample. The largest benefit of
110 combining columns in two dimensional configuration is the improvement of peak capacity, which is
111 reflected in the reduction of component overlap. When the selected separation mechanisms provide
112 completely different selectivities, the advantages of the two dimensional approach are fully exploited,
113 since the potentiality of co-eluting sample components in both dimensions are severely minimized.
114 Separation potential quickly increases as the correlation between the retention mechanisms
115 decreases. In a preparative sense, this resolution improvement relates to the purity that can be
116 expected.

117
118 Two distinctions have to be done dependent on the way the effluent is transferred from the first
119 dimension column to the second dimension column. The two dimensional separation can be
120 implemented in online or in offline mode. In offline two dimensional separations, the execution is very
121 simple since the fractions of the first dimension effluent are collected, after which they are
122 concentrated if necessary and re-injected on the second column. However, this method can be time
123 consuming, difficult to automate and reproduce, susceptible to sample loss and contamination. In
124 online mode, the columns in the two dimensions are connected via an appropriate interface. This
125 approach is more difficult to implement and to operate, however, faster and more reproducible.

126
127 Two dimensional separations can be done by transferring either only the interesting portion of the first
128 dimension, this is referred to as chromatography in heart-cut mode, or by sequentially transferring the
129 entirety of the first dimension effluent, in many small aliquots, to the second dimension; this is known
130 as comprehensive chromatography. In 2012, Schoenmakers team published an update concerning the
131 nomenclature and the conventions in comprehensive multidimensional chromatography [23]. In this
132 update, the comprehensiveness is clearly defined and the term “comprehensive analysis” does not
133 mean “analyzing everything”. Three criteria were established: 1- Every part of the sample is subjected
134 to two different (independent) separations; 2- Equal percentages (either 100% or lower) of all sample
135 components pass through both columns and eventually reach the detector; 3- The separation
136 (resolution) obtained in the first dimension is essentially maintained.

137 In a preparative view, these three criteria can be applied, keeping in mind that the percentage of
138 transfer will have a huge influence on the final yield of the product.

139
140 In two dimensional LC, numerous approaches are available to evaluate the separation power of the
141 column combination. In the literature, the measurement of the peak capacity can be found as well as
142 the measurement of the orthogonality between dimensions. Schoenmakers [23] has defined the
143 orthogonality as two instrumental dimensions that possess different mechanisms of separation, where
144 elution times in the two dimensions can be treated as statistically independent. Orthogonal separation
145 mechanisms depends on the sample and the specific physical-chemical interactions that the solutes
146 have with the systems. The orthogonality between two systems exists since the systems provide
147 different selectivities which are the abilities of the chromatographic systems to chemically distinguish
148 the sample components. The higher the orthogonality, the better the separation power.

149
150 In order to evaluate the orthogonality of a two dimensional separation, the retention times of the
151 compounds in first and second dimensions have to be plotted on a two-dimensional map (as presented
152 in Figure 2). For LLC two dimensional separations, the partition coefficients K_d values (and the

153 retention factors k values for HPLC separations) can be plotted instead of retention times in order to
154 eliminate the variations of the column dimensions and operating conditions. Obviously, if the
155 separations are strongly correlated (Figure 2 a and b), critical pairs in a dimension will remain close in
156 the second dimension and hence the loading capacity in preparative chromatography will remain low.
157 At the opposite, if no correlation exists between the two dimensions (Figure 2d), it is possible to
158 produce highly concentrated fractions of overlapping compounds using the first dimension knowing
159 that the second dimension will afterwards separate the coeluting compounds.

160
161 Several approaches can be found in the literature to measure and optimize orthogonality. These
162 approaches can be thermodynamic approaches which only consider the retention data of the
163 compounds or can be thermodynamic and kinetic models which also include peak broadening.

164 The bin-counting method proposed by Gilar et al. [24, 25] is strongly affected by the bins width decision
165 that the user makes to divide the separation space .

166 Slonecker et al. proposed to described the orthogonality by information theory [26]. Such mutual
167 information includes peaks which cluster along the upward diagonal of the separation space. The
168 proportion of mutual information compared to the total separation space is expected as low as
169 possible. The limitation of this method is the reliance on the assumption that peaks only cluster along
170 the upward diagonal.

171 Liu et al. developed a geometrical approach based on the factor analysis [27]. This method shares the
172 same limitation than the previous one due to the assumption that peaks only cluster along the upward
173 diagonal.

174 In the convex-hull approach [28], the retention space of the compounds is defined by an area which is
175 delimited by the most distant points on the two dimensional representation. The orthogonality is
176 directly linked to this area. Empty parts of the separation space may introduce bias on orthogonality
177 evaluation.

178 The nearest-neighbor distance approach has been proposed by Nowik et al. [29, 30] in order to
179 calculate the distance from a given peak to its closest neighbor. The harmonic mean can be related to
180 the degree of the clustering. This method is however highly dependent on the number of the peaks
181 within the separation space.

182 The asterisk equations approach proposed by Schoenmakers [31] is based on the normalized retention
183 data of the compounds in each dimension. Despite the easy use of this method, the calculation of the
184 orthogonality is based on normalized data which do not represent the effective total separation space.

185
186 While this list may not be exhaustive, these proposed methods for measuring chromatographic
187 orthogonality have their limitations and should be compared and discussed. But when dealing with
188 preparative chromatography, these notions are not taken into account so far and to the best of our
189 knowledge, orthogonality evaluation has never been applied to the LLC field, not to mention
190 optimization. In this review, we will focus on the first pre-requisite, i.e. two-independent separation
191 mechanism for a preliminary evaluation of orthogonality.

192 For this purpose, two parameters can be taken into account. The first parameter is the global
193 correlation coefficient of the 2D-plot r^2 . Orthogonal separation mechanisms by definition should not
194 be correlated, thus the peaks should spread throughout the separation space. As shown in the Figure
195 2, when the correlation coefficient is equal to 1 (Figure 2a), the chromatographic interactions endured
196 by the solutes are similar which means absence of orthogonality between the systems. As explained
197 by Stoll et al. [19] and presented in Figure 2c, the 2D-plot correlation coefficient r^2 can be low without
198 an important utilization of the two dimensional separation space. Thus, to ensure a higher
199 orthogonality of the two dimensional separation, which will relate to better resolution and hence
200 better purity in preparative schemes, the coefficient correlation r^2 has to be close to 0 and the
201 separation space has to be the largest as possible (Figure 2d). Moreover, in preparative
202 chromatography, a special attention should be brought to clusters (Figure 2c). Indeed, while during
203 method development, the compounds may appear resolved with sufficient purity using 2D separation,

204 the production aim, even set at few mg, provide the incentive for concentration and loading, which
205 inevitably results in peak broadening and overlapping.

206
207 [here Figure 2]

208 209 210 **Two dimensional LLC-LLC separations**

211
212 From 1998 until 2015, the concept of two dimensional LLC-LLC separation have only been investigated
213 on CCC apparatus, meaning coil-based instruments. Table 1 reports the publications found under our
214 investigations, classified according to the selected transfer strategy, either online or offline. The
215 interface, the fractions volume, and the instrumentation are described for comparison. The solutes are
216 indicated in the references but are not the main purpose of the discussion here.

217 These two-dimensional separations have mainly been developed for preparative purposes of selected
218 solutes, so only heart-cut mode was carried out, meaning that a limited number of fractions from the
219 first dimension were transferred to the second dimension. Up to date, 17% of the applications are
220 implemented in offline mode, thereby 83% of the applications are implemented in online mode.
221 Compared to the offline mode, the online hyphenation needs a special equipment and technical skills.
222 The fraction of interest from the first dimensional LLC has to be transferred in the second dimensional
223 LLC with a special interface such as a switching valve, a sample loop or a solid-phase interface.

224 225 **1- Switching valve interface**

226
227 The very first online LLC-LLC separation using a switching valve was performed by Ito's group in 1998
228 [32] where only one fraction from the first dimension was directly introduced to the second dimension.
229 As shown in Figure 3, the switching valve directly connects the ¹D eluent to the ²D column. The second
230 column was equilibrated and kept in rotation, while the elution in the first column was running with
231 UV detection and fraction collection. When the peak of interest was eluting out the first column, the
232 valve was switched to introduce the ¹D eluent directly to the second LLC column. After peak transfer,
233 the valve was switched back to loading position, the pump of the second instrument was started and
234 the elution of the selected targets could run in the ²D column while the ¹D elution was back in process.
235 In the cited reference, the solvent system used in the secondary column was the exact same than the
236 one used in the primary column. Indeed, Ito developed this instrumentation in order to lengthen the
237 column to increase resolution on selected parts of the chromatogram, which implies using the same
238 solvent system in first and second coils. This application cannot then be considered as a two
239 dimensional separation, since the same separation mechanism is implemented in both coils. However,
240 this instrumentation set the stage for further 2D CCC development.

241
242 [here Figure 3]

243
244 If the first objective was to lengthen the column with this instrumentation, Ito's group developed then
245 three others applications in 2002, 2005 and 2006 using the same HSCCC apparatus and the same
246 interface for 2D separations [33-35]. In each paper, only one fraction of interest was introduced in the
247 second LLC column (heart-cut mode). As a part of the ¹D eluant is directly carried into the second LLC
248 column, the second solvent system has to be stable towards the ¹D mobile phase, to avoid
249 hydrodynamic equilibrium perturbation and ²D stationary phase loss. In 2002 and 2006, Ito's group
250 used the very same solvents for the two columns or slightly changed the composition of the ²D solvent
251 system [33, 35], which can be considered once again as a lengthening of the column. In 2005, however,
252 the *n*-hexane/dichloromethane solvent in first dimension was switch to chloroform in the second
253 dimension solvent system which apparently did not perturb the hydrodynamic equilibrium [34]. It can
254 be considered with these two slightly different columns, hence selectivity, that 2D-CCC emerged. With
255 this direct introduction strategy, the solvent compatibility is the main issue and only slight changes of

256 composition are allowed. In terms of orthogonality, this strategy can only provide a weak improvement
257 of the selectivity and peak separation.

258
259 More recently, Englert et al. [36] implemented online two dimensional separations using the same
260 switching valve strategy. Englert et al. used a second dimension to slightly change the selectivity on a
261 critical pair. The K_d values of the compounds in the cited solvent systems were estimated, thus the 2D
262 orthogonality representation can be illustrated as shown in Figure 4. The correlation coefficient is
263 found at 0.875. This coefficient being close to 1, the separation mechanisms of the two dimensions are
264 considered highly similar and consequently the orthogonality between the two dimensions is low.
265 Changing *n*-hexane by cyclohexane did not bring selectivity as much as expected and the similar
266 separation mechanisms limited separation improvements.

267
268 [here Figure 4]

269
270 The main strategy developed in the works using a direct transfer of fractions from one column to
271 another was to establish a first LLC separation with the best peak resolution and selectivity in a
272 reasonable elution time and then to send only the unresolved compounds, usually one critical pair, to
273 the second dimension for further separation. Unfortunately, because of the liquid nature of the ²D
274 stationary phase, the transfer of a large volume of ¹D mobile phase impacts the ²D column stability and
275 drastically reduces the choice of the ²D solvent system. With this kind of interface, the two dimensional
276 potential of the separation cannot be fully exploited.

277 278 **2- Sample loop interface**

279
280 As in 2D-LC, a sample loop can be used as interface. In 2007, Pan's group decided to implement a two
281 dimensional separation using a sample loop for a precise control of the transferred volume. A 146-ml
282 HSCCC column was used as first dimension and one 1500-ml CCC coil was used as second dimension.
283 As shown in Figure 5, a 50-ml sample loop was used as interface with three 3-port valves. In a first step,
284 the ²D column was equilibrated while the injection of the sample in the first dimension was made. The
285 valves were switched to introduce the peak of interest to the sample loop. When the cut was over, the
286 valves were switched back to transfer the loop content in the second LLC column and the ²D elution
287 ran while the elution in the first dimension was still in process. With this interface, the solvent
288 compatibility problem is somehow minimized as the transferred volume represents only 3% of the ²D
289 column volume. However, precautions are still taken in the solvent system selection to avoid
290 hydrodynamic equilibrium perturbation. Indeed, it can be seen that Pan's group selected the same
291 solvents for the two columns (*n*-hexane-ethyl acetate-methanol-water) and just changed their
292 respective percentages (1:5:1:5 in ¹D to 3:5:3:5 in ²D). As expected, this choice limited the equilibrium
293 perturbation, but kept the orthogonality low.

294 In the following years, the same group used this 2D instrumentation with loop interface in various coil
295 configurations, transferring to the second dimension from 6% column volume [38] to 14% column
296 volume [39].

297
298
299 [here Figure 5]

300
301
302 As for the previous interface, it is regretful that no global two dimensional strategy was employed for
303 the selection of solvent systems. In the three publications, one or two compounds have undergone the
304 full two dimensional separation so the analysis of an orthogonality plot is not relevant.

305 306 307 **3- Solid-phase trapping column interface**

308

309 In 2010, Pan's group decided to implement a solid-phase trapping interface in the online two
310 dimensional LLC-LLC instrumentation [40]. For this hyphenation, one 6-port switching valve, one 4-
311 port switching valve and one trapping column were used with a make-up pump as presented in Figure
312 6. This configuration using two columns (coils) inside a single LLC instrument was named
313 "multichannel". By switching valves, the peak of interest from the first dimension was loaded in the
314 trapping column (Oasis HLB sorbent) after water was added with a make-up pump to increase analyte
315 retention on the trap. Nitrogen was flushed to dry the column and remove any residual solvents. Then
316 the trapped analytes were back-flushed to the second LLC column with the ²D mobile phase, while the
317 elution was still running in first dimension. The serious advantages of this interface are the avoiding of
318 a large volume injection on the second column by the total elimination of the ¹D mobile phase and the
319 focusing effect of analytes before the second separation. The water and nitrogen flush ensure that
320 absolutely no residual solvent is sent from one dimension to the other. This extra precaution may be
321 too harsh on some analytes, which can be either degraded or irreversibly adsorbed on the trap as
322 mentioned by Pan [40, 41].

323

324 [here Figure 6]

325

326

327 In 2011, Pan's group [41] incremented their 2D instrumentation by setting a solid-phase trapping
328 interface with two trapping columns allowing two fractions to be sent to the second dimension. Once
329 again, the trapping columns were filled with Oasis HLB sorbent type. In this work, two very different
330 solvent systems were used: n-hexane/ethyl acetate/methanol/water in first dimension and methyl
331 *tert*-butyl ether/acetonitrile/water in second dimension. This major change should provide very
332 different selectivities and maximize orthogonality. Unfortunately, as seen on Figure 7, over the four
333 compounds that underwent the two dimensional separation, only the first one seems to be affected
334 by this switch. The overall correlation coefficient is 0.4317 which is globally low, but if we focus on
335 compounds 2, 3 and 4, then it is visible that correlation is high and separation mechanisms are very
336 similar. The improvement brought by the use of a second dimension is alas not obvious for these
337 compounds.

338

339 [here Figure 7]

340

341

342 This solid-phase trapping interface allows the use of two chemically different biphasic solvent systems
343 without any phase disturbance. Thus the separation mechanisms can be fully independent and the
344 selectivity and orthogonality can be improved. Unfortunately, in Pan's work, the solvent systems were
345 set up with the same solvent nature in different percentages. While the instrumentation made it
346 possible to overcome a challenge, the selection of the solvent systems in the cited examples was not
347 done as to provide completely different selectivities.

348

349 4- Offline mode

350

351 To circumvent the difficulties linked to the transfer of fractions to the second dimension, and to be
352 able to use conventional instruments in a timely manner, it is easier to physically collect fractions
353 eluting from the first separation, eventually applying a sample prep, before injection in the second
354 dimension. This is the case for 17% of the papers dealing so far with two dimensional LLC-LLC
355 separations.

356

357 The first uses of the offline mode for LLC-LLC were implemented by Chen's group in 2013 [42-44] and
358 the objective was to lengthen the column by using the same solvent system in first and second
359 dimension. The recycling mode was also used for this purpose. This mode allowed to prolong the LLC

360 separation course to improve the separation factor. These applications are then not considered as two
361 dimensional separations since the very same separation mechanism was set in the two columns.

362
363 Currently Chen's group is very active in LLC-LLC two dimensional separations in offline mode [45, 46].
364 In the two publications, the sample has been injected in the first LLC dimension then the fractions of
365 interest were collected and the solvents were evaporated before dissolution of the compounds of
366 interest in the mobile phase of the second dimension. In this mode, several fractions could be sent to
367 the second dimension. The transfer is convenient and can be applied more widely. However it needs
368 more manual steps and manipulations which can introduce errors and contaminations. In the two
369 examples shown by Chen et al., the strategy to implement the two dimensional separation was a step-
370 by-step strategy. The first biphasic solvent system allowed an efficient separation with suitable K_d
371 values with a satisfactory separation time. The second biphasic system was chosen to improve the
372 selectivity between the unseparated peaks from the first dimension. Since the solvent of the 1D
373 fraction of interest was eliminated by evaporation, the solvent system in second dimension could be
374 completely different with an important selectivity improvement. In the first publication, targeting
375 flavonoids from tartary buckwheat, two chemically different solvent systems were used: *n*-
376 hexane/ethyl acetate/methanol/water in the first dimension and ethyl acetate/*n*-butanol/water in the
377 second dimension. Unfortunately, as seen on Figure 8a, these two different solvent systems exhibit
378 almost the same interactions with the solutes so separation mechanisms are correlated and
379 orthogonality of the 2D separation is really low. The selectivity is identical and one can question the
380 need of two separations in such conditions.

381 On the contrary, for the second example from Chen's group, targeting antioxidants from *Semen cassia*
382 [46], the correlation coefficient is close to 0 (Figure 8b) and the two dimensional separation space is
383 largely occupied. Indeed, in the second dimension, an aqueous copper solution was added to the same
384 solvent system than in first dimension, to implement complexation which completely modifies the
385 solutes retention. This induces a higher orthogonality and a better separation efficiency.

386
387 [here Figure 8]

388
389 This issue of solvent system comparison according to their different selectivities towards the targeted
390 compounds is actually scarcely discussed. In 2015, das Neves Costa et al. published a new approach
391 concerning the solvent system selectivities [47]. For a given application, two suitable solvent systems
392 are selected and the K_d values of the compounds of interest in the two selected solvent systems are
393 plotted on a 2D-plot with their peak widths. This is the only representation of an experimental 2D-plot
394 in the LLC literature so far (Figure 9). It highlights the various selectivity correlations depending on the
395 compound chemical nature, for example compounds 1-4 flavonoid glycosides. Then each critical pair
396 selectivity is reported on a scale range helping in the selection of one system or the other according to
397 the selected target. While this approach is not used to develop a 2D methodology, i.e., using both solvent
398 systems for the multi-targeted sample purification, this point of view is very appealing to help the
399 selection of the best solvent system for a specific objective.

400
401
402 [here Figure 9]

403
404
405 The combination of 2D LLC-LLC have been implemented to improve the separation as compared to
406 only one dimension. While the improvement is sometimes only due to a longer column, an increase in
407 selectivity on a critical pair can most of the time make the difference. It is however regretful that the
408 orthogonal strategy is only exploited at the margin. Online interface has focused a lot of instrumental
409 effort and now with the use of solid-phase interface it can allow real two dimensional strategy for the
410 selection of solvent systems. Offline combination require time-consuming fraction handling but can
411 lead to the same results without the financial investment.

412 The difference between a heart-cutting multi-dimensional chromatographic technique and a
413 comprehensive one is that the first enables the re-injection of a limited number of multi-component
414 effluent fractions from a first to a second column, while in the comprehensive mode the entire sample
415 is subjected to separation in both dimensions. So far in the literature, only heart-cutting strategies
416 have been developed using LLC-LLC. In the case of more complex samples (over 50 compounds as
417 found in natural products for example), a better orthogonality could definitely improve peak capacity
418 and in a comprehensive strategy, allow the purification of a large number of compounds.

419

420 [here Table 1]

421

422

423 **Two dimensional LLC-HPLC separations**

424

425 The major issue restricting the use of one-dimensional solid-phase liquid chromatography (prepLC) is
426 the limited loading capacity that is due to the non-linear adsorption isotherms on solid stationary
427 phase. On the other hand, the chromatographic efficiency of particle-based prepLC results in low band
428 broadening and hence better resolution of closely retained compounds. Liquid-liquid chromatography
429 (either countercurrent chromatography, or centrifugal partition chromatography) is based on the use
430 of a liquid stationary phase. This allows the injection of large amounts of complex sample without the
431 major overloading issues encountered in LC. This LLC fractionation according to partition coefficients
432 provides to the ²D LC simplified pools of molecules and hence, concentrated amounts of minor
433 compounds can be injected without competition with major compounds.

434 Up to date, 67% of the applications were made offline. Thereby, 33% of the applications were made
435 online using different interfaces. The separations were performed in heart-cut mode but also in a
436 comprehensive mode. Both LLC instrument types, namely CCC and CPC, were used for this purpose.

437

438

439 **1- Offline mode**

440

441 To carry out an offline two dimensional LLC-HPLC separation, two ways were used in order to manage
442 the solvent compatibility for the transfer of the LLC fractions to HPLC dimension.

443 In eight publications [48-55], the fractions of interest from the LLC dimension were collected and the
444 solvents were evaporated and solubilized in the ²D mobile phase. However, sample stability upon
445 dryness and secondary dissolution in the ²D remains a delicate step to be considered. In two other
446 publications [56, 57], the collected fractions from LLC dimension were just filtrated and injected in LC
447 dimension. In this case, the mobile phases of both dimensions have to be compatible, either close in
448 composition or generating a focusing effect on the head of the LC column. Indeed, the risk of a direct
449 transfer is that the injection on the secondary LC column of a large volume with high elution strength
450 generates dispersion so that the effective number of plates of the secondary LC column is drastically
451 reduced, impairing the resolution power.

452 For the remaining publications involving LLC and LC in a 2D strategy [58-60], no method for fractions
453 transfer was mentioned.

454

455 In order to evaluate the orthogonality of the system sets, the 2D representation of the two dimensional
456 separations were investigated by plotting the K_d values of the compounds from the ¹D LLC against the
457 k values of the compounds from the ²D LC. The 2D representations are presented in Figure 10 for
458 publications providing adequate retention data [49, 53, 57, 61].

459 In Zhu et al. in 2009 [49], *n*-hexane/ethyl acetate/methanol/water was used as ¹D solvent system, the
460 recovered fractions were evaporated to dryness and solubilized in methanol to be transferred to a C18
461 stationary phase with methanol/water mobile phase. With the elimination of the ¹D mobile phase
462 before LC injection, two different dimensions were chosen without any solvent compatibility problems

463 and thus two independent separation mechanisms were carried out, as proven by the low correlation
464 in 2D plot (Figure 10a).

465 In 2015, Zhu et al. implemented a second 2D LLC-HPLC separation [53] with the same transfer strategy.
466 The 2D representation is shown in Figure 10b. With the elimination of the ¹D mobile phase before LC
467 injection, the solvent compatibility problems cannot arise. The solvent system *n*-hexane/ethyl
468 acetate/methanol/water was used as ¹D solvent system and an ODS stationary phase was
469 implemented with acetonitrile/water mobile phase for the LC separation. Nevertheless, as shown on
470 the figure, the correlation coefficient is close to 1 meaning that the separation mechanisms in the two
471 dimensions are similar for the injected compounds. In this case, orthogonality is really low despite the
472 elimination of the ¹D mobile phase before LC injection was ensured. These two examples show that
473 even when solvent compatibility has been overcome and separation media seem different, the two
474 separation mechanisms need a full investigation to be optimized.

475
476 For some examples, no evaporation of the solvents was operated between the two columns and the
477 recovered LLC fractions were directly injected as such in the secondary LC column.

478 In Wang's work [61], the aqueous-rich ¹D fraction (composition unknown) is directly sent on ²D LC
479 working at 32% methanol isocratic mobile phase. The first dimension clearly allows the separation of
480 compound 2 with its impurities from compound 1 and compound 4 (with their respective impurities).
481 On the 2D-plot (Figure 10c), it clearly appears that the LLC dimension is used as a basic fractionation
482 step before LC separation whereas the separation mechanisms could be more different and the
483 compounds could be easier to isolate. One can wonder about the usefulness of such a 2D strategy
484 compared to one-dimensional preparative separation.

485 In Chen's work [57], the ¹D mobile phase was essentially water (93% water, 7% butanol). Therefore,
486 the mobile phase of the LLC dimension was highly compatible with the reverse phase LC system. The
487 separation mechanisms in the two dimensions are different (quite low correlation coefficient on Figure
488 10d) even if the two dimensional-separation space is not fully exploited. This case can cause issue for
489 the preparative transfer because of the possible coelution of the peaks.

490
491

492 [here Figure 10]

493
494 In the reported offline LLC-LC papers, the solvent system of the first LLC dimension was chosen with
495 the same criteria than the implementation of unidimensional LLC: suitable *K_d* values for satisfactory
496 separation time, separation factor higher than 1.5, satisfactory stationary phase retention and polarity
497 close to the sample polarity if known. Then, the unseparated compounds from the first LLC dimension
498 were injected in HPLC to separate them. No optimization criteria were specifically mentioned for the
499 LC system selection.

500
501 With the 1D mobile phase either discarded or compatible, the conditions are fulfilled to offer a wide
502 range of orthogonality sets. Regrettably, with the available data, only one application exhibited
503 satisfactory orthogonality.

504
505

506 **2- Sample loop interface**

507
508 Compared to the offline mode, the online hyphenation needs a special equipment and technical skills.
509 However, its automation makes it high reproducible and easier to use. The fraction of interest from
510 the ¹D LLC has to be transferred in the ²D LC with a special interface such as a sample loop or a solid-
511 phase interface.

512
513 In 2011 and 2012, Elfakir's group published two applications of two dimensional LLC-HPLC separations
514 for analytical purposes using CPC devices [62, 63]. A 20 µl-sample loop was used with a 6-port switching

515 valve as interface between both dimensions. When the valve is in load position, the CPC outlet is sent
516 through the sample loop to the detection system. When the valve is in inject position, the effluent
517 from the CPC column present in the sample loop is sent to HPLC, during that time CPC continues to
518 operate with the CPC effluent sent to the detection system. This interface is the simplest way to
519 implement an online two dimensional LLC-HPLC separation in an instrumental view since the LLC and
520 HPLC techniques have different backpressure and flow rate values. The LLC technique is a low-pressure
521 chromatography (around 70 bars), whereas the HPLC is a high-pressure chromatography (around 400
522 bars). It is hence preferable to avoid direct injection. The techniques also use different flow rates. Small
523 scale CPC can be employed up to 15 ml/min, whereas analytical HPLC is generally set at around 1
524 ml/min. As the switching valve allows a physical separation between the two systems, physical
525 constraints are not a problem anymore.

526 However, by using a simple sample loop as interface, the mobile phase of the first dimension is still
527 present in the fraction which is transferred to the second dimension. Thus, the compatibility of the
528 mobile phases of both dimensions has to be studied to implement a satisfactory separation. In the
529 cited references, the mobile phase of the first dimension was composed of ethyl
530 acetate/methanol/water with traces of *n*-heptane whereas the mobile phase of the second dimension
531 was acetonitrile/water. The injection solvent is miscible in the ²D mobile phase, but the very high
532 elution strength should result in a very large contribution of injection process on the ²D band
533 broadening. Different parameters were investigated to avoid peak deformation in the secondary
534 separation. With a standard mixture, the injection solvent, the injected volume and the injected
535 amount were studied [62]. They concluded that, according to the HPLC column dispersion, any fraction
536 coming from the CPC column could be injected if the transferred volume did not exceed 20 µl (2% LC
537 column volume). This instrumentation is hence perfectly adapted for analytical purposes or for HPLC-
538 guided fractionation. It would be interesting to further develop this approach with a larger preparative
539 LC column as second dimension for preparative purposes.

540
541 In 2013, Wei et al. also used this interface with an 8ml-sample loop for the hyphenation of CCC and
542 LC devices at semi-preparative scale [64]. In their work, the strategy to avoid the phase compatibility
543 problems was to use similar mobile phases for the two dimensions. The ¹D mobile phase was made
544 of ethyl acetate/methanol/acetonitrile/water (exact composition undefined, but about 30% water)
545 and the ²D mobile phase was methanol/water 65:35. The transferred volume was equivalent to 15%
546 of the ²D column volume. The risk of this strategy can be the lack of selectivity between the two
547 dimensions due to the use of the same solvents. Unfortunately, retention data were not available in
548 the publication to discuss this point.

549

550

551 **3- Solid-phase trapping columns interface**

552

553 Qiu's group is the only group to have carried out solid-phase trapping columns as interface for online
554 two dimensional LLC-LC separations. This interface allows the complete elimination of the ¹D mobile
555 phase, the focusing of the solutes on the trapping columns and the transfer to HPLC with compatible
556 injection solvent. Four publications have been published in 2014 and 2015 using CCC devices and
557 preparative LC [65-68].

558

559 The interface of the first application of Qiu's group in 2014 [65] is presented in Figure 11. The fractions
560 of interest underwent a mixing step in a dynamic mixer to decrease the solvent strength by adding
561 water with a make-up pump. Then, the effluent was sent to a 2-position 10-port valve containing two
562 C18 holding columns allowing the transfer of fractions of interest to second LC dimension. Two
563 trapping columns are implemented in order to allow desorption of the solutes of the LLC fraction
564 trapped on the first trapping column towards LC column while the second LLC fraction is sent to the
565 second trapping column. With this strategy, the entire ¹D fractions can be sent to the interface for LC
566 injection without stopping the LLC elution.

567
568 [here Figure 11]

569
570 By using this interface, the ¹D solvents were eliminated. Moreover, with the use of two holding
571 columns, this interface allowed a comprehensive separation in the sense that the entire sample can
572 undergo the two dimensional separation. For this comprehensive mode, the time compatibility issue
573 between both techniques was studied. In the cited reference, the entire LLC peaks were transferred
574 to LC dimension meaning that every LLC peak requires one LC separation run. At preparative scale, the
575 LC time separation reached 60 minutes. Thus, to ensure time compatibility, a flow-programming
576 scheme was considered for the LLC implementation. In the flow-programming mode, the LLC
577 dimension was operated at a controlled flow rate to ensure that each LLC fraction eluted within LC
578 separation time frame. The rotation speed was kept the same during the whole LLC separation. This
579 strategy was also applied in 2015 with an instrumental improvement on the water addition before
580 trapping, through the use of a fragmentary dilution and turbulent mixing interface [68].

581
582 In 2014 and 2015, Qiu's group illustrated their development through two new 2D LLC-HPLC separation
583 examples [66, 67]. For these applications, the same instrumentation was enforced with the same two
584 trapping columns. In order to ensure the time compatibility between the two different techniques, a
585 stop-and-go mode was considered for the LLC implementation. While in flow-programming mode, the
586 ¹D flow rate was usually slowed down, in the stop-and-go mode, the ¹D flow rate was punctually
587 stopped (but not the CCC rotation). Indeed, the processing of the transferred fraction by LC requires
588 around 30 min, which is much more than the time required to fill up a trapping column. Thus while the
589 two trapping columns were processed, the flow rate was stopped in the CCC. It is considered that the
590 band broadening that resulted from diffusion during this holding time was not prejudicial to the ¹D
591 separation.

592
593 [here Figure 12]

594
595
596 While developing a 2D method for the isolation of coumarin derivatives from traditional Chinese plant
597 on LLC to avoid irreversible adsorption on silica [66], Qiu's group observed that for some compounds
598 which had close K_d values in LLC, their elution properties, and as first, their selectivity were different
599 in HPLC. After careful investigation concerning these differences, they choose the biphasic LLC solvent
600 system that provided a selectivity as opposite as possible to the LC selectivity. This lead to a very nice
601 multi-targeted separation of 16 compounds (Figure 12) and the isolation for the first time of two minor
602 linear coumarins and one angular coumarin. Here a real two dimensional strategy was carried out in
603 terms of solvent selection and this is the first publication to discuss resolution, efficiency and
604 orthogonality for a two dimensional separation involving LLC two dimensional. For the first time, LLC
605 solvent system was chosen in regards to the complementary selectivity LC provided as well. This
606 resulted in a full usage of the separation space and a globally low correlation coefficient. Looking closer
607 it is however visible that some compounds undergo similar separation mechanisms in the two
608 dimensions (7,8 and 9 in one group, 10,12,13 and 14 in another). Compounds 1 to 5 are separated only
609 thanks to the second dimension. This may cause issue at preparative scale when peaks may coelute
610 due to large loading. On the 2D plot, it is also easy to observe that neither LLC nor LC would have been
611 able to individually perform, as for example compounds 10,12,13,14 coelute in LLC and 3, 8 and 13
612 would not have been resolved in LC. This success clearly highlights the power of 2D separations.

613
614
615 While the common sense would consider set the high loading capacity, low efficiency, high selectivity
616 LLC technique before the high resolution LC, it is worth mentioning that some researchers
617 experimented the other way around. In 2013, Shi et al. presented a combination of preparative HPLC
618 and LLC to separate lignane derivatives [69]. They considered that for their application, neither

619 preparative HPLC nor LLC could purify all the target active compounds with high purity in one-step
620 separation. Thus, they found that the combination of preparative HPLC and LLC was efficient to reach
621 their goal because of their complementary and orthogonal properties. Surprisingly, in their strategy,
622 HPLC allowed the simplification of complex samples into fractions. They considered that HPLC is a
623 powerful technology with high efficiency and selectivity but that the resolution in preparative LC is
624 fairly low. Effectively, this is the case in their application and on the chromatogram, the resolution was
625 really poor and the selectivity between peaks of interest was clearly low. Only two fractions could be
626 recovered for seven compounds. This is the claimed reason why they used preparative LC as first
627 dimension. Then the LLC separation gave a better selectivity for the peaks and allowed the isolation of
628 the compounds with a high purity. The sample was injected through a preparative LC with a 500 x 80
629 mm column packed with 5 μm octadecylsilane stationary phase. The mobile phase was a gradient
630 composed of ethanol/water. The collected fractions were evaporated to dryness. Only two lyophilized
631 fractions were then sent to LLC separation with two different solvent systems: ethyl acetate-ethanol-
632 water (2:1:3) solvent system and petroleum ether-ethyl acetate-methanol-water (2:5:2:5) solvent
633 system were investigated. This strategy is interesting to investigate nevertheless it remains an unusual
634 one. As said previously, LC is a technique with lower loading capacity than LLC. Thus, it could be better
635 to enforce LLC as first dimension to make use of this advantage and to benefit from more
636 chromatographic plates in the second dimension to achieve proper resolution.

637
638
639

640 **Conclusion and outlook**

641

642 The two dimensional separations combining LLC technique with LLC or HPLC techniques are interesting
643 at preparative scale in order to isolate and purify compounds from a highly complex sample. From all
644 the investigated publications, including LLC-LLC and LLC-HPLC hyphenations, 90% of the applications
645 are implemented at preparative scale for further NMR identification of isolated compounds and so for
646 the production of high quality standards.

647 The two dimensional separations involve different separation mechanisms meaning different
648 selectivities and high orthogonality between the two dimensions. In order to get these different
649 separation mechanisms, a solvent switch should be performed between first and second dimension to
650 generate new column-solutes interactions. Thus, solvents compatibility problems can occur between
651 the dimensions. These issues are more significant when the second dimension possesses a liquid
652 stationary phase as the physical stability issue adds to the band broadening issue. The type of interface
653 between the dimensions has hence a major influence on the success of hyphenation. If there is no
654 compatibility problems between the two dimensions solvents (or if they are minimized by small
655 fraction volumes injection), the injection of the ¹D fraction to the second dimension can be achieved
656 in online mode by a direct transfer using a switching valve or a sample loop to control the injection
657 volume. To avoid any compatibility issue, the removal of the ¹D mobile phase solvents can be achieved
658 either off-line or online mode using solid-phase trapping columns.

659

660 The instrumental evolution shall allow an improvement of the orthogonality due to the possible
661 selectivity difference between both dimensions. Regrettably, this was not often the case in the
662 examples. A slight change in solvent system composition was mostly observed and no global two
663 dimensional strategy was enforced to select the solvent systems which could give the best
664 orthogonality. The LLC-LLC hyphenation was mainly used as a gradient strategy with a slight change in
665 solvent system composition to separate closely related compounds.

666 Beyond the instrumental evolution, the priority to enforce a two dimensional separation using the LLC
667 technique with a high peak capacity (either with another LLC or with LC) must be set on a global two
668 dimensional methodology to select the chromatographic columns offering the best orthogonality.
669 Considering 2D-plot at the first stage of method development is one of the paths that can be taken for

670 that purpose. Then multiple-targeted compounds and / or comprehensive purifications could offer
671 more to the discovery of new molecules.
672

673

674 **References**

675

676 [1] Y. Ito, Origin and Evolution of the Coil Planet Centrifuge: A Personal Reflection of My 40 Years of
677 CCC Research and Development, *Separation & Purification Reviews*, 34 (2005) 131-154.

678 [2] L.C. Craig, O. Post, Apparatus for Countercurrent Distribution, *Analytical Chemistry*, 21 (1949) 500-
679 504.

680 [3] W.D. Conway, Counter-current chromatography: Simple process and confusing terminology,
681 *Journal of Chromatography A*, 1218 (2011) 6015-6023.

682 [4] S.M.P. Guido F Pauli, J Brent Friesen, Countercurrent Separation of Natural Products, *J. Nat. Prod.*,
683 71 (2008) 1489-1508.

684 [5] Y. Ito, J.-M. Menet, Coil planet centrifuges for High-Speed countercurrent chromatography, in: J.-
685 M. Menet, D. Thiébaud (Eds.) *Countercurrent Chromatography*, Marcel Dekker, 1999, pp. 87-119.

686 [6] A. Berthod, T. Maryutina, B. Spivakov, O. Shpigun, I.A. Sutherland, Countercurrent chromatography
687 in analytical chemistry: (IUPAC Technical Report), *Pure and Applied Chemistry*, (2009) 355.

688 [7] A. Berthod, K. Talabardon, Centrifugal Partition Chromatography: operating parameters and
689 partition coefficient determination, in: J.-M. Menet, D. Thiébaud (Eds.) *Countercurrent*
690 *chromatography*, Marcel Dekker, 1999, pp. 121-148.

691 [8] W.D. Conway, *Countercurrent Chromatography: Apparatus, Theory and Applications*, VCH
692 Publishers, 1990.

693 [9] A. Berthod, Countercurrent Chromatography the support-free liquid stationary phase, in:
694 *Comprehensive analytical chemistry*, Elsevier Science, 2002.

695 [10] K. Skalicka-Wozniak, I. Garrard, A comprehensive classification of solvent systems used for natural
696 product purifications in countercurrent and centrifugal partition chromatography, *Natural Product*
697 *Reports*, (2015) 1556-1561.

698 [11] A. Berthod, M.J. Ruiz-Ángel, S. Carda-Broch, Countercurrent chromatography: People and
699 applications, *Journal of Chromatography A*, 1216 (2009) 4206-4217.

700 [12] R. Hu, Y. Pan, Recent trends in counter-current chromatography, *TrAC Trends in Analytical*
701 *Chemistry*, 40 (2012) 15-27.

702 [13] J.B.M. J Brent Friesen, Shao-Nong Chen, Guido F Pauli, Countercurrent separation of natural
703 products: an update, *Journal of natural products*, 78 (2015) 1765-1796.

704 [14] L. Yin, Y. Li, B. Lu, Y. Jia, J. Peng, Trends in Counter-Current Chromatography: Applications to
705 Natural Products Purification, *Separation & Purification Reviews*, 39 (2010) 33-62.

706 [15] T. Michel, E. Destandau, C. Elfakir, New advances in countercurrent chromatography and
707 centrifugal partition chromatography: focus on coupling strategy, *Analytical & Bioanalytical Chemistry*,
708 406 (2014) 957-969.

709 [16] X.-M. Xie, W.-Y. Sun, J.-Y. Huang, N. Polachi, L. Tong, G.-X. Sun, Preparative High Performance
710 Liquid Chromatography-based Multidimensional Chromatography and Its Application in Traditional
711 Chinese Medicine, *Chinese Journal of Analytical Chemistry*, 44 (2016) 1140-1147.

712 [17] T. Kapp, W. Vetter, Offline coupling of high-speed counter-current chromatography and gas
713 chromatography/mass spectrometry generates a two-dimensional plot of toxaphene components,
714 *Journal of Chromatography A*, 1216 (2009) 8391-8397.

715 [18] T. Inui, Y. Wang, S.M. Pro, S.G. Franzblau, G.F. Pauli, Unbiased evaluation of bioactive secondary
716 metabolites in complex matrices, *Fitoterapia*, 83 (2012) 1218-1225.

717 [19] D.R. Stoll, X. Li, X. Wang, P.W. Carr, S.E.G. Porter, S.C. Rutan, Fast, comprehensive two-dimensional
718 liquid chromatography, *Journal of Chromatography A*, 1168 (2007) 3-43.

719 [20] P. Dugo, F. Cacciola, T. Kumm, G. Dugo, L. Mondello, Comprehensive multidimensional liquid
720 chromatography: Theory and applications, *Journal of Chromatography A*, 1184 (2008) 353-368.

721 [21] G. Guiochon, N. Marchetti, K. Mriziq, R.A. Shalliker, Implementations of two-dimensional liquid
722 chromatography, *Journal of Chromatography A*, 1189 (2008) 109-168.

723 [22] I. François, K. Sandra, P. Sandra, *Comprehensive liquid chromatography: Fundamental aspects and*
724 *practical considerations—A review*, *Analytica Chimica Acta*, 641 (2009) 14-31.

725 [23] P.J. Marriott, Z.-y. Wu, P. Schoenmakers, Nomenclature and conventions in comprehensive
726 multidimensional chromatography - An update, LCGC Europe, 25 (2012).

727 [24] M. Gilar, P. Olivova, A.E. Daly, J.C. Gebler, Orthogonality of Separation in Two-Dimensional Liquid
728 Chromatography, Analytical Chemistry, 77 (2005) 6426-6434.

729 [25] M. Gilar, J. Fridrich, M.R. Schure, A. Jaworski, Comparison of Orthogonality Estimation Methods
730 for the Two-Dimensional Separations of Peptides, Analytical Chemistry, 84 (2012) 8722-8732.

731 [26] P.J. Slonecker, X. Li, T.H. Ridgway, J.G. Dorsey, Informational Orthogonality of Two-Dimensional
732 Chromatographic Separations, Analytical Chemistry, 68 (1996) 682-689.

733 [27] L.I.U. Zaiyou, D.G.J. Patterson, M.L. Lee, Geometric approach to factor analysis for the estimation
734 of orthogonality and practical peak capacity in comprehensive two-dimensional separations (English),
735 Analytical chemistry (Washington, DC), 67 (1995) 3840-3845.

736 [28] S.C. Rutan, J.M. Davis, P.W. Carr, Fractional coverage metrics based on ecological home range for
737 calculation of the effective peak capacity in comprehensive two-dimensional separations, Journal of
738 Chromatography A, 1255 (2012) 267-276.

739 [29] W. Nowik, S. Héron, M. Bonose, M. Nowik, A. Tchaplá, Assessment of Two-Dimensional Separative
740 Systems Using Nearest-Neighbor Distances Approach. Part 1: Orthogonality Aspects, Analytical
741 Chemistry, 85 (2013) 9449-9458.

742 [30] W. Nowik, M. Bonose, S. Héron, M. Nowik, A. Tchaplá, Assessment of Two-Dimensional Separative
743 Systems Using the Nearest Neighbor Distances Approach. Part 2: Separation Quality Aspects, Analytical
744 Chemistry, 85 (2013) 9459-9468.

745 [31] M. Camenzuli, P.J. Schoenmakers, A new measure of orthogonality for multi-dimensional
746 chromatography, Analytica Chimica Acta, 838 (2014) 93-101.

747 [32] F. Yang, J. Quan, T.Y. Zhang, Y. Ito, Multidimensional counter-current chromatographic system and
748 its application, Journal of Chromatography A, 803 (1998) 298-301.

749 [33] G. Tian, T. Zhang, Y. Zhang, Y. Ito, Separation of tanshinones from *Salvia miltiorrhiza Bunge* by
750 multidimensional counter-current chromatography, Journal of Chromatography A, 945 (2002) 281-
751 285.

752 [34] J. Wei, Z. Tianyou, I. Yoichiro, Preparative Separation of Tripdiolide from Chinese Traditional Herb
753 by Multidimensional CCC, Journal of Liquid Chromatography & Related Technologies, 28 (2005) 1903-
754 1911.

755 [35] Y. Wei, Y. Ito, Preparative isolation of imperatorin, oxypeucedanin and isoimperatorin from
756 traditional Chinese herb "bai zhi" *Angelica dahurica* (Fisch. ex Hoffm) Benth. et Hook using
757 multidimensional high-speed counter-current chromatography, Journal of Chromatography A, 1115
758 (2006) 112-117.

759 [36] M. Englert, L. Brown, W. Vetter, Heart-Cut Two-Dimensional Countercurrent Chromatography
760 with a Single Instrument, Analytical Chemistry, 87 (2015) 10172-10177.

761 [37] Y. Lu, C. Sun, R. Liu, Y. Pan, Effective two-dimensional counter-current chromatographic method
762 for simultaneous isolation and purification of oridonin and ponicipin from the crude extract of
763 *Rabdosia rubescens*, Journal of Chromatography A, 1146 (2007) 125-130.

764 [38] Y. Lu, R. Hu, Z. Dai, Y. Pan, Preparative separation of anti-oxidative constituents from *Rubia*
765 *cordifolia* by column-switching counter-current chromatography, Journal of Separation Science, 33
766 (2010) 2200-2205.

767 [39] Y. Lu, C. Sun, Y. Wang, Y. Pan, Two-dimensional counter-current chromatography for the
768 preparative separation of prenylflavonoids from *Artocarpus altilis*, Journal of Chromatography A, 1151
769 (2007) 31-36.

770 [40] R.H. Yanbin Lu, Yuanjiang Pan, Integrated Countercurrent Extraction of Natural Products: A
771 Combination of Liquid and Solid Supports, Analytical Chemistry, 82 (2010) 3081-3085.

772 [41] R. Hu, X. Dai, X. Xu, C. Sun, Y. Pan, Two-dimensional counter-current chromatography: 1st
773 Traditional counter-current chromatography, 2nd acid-base elution counter-current chromatography,
774 Journal of Chromatography A, 1218 (2011) 6085-6091.

775 [42] Q. Liu, S. Shi, L. Liu, H. Yang, W. Su, X. Chen, Separation and purification of bovine serum albumin
776 binders from *Fructus polygoni orientalis* using off-line two-dimensional complexation high-speed

777 counter-current chromatography target-guided by ligand fishing, *Journal of Chromatography A*, 1304
778 (2013) 183-193.

779 [43] K. Faure, E. Bouju, P. Suchet, A. Berthod, Use of Limonene in Countercurrent Chromatography: A
780 Green Alkane Substitute, *Analytical chemistry*, 85 (2013) 4644-4650.

781 [44] Q. Liu, H. Zeng, S. Jiang, L. Zhang, F. Yang, X. Chen, H. Yang, Separation of polyphenols from leaves
782 of *Malus hupehensis* (Pamp.) Rehder by off-line two-dimensional High Speed Counter-Current
783 Chromatography combined with recycling elution mode, *Food Chemistry*, 186 (2015) 139-145.

784 [45] S. Jiang, Q. Liu, Y. Xie, H. Zeng, L. Zhang, X. Jiang, X. Chen, Separation of five flavonoids from tartary
785 buckwheat (*Fagopyrum tataricum* (L.) Gaertn) grains via off-line two dimensional high-speed counter-
786 current chromatography, *Food Chemistry*, 186 (2015) 153-159.

787 [46] H. Zeng, Q. Liu, M. Wang, S. Jiang, L. Zhang, X. He, J. Wang, X. Chen, Target-guided separation of
788 antioxidants from Semen cassia via off-line two-dimensional high-speed counter-current
789 chromatography combined with complexation and extrusion elution mode, *Journal of*
790 *Chromatography B*, 1001 (2015) 58-65.

791 [47] F.d.N. Costa, G. Jerz, F.d.S. Figueiredo, P. Winterhalter, G.G. Leitão, Solvent system selectivities in
792 countercurrent chromatography using *Salicornia gaudichaudiana* metabolites as practical example
793 with off-line electrospray mass-spectrometry injection profiling, *Journal of Chromatography A*, 1385
794 (2015) 20-27.

795 [48] J.C.T. Silva, G.N. Jham, R.D.a.L. Oliveira, L. Brown, Purification of the seven tetranortriterpenoids
796 in neem (*Azadirachta indica*) seed by counter-current chromatography sequentially followed by
797 isocratic preparative reversed-phase high-performance liquid chromatography, *Journal of*
798 *Chromatography A*, 1151 (2007) 203-210.

799 [49] L. Zhu, H. Li, Y. Liang, X. Wang, H. Xie, T. Zhang, Y. Ito, Application of high-speed counter-current
800 chromatography and preparative high-performance liquid chromatography mode for rapid isolation of
801 anthraquinones from *Morinda officinalis* How, *Separation and Purification Technology*, 70 (2009) 147-
802 152.

803 [50] Z. Hou, J. Luo, J. Wang, L. Kong, Separation of minor coumarins from *Peucedanum praeruptorum*
804 using HSCCC and preparative HPLC guided by HPLC/MS, *Separation and Purification Technology*, 75
805 (2010) 132-137.

806 [51] T. Chen, Y. Liu, D. Zou, C. Chen, J. You, G. Zhou, J. Sun, Y. Li, Application of an efficient strategy
807 based on liquid-liquid extraction, high-speed counter-current chromatography, and preparative HPLC
808 for the rapid enrichment, separation, and purification of four anthraquinones from *Rheum tanguticum*,
809 *Journal of Separation Science*, 37 (2014) 165-170.

810 [52] H. Ying, J. Liu, Q. Du, Analysis and determination of oestrogen-active compounds in *fructus amomi*
811 by the combination of high-speed counter-current chromatography and high performance liquid
812 chromatography, *Journal of Chromatography B*, 958 (2014) 36-42.

813 [53] L. Zhu, B. Li, X. Liu, G. Huang, X. Meng, Purification of six lignans from the stems of *Schisandra*
814 *chinensis* by using high-speed counter-current chromatography combined with preparative high-
815 performance liquid chromatography, *Food Chemistry*, 186 (2015) 146-152.

816 [54] W. Guo, L. Wang, Y. Gao, B. Zhao, D. Wang, W. Duan, Z. Yu, Isolation of isochlorogenic acid isomers
817 in flower buds of *Lonicera japonica* by high-speed counter-current chromatography and preparative
818 high performance liquid chromatography, *Journal of Chromatography B*, 981-982 (2015) 27-32.

819 [55] T. Chen, H. Li, D. Zou, Y. Liu, C. Chen, G. Zhou, Y. Li, Separation of three anthraquinone glycosides
820 including two isomers by preparative high-performance liquid chromatography and high-speed
821 countercurrent chromatography from *Rheum tanguticum Maxim ex. Balf*, *Journal of Separation*
822 *Science*, 39 (2016) 3105-3112.

823 [56] D. de Beer, G. Jerz, E. Joubert, V. Wray, P. Winterhalter, Isolation of isomangiferin from honeybush
824 (*Cyclopia subternata*) using high-speed counter-current chromatography and high-performance liquid
825 chromatography, *Journal of Chromatography A*, 1216 (2009) 4282-4289.

826 [57] D. Chen, J. Fan, P. Wang, L. Zhu, Y. Jin, Y. Peng, S. Du, Isolation, identification and antioxidative
827 capacity of water-soluble phenylpropanoid compounds from *Rhodiola crenulata*, *Food Chemistry*, 134
828 (2012) 2126-2133.

829 [58] Q. Du, Z. Jiang, D. Wang, Excellent combination of counter-current chromatography and
830 preparative high-performance liquid chromatography to separate galactolipids from pumpkin, *Journal*
831 *of Chromatography A*, 1216 (2009) 4176-4180.

832 [59] Q.-B. Han, Y. Zhou, C. Feng, G. Xu, S.-X. Huang, S.-L. Li, C.-F. Qiao, J.-Z. Song, D.C. Chang, K.Q. Luo,
833 H.-X. Xu, Bioassay guided discovery of apoptosis inducers from gamboge by high-speed counter-
834 current chromatography and high-pressure liquid chromatography/electrospray ionization
835 quadrupole time-of-flight mass spectrometry, *Journal of Chromatography B*, 877 (2009) 401-407.

836 [60] G.-j.-s. Cheng, G.-k. Li, X.-h. Xiao, Microwave-assisted extraction coupled with counter-current
837 chromatography and preparative liquid chromatography for the preparation of six furocoumarins from
838 *Angelica Pubescentis Radix*, *Separation and Purification Technology*, 141 (2015) 143-149.

839 [61] X. Wang, Y. Liang, L. Zhu, H. Xie, H. Li, J. He, M. Pan, T. Zhang, Y. Ito, Preparative isolation and
840 purification of flavone C-glycosides from the leaves of ficus microcarpa by medium-pressure liquid
841 chromatography, high speed countercurrent chromatography and preparative liquid chromatography,
842 *Journal of Liquid Chromatography & Related Technologies*, 33 (2010) 462-480.

843 [62] T. Michel, E. Destandau, C. Elfakir, On-line hyphenation of centrifugal partition chromatography
844 and high pressure liquid chromatography for the fractionation of flavonoids from *Hippophaë*
845 *rhamnoides* L. berries, *Journal of Chromatography A*, 1218 (2011) 6173-6178.

846 [63] T. Michel, E. Destandau, L. Fougère, C. Elfakir, New 'hyphenated' CPC-HPLC-DAD-MS strategy for
847 simultaneous isolation, analysis and identification of phytochemicals: application to xanthenes from
848 *Garcinia mangostana*, *Analytical & Bioanalytical Chemistry*, 404 (2012) 2963-2972.

849 [64] Y. Wei, W. Huang, Y. Gu, Online isolation and purification of four phthalide compounds from
850 *Chuanxiong* rhizoma using high-speed counter-current chromatography coupled with semi-
851 preparative liquid chromatography, *Journal of Chromatography A*, 1284 (2013) 53-58.

852 [65] Y.-K. Qiu, X. Yan, M.-J. Fang, L. Chen, Z. Wu, Y.-F. Zhao, Two-dimensional countercurrent
853 chromatography × high performance liquid chromatography for preparative isolation of toad venom,
854 *Journal of Chromatography A*, 1331 (2014) 80-89.

855 [66] J.-L. Liu, X.-Y. Wang, L.-L. Zhang, M.-J. Fang, Y.-L. Wu, Z. Wu, Y.-K. Qiu, Two-dimensional
856 countercurrent chromatography × high performance liquid chromatography with heart-cutting and
857 stop-and-go techniques for preparative isolation of coumarin derivatives from *Peucedanum*
858 *praeruptorum* Dunn, *Journal of Chromatography A*, 1374 (2014) 156-163.

859 [67] W.-B. Chen, S.-Q. Li, L.-J. Chen, M.-J. Fang, Q.-C. Chen, Z. Wu, Y.-L. Wu, Y.-K. Qiu, Online polar two
860 phase countercurrent chromatography × high performance liquid chromatography for preparative
861 isolation of polar polyphenols from tea extract in a single step, *Journal of Chromatography B-Analytical*
862 *Technologies in the Biomedical and Life Sciences*, 997 (2015) 179-186.

863 [68] D. Wang, L.-J. Chen, J.-L. Liu, X.-Y. Wang, Y.-L. Wu, M.-J. Fang, Z. Wu, Y.-K. Qiu, On-line two-
864 dimensional countercurrent chromatography × high performance liquid chromatography system with
865 a novel fragmentary dilution and turbulent mixing interface for preparation of coumarins from *Cnidium*
866 *monnieri*, *Journal of Chromatography A*, 1406 (2015) 215-223.

867 [69] S.-Y. Shi, M.-J. Peng, Y.-P. Zhang, S. Peng, Combination of preparative HPLC and HSCCC methods
868 to separate phosphodiesterase inhibitors from *Eucommia ulmoides* bark guided by ultrafiltration-
869 based ligand screening, *Analytical & Bioanalytical Chemistry*, 405 (2013) 4213-4223.

870 [70] Q. Liu, J. Zhou, J. Yu, Y. Xie, X. Jiang, H. Yang, X. Chen, Systematic and efficient separation of 11
871 compounds from *Rhizoma Chuanxiong* via counter-current chromatography–solid phase extraction–
872 counter-current chromatography hyphenation, *Journal of Chromatography A*, 1364 (2014) 204-213.

873

874

Figure captions

875 Figure 1. Schematic design of (a) Countercurrent chromatography coil and (b) Centrifugal partition
876 chromatography rotor.

877 Figure 2. 2D orthogonality representation of two dimensional separations: (a) strong correlation
878 coefficient r^2 ; (b) low correlation coefficient r^2 and low utilization of the 2D space; (c) low correlation
879 coefficient r^2 without optimized utilization of the 2D space; (d) low correlation coefficient r^2 and
880 optimized utilization of the 2D space. Modified from [19].

881 Figure 3. First online two dimensional LLC-LLC instrumentation using a 6-port switching valve as
882 interface between 1D LLC and 2D LLC [32].

883 Figure 4. 2D orthogonality representation of a two dimensional LLC-LLC separation using switching
884 valve interface. Data from reference [36]. 1D solvent system: *n*-hexane/methyl *tert*-butyl
885 ether/methanol/water 5:2:5:3 and 2D solvent system: cyclohexane/methyl *tert*-butyl
886 ether/methanol/water 5:2:5:3.

887 Figure 5. Homemade column switching system interface used by Pan's group between 1D LLC and 2D
888 LLC. Modified from [37].

889 Figure 6. Solid-phase trapping column interface used by Pan's group between 1D LLC and 2D LLC.
890 Modified from [40].

891 Figure 7. 2D orthogonality representation of a two dimensional LLC-LLC separation using solid-phase
892 trapping columns interface. Data from reference [41]. 1D solvent system: *n*-hexane/ethyl
893 acetate/methanol/water 1:1:1:1 and 2D solvent system: methyl *tert*-butyl ether/acetonitrile/water
894 2:2:3.

895 Figure 8. 2D orthogonality representations two dimensional LLC-LLC separations in offline mode: (a)
896 1D solvent system: *n*-hexane/ethyl acetate/methanol/water 3:5:3:5 and 2D solvent system: ethyl
897 acetate/*n*-butanol/water 7:3:10, data from [45]; (b) 1D solvent system: petroleum ether/ethyl
898 acetate/methanol/water 1:1:1:1 and 2D solvent system: petroleum ether/ethyl
899 acetate/methanol/water + Cu^{2+} 1:1:1:1, data from [46].

900 Figure 9. Experimental 2D-plot implemented in das Neves Costa et al. solvent system selection
901 approach. Modified from [47].

902 Figure 10. 2D orthogonality representations of offline LLC-HPLC two dimensional separations: (a) 1D
903 solvent system: *n*-hexane/ethyl acetate/methanol/water 6:4:5:5 and 2D system: C18 in
904 methanol/water 60:40 isocratic mobile phase; Data from Zhu et al. [49]; (b) 1D solvent system: *n*-
905 hexane/ethyl acetate/methanol/water 1:1:1:1 and 2D system: ODS in acetonitrile/water 50:50 isocratic
906 mobile phase; Data from Zhu et al. [53]; (c) 1D solvent system: methyl *tert*-butyl ether/ethyl acetate/1-
907 butanol/acetonitrile/modified water 1:3:1:1:5 and 2D system: ODS in methanol/water isocratic mobile
908 phase; Data from Wang et al. [60] and (d) 1D solvent system: ethyl acetate/*n*-butanol/water 0.5:4.5:5
909 and 2D system: C18 in methanol/water isocratic mobile phase; Data from Chen et al. [57]

910 Figure 11. Solid-phase trapping columns interface between 1^{st} dimensional LLC and 2^{nd} dimensional
911 HPLC. Modified from [65].

912 Figure 12. Two dimensional LLC-HPLC separation using solid-phase trapping columns interface and
913 stop-and-go mode [66] and its corresponding 2D orthogonality representation: 1D solvent system: *n*-
914 heptane/acetone/water 31:50:19 and 2D system: C18 in methanol/water gradient as mobile phase.

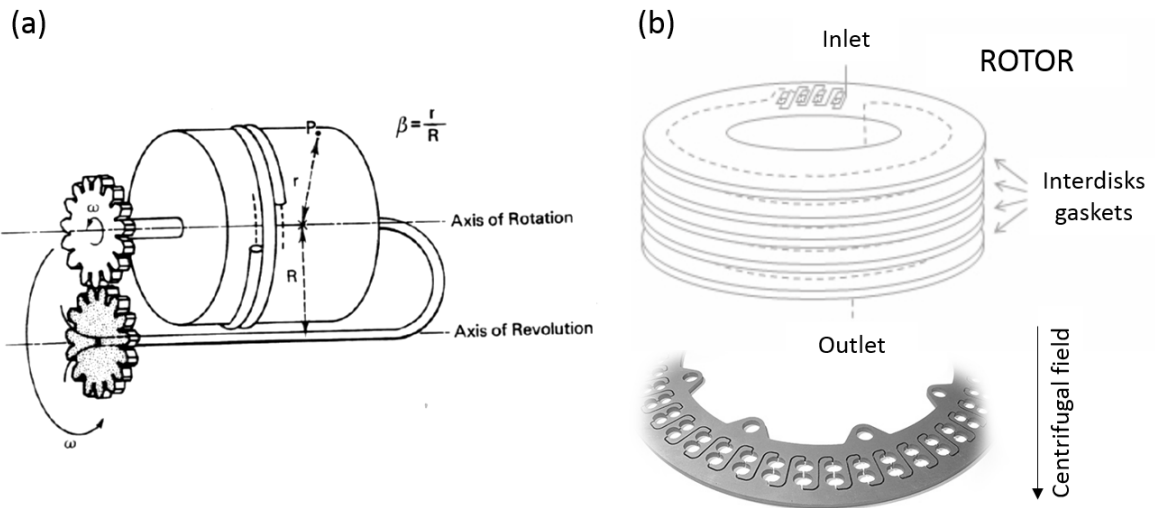

915

916 Figure 1. Schematic design of (a) Countercurrent chromatography coil and (b) Centrifugal partition
 917 chromatography rotor.

918

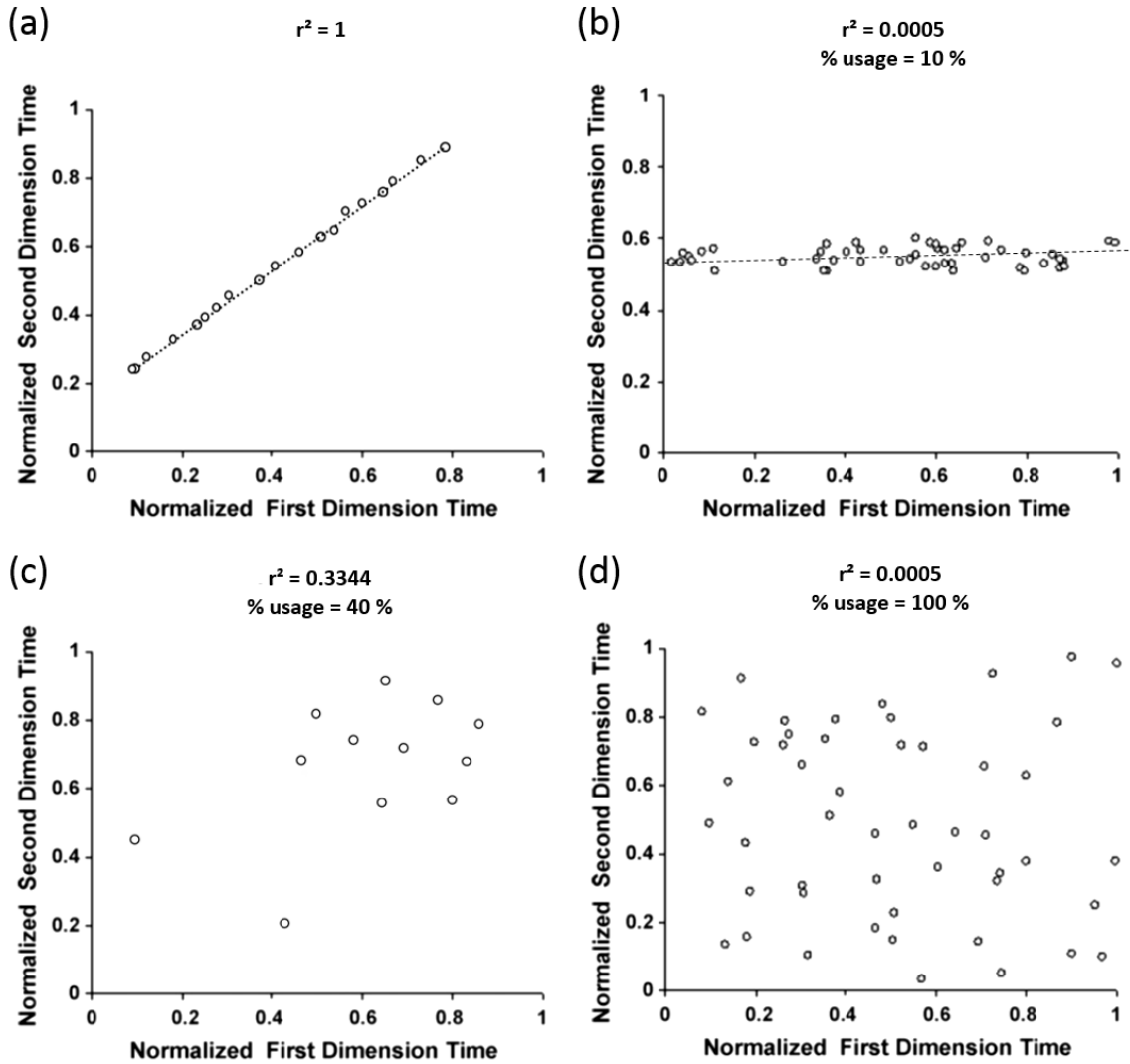

919

920 Figure 2. 2D orthogonality representation of two dimensional separations: (a) strong correlation
 921 coefficient r^2 ; (b) low correlation coefficient r^2 and low utilization of the 2D space; (c) low correlation
 922 coefficient r^2 without optimized utilization of the 2D space; (d) low correlation coefficient r^2 and
 923 optimized utilization of the 2D space. Modified from [19].

924

925

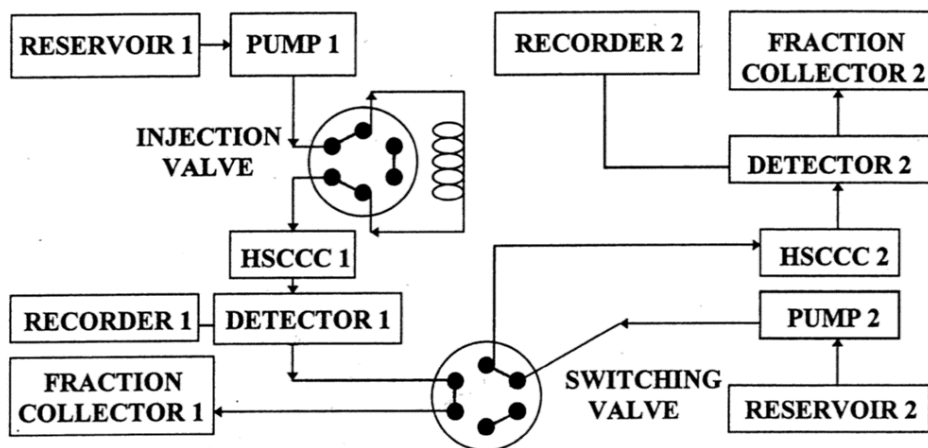

926

927 Figure 3. First online two dimensional LLC-LLC instrumentation using a 6-port switching valve as
 928 interface between ¹D LLC and ²D LLC [32].

929

930

931

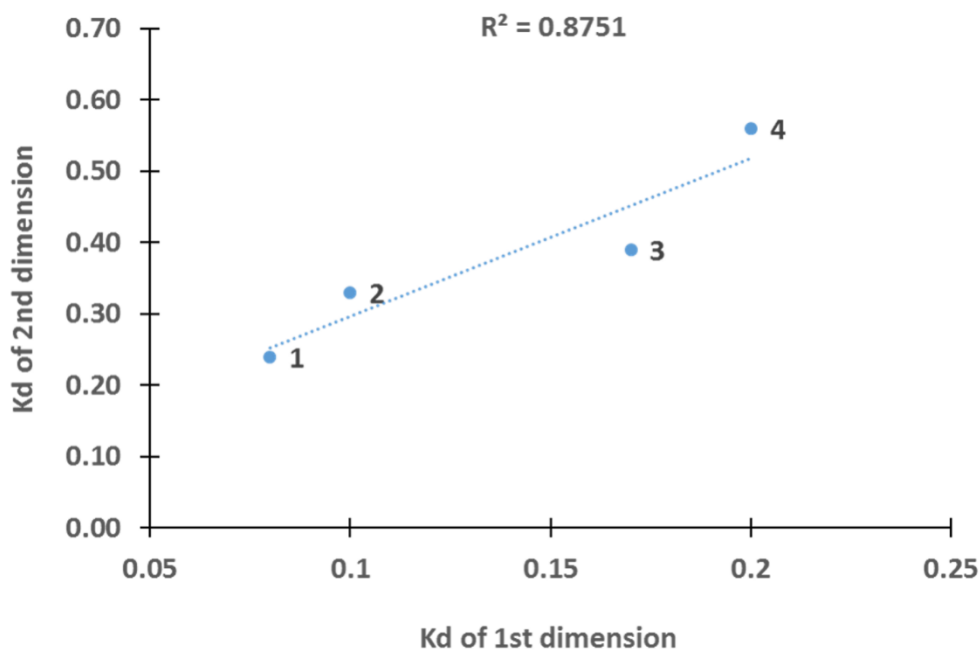

932

933 Figure 4. 2D orthogonality representation of a two dimensional LLC-LLC separation using switching
 934 valve interface. Data from reference [36]. ¹D solvent system: *n*-hexane/methyl *tert*-butyl
 935 ether/methanol/water 5:2:5:3 and ²D solvent system: cyclohexane/methyl *tert*-butyl
 936 ether/methanol/water 5:2:5:3.

937

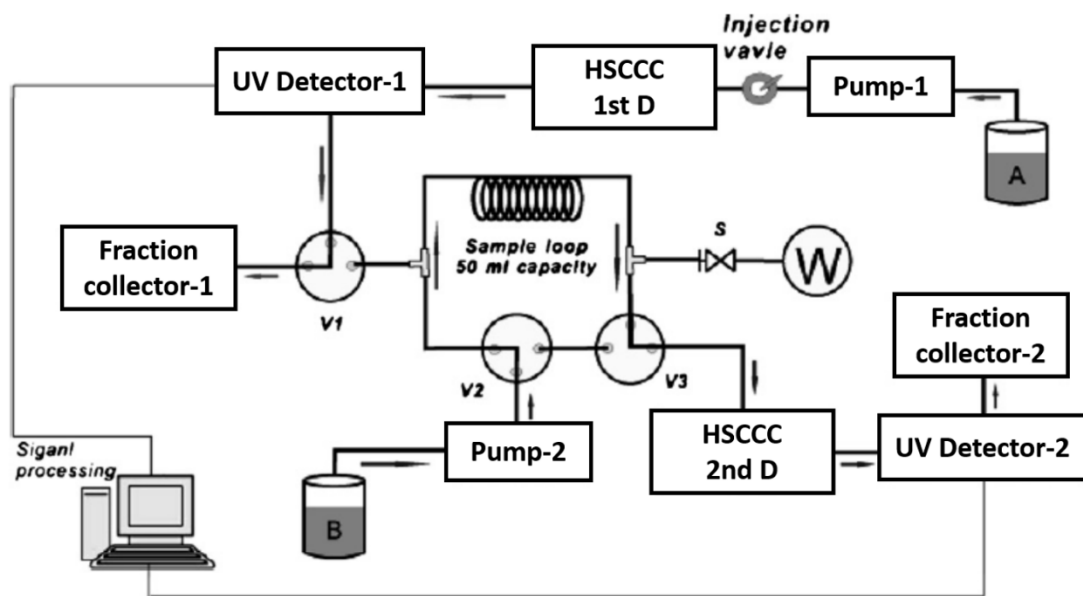

938
 939 Figure 5. Homemade column switching system interface used by Pan's group between ¹D LLC and ²D
 940 LLC. Modified from [37].

941
 942

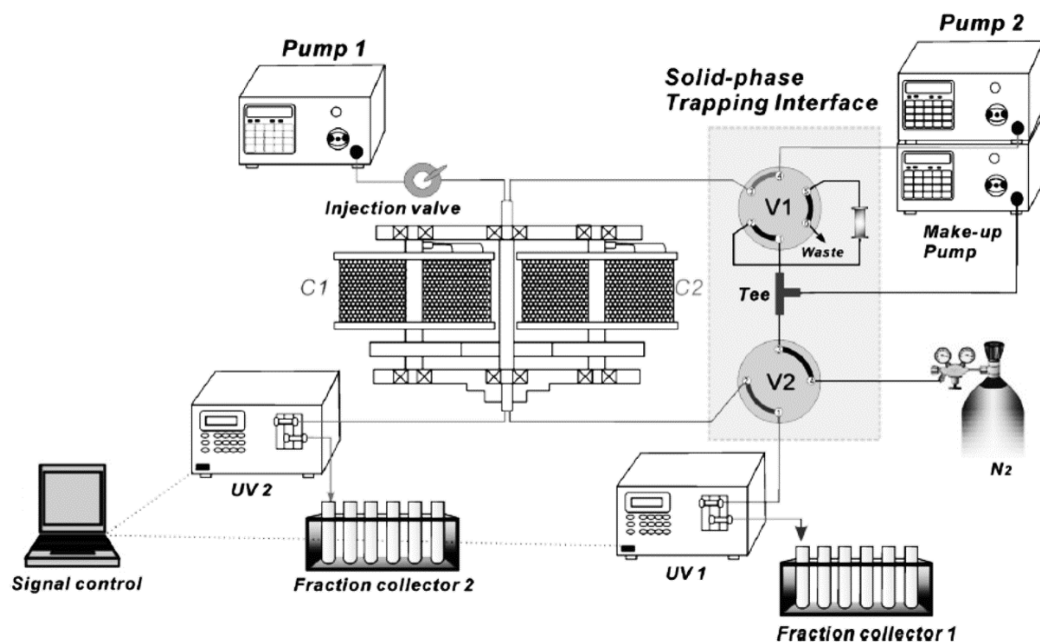

943
 944 Figure 6. Solid-phase trapping column interface used by Pan's group between ¹D LLC and ²D LLC.
 945 Modified from [40].

946

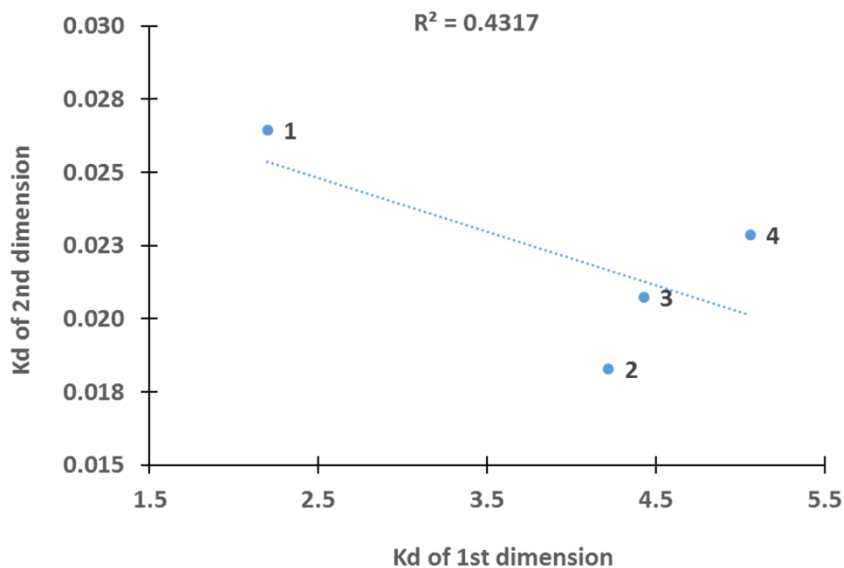

947

948 Figure 7. 2D orthogonality representation of a two dimensional LLC-LLC separation using solid-phase
 949 trapping columns interface. Data from reference [41]. ¹D solvent system: *n*-hexane/ethyl
 950 acetate/methanol/water 1:1:1:1 and ²D solvent system: methyl *tert*-butyl ether/acetonitrile/water
 951 2:2:3.

952

953

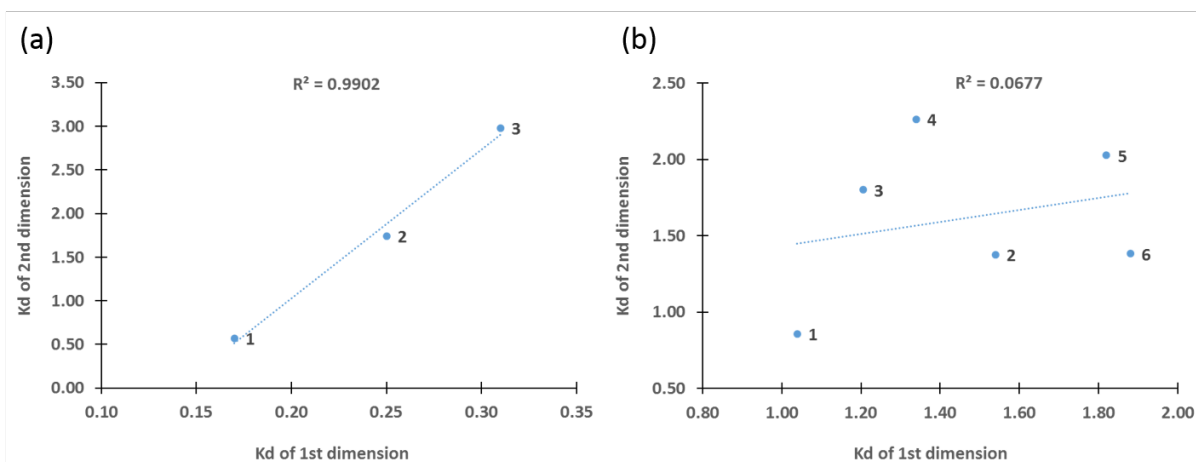

954

955 Figure 8. 2D orthogonality representations two dimensional LLC-LLC separations in offline mode: (a)
 956 ¹D solvent system: *n*-hexane/ethyl acetate/methanol/water 3:5:3:5 and ²D solvent system: ethyl
 957 acetate/*n*-butanol/water 7:3:10, data from [45]; (b) ¹D solvent system: petroleum ether/ethyl
 958 acetate/methanol/water 1:1:1:1 and ²D solvent system: petroleum ether/ethyl
 959 acetate/methanol/water+Cu²⁺ 1:1:1:1, data from [46].

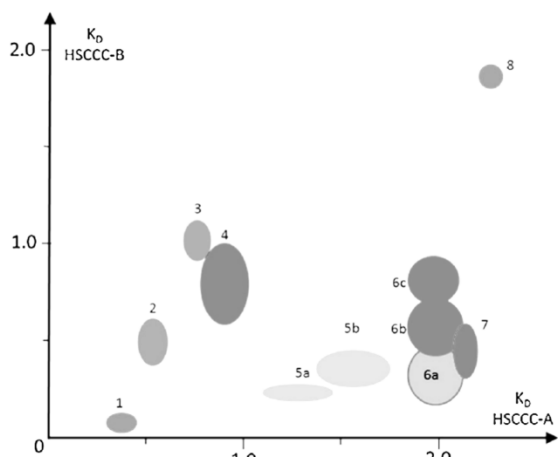

960

961 Figure 9. Experimental 2D-plot implemented in das Neves Costa et al. solvent system selection
 962 approach. Modified from [47].

963

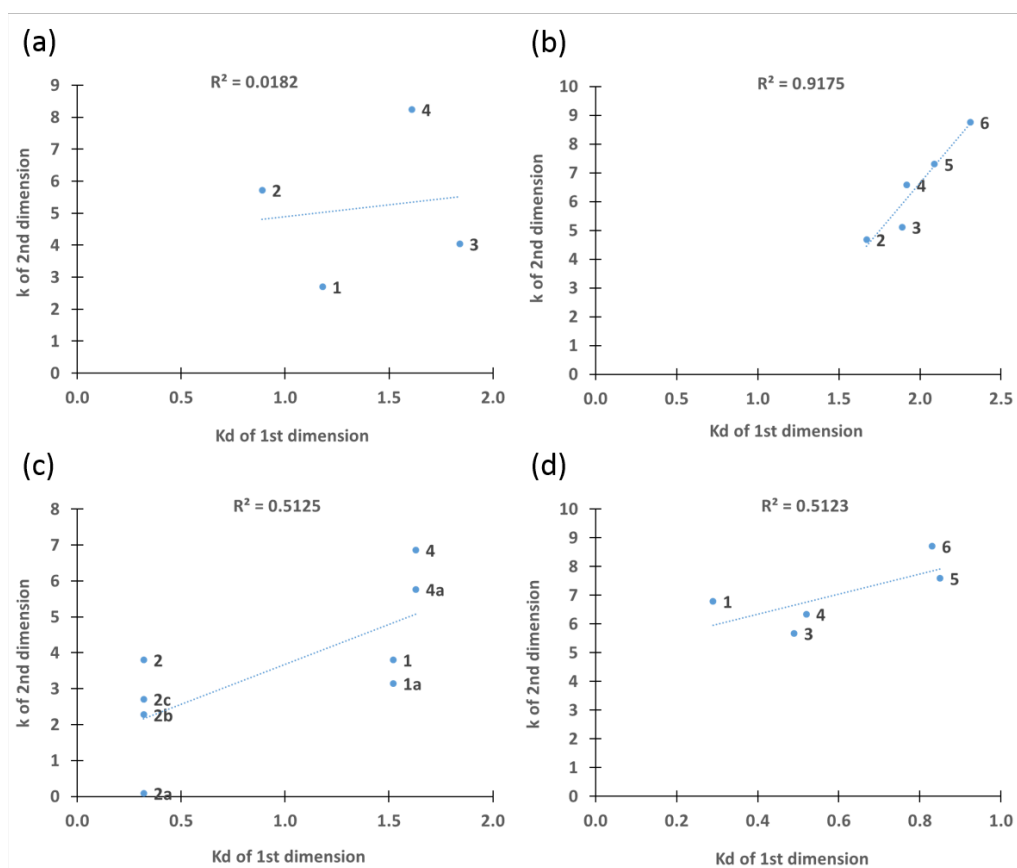

964

965 Figure 10. 2D orthogonality representations of offline LLC-HPLC two dimensional separations: (a) ¹D
 966 solvent system: *n*-hexane/ethyl acetate/methanol/water 6:4:5:5 and ²D system: C18 in
 967 methanol/water 60:40 isocratic mobile phase; Data from Zhu et al. [49]; (b) ¹D solvent system: *n*-
 968 hexane/ethyl acetate/methanol/water 1:1:1:1 and ²D system: ODS in acetonitrile/water 50:50 isocratic
 969 mobile phase; Data from Zhu et al. [53]; (c) ¹D solvent system: methyl ter-butyl ether/ethyl acetate/1-
 970 butanol/acetonitrile/modified water 1:3:1:1:5 and ²D system: ODS in methanol/water isocratic mobile
 971 phase; Data from Wang et al. [60] and (d) ¹D solvent system: ethyl acetate/*n*-butanol/water 0.5:4.5:5
 972 and ²D system: C18 in methanol/water isocratic mobile phase; Data from Chen et al. [57]

973

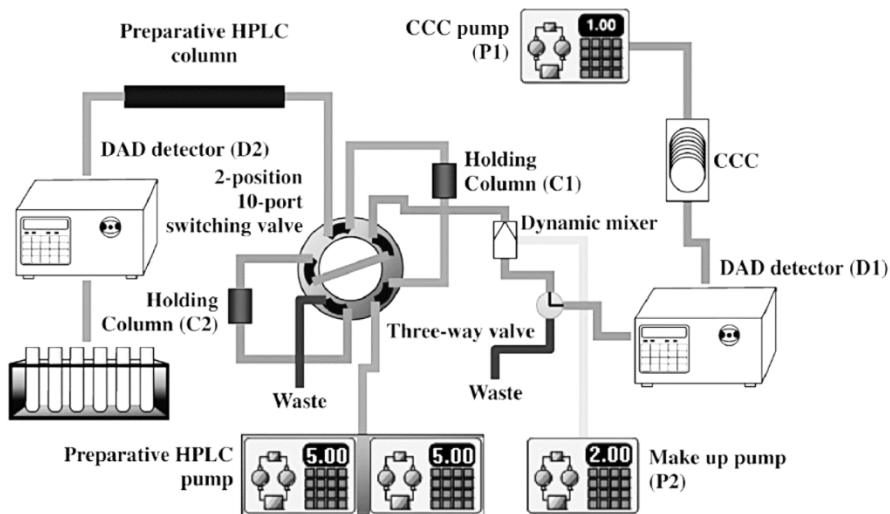

974

975 Figure 11. Solid-phase trapping columns interface between 1st dimensional LLC and 2nd dimensional
976 HPLC. Modified from [65].

977

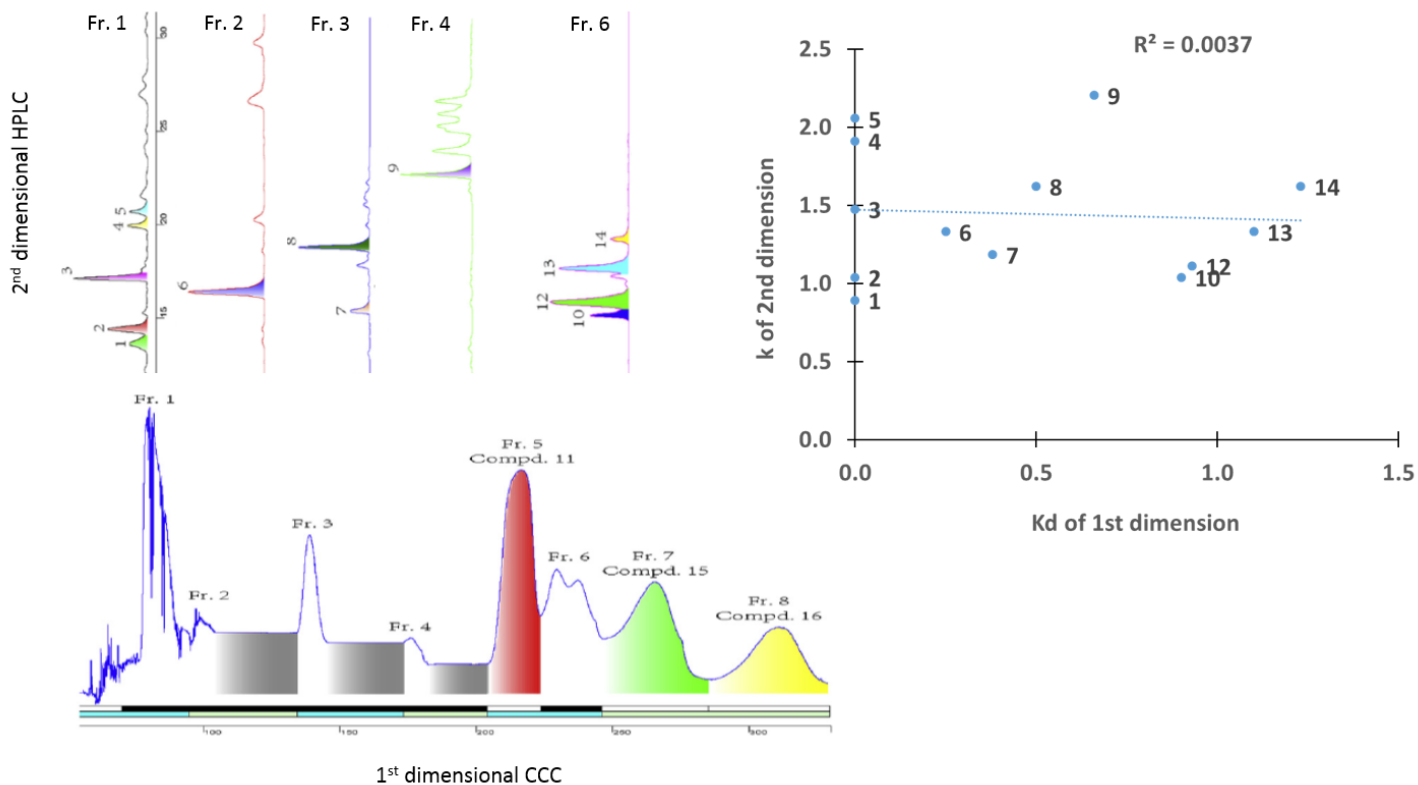

992 Figure 12. Two dimensional LLC-HPLC separation using solid-phase trapping columns interface and
993 stop-and-go mode [66] and its corresponding 2D orthogonality representation: ¹D solvent system: n-
994 heptane/acetone/water 31:50:19 and ²D system: C18 in methanol/water gradient as mobile phase.