



HAL
open science

Dripping to jetting transition for cross-flowing liquids

Aude Bertrandias, H. Duval, Joel Casalinho, Marie-Laurence Giorgi

► **To cite this version:**

Aude Bertrandias, H. Duval, Joel Casalinho, Marie-Laurence Giorgi. Dripping to jetting transition for cross-flowing liquids. *Physics of Fluids*, 2017, 29 (4), pp.044102. 10.1063/1.4979266 . hal-01510151

HAL Id: hal-01510151

<https://hal.science/hal-01510151v1>

Submitted on 19 Apr 2017

HAL is a multi-disciplinary open access archive for the deposit and dissemination of scientific research documents, whether they are published or not. The documents may come from teaching and research institutions in France or abroad, or from public or private research centers.

L'archive ouverte pluridisciplinaire **HAL**, est destinée au dépôt et à la diffusion de documents scientifiques de niveau recherche, publiés ou non, émanant des établissements d'enseignement et de recherche français ou étrangers, des laboratoires publics ou privés.

1 Dripping to jetting transition for cross-flowing liquids

2 A. Bertrandias,^{a)} H. Duval,^{b)} J. Casalinho, and M. L. Giorgi

3 *Laboratoire de Génie des Procédés et Matériaux (LGPM), CentraleSupélec, Université*
4 *Paris Saclay, Grande voie des vignes, 92295 Châtenay-Malabry, France*

5 Received and accepted dates, other relevant dates

6 We experimentally study drops formed from a nozzle into an immiscible, cross-
7 flowing phase. Depending on the operating conditions, drops are generated either in
8 dripping or jetting mode. We investigate the impact of the continuous and dispersed
9 phase velocities, dispersed phase viscosity and interfacial tension on the drop
10 generation mode and size. We find that a dripping to jetting transition (DJT) takes
11 place at a critical inner Weber number, function of the outer capillary and Ohnesorge
12 numbers. Two jetting regimes occur depending on the phase velocity ratio. When the
13 continuous phase velocity is significantly greater (resp. lower) than the dispersed
14 phase velocity, jet narrowing (resp. widening) occurs. In jet widening, the critical inner
15 Weber number depends little on the outer capillary number whereas in jet narrowing,
16 it sharply decreases as the outer capillary number increases. We propose a
17 comprehensive model to describe the DJT based on the attached drop equation of
18 motion. The model satisfactorily predicts the DJT and the effect of the outer capillary
19 number on the critical inner Weber number. It also well accounts for the drop diameter
20 in jet narrowing.

21 22 23 24 I. INTRODUCTION

25 Membrane emulsification is an industrial process used to generate emulsions by forcing a
26 dispersed phase through an inorganic, porous membrane into a continuous cross-flowing phase.¹ This
27 process is usually operated in dripping (drop by drop) mode. The shear stress exerted by the
28 continuous phase controls drop formation, so drag and the retaining capillary force are the main
29 forces involved. In dripping mode, the drop diameter decreases with increasing shear stress, while
30 remaining greater than the membrane pore size. A first estimate of the drop diameter may be given
31 by a simple torque balance about the pore edge.²

32 More recently, alternative fabrication methods based on microfluidics have appeared, such as
33 flow-focusing and coflowing devices. These devices commonly operate in dripping or jetting
34 (continuous jet) mode.³⁻⁶ In jetting mode, the liquid thread breaks up by Plateau-Rayleigh
35 instabilities. In certain operating conditions, drops much smaller than the nozzle diameter may be
36 produced. The same trend is expected for membrane emulsification operated in jetting mode. Thus,
37 it is of high interest to study the dripping to jetting transition (DJT) in this process.

38 A DJT can occur if the liquid thread exiting the nozzle grows to a length comparable to its radius
39 and if the pinch-off time is larger than the thread growth time.⁷ The simplest case is the dripping
40 faucet, where a dispersed phase flows from a nozzle into a stagnant, immiscible outer phase. Smith
41 and Moss⁸ studied mercury jets into gases and found that above a critical velocity (named the jetting
42 velocity), the liquid exits the nozzle as a jet. They proposed an empirical expression for the jetting
43 velocity, which can be recovered from a simple balance between the jet momentum flux and the
44 retaining capillary force. Scheele and Meister⁹ investigated the DJT for fifteen liquid-liquid couples
45 and established the jetting velocity from a force balance, which further includes the excess pressure
46 force. The maximum error between their data and predictions is of 30.2%. Richards *et al.*¹⁰ studied
47 drop formation before and after the DJT by computational fluid dynamics (CFD) and obtained drop
48 sizes that compare well with Scheele and Meister's data.⁹ Clanet and Lasheras¹¹ studied the DJT for
49 water flowing from a stainless steel nozzle into air and found that the DJT occurs at a critical inner
50 Weber number We_{in} function of Bond numbers (Bo , Bo_o). We_{in} compares the inner momentum to
51 the capillary force. It is built with the nozzle inner diameter and mean dispersed phase velocity in the

^{a)} Electronic mail: aude.bertrandias@centralesupelec.fr

^{b)} Electronic mail: herve.duval@centralesupelec.fr

1 nozzle. Bo and Bo_o compare buoyancy to the retaining capillary force. Bo (resp. Bo_o) is built with
2 the nozzle inner (resp. outer) diameter. When the dispersed phase does not wet the nozzle, only Bo
3 is relevant. Clanet and Lasheras¹¹ extended Taylor's model¹² for the recession of a free, liquid edge.
4 Their model, adapted to drop recession and growth, predicts the jetting velocities. Their calculations
5 are in good agreement with their own data and Scheele and Meister's data⁹ (maximum error of 13.7%
6 and 20%, resp.).

7 In coflowing liquids, Cramer *et al.*¹³ examined the critical continuous phase velocity for the
8 DJT. They found that it decreases for increasing dispersed phase flow rates or viscosity ratios
9 $\zeta = \eta_{dp}/\eta_{cp}$ and for decreasing interfacial tensions. Utada *et al.*³ proposed a state diagram of the
10 DJT in coflowing liquids in a $Ca_{out}-We_{in}$ space. Ca_{out} compares the viscous force (exerted by the
11 outer fluid) to the capillary force. It is built with the nozzle inner diameter, the outer (continuous)
12 phase viscosity and velocity. Two jetting regimes occur depending on the fluid velocity ratio. If the
13 outer velocity is greater than the inner one, the inner liquid is stretched by the outer fluid and jet
14 narrowing occurs. If the outer velocity is lower than the inner one, the outer fluid slows the inner
15 fluid and jet widening occurs.^{3,4} In jet widening, Castro-Hernández *et al.*⁴ showed that inertial or
16 viscous forces drove the DJT depending on the inner Reynolds number Re_{in} (built with the mean
17 dispersed phase velocity and nozzle inner diameter). They proposed a unified scaling to predict drop
18 size in both the widening and narrowing regimes (relative errors of 30%). Chen *et al.*¹⁴ studied both
19 regimes by CFD. They noted that drop detachment in jet widening is due to high pressures in the
20 neck whereas in jet narrowing, it is due to velocity differences between the front and rear ends of the
21 neck (linking the drop to the thread).

22 Two spatiotemporal instabilities may occur in coflowing liquids: an absolute instability (A),
23 with disturbances advected up- and downstream or a convective instability (C), with advection only
24 downstream.^{15,16} Linear stability analysis was performed for confined coflowing liquids. Concentric
25 cylindrical capillaries¹⁷ and rectangular channels¹⁸ were studied at low Reynolds numbers. Analysis
26 was extended to when liquid inertia is not negligible.¹⁹ A/C regions were typically provided as a
27 function of the inner and outer phase flow rates. The A (resp. C) region coincides with the dripping
28 (resp. jetting) region identified experimentally. Stability analysis was also performed for unbounded
29 coflowing liquids: jet widening was reported as absolutely unstable and jet narrowing as convectively
30 unstable. The widening regime was actually assimilated to a dripping regime, with drops formed at
31 the end of the fluid thread.²⁰

32 Compared to coflowing liquids, the DJT in membrane emulsification (*i.e.*, for cross-flowing
33 liquids) was very little investigated: Meyer and Crocker²¹ performed experiments whereas Pathak²²
34 examined the DJT by CFD. For both, membrane emulsification was mimicked by forcing a dispersed
35 phase through a single, circular pore of a plane wall sheared by a continuous phase flow. Meyer and
36 Crocker²¹ found that the state diagram of the DJT depends on We_{in} and Ca_{out} , but also on the inner
37 Ohnesorge number Oh_{dp} (ratio of the viscocapillary to inertial-capillary time scale). Both authors
38 proposed a correlation for the DJT by replacing Bo and Bo_o by Ca_{out} in Clanet and Lasheras' DJT
39 criterion¹¹ and by adjusting coefficients. However, no comprehensive models were developed in this
40 configuration.^{21,22}

41 The aim of this work is to study drop generation in cross-flow. The setup consists in a nozzle,
42 which forms dispersed phase drops into a continuous cross-flowing phase. Both dripping and the
43 DJT are studied for various phase velocities, interfacial tensions and dispersed phase viscosities.
44 Dripping data are used to identify the drag force experienced by a drop attached to the nozzle. Then,
45 a physical model is proposed to predict the jetting velocities and drop diameters at the DJT. This
46 enables to gain insight on drop formation in membrane emulsification and more generally on the DJT
47 for cross-flowing liquids.

49 II. EXPERIMENTAL

50 The systems investigated are reported in Table I. For the reference system, the continuous and
51 dispersed phases are distilled water and dodecane, respectively. For systems 1 and 2, a surfactant
52 (Sodium dodecyl sulfate, SDS) is added to the continuous aqueous phase to study the effect of the
53 interfacial tension. We note that the SDS concentration of system 1 (resp. 2) is lower (resp. greater)
54 than the critical micellar concentration (CMC) of SDS in water, *i.e.* 2 g.L^{-1} . For both systems, a good

1 estimate of the interfacial tension when drops form is given by the value of the dynamic interfacial
 2 tension at the intermediate plateau.^{23,24} This value is greater than the equilibrium value. For system
 3 2, we consider that micelles have no specific impact on the process examined: surfactant essentially
 4 modifies the intermediate plateau value. Last, for systems 3 and 4, paraffin is added to dodecane to
 5 study the effect of the dispersed phase viscosity.

6 We note γ the interfacial tension, ρ_{dp} and ρ_{cp} the dispersed and continuous phase densities,
 7 respectively, and η_{dp} and η_{cp} the dispersed and continuous phase viscosities. γ was measured for
 8 all systems by the rising drop method, with a tensiometer (Tracker, I.T. Concept, Teclis). η_{dp} was
 9 measured at 25.1°C, with a Ubbelohde viscosimeter (AVS310, Schött-Gerade).

10 TABLE I: Investigated system composition and physicochemical properties. Reproduced from A. Bertrandias, H. Duval, J.
 11 Casalinho and M. L. Giorgi, Phys. Fluids, 28, 102103 (2016), with the permission of AIP Publishing.

System and symbol	Dispersed phase	η_{dp} (mPa.s)	ρ_{dp} (kg.m ⁻³)	Continuous phase	η_{cp} (mPa.s)	ρ_{cp} (kg.m ⁻³)	γ (mN.m ⁻¹)
Reference (\diamond)	Dodecane	1.34	750	Distilled water	0.89	997	50.7 \pm 3.5 ^a
1 (\blacklozenge)	Dodecane	1.34	750	Distilled water and SDS (0.1 wt%)	0.89	997 \pm 1.4 ^a	22.3 \pm 0.5 ^{a,b}
2 (\blacklozenge)	Dodecane	1.34	750	Distilled water and SDS (2 wt%)	0.89	1001 \pm 1.2 ^a	6.6 \pm 0.2 ^{a,b}
3 (\blacktriangleleft)	Dodecane (75 wt%) and paraffin (25 wt%)	1.79 \pm 0.23 ^a	772 \pm 1.2 ^a	Distilled water	0.89	997	53.5 \pm 2.4 ^a
4 (\blacktriangleright)	Dodecane (50 wt%) and paraffin (50 wt%)	3.24 \pm 0.42 ^a	790 \pm 1.1 ^a	Distilled water	0.89	997	50.0 \pm 1.2 ^a

12 The tabulated values ^a are measured experimentally; ^b correspond to those at the intermediate plateau.

13
 14 An original setup was designed (Fig. 1). It consists in a cell with a horizontal channel through
 15 which the continuous phase flows. A vertical nozzle of inner diameter $D_p = 0.32$ mm emerges into
 16 the channel. The continuous phase is pumped in a closed cycle by a gear pump (MDG M15T3B,
 17 Iwaki Co.), perpendicular to the nozzle axis (cross-flow). The flow rate is adjusted (OVAL MIII
 18 LSF41, OVAL Corporation) with a 0.1 L.h⁻¹ precision. The dispersed phase is forced through the
 19 nozzle with a syringe pump (PHD ULTRA, Harvard Apparatus) at a volumetric flow rate q_{dp}
 20 (accuracy $\leq 0.25\%$), giving a mean dispersed phase velocity in the nozzle v_{dp} . A cold light (KL
 21 2500 LCD, Schott) illuminates the setup. A high-speed camera (v310, Phantom) allowing up to 3250
 22 fps at full resolution (1280 \times 800 px²) is mounted with a macro lens (Macro MP-E 65mm f/2.8,
 23 Canon) of magnification $\times 5$. Images are captured through the cell windows and are analysed with
 24 ImageJ to obtain data such as drop size D_d , with the scale (238 px/mm) set by the nozzle outer
 25 diameter (433 \pm 2 μ m). Average relative standard deviations in drop diameters are of 3.4%, 8.7%
 26 and 7.7% in dripping, jet widening and narrowing, respectively.

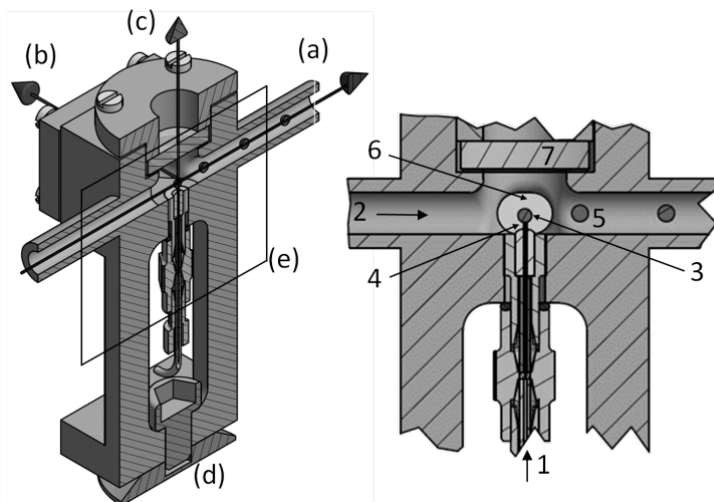

27
 28 FIG. 1: Cell cross-section by CAD (to scale). Cell (left): (a) continuous phase flow axis; (b) optical axis; (c) dispersed
 29 phase flow axis; (d) cell binding point; (e) frame for zoom. Zoom in the cell (right): 1, dispersed phase inlet (microfluidic

1 system); 2, continuous phase flow; 3, growing drop; 4, nozzle; 5, formed drop carried away; 6, optical glass window; 7:
 2 window for user.

3
 4 In order to obtain the so-called unperturbed continuous phase velocity at the location of the
 5 bound drop center of mass (denoted v_{cp}), the continuous phase flow is analyzed by particle image
 6 velocimetry (PIV), without dispersed phase injection (see supplementary material A, Fig. A1).
 7 Analysis is performed for the range of continuous phase volumetric flow rates q_{cp} tested in this work.
 8 The average continuous phase velocity is essentially uniform above the nozzle except in a thin
 9 adjacent layer (see supplementary material A, Fig. A2). We theoretically estimate the boundary-layer
 10 thickness at a distance $D_p/2$ from the leading edge of the nozzle²⁵ for all q_{cp} and find a thickness of
 11 0.06 mm for the highest q_{cp} to 0.2 mm for the lowest q_{cp} : the boundary-layer thickness is always
 12 small compared to the minimum drop diameter formed at the given q_{cp} (0.302 mm and 1.019 mm,
 13 resp.). The drop is thus mainly located above the shear layer that develops above the nozzle. This
 14 differs from Meyer and Crocker's²¹ or Pathak's²² work, where the drop is entirely located in the shear
 15 flow set up by the continuous phase flowing parallel to the plane wall. In the following, the
 16 continuous phase velocity v_{cp} seen by a growing drop corresponds to the velocity measured in the
 17 uniform flow above the shear layer.

18 Drop formation by dripping is studied as a function of the continuous phase velocity v_{cp} seen
 19 by the growing drop. The parameters tested are reported in Table II (dripping trials). We consider
 20 that the Reynolds number characteristic of the continuous phase flow in the channel inside the cell is
 21 close to the Reynolds number in the cylindrical tubes on the sides of the cell, in series with this
 22 channel (see Fig. 1). We find $Re = 4\rho_{cp}q_{cp}/\pi D_t\eta_{cp}$ from 330 to 3300, with D_t the tube diameter.
 23 According to Morrison²⁵, the continuous phase flow entering the cell is laminar ($Re < 2100$) or
 24 transitional ($2100 < Re < 3300$). The inner Reynolds number $Re_{in} = 4\rho_{dp}q_{dp}/\pi D_p\eta_{dp}$ ranges
 25 from 2 to 38, so the dispersed phase flow is laminar in the nozzle.

26 Then, the DJT is studied. The v_{cp} values tested are given in Table II (DJT trials) and the
 27 dispersed phase velocity v_{dp} is increased slowly until the DJT. The onset of jetting is defined as in
 28 the literature^{21,22}: it occurs when $L_n/D_d > 1$, with L_n the thread length prior to drop break off (from
 29 the nozzle surface to the drop base) and D_d the detached drop diameter. We obtain jetting velocities
 30 with a precision of 2.9 to 7.7% in jet widening and 2.6 to 11.1% in jet narrowing (due to the chosen
 31 increment in dispersed phase flux). We note that these velocities correspond to a transition from
 32 dripping to jetting. For the transition from jetting to dripping, the value may vary due to hysteresis
 33 phenomena.¹¹ Re_{in} ranges from 7 to 130, so the dispersed phase flow is laminar in the nozzle. In the
 34 tubes on the sides of the cell, Re ranges from 330 to 6600, so for the highest q_{cp} , *i.e.* v_{cp} , the
 35 continuous phase flow is turbulent in the channel.²⁵

36 TABLE II: Operating conditions investigated.

System	Dripping trials		DJT trials
	v_{cp} (m.s ⁻¹)	v_{dp} (m.s ⁻¹)	v_{cp} (m.s ⁻¹)
Reference	0.18 - 0.55	0.016, 0.031, 0.063, 0.14, 0.21	0.17 - 1.03
1	0.11 - 0.50	0.031	0.17 - 0.59
2	0.10 - 0.40	0.031	0.17 - 0.40
3	0.11 - 0.55	0.031	0.23 - 1.03
4	0.10 - 0.60	0.031	0.23 - 0.94

37
 38 After a series of trials (either PIV or dripping and DJT trials), the cell is filled with 3 vol%
 39 Mucosol (Merz) for 24h and is rinsed with distilled water. The nozzle surface is then hydrophilic: the
 40 organic dispersed phase does not wet the nozzle surface, so its outer diameter does not impact drop
 41 generation.

43 III. DROP GENERATION BY DRIPPING WITH CROSS-FLOW

44 Drop diameters D_d were measured as a function of the continuous phase velocity v_{cp} (Fig. 2),
 45 at constant $v_{dp} = 0.031$ m.s⁻¹. As v_{cp} increases, D_d decreases due to the increasing shear exerted by

1 the continuous phase flow. Drop diameters scale as $v_{cp}^{-0.62}$ to $v_{cp}^{-0.80}$, depending on the system. A
 2 lower interfacial tension γ leads to smaller drops (systems 1 and 2, Fig. 2). The capillary force
 3 decreases with γ , so a drop detaches earlier, also found by Xu *et al.*²⁶ No significant impact on D_d is
 4 seen with the dispersed phase viscosity η_{dp} (possibly a slight decrease in D_d with increasing η_{dp})
 5 (Fig. 2). In membrane emulsification, Timgren *et al.*²⁷ numerically found a decrease in drop size with
 6 a thousand-fold increase in η_{dp} , expected as the drag coefficient then notably increases.²⁸ In our case,
 7 the difference may not be large enough to significantly impact drop size.

8 The influence of v_{dp} was also tested on the reference system (not shown). We find that v_{dp}
 9 does not impact drop diameter, as found for a stationary outer phase²⁹ or in cross-flow²⁶. For these
 10 trials, drops form in dripping mode. $Ca_{out} = \eta_{cp}v_{cp}/\gamma$ ranges from 3.1×10^{-3} to 9.7×10^{-3} , $We_{in} =$
 11 $\rho_{dp}D_p v_{dp}^2/\gamma$ from 1.1×10^{-3} to 2.0×10^{-1} and $Oh_{dp} = \eta_{dp}/\sqrt{\rho_{dp}D_p\gamma} = 1.2 \times 10^{-2}$. This is in fact in the
 12 dripping region of the state diagram reported in the literature.^{21,22}

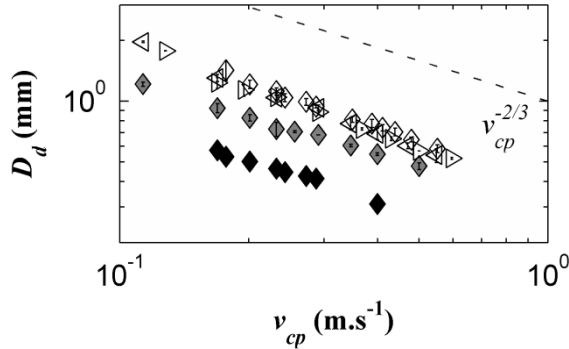

13 FIG. 2: Drop diameter D_d function of the continuous phase velocity v_{cp} , $v_{dp} = 0.031 \text{ m.s}^{-1}$. See Table I for symbols.

14
 15
 16 In order to account for the drop diameter scaling observed in dripping mode, we consider that
 17 drag and the retaining capillary force are the main forces involved. Buoyancy is neglected since the
 18 buoyancy to drag force ratio is on average less than 5%. As Peng and Williams², we assume that the
 19 drop subjected to the forces discussed above stays spherical and rotates about the nozzle edge until
 20 detachment. The fraction of the drop that could remain attached to the nozzle tip after break off is
 21 neglected. The torque balance (TB) about the nozzle edge reads:

$$22 \quad \frac{\pi D_d^2}{4} C_D \frac{\rho_{cp}}{2} v_{cp}^2 \frac{D_d}{2} = \pi D_p \gamma \frac{D_p}{2} \quad (1)$$

23 with C_D the drag coefficient. In Eq. (1), we neglect the velocity of the drop center of mass v_d . Indeed,
 24 if we assume that in dripping mode, the main contribution to the drop center of mass motion is due
 25 to drop growth, a rough estimate of v_d is given by $v_d(t) \approx 0.5(dD_d/dt)$, where D_d increases in
 26 time according to $D_d(t) = (6qt/\pi)^{1/3}$. For all systems and phase velocities tested, we find $v_d \ll$
 27 v_{cp} (38 to 589 times). We further rearrange Eq. (1) as:

$$28 \quad \frac{D_d}{D_p} = k \left(\frac{Oh_{cp}}{Ca_{out}} \right)^{2/3} \quad (2)$$

29 with $k = [8/C_D]^{1/3}$ and $Oh_{cp} = \eta_{cp}/\sqrt{\rho_{cp}D_p\gamma}$ the outer Ohnesorge number. We note that Eq. (2)
 30 may also be written as $D_d/D_p = k We_{out}^{-1/3}$, with We_{out} the outer Weber number, built with the
 31 continuous phase velocity. If we assume that C_D is approximately constant (corresponding to the
 32 Newton regime), from Eq. (2), we find that the drop diameter scales as $v_{cp}^{-2/3}$. This is in good
 33 agreement with our experimental data ($v_{cp}^{-0.62}$ to $v_{cp}^{-0.80}$). However, this scaling differs from the one
 34 found by Meyer and Crocker²¹, *i.e.* $D_d/D_p \sim Ca_{out}^{-1/2}$. In their trials, drops are entirely located in the
 35 shear layer that develops along the plane wall and their diameters seem better described by a force
 36 balance.

37 For a solid sphere in an infinite fluid, the Newton regime holds for particle Reynolds numbers
 38 $Re_p = \rho_{cp}v_{cp}D_d/\eta_{cp}$ from 10^3 to 10^5 .²⁵ In this range, $C_D \approx 0.4$. In our case, $Re_p = 92$ to 360 , so C_D

1 may vary. We estimate C_D from Eq. (1) and find that C_D decreases with increasing Re_p (data points,
 2 Fig. 3). Our C_D values are higher than reported for a viscous sphere in an infinite fluid by Feng and
 3 Michaelides³⁰ (dashed line, Fig. 3). Indeed, in our trials, the drop is not isolated but bound to a nozzle.
 4 We propose to model the variations of C_D as a function of Re_p by the law of Eq. (3), in the form
 5 obtained by Abraham³¹ for a solid sphere:

$$6 \quad C_D = C_0 \left(1 + \frac{\delta_0}{Re_p^{1/2}} \right)^2 \quad (3)$$

7 We perform a weighted least squares minimization to identify the free coefficients of Eq. (3)
 8 from the data of the reference system, systems 1 and 2. These systems are characterized by a viscosity
 9 ratio $\zeta = 1.5$, with $Re_p = 92$ to 360. We find $C_0 = 0.14$ and $\delta_0 = 17.7$. The data are well described
 10 by the adjusted law (solid line, Fig. 3). In the Stokes limit ($Re_p \ll 1$), Eq. (3) reads $C_D \approx$
 11 $C_0 \delta_0^2 / Re_p \approx 45 / Re_p$ close to the drag coefficient of a solid sphere at a wall in creeping flow, *i.e.*
 12 $C_D \approx 1.7 \times (24 / Re_p) \approx 41 / Re_p$.³² We only retain that the order is satisfactory as our drop deviates
 13 from a solid sphere and the coefficients were adjusted far from the Stokes regime.

14 For system 3 ($\zeta = 2.0$) and 4 ($\zeta = 3.6$), we cannot carry out the above method since our trials
 15 do not cover a wide range of Re_p for these viscosity ratios. We assume that C_D are not significantly
 16 different than from Eq. (3) fitted on systems with $\zeta = 1.5$, consistently with the analysis of Fig. 2. In
 17 Section IV, Eq. (3) will be used to estimate the drag force experienced by a drop near the DJT.

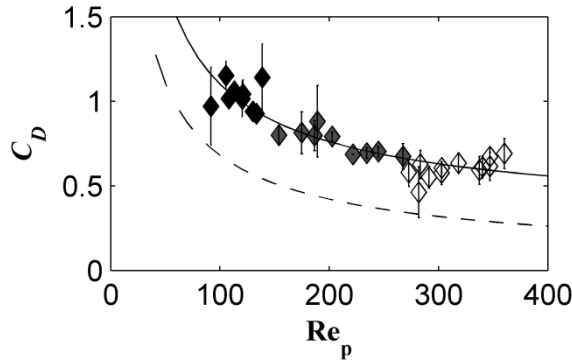

18 FIG. 3: Drag coefficient C_D function of the particle Reynolds number Re_p . Experimental results from Eq. (1), see Table I
 19 for symbols. Feng and Michaelides predictions for $\zeta = 1.5$ (dashed line); our fit from Eq. (3) with $C_0 = 0.14$ and $\delta_0 = 17.7$
 20 (solid line).
 21
 22

23 IV. DRIPPING TO JETTING TRANSITION (DJT)

24 A. Experimental results

25 For a set system and continuous phase velocity v_{cp} , the DJT is reached for a critical dispersed
 26 phase velocity (corresponding to the jetting velocity for the given v_{cp}). We remind that the onset of
 27 jetting is defined when the length of the liquid thread connecting the drop to the nozzle reaches the
 28 drop diameter (see Section II). Typical snapshots of dripping and jetting are reported in Fig. 4. We
 29 note that in Fig. 4(a) and (b), the first image on the left represents “strict” dripping (as studied in
 30 Section III), with a drop rotating about the nozzle edge.

31 As in coflowing liquids,^{3,4,14} when the DJT is reached, two jetting regimes may be observed.
 32 When $v_{cp} \lesssim v_{dp}$, the liquid thread is on average thicker than the nozzle inner diameter (Fig. 4(a),
 33 last image): this is the widening regime. On the contrary, when $v_{cp} \gtrsim v_{dp}$, the liquid thread gets
 34 thinner from the nozzle to the drop (Fig. 4(b), last image): this is the narrowing regime. Curiously,
 35 Meyer and Crocker²¹ did not distinguish these regimes in their paper.

36 In jet widening, we also see that the thread undergoes surface oscillations (see supplementary
 37 material B, Fig. B1). These oscillations are essentially stationary in space. According to Utada *et*
 38 *al.*²⁰ who studied jet widening in coflowing liquids, this behavior is characteristic of an absolute
 39 instability. To quantify this, as Utada *et al.*²⁰, we examine the variations of the neck diameter
 40 (between the thread and growing drop) as a function of time (see supplementary material B, Fig. B2).
 41 The neck diameter oscillates about its mean with an increasing amplitude until pinch off and

1 subsequent drop detachment. The oscillation frequency is around 350 Hz for the reference system,
 2 consistent with the inertial-capillary time scale of this system.

3 As for coflowing or cross-flowing liquids^{3,21,22}, we represent the DJT in the $Ca_{out}-We_{in}$ space.
 4 We remind that We_{in} is the inner Weber number ($We_{in} = \rho_{dp} D_p v_{dp}^2 / \gamma$) and Ca_{out} the outer
 5 capillary number ($Ca_{out} = \eta_{cp} v_{cp} / \gamma$). Figure 5(a) presents the variations of We_{in} built with the
 6 jetting velocity as a function of Ca_{out} , for the five systems of Table II. The curves exhibit a plateau
 7 for lower Ca_{out} values and a sudden decrease for higher Ca_{out} . They are similar in shape to the
 8 curves established by Meyer and Crocker²¹ and Pathak.²² We associate the plateau with jet widening
 9 and the sudden decrease with jet narrowing. For all systems, at the plateau, We_{in} is in the order of 1,
 10 in the order of magnitude reported for jet widening in coflow.³ Our plateau values are also similar to
 11 those of Meyer and Crocker²¹ and Pathak.²² The transition between widening and narrowing occurs
 12 at a critical value of Ca_{out} , such that $v_{cp} \approx v_{dp}$. This value is denoted Ca^* for the reference system
 13 in Fig. 5(a).

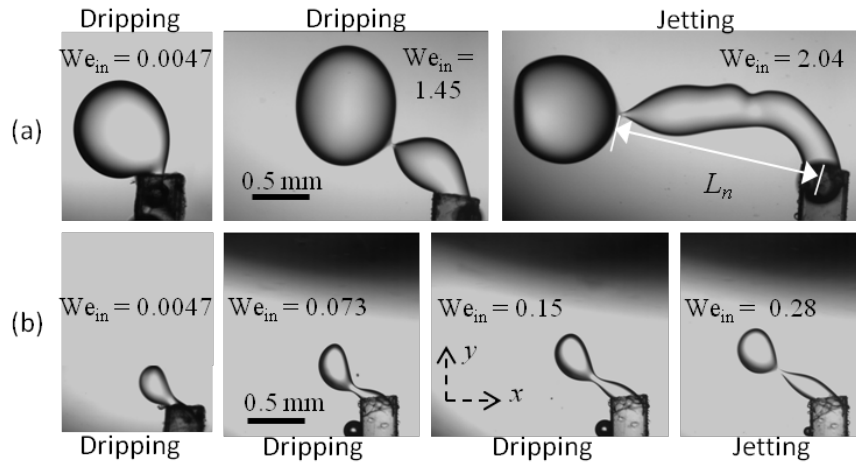

14
 15 FIG. 4: Reference system snapshots ($Oh_{cp} = 7.0 \times 10^{-3}$): (a) jet widening, $Ca_{out} = 5.1 \times 10^{-3}$; (b) jet narrowing, $Ca_{out} =$
 16 1.3×10^{-2} . Continuous phase flow from right to left.

17
 18 The same trends, *i.e.* a plateau followed by a marked decrease, are obtained for the drop
 19 diameters formed at the DJT as a function of Ca_{out} (Fig. 5(b)). The variations in drop diameters at
 20 the DJT as a function of Ca_{out} were not reported before.^{21,22} In jet widening, we expect that the drop
 21 diameter is controlled by a balance between the jet momentum and the retaining capillary force. In
 22 jet narrowing, the drop diameter should be controlled by a balance between the drag force
 23 experienced by the drop and the capillary force. As the continuous phase velocity increases, the
 24 thread gets thinner leading to a lower retaining capillary force, thus smaller drops.

25 As the interfacial tension γ decreases between the reference system, system 1 and 2, the plateau
 26 value for We_{in} decreases and the transition from jet widening to narrowing is shifted towards higher
 27 Ca_{out} . This result, to which we shall return, was not reported before. The influence of γ on the DJT
 28 was not examined in detail in cross-flow.^{21,22}

29 In our trials, the dispersed phase viscosity η_{dp} does not affect the jetting velocity since the data
 30 for the reference system, system 3 and 4 collapse onto a unique curve (Fig. 5(a)). This is in good
 31 agreement with Meyer and Crocker's results.²¹ They found that the jetting velocity does not vary
 32 significantly with the inner Ohnesorge number $Oh_{dp} = \eta_{dp} / \sqrt{\rho_{dp} D_p \gamma}$ while Oh_{dp} is below 3×10^{-2} .
 33 Indeed, while $Oh_{dp} \ll 1$, the pinch-off time scale is in the order of the inertial-capillary time scale,
 34 thus it does not depend on η_{dp} . This corresponds to our experimental range: Oh_{dp} increases from
 35 1.2×10^{-2} to 2.9×10^{-2} as η_{dp} increases from 1.34 to 3.24 mPa.s. Drop diameters are also unaffected by
 36 η_{dp} (Fig. 5(b)).

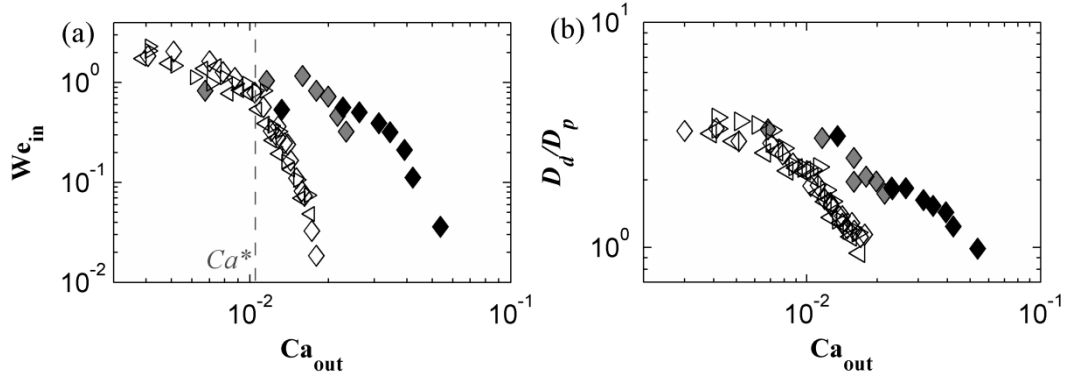

FIG. 5: Characteristic values at the DJT, see Table I for symbols: (a) We_{in} function of Ca_{out} . Widening to narrowing limit Ca^* for the reference system (dashed line); (b) Drop to pore diameter ratio D_d/D_p function of Ca_{out} .

According to Utada *et al.*³ and Meyer and Crocker²¹, our DJT curves should overlap in the $Ca_{out}-We_{in}$ space since $Oh_{dp} \ll 1$. However, as stated before, our DJT curves are shifted towards higher Ca_{out} as the interfacial tension decreases. We attribute this to the hydrodynamic regime of the drag force experienced by a growing drop. Indeed, the particle Reynolds number Re_p ranges from 114 to 424 in our DJT trials. These values are much higher than those reported by Utada *et al.*³ and Meyer and Crocker.²¹ Thus, the drag force in our trials rather corresponds to the Newtonian regime than to the Stokes regime. Since the ratio of the drag to capillary force is in the order of $(Ca_{out}/Oh_{cp})^2 = We_{out}$ under Newton regime assumption (as opposed to Ca_{out} under Stokes approximation), we plot We_{in} as a function of Ca_{out}/Oh_{cp} (see supplementary material C). We remind that Oh_{cp} is the outer Ohnesorge number ($Oh_{cp} = \eta_{cp}/\sqrt{\rho_{cp}D_p\gamma}$). We find that reference system and system 1 and 2 data then actually collapse in the narrowing regime.

B. Model

The DJT criteria proposed by Pathak²² and Meyer and Crocker²¹ are not adapted to our case. Indeed, in our trials, the growing drops are mainly located above the shear layer adjacent to the nozzle tip (see Section II) and the particle Reynolds number is far from the Stokes regime (see Section IV.A). Figure D1 (supplementary material D) shows the discrepancy between our DJT data for the reference system and previous authors' DJT criteria.^{21,22} We remind that these criteria are semi-empirical since these authors simply replaced Bo and Bo_o , the Bond numbers built with the nozzle inner and outer diameters, by Ca_{out} in Clanet and Lasheras' criterion¹¹ and adjusted the coefficients to fit their data. In this section, we propose a comprehensive model to account for the jetting velocity and drop diameters at the DJT.

Firstly, the footage shows that thread dynamics occur essentially along the x -axis (Fig. 4): the drop forms at the end of a thread that tends to align with the continuous phase flow. Thus, we approximate our configuration by a coflow configuration (Fig. 6). A force balance is now more relevant than a torque balance since the drop can no longer be considered as a sphere rotating about the nozzle edge.

We revisit Clanet and Lasheras' approach¹¹ developed for a liquid injected downwards into a stagnant gas under gravity and amend the drop equation of motion to consider coflowing liquids. We thus add a drag force induced by the continuous flowing phase since η_{cp} is orders of magnitude higher than the dynamic viscosity of air and we account for the added mass effect since $\rho_{cp} \sim \rho_{dp}$. We neglect buoyancy since for the largest drops (obtained in the widening regime), the buoyancy to capillary force ratio is lower than 3%.

In Clanet and Lasheras' scenario¹¹, drops are generated as follows: a first drop detaches (at $x = 0$ in Fig. 6), leaving a thread behind that recedes at a velocity dx/dt , due to surface tension effects. During recession, a mass (drop) M forms (sphere in Fig. 6). It recedes until it reaches a distance x_{max} (closer to the nozzle, Fig. 6). The mass then progresses the other way, once momentum and drag overcome surface tension effects. It is assumed that pinch off begins at x_{max} . From that point, the drop no longer grows. The drop travels a distance l_d until detachment. If $x_{max} > l_d$, dripping occurs. Oppositely, if $x_{max} < l_d$, the detachment point advances each time, leading to jetting.

1 The mass $M(t)$ of the drop is given by

$$2 \quad M(t) = \frac{\pi}{4} D_p^2 \rho_{dp} v_{dp} t + \rho_{dp} \int_0^{x(t)} S_{th}(x') dx' \quad (4)$$

3 We remind that v_{cp} and v_{dp} are velocity moduli. $S_{th}(x)$ is the thread cross-section at the location x .
 4 $S_{th}(x)$ is related to $v_{th}(x)$, the mean fluid velocity modulus in the thread at the location x , by $q_{dp} =$
 5 $S_{th}(x)v_{th}(x)$. The variations of the mean dispersed phase velocity v_{th} along the thread depend on
 6 the continuous phase shear stress.

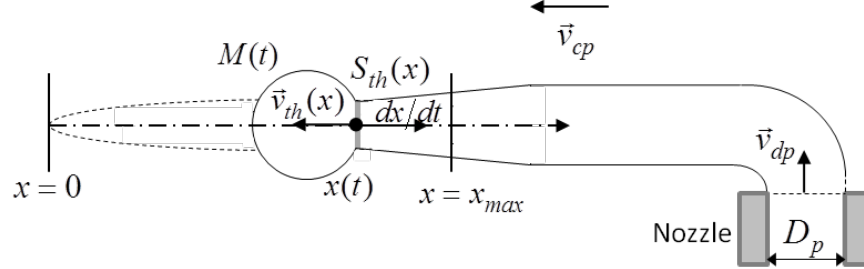

7
 8 FIG. 6: Model configuration with the different variables involved.

9 The drop equation of motion during recession reads:

$$10 \quad \frac{d}{dt} \left[(M(t) + M_a(t)) \frac{dx}{dt} \right] = \pi D_{th}(x) \gamma - \rho_{dp} q_{dp} \left(\frac{dx}{dt} + v_{th}(x) \right) - \frac{\pi}{4} D_m^2(t) C_D \frac{\rho_{cp}}{2} \left(v_{cp} + \frac{dx}{dt} \right)^2 \quad (5)$$

11 The left-hand side of Eq. (5) corresponds to the drop effective inertia and includes $M_a(t)$ the added
 12 mass due to the surrounding continuous phase. We suppose that the added mass is equal to half of
 13 the displaced volume of continuous phase, as for a solid sphere in an infinite medium. It is thus given
 14 by $M_a(t) = 0.5M(t)\rho_{cp}/\rho_{dp}$. The first term on the right-hand side of Eq. (5) is the retaining
 15 capillary force, with $D_{th}(x)$ the thread diameter at the location x . The second term is the jet
 16 momentum flux entering the drop. The last term is the drag force, in which the frontal area
 17 corresponds to that of a sphere with the given mass. The drop mass diameter is given by:

$$18 \quad D_m(t) = \left[\frac{6 M(t)}{\pi \rho_{dp}} \right]^{1/3} \quad (6)$$

19 In the drag force, the drag coefficient $C_D(\text{Re}_p)$ is estimated from Eq. (3), with the coefficients adjusted
 20 before and Re_p is built with $D_m(t)$ (Eq. (6)) and the relative velocity $|v_{cp} + dx/dt|$. At the DJT, we
 21 find $\text{Re}_p = 114$ to 424 (estimated with the experimental D_d and v_{cp}). This is in the same range as
 22 where the coefficients of Eq. (3) were adjusted. However, Eq. (3) was established for drops detaching
 23 in dripping mode: we here neglect the deviations in C_D that may arise at the DJT when the thread
 24 linking the drop to the nozzle is larger. We assume that C_D essentially depends on the drop mass
 25 diameter and the particle Reynolds number and little on the drop shape details.

26 x_{max} is determined from the numerical integration of system (4-6) (see Appendix). As stated
 27 above, the DJT occurs at $x_{max} = l_d$. l_d is the detachment distance by pinch off, such that:

$$28 \quad \int_0^{l_d} \frac{dx}{v_{th}(x)} = \tau_n \quad (7)$$

29 τ_n is the necking time or pinch-off time (in the order of the inertial-capillary time), given by:

$$30 \quad \tau_n = k' \left[\frac{D_j^3(x_{max}) \rho_{dp}}{8\gamma} \right]^{1/2} \quad (8)$$

31 We estimate $k' \approx 8.26 \pm 0.43$ by Clanet and Lasheras' method¹¹: we measure the neck diameter
 32 variations in dripping mode as a function of time during pinch off, we fit the variations to an
 33 exponential form to find τ_n and we plot $1/\tau_n$ as a function of $\tau_c = [8\gamma/D_p^3\rho_{dp}]^{1/2}$. This was done
 34 for the reference system, systems 1 and 2 (see supplementary material E). These systems differ only
 35 by their interfacial tension and are characterized by a viscosity ratio $\zeta = 1.5$. We find τ_n 2.6 times

1 higher than Clanet and Lasheras¹¹ for a liquid in air, which depicts a lower instability growth rate.
 2 This is in agreement with results reported in the literature: Rayleigh³³ found a growth rate (made
 3 dimensionless by τ_c) of 0.34 for an inviscid liquid in air. On the other hand, Funada and Joseph³⁴
 4 found a growth rate 1.3 to 4.8 times lower for water in benzene ($\zeta = 1.5$) in the range of our Re_{in} ,
 5 from a fully viscous analysis.

6 Returning to the model, the jetting velocity at a set v_{cp} is obtained as follows (see Appendix for
 7 details): v_{dp} is scanned and for each v_{dp} , the system (4-6) is integrated as a function of time, until
 8 $x = x_{max}$. If x_{max} coincides with l_d (Eq. (7)), the corresponding v_{dp} value is the jetting velocity at
 9 the given v_{cp} . The resulting drop diameter is deduced from Eq. (6): $D_d \approx D_m(t_{max})$, where t_{max} is
 10 the time taken for the mass to travel from 0 to x_{max} . This method may be repeated for each v_{cp} tested
 11 to reproduce our experimental results.
 12

13 C. Comparison with experiments

14 To implement the above model, we must describe the mean dispersed phase velocity along the
 15 thread. Two limit cases will be considered: (1) the thread diameter and mean velocity are negligibly
 16 affected by the continuous phase flow in both jetting regimes and (2) the mean thread velocity quickly
 17 reaches the continuous phase velocity in the narrowing regime.

18 C.1. Uniform nozzle-sized thread

19 First, we consider the simplest scenario where the thread diameter is not affected by the
 20 continuous phase in either jetting regime. In this case, we assume $v_{th}(x) = v_{dp}$ and $D_{th}(x) = D_p$
 21 from $x = 0$ to x_{max} . Then, the thread cross-section reads $S_{th}(x) = \pi D_p^2/4$. We call this the uniform
 22 nozzle-sized thread limit. We solve system (4-6) under this assumption by the method described in
 23 the Appendix. The results are reported in Fig. 7 (solid lines).

24 The variations of the critical inner Weber number We_{in} function of the outer capillary number
 25 Ca_{out} are satisfactorily reproduced (Fig. 7(a), solid lines). The same conclusion may be drawn for
 26 the variations of the dimensionless drop diameter as a function of Ca_{out} (Fig. 7(b), solid lines).
 27 Furthermore, the effect of the interfacial tension on the transition is well accounted for.

28 The model predicts a plateau in jet widening (for small Ca_{out}), but in our experiments, the
 29 plateau is more pronounced and extends for higher Ca_{out} . Furthermore, in jet widening, We_{in} and
 30 especially D_d are overpredicted. The difference in plateau values for We_{in} between the reference
 31 system and system 2 is also not reproduced (Fig. 7(a)). We checked that the differences in plateau
 32 values cannot be attributed to the relative effect of buoyancy. We attribute them to the thread surface
 33 oscillations (see supplementary material B), which affect the retaining capillary force and pinch-off
 34 time. These oscillations cannot be accounted for in the framework of the present model.

35 Lastly, we note that We_{in} and D_d are overestimated at high Ca_{out} for the reference system (and
 36 systems 3 and 4, not shown in Fig. 7). This may be explained by the narrowing of the thread which
 37 becomes significant at high v_{cp} but is neglected in the present case. In the next section (IV.C.2), we
 38 attempt to take this effect into account.

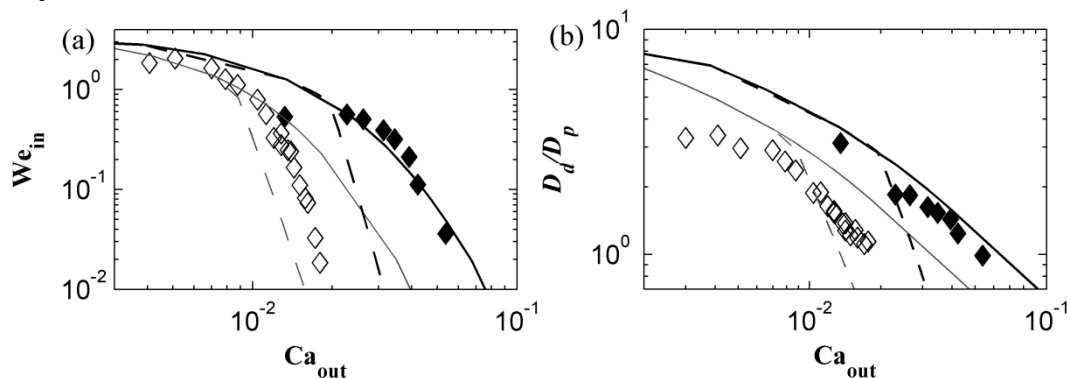

39
 40 FIG. 7: Characteristic values at the DJT, see Table I for symbols. (a) We_{in} function of Ca_{out} . (b) Drop to pore diameter
 41 ratio D_d/D_p function of Ca_{out} . Simulation results for the reference system (grey); system 2 (black). Uniform nozzle-sized
 42 thread limit of Section IV.C.1 (solid line); maximal narrowing limit of Section IV.C.2 (dashed line).
 43

44 C.2. Maximal narrowing

1 We measure the thread diameter for the reference system in the narrowing regime: it decreases
 2 by less than 10% for $v_{cp} \leq 0.73 \text{ m}\cdot\text{s}^{-1}$ ($\text{Ca}_{\text{out}} = 1.3 \times 10^{-2}$) but decreases by more than 50% for the
 3 highest v_{cp} . In the latter case, narrowing effects can no longer be neglected and our hypothesis
 4 $D_{th}(x) = D_p$ of Section IV.C.1 is no longer valid.

5 We suppose that the momentum diffusion across the thread is rapid and fully efficient in the
 6 narrowing regime. In this case, we may consider that if $v_{cp} > v_{dp}$, the thread is characterized by
 7 $v_{th}(x) = v_{cp}$, $D_{th}(x) = D_p(v_{dp}/v_{cp})^{1/2}$ and $S_{th}(x) = \pi D_{th}^2(x)/4$ from $x = 0$ to x_{max} . This
 8 gives the maximal narrowing limit. According to Castro-Hernandez *et al.*⁴, maximal narrowing is
 9 observed when $\text{Re}_{\text{in}} < 1$. In our trials, $\text{Re}_{\text{in}} = 7$ to 130, so their assumption is not strictly applicable.
 10 However, it will give us an overestimate of the narrowing effect on the DJT and drop diameter. If
 11 $v_{cp} < v_{dp}$ (jet widening), we still neglect the effect of the continuous phase on the thread size and
 12 assume that $D_{th}(x) = D_p$ and $v_{th}(x) = v_{dp}$, as in Section IV.C.1.

13 As before, we solve system (4-6) under these new assumptions (see Appendix) and we report
 14 the results in Fig. 7 (dashed lines). For the reference system (and systems 3 and 4, not shown), our
 15 data for We_{in} and D_d in jet narrowing lie in between the maximal narrowing limit (dashed lines, Fig.
 16 7(a) and (b)) and the uniform nozzle-sized thread limit (solid lines, Fig. 7(a) and (b)).

17 We note that the data for system 2 are surprisingly well described by the uniform nozzle-sized
 18 thread limit. This is probably due to the compensation of different errors related to the uniform
 19 nozzle-sized approximation, the use of the drag coefficient estimated in the dripping regime and the
 20 assumption that forces act only along the x -axis.

21 V. CONCLUSIONS

22 While the dripping to jetting transition (DJT) is well documented for liquid-air^{8,11} or liquid-
 23 liquid coflow^{3,4,13,14}, liquid-liquid cross-flow^{21,22} has received little attention and no comprehensive
 24 model was proposed to describe the DJT in this configuration. Also, drop diameters specifically at
 25 the DJT were either not measured or not reported.^{21,22}

26 In the present work, we studied liquid-liquid cross-flow for different phase velocities, interfacial
 27 tensions and dispersed phase viscosities. Contrary to previous work^{21,22}, the growing drops are mainly
 28 located above the shear layer that develops above the nozzle. Furthermore, since the inner Ohnesorge
 29 number (characteristic of the dispersed phase flow) is much lower than 1, drop pinch-off is controlled
 30 by the inertial-capillary time scale.

31 In strict dripping, we found that the drop diameter is well described by a simple torque balance
 32 about the nozzle edge, taking into account the drag force experienced by the drop and the retaining
 33 capillary force. This result was used to estimate the drag coefficient for an attached drop as a function
 34 of the particle Reynolds number.

35 The DJT occurs at a critical inner Weber number function of the outer capillary and Ohnesorge
 36 numbers. Two jetting regimes occur (widening and narrowing) depending on the phase velocity ratio.
 37 In jet widening (when the dispersed phase velocity is greater than the continuous phase one), the
 38 critical inner Weber number depends little on the outer capillary number whereas in the narrowing
 39 regime, it sharply decreases as the outer capillary number increases. Furthermore, when the outer
 40 Ohnesorge number increases, the transition between widening and narrowing is shifted to higher
 41 values of the outer capillary number. The hydrodynamic regime of the drag force experienced by a
 42 growing drop is actually inertial and not viscous.

43 We proposed to model the DJT in liquid-liquid cross-flow by revisiting an approach originally
 44 developed by Clanet and Lasheras for a liquid injected into a stagnant gas under gravity. The model
 45 describes the recession dynamics and the growth of the drop until pinch off. In the present case, the
 46 driving force for drop detachment is not buoyancy but the drag force exerted by the continuous phase
 47 flow. We distinguished two limit cases for the thread profile that exits the nozzle and enters the drop:
 48 a uniform nozzle-sized thread limit and a maximal narrowing limit. Jetting velocities and drop
 49 diameters measured at the DJT in jet narrowing are well accounted for and lie in between model
 50 predictions in the two limit cases. Furthermore, the effect of the outer Ohnesorge number on the DJT
 51 is well reproduced. In jet widening, the agreement is less satisfactory. Discrepancies are attributed to
 52 thread surface oscillations which appear in jet widening. However, we may conclude that the main
 53

1 features of the DJT in cross-flow are captured which highlights the insight and the robustness of
2 Clanet and Lasheras' original model.

3 4 **SUPPLEMENTARY MATERIAL**

5 See supplementary material for insight on: A, continuous phase flow analysis using Particle
6 Image Velocimetry (PIV); B, oscillations in jet widening; C, collapsed data in jet narrowing; D,
7 comparison with Pathak's and Meyer and Crocker's DJT criteria; E, estimation of the necking time.

8 **ACKNOWLEDGEMENTS**

9 We thank T. Martin and J. Trubuil for their contribution in designing the setup and for their
10 work on the setup manufacturing.

11 **APPENDIX: NUMERICAL METHOD TO OBTAIN THE JETTING VELOCITY**

12 For a set v_{cp} , the jetting velocity is obtained by an iterative procedure. v_{dp} is varied with a 0.001
13 m.s⁻¹ increment. For each v_{dp} value, the recession dynamics of a growing drop is computed by
14 integrating system (4-6) using the fourth order Runge-Kutta method. The initial conditions are
15 $D_d(0) = 0$ and $x(0) = 0$. According to Eq. (5), $\dot{x}(0)$ is then given by Eq. (A1) for the uniform
16 nozzle-sized thread limit and by Eq. (A2) for the maximal narrowing limit.

$$17 \quad \dot{x}(0) = -\frac{v_{dp}}{2} \left(1 + \frac{\rho_{dp}}{\rho_e}\right) + \frac{1}{2} \left(v_{dp}^2 \left(1 - \frac{\rho_{dp}}{\rho_e}\right)^2 + \frac{16\gamma}{D_p \rho_e} \right)^{1/2} \quad (A1)$$

$$18 \quad \dot{x}(0) = -\frac{v_{cp}}{2} \left(1 + \frac{\rho_{dp}}{\rho_e}\right) + \frac{1}{2} \left(v_{cp}^2 \left(1 - \frac{\rho_{dp}}{\rho_e}\right)^2 + \frac{16\gamma(v_{dp}/v_{cp})^{1/2}}{D_p \rho_e} \right)^{1/2} \quad (A2)$$

19 with $\rho_e = \rho_{dp} + \rho_{cp}/2$. Integration is performed until the drop stops and changes direction. That
20 point is denoted x_{max} . The above iterative procedure is stopped as soon as $x_{max} = l_d$, the latter
21 calculated from Eq. (7). At this point, the v_{dp} value corresponds to the jetting velocity.

22
23 ¹ T. Nakashima, M. Shimizu and M. Kukizaki, "Membrane Emulsification by Microporous Glass," Key Eng. Mat. **61-62**, 513
24 (1992).

25 ² S. J. Peng and R. A. Williams, "Controlled production of emulsions using a crossflow membrane: Part I: Droplet formation from a
26 single pore," Chem. Eng. Res. Des. **76** (8), 894 (1998).

27 ³ A. Utada, A. Fernandez-Nieves, H. Stone and D. Weitz, "Dripping to Jetting Transitions in Coflowing Liquid Streams," Phys. Rev.
28 Lett. **99** (9), 094502 (2007).

29 ⁴ E. Castro-Hernández, V. Gundabala, A. Fernández-Nieves and J. M. Gordillo, "Scaling the drop size in coflow experiments," New
30 J. Phys. **11** (7), 075021 (2009).

31 ⁵ A. M. Gañán-Calvo, "Jetting-dripping transition of a liquid jet in a lower viscosity co-flowing immiscible liquid: the minimum
32 flow rate in flow focusing," J. Fluid Mech. **553** (1), 75 (2006).

33 ⁶ S. L. Anna, N. Bontoux and H. A. Stone, "Formation of dispersions using "flow focusing" in microchannels," Appl. Phys. Lett. **82**
34 (3), 364 (2003).

35 ⁷ A. S. Utada, "Monodisperse Double Emulsions Generated from a Microcapillary Device," Science **308** (5721), 537 (2005).

36 ⁸ S. W. J. Smith and H. Moss, "Experiments with Mercury Jets," Proc. R. Soc. Math. Phys. Eng. Sci. **93** (652), 373 (1917).

37 ⁹ G. F. Scheele and B. J. Meister, "Drop formation at low velocities in liquid-liquid systems: Part II. Prediction of jetting velocity,"
38 AIChE J. **14** (1), 15 (1968).

39 ¹⁰ J. R. Richards, A. N. Beris and A. M. Lenhoff, "Drop formation in liquid-liquid systems before and after jetting," Phys. Fluids **7**
40 (11), 2617 (1995)

41 ¹¹ C. Clanet and J.C. Lasheras, "Transition from dripping to jetting," J. Fluid Mech. **383**, 307 (1999).

42 ¹² G. I. Taylor, "The dynamics of thin sheets of fluids. III. Disintegration of fluid sheets," Proc. R. Soc. Lond. A **253**, 313 (1959).

43 ¹³ C. Cramer, P. Fischer and E. J. Windhab, "Drop formation in a co-flowing ambient fluid," Chem. Eng. Sci. **59** (15), 3045 (2004).

1 ¹⁴ Y. Chen, L. Wu and C. Zhang, “Emulsion droplet formation in coflowing liquid streams,” *Phys. Rev. E* **87** (1), 013002 (2013).

2 ¹⁵ S. J. Leib and M. E. Goldstein, “Convective and absolute instability of a viscous liquid jet,” *Phys. Fluids* **29** (4), 952 (1986).

3 ¹⁶ P. Huerre and P. A. Monkewitz, “Local and Global Instabilities in Spatially Developing Flows,” *Annu. Rev. Fluid Mech.* **22** (1),

4 473 (1990).

5 ¹⁷ P. Guillot, A. Colin, A. S. Utada and A. Ajdari, “Stability of a Jet in Confined Pressure-Driven Biphasic Flows at Low Reynolds

6 Numbers,” *Phys. Rev. Lett.* **99** (10), 104502 (2007).

7 ¹⁸ P. Guillot, A. Colin and A. Ajdari, “Stability of a jet in confined pressure-driven biphasic flows at low Reynolds number in

8 various geometries,” *Phys. Rev. E* **78** (1), 016307 (2008).

9 ¹⁹ M. A. Herrada, A. M. Gañán-Calvo and P. Guillot, “Spatiotemporal instability of a confined capillary jet,” *Phys. Rev. E* **78** (4),

10 046312 (2008).

11 ²⁰ A. S. Utada, A. Fernandez-Nieves, J. M. Gordillo and D. A. Weitz, “Absolute Instability of a Liquid Jet in a Coflowing Stream,”

12 *Phys. Rev. Lett.* **100** (1), 014502 (2008).

13 ²¹ R. F. Meyer and J. C. Crocker, “Universal Dripping and Jetting in a Transverse Shear Flow,” *Phys. Rev. Lett.* **102**, 194501 (2009).

14 ²² M. Pathak, “Numerical simulation of membrane emulsification: Effect of flow properties in the transition from dripping to

15 jetting,” *J. Membr. Sci.* **382** (1–2), 166 (2011).

16 ²³ S. R. Deshiikan, D. Bush, E. Eschenazi and K. D. Papadopoulos, “SDS, Brij58 and CTAB at the dodecane-water interface,”

17 *Colloids and Surfaces A: Physicochem. Eng. Aspects* **136**, 133 (1998).

18 ²⁴ A. Bertrandias, H. Duval, J. Casalinho and M. L. Giorgi, “Drop generation from a vibrating nozzle in an immiscible liquid-liquid

19 system,” *Phys. Fluids* **28**, 102103 (2016).

20 ²⁵ F. A. Morrison, *An introduction to fluid mechanics* (Cambridge University Press, 2013), pp. 622–694.

21 ²⁶ J. Xu, G. Luo, G. Chen and J. Wang, “Experimental and theoretical approaches on droplet formation from a micrometer screen

22 hole,” *J. Membr. Sci.* **266** (1–2), 121 (2005).

23 ²⁷ A. Timgren, G. Trägårdh and C. Trägårdh, “Effects of cross-flow velocity, capillary pressure and oil viscosity on oil-in-water drop

24 formation from a capillary,” *Chem. Eng. Sci.* **64** (6), 1111 (2009).

25 ²⁸ R. Clift, J. Grace and M. E. Weber, *Bubbles, Drops and Particles* (Dover Publications, Inc., 2005) pp.125–135.

26 ²⁹ A. Bertrandias, H. Duval, J. Casalinho and M. L. Giorgi, “Good vibrations —Transition in drop generation from an immersed

27 capillary tube,” *EPL* **111** (4), 44004 (2015).

28 ³⁰ Z.-G. Feng and E. E. Michaelides, “Drag Coefficients of Viscous Spheres at Intermediate and High Reynolds Numbers,” *J. Fluids*

29 *Eng.* **123** (4), 841 (2001).

30 ³¹ F. F. Abraham, “Functional Dependence of Drag Coefficient of a Sphere on Reynolds Number,” *Phys. Fluids* **13** (8), 2194 (1970).

31 ³² M. E. O’Neill, “A sphere in contact with a plane wall in a slow linear shear flow,” *Chem. Eng. Sci.* **23** (11), 1293 (1968).

32 ³³ Rayleigh, “On the instability of jets,” *Proceeding Lond. Math. Soc.* **10**, 4 (1878).

33 ³⁴ T. Funada and D. D. Joseph, “Viscous potential flow analysis of capillary instability,” *Int. J. Multiph. Flow* **28** (9), 1459 (2002).

34