



HAL
open science

Process simulation and life cycle analysis in the dairy industry – application to milk concentration

Martial Madoumier, Catherine Azzaro-Pantel, Geneviève Gésan-Guiziou

► To cite this version:

Martial Madoumier, Catherine Azzaro-Pantel, Geneviève Gésan-Guiziou. Process simulation and life cycle analysis in the dairy industry – application to milk concentration. Les sciences du génie des procédés pour une industrie durable, Société Française de Génie des Procédés, Oct 2013, Lyon, France. hal-01497416

HAL Id: hal-01497416

<https://hal.science/hal-01497416>

Submitted on 28 Mar 2017

HAL is a multi-disciplinary open access archive for the deposit and dissemination of scientific research documents, whether they are published or not. The documents may come from teaching and research institutions in France or abroad, or from public or private research centers.

L'archive ouverte pluridisciplinaire **HAL**, est destinée au dépôt et à la diffusion de documents scientifiques de niveau recherche, publiés ou non, émanant des établissements d'enseignement et de recherche français ou étrangers, des laboratoires publics ou privés.



Distributed under a Creative Commons Attribution 4.0 International License

Process simulation and life cycle analysis in the dairy industry – application to milk concentration

Martial Madoumier^{a,b,c,1}, Catherine Azzaro-Pantel^c, Geneviève Gésan-Guiziou^{a,b}

^aINRA, UMR1253 Science et Technologie du Lait et de l'Œuf, F-35042 Rennes, France

^bAGROCAMPUS OUEST, F-35042 Rennes, France

^cLaboratoire de Génie Chimique, UMR5503 CNRS, Université de Toulouse, ENSIACET INPT/UPS, BP 84234, F-31432 Toulouse, France

Keywords: dairy industry; optimisation; environmental analysis; concentration process.

Abstract

Milk concentration and spray drying are highly energy-intensive operations, for which energy consumption accounts for about 25% of the French dairy processing industry. A major challenge consists then in the design and development of sustainable dairy concentration processes which integrate technical, economic and environmental criteria. For this purpose, systems oriented tools have already been developed in the chemical industry by using a systemic approach combining modelling, simulation, and optimisation. Despite the proximity of chemical with food and bioengineering sectors, the utilization of such an approach for the modelling of dairy processes suffers from a lack of process models, more particularly when the whole process is considered and when concentration processes are involved. In that context, this work constitutes a preliminary study towards the development of a methodological framework for modelling and optimizing dairy processes. The proposed strategy consists in the combination of a chemical process simulator (ASPEN PLUS 7.3, AspenTech, Inc.) with an environmental model based on Life Cycle Assessment concepts. The simulated process concerns milk powder production, and more particularly milk concentration prior to drying, involving pre-heating, pasteurization, and evaporation steps. The process model performances are assessed through a sensitivity study on the number of effects in the evaporator, and the environmental impacts associated to the various steam requirements involved are quantified according to several scenarios.

1. Introduction

The design and development of sustainable food processes, which integrate technical and economic criteria, satisfy customer demands, and are less harmful to ecosystems constitutes a major challenge in a context of global changes (climate change, energy scarcity and energy price increase). An interesting way to meet these constraints entails a systemic approach combining process modelling, simulation, and optimisation. Although methodological tools have been developed in the chemical industry (Steffens et al., 1999, Azapagic et al., 2011, Ouattara et al., 2012), the development of this approach in the food sector suffers from a lack of available and applicable food process models (Trystram, 2012).

In the dairy industry, concentration can, together with drying, be considered as the most energy intensive operations. Concentration is used to increase the dry matter of dairy products before their transformation (cheese or powder manufactures) and reduce flows inside dairy factories and for transportation. Concentration can be performed by evaporation and filtration. Evaporation is mainly achieved using falling film evaporators, in which the dairy product passes through steam-heated tubes under vacuum and is brought to a boiling temperature between 40-75°C. In order to decrease energy demand, multi-stage falling film evaporators are mostly used. They consist of a series of calandria, in which the water evaporates from the dairy product at one stage and is subsequently used as heating source for the next stage.

Despite improvements of the process, the concentration and drying steps consume nowadays about 25% of the total energy used in the dairy processing (French Ministry of agriculture, Agreste, 2011). This

¹ Corresponding author : martial.madoumier@rennes.inra.fr

suggests that heat recovery opportunities and/or technological breakthroughs must be investigated to improve the situation.

In that context, this work is devoted to the development of a methodological framework for modelling and optimizing dairy concentration processes using process systems engineering concepts that have been used for long for the design and optimization of chemical processes (Jeantet et al., 2007 & 2011, Banga et al., 2003). It must be emphasized that several process simulators such as ASPEN PLUS, Aspen Hysys, ProSim Plus, Pro/II, and COCO, are widely used in the process industries to compute mass and energy balances. But despite the proximity of chemical with food and bioengineering sectors, the utilization of such generic process simulators for the modelling of dairy processes is scarce in the literature (Bon et al., 2010, Cheng and Friis, 2007, Diefes et al., 2000, Ribeiro and Andrade, 2003). This is all truer as the whole process is considered and concentration processes are involved (Diefes et al., 2000, Ribeiro and Andrade 2003).

The paper is focused on the presentation of the approach combining a dairy process model with the use of the ASPEN PLUS simulation software tool with an environmental impact assessment method based on Life Cycle Assessment (LCA) performed with SIMAPRO and the EcoInvent database (EcoInvent Centre, 2012).

The case study concerns a milk concentration system using a steam-fed evaporator as a part of a milk powder production plant. It was first studied and simulated in Ribeiro (2001), Ribeiro and Andrade (2003), mostly for process performance analysis with varying milk inlet temperature and motive steam pressure. This process will serve as a test bench to validate the approach and the simulation runs will be used to study the influence of the number of evaporator effects on steam requirements, i.e. environmental performance.

2. Strategy, methods and tools

2.1. Milk modelling

The ASPEN PLUS simulator was chosen for process simulation for this study, because of its substantial unit operation models library, and its strong capacity to integrate and model components that are not included in its built-in database.

A first requirement in the process simulator physical properties system concerns the identification of milk. Milk cannot be described as a standard chemical compound, since it is identified as a complex mixture of about 2000 different components. This explains why modelling milk as a non-conventional component in ASPEN PLUS is a convenient solution: only its density and heat capacity need to be specified, and its evaporation is performed with user models. This solution has already been used (Ribeiro, 2001, Ribeiro and Andrade, 2003) for milk characterization but is also used for other complex substances such as coal or biomass. Milk is described as a mixture of conventional components representing its five categories of components: cow water, i.e. the water vapour separated from milk (its properties are close to pure water), milk fat, proteins, carbohydrates (mostly lactose), and ashes (minerals).

The concentration process is simulated through the evaporation of the cow water component. The thermodynamic properties of the four categories of soluble solids are based on data from NREL (Wooley and Putsche, 1996) and on the models from Choi and Okos (1986), so that the mixture properties will match the properties of “real” milk. The milk heat capacity is evaluated by the correlation proposed by Minim et al. (2002) which is valid in a large range of temperatures and mass fractions. It is a function of temperature (T in K), water (WC in mass fraction), and fat (FC in mass fraction) contents expressed on a mass fraction basis (w/w):

$$C_p = 1.4017 + 0.0021 \cdot T - 1.7430 \cdot FC + 2.1816 \cdot WC \text{ (in J/g.K)}$$

2.2 Flowsheet description

Figure 1 presents the flowsheet of the milk concentration process used in the dairy plant of Embaré Indústrias Alimentícias S.A. in Brazil that was widely studied in Ribeiro (2001), Ribeiro and Andrade (2003).

The unit operations consist in two pre-heaters E-101 and E-102, a pasteurization unit PA-101 fed with hot water by a tank T-101 (modelled as a heat exchanger), a stabilizing tank T-102, a thermocompressor TP-101, and a 4-effect (EV-101 to EV-104) evaporator. The four effects include a 10% (mass percentage) recycling of their output concentrate to their feed. The author (Ribeiro 2001) used his own algorithms for modelling most unit operation blocks, implemented as FORTRAN user models.

Live steam (water vapour, 6.67 bar) is fed to the system and sent to the thermocompressor to give it the required properties before being sent to the evaporator. The thermocompressor also processes recycled vapour, which reduces the overall steam consumption. The pre-heaters do not need to be fed with live steam, because they receive recycled vapour from the evaporator effects.

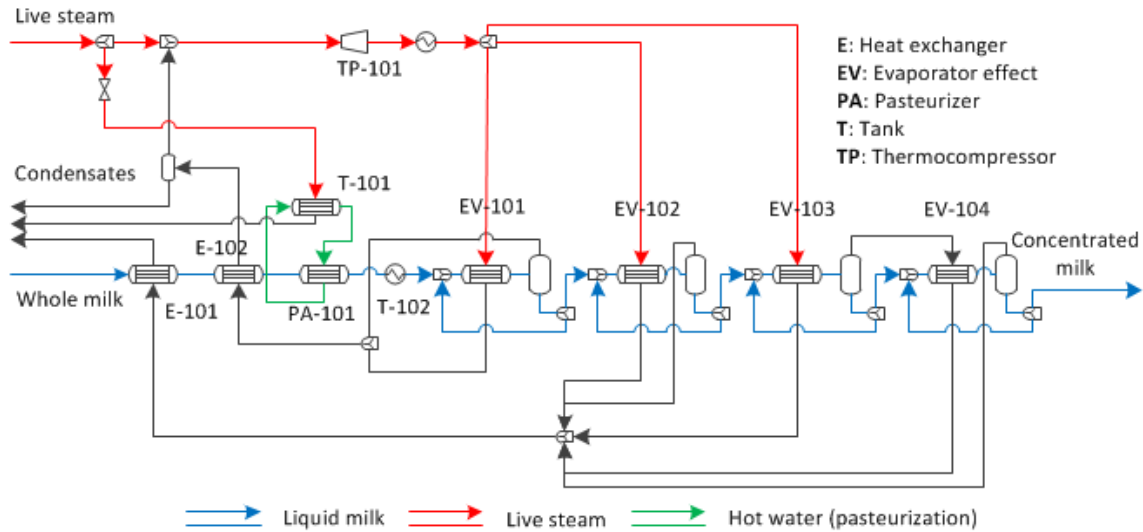

Figure 1: Flowsheet of the milk concentration process studied - 4-effect evaporator - one steam entry - [Microsoft Visio 2010], [Ribeiro 2001, Ribeiro and Andrade 2003]

2.3. Process modelling

The process studied (Ribeiro, 2001) involves 11352 kg/h of a 12% total solids-standardised milk as raw material, and produces 2742 kg/h of concentrated milk with a concentration of 50% total solids. In this reference case study, a specific code was developed to model the unit operations. The same unit operations, process conditions and boundaries are used in this work, and implemented in the ASPEN PLUS simulator. The purpose here is not to develop new algorithms for the different unit operations involved in the reference plant to model it more accurately, but consists in developing a model based on generic built-in unit operation blocks of the simulator, in order to allow a rather straightforward simulation set up as proposed in Table 1.

Table 1: ASPEN PLUS model blocks used for unit operations in the process model

Unit operation	ASPEN PLUS block
Pre-heaters E-101 & E-102	HeatX (heat exchanger) with Shortcut model
Pasteurizer PA-101	HeatX with Shortcut model
Stabilizing tank T-102	Heater (simple temperature decrease)
Thermocompressor TP-101	1 Compr with Turbine model + 1 Heater for temperature correction
Evaporator = effects EV-101 to EV-104	1 effect = 1 HeatX with Shortcut model + 1 Flash2 (Flash2 for the separation of concentrate and evaporated water)

The pre-heaters (E-101 and E-102) and the pasteurizer (PA-101), modelled as heat exchangers according to the Shortcut model, operate in “Design” mode for the simulation, which means that ASPEN PLUS calculates the equipment size by itself, with respect to specifications concerning cold side (milk side) outlet temperature. The evaporator effects, assimilated to heat exchangers and flash columns, operate in “Simulation” mode (the user is required to specify the exchanger area).

It must be yet highlighted that a few minor differences occur between the reference process and the process studied in this work, as illustrated in figure 1: (i) there is only one steam input (live steam) to the process; (ii) after expansion in the turbine, steam is fed to the first three effects.

2.4. Environmental data

Only the impacts due to steam and milk production at farm are considered for the environmental assessment. It must be emphasized that this preliminary work does not embed process equipment cleaning and electricity consumption of transfer units (pumps), and environmental impacts associated with equipment manufacturing. The functional unit of the analysis is the production of 1 ton of 50% - concentrated milk.

Environmental assessment requires either real values (from measurements, industrial data, etc.) or averaged values/estimations from databases (Jiménez-González and Constable, 2011, EcoInvent database, EcoInvent centre 2012) to calculate the Life Cycle Inventory (LCI) for steam production. Two scenarios are compared, i.e. cradle-to-gate, which considers the emissions associated from the extraction of the used energy sources to process impacts, and on-site steam production, which only involves the impacts associated with the process. Although the first scenario can be classified as a standard LCA situation, the on-site scenario evaluates only the production of steam, without accounting for the emissions from fuel extraction, transport, etc.

In order to evaluate on-site steam production, data from the EcoInvent database is used and compared with the software tool ARIANE (ARIANE 8.4, Prosim SA). It is a decision-making support tool dedicated to the management of utilities (steam, electricity ...) production units. ARIANE can perform the simulation and optimization of energy production processes, such as boilers, turbogenerators, heat engines, and others. Moreover, its database contains emissions data and impact factors to enable the characterization of fumes according to their pollutant content (CO₂, NO_x, etc.). The ARIANE simulator is used to model a gas turbine, previously described in Ouattara 2011 for steam production. All parameters are chosen for a scenario where only natural gas is used as a fuel.

In order to compare the different scenarios, emission rates of carbon dioxide CO₂, sulfur oxides SO_x and nitrous oxides NO_x, are selected (given per energy unit or per steam flow rate unit):

For the assessment of milk environmental burden used as a raw material for milk powder production, three different sources are used: milk at the farm gate, USA region (Thoma et al., 2012b); milk at the farm gate and transportation, USA and Europe regions (Gerber et al., 2010); milk transportation, USA region (Ulrich et al., 2012).

3. Simulation results and sensitivity study

3.1. Process model validation

The heat transfer area is calculated by ASPEN PLUS to reach the desired concentration at the output of the last effect (50% solids content). The computed surface is about 52% lower than the reference one, which might be explained by the fact that the evaporator mathematical model that was developed in Ribeiro (2001), and Ribeiro and Andrade (2002), accepted a very low temperature difference between the hot and the cold fluid input, which is not the case with the ASPEN PLUS shortcut model.

This difference in temperature levels is observed at every effect output: the temperatures obtained in this study are higher, so that adjustments have to be made, such as the feeding of the third effect with live steam instead of the recycled cow water from the second effect, and a lower heat transfer area value on the fourth effect. These changes made it possible to reach the same milk concentration values after evaporation in the four effects. Some typical results and design aspects are summarized in Table 2.

The results obtained with milk defined as a mixture of five conventional components, representing water and four categories of components, are close to the original model as far as heat duty and evaporation efficiency are concerned.

Table 2: Comparison of heat duty, heat transfer area and milk outlet concentration results between the study in Ribeiro, 2001 (Ref.) and this work

Evaporator effect	Heat duty (kW)			Heat transfer area (m ²)			Milk outlet concentration in mass % (temperature in °C)		
	Ref.	Proc.	ΔQ	Ref.	Proc.	ΔA	Ref.	Proc.	ΔC
EV-101	2952	3041	3%	106	106	< 1%	20,5 (66)	20,5 (71)	< 1%
EV-102	796	801	< 1%	73	72	< 1%	25,3 (61)	25,3 (67)	< 1%
EV-103	824	828	< 1%	88	88	< 1%	33,4 (56)	33,4 (64)	< 1%
EV-104	856	855	< 1%	94	45	-52%	49,7 (47)	49,7 (58)	< 1%

However a relatively high discrepancy is observed as far as temperature levels are concerned. This needs to be further investigated since milk is a heat-sensitive product whose nutritional and functional

properties must be controlled. Further developments are required to find appropriate values of heat capacities in particular.

3.2. Sensitivity study

The process model previously developed is considered as an acceptable base to perform a sensitivity study.

As the process is based on a 4-effect evaporator, and that the dairy industry evaporators generally comprise between three and five effects, the same process is designed again for these bound cases. The steam flow rate needs to be updated by simulation to achieve the level of concentration of 50%. The evaporator effects design and operating parameters (heat transfer area, pressure drop, heat exchange coefficient) are kept unchanged. For five effects, the additional effect receives cow water vapour from the fourth effect as hot fluid while its own cow water and water vapour are recycled to the first pre-heater. The new effect design is roughly calculated from the other effects parameters: heat transfer area is set up at about half the size of the fourth effect, and the pressure drop is determined to fit the trend line of the other effects. The first-heater is designed again once more by the simulator, and the same procedure with the Design-spec block is applied to reach a milk concentration as in the previous cases. The parameters of the three cases are summarized in Table 3.

Table 3: Evaporator effects design and operating parameters

Evaporator effect	Heat transfer area (m ²)	Outlet pressure (bar)	Number of effects		
			3	4	5
EV-101	106	26140	X	X	X
EV-102	72	20870	X	X	X
EV-103	88	16110	X	X	X
EV-104	45	9320		X	X
EV-105	20	4305			X

As expected, the higher the number of effects, the lower the calculated steam requirements, as compared to four effects: for three effects the steam requirements calculated by the simulator is 4095 kg/h (+13,75%), and for five effects the steam requirements calculated by the simulator is 3205 kg/h (-10,97%).

The performance of the simulator is then satisfactory, as the obtained results are consistent with what is commonly known in the dairy industry, and in each case the same required milk concentration is obtained. Such an analysis is interesting to evaluate the compromise between energy savings by increasing the number of effects and investment costs. The evaporator operating conditions are presented in Table 4.

Table 4: Evaporator operating conditions used in the simulation cases

Evap. effect	Feed flow rate (t/h)			Feed concentration (mass %)			Outlet concentration (mass %)			Steam flow rate in t/h (temperature in °C)		
	3	4	5	3	4	5	3	4	5	3	4	5
EV-101	12,0	12,1	12,2	12,6	12,5	12,4	23,7	20,5	18,5	5,6 (80)	4,7 (80)	3,9 (80)
EV-102	6,2	7,3	8,1	24,3	20,9	18,7	32,0	25,3	21,6	1,5 (80)	1,2 (80)	1,0 (80)
EV-103	4,6	5,4	6,9	33,2	25,3	22,0	49,7	33,4	26,3	1,5 (80)	1,3 (80)	1,1 (80)
EV-104		4,4	5,6		34,5	26,9		49,7	34,2		1,3 (64)	1,1 (52)
EV-105			4,3			35,3			49,7			1,2 (44)

4. Environmental assessment of the process

The energy consumption of the process considered in this work, i.e. steam consumption, depends on the choice of the primary energy sources and leads to the emission of pollutants to the air, the aquatic environment, and to the ground, as well as waste production.

The first scenario explored is assessed with data from the book Jiménez-González and Constable, 2011, in which the cradle-to-gate LCI parameters are given assuming 50% natural gas and 50% fuel oil consumption for the production of steam. Data from EcoInvent involved parameters assuming production only from natural gas.

The second scenario concerns on-site steam production, for which 100% natural gas is assumed as the primary energy source. This situation is modelled with the ARIANE model, allowing the choice of the fuel. However the EcoInvent database used here assumes an energy mix including natural gas and fuel oil, and the emission rates given are to be considered for this energy mix.

The emission rates obtained are calculated according to the number of effects in the milk concentration process and according to the considered scenario. Results are given in Table 5.

Table 5: Emission rates with respect to the number of evaporator effects and the scenario considered

LCI parameter	Scenario	Number of effects		
		3	4	5
CO ₂ emissions (kg/1000 kg of concentrated milk)	Cradle-to-gate from Jiménez-González and Constable, 2011	1554	1366	1216
	Cradle-to-gate from EcoInvent	1391	1223	1089
	On-site from ARIANE	313	274	243
	On-site from EcoInvent	379	334	297
NO _x emissions (kg/1000 kg of concentrated milk)	Cradle-to-gate from Jiménez-González and Constable, 2011	5,11	4,49	4,00
	Cradle-to-gate from EcoInvent	2,62	2,30	2,05
	On-site from ARIANE	4,83E-05	4,23E-05	3,74E-05
	On-site from EcoInvent	1,02	0,90	0,80
SO _x emissions (kg/1000 kg of concentrated milk)	Cradle-to-gate from Jiménez-González and Constable, 2011	6,80	5,98	5,32
	Cradle-to-gate from EcoInvent	0,56	0,50	0,44
	On-site from ARIANE	0,23	0,20	0,18
	On-site from EcoInvent	2,40	2,11	1,88

It can be observed that the emission rate values obtained with the different sources exhibit the same order of magnitude for a given scenario. The differences between Jiménez-González and Constable (2011) and EcoInvent for the cradle-to-gate scenario may be attributed to different environmental data assumptions (fuel mix 50% natural gas – 50% fuel oil for Jiménez-González and Constable, 2011), sources and calculation methods. ARIANE calculates impacts from fuel combustion only, which may explain the lowest values obtained as compared to the EcoInvent emission values. Since they are consistent with the EcoInvent ones, and because the turbine model allows flexibility in the choice of the fuel, the ARIANE model will be selected in our further studies.

Not surprisingly, the on-site scenario shows lower values as compared to those related to the cradle-to-gate scenario. This is due to the impacts of fuel extraction, transportation, electricity consumption, and other production chain-related emissions that have not been taken into account.

In order to fully achieve the environmental assessment, the impacts related to milk considered as raw material must be accounted for. Most studies reported in the literature give greenhouse gas (GHG) emissions for milk at the farm gate and for milk “farm to processor” transportation in kg CO_{2EQ}/kg FPCM (kg CO₂ equivalent per kg fat and protein-corrected milk), which cannot be compared to direct CO₂ emissions, since CO_{2EQ} entails methane and other gases. Milk production GHG emissions at the farm gate are added to emissions from transportation, giving the total emissions of milk before processing, presented in the Table 6.

The average value is 0,72 kg CO_{2EQ}/kg FPCM, which is about 300% higher than the value calculated for the European region. Although such a difference is not inconsistent at such a low order of magnitude and is typical between LCA studies (different regions, timeframes, calculation methods, etc.), this may suggest that more accurate data must be used to estimate the environmental burden of milk at the farm gate, particularly according to the region concerned.

Table 6: GHG emission factors for whole milk before processing in plant

Source (see part 2.4)	Region	GHG emissions (kgCO _{2EQ} /kg FPCM)
Gerber et al. (2010)	Europe	0,17
Thoma et al. (2012b) + Ulrich et al. (2012)	USA	1,28
Thoma et al. (2012b) + Gerber et al. (2010)	USA	1,45
Gerber et al. (2010)	USA	0,44
Gerber et al. (2010) + Ulrich et al. (2012)	USA	0,27

5. Conclusion

This paper presented a model for milk concentration process with the ASPEN PLUS (AspenTech, Inc.) chemical process simulator coupled with an environmental model based on Life Cycle Assessment concepts. Milk definition as a mixture of its five major constituents in the simulator gives satisfying results regarding the evaporation, with a few design modifications of the reference process due to the use of built-in unit operation models. A sensitivity study is performed, where the number of effects in the evaporator is changed, using the computing capabilities of the simulator to evaluate the new steam requirements. The environmental assessment is realised, consisting in the calculation of emission rates of CO₂, NO_x and SO_x, based on the results of the simulation and LCI parameters extracted from the EcoInvent database. Two scenarios are compared, i.e. cradle-to-gate and on-site steam production, for which several sources are used, and GHG emissions of milk as a raw material are evaluated according to the latest studies reported.

Further developments of this methodology will consist in:

- A more rigorous definition of milk as a mixture of its five main components, so that it can be applied in any generic chemical process simulator;
- The addition of a model for the drying step to simulate milk powder production;
- The calculation of electricity requirements and cleaning utilities streams, which drastically changes the environmental assessment since chemical solutions are involved;
- The calculation of all environmental impacts according to LCA impact categories (Global Warming Potential, Acidification Potential, etc.) for direct use of the environmental assessment results;
- The application of multiobjective optimization techniques to help decision-making in the design of milk concentration processes.

The final step will be the development of a framework with which it will be possible to systemize the simulation and environmental assessment of milk concentration processes, so as to perform their optimization.

References

- ARIANE version 8.4.0.1. Utilities management and power plant optimization software. ProSim, SA, 2011.
- ASPEN PLUS version 7.3. Chemical modelling software. Aspen Technology, Inc., 2011.
- Azapagic, A., Perdan, S., Clift, R. *Sustainable development in practice: Case Studies for Engineers and Scientists*. John Wiley & Sons, 2011.
- Banga, J. R., Balsa-Canto, E., Moles, C. G., Alonso, A. A. Improving food processing using modern optimization methods. *Trends in Food Science and Technology*, 2003, 14, 131 – 144.

- Bon, J., Clemente, G., Vaquiro, H., Mulet, A. Simulation and optimization of milk pasteurization processes using a general process simulator (ProSimPlus). *Computers and Chemical Engineering*, 2010, 34, 414 – 420.
- Cheng, H. & Friis, A. Operability and Flexibility of a Milk Production Line. *Food and Bioproducts Processing*, 2007, 85, 372 – 380.
- Choi, Y. & Okos, M.R. 1986. “Effects of Temperature and Composition on the Thermal Properties of Foods”. *Journal of Food Process and Applications*. 1(1): 93 – 101.
- Diefes, H., Okos, M., Morgan, M. Computer-aided process design using Food Operations Oriented Design System Block Library. *Journal of Food Engineering*, 2000, 46, 99 – 108.
- EcoInvent Centre (2012), EcoInvent data v2.2. EcoInvent reports No.1-25, Swiss Centre for Life Cycle Inventories, Dübendorf, 2012.
- French Ministry of agriculture, food and forestry. *Agreste – Les consommations d'énergie dans les industries agricoles alimentaires et les scieries en 2010*. September 2011. <http://agreste.agriculture.gouv.fr/publications/chiffres-et-donnees/article/les-consommations-d-energie-dans-6820>. (In French).
- Gerber, P., Vellinga, T., Opio, C., Henderson, B., & Steinfeld, H. Greenhouse gas emissions from the dairy sector: A life cycle assessment. Rome, Italy: Food and Agriculture Organization of the United Nations Animal Production and Health Division, 2010.
- Jeantet, R., Brulé, G., Delaplace, G. *Génie des procédés appliqué à l'industrie laitière*. Lavoisier Tec et Doc, 2011, 137-153. (In French).
- Jeantet, R., Croguennec, T., Schuck, P., Brulé, G. *Science des aliments. Biochimie-Microbiologie-Procédés-Produits*. Lavoisier Tec et Doc, 2007, 33-40. (In French).
- Jiménez-González, C. & Constable, D. J. C. Impacts of energy requirements. In: *Green Chemistry and Engineering: A Practical Design Approach*. John Wiley & Sons, 2011, 519-539.
- Minim, L. A., Coimbra, J. S. R.; Minim, V. P. R. & Telis-Romero, J. Influence of Temperature and Water and Fat Contents on the Thermophysical Properties of Milk. *Journal of Chemical & Engineering Data*, 2002, 47, 1488-1491.
- Ouattara, A. *Méthodologie d'éco-conception de procédés par optimisation multiobjectif et aide à la décision multicritère*. Mécanique, Energétique, Génie Civil et Procédés (MEGeP), 2011 (In French)
- Ouattara, A., Pibouleau, L., Azzaro-Pantel, C., Domenech, S., Baudet, P., Yao, B. Economic and environmental strategies for process design. *Computers and Chemical Engineering*, 2012, 36, 174 – 188.
- Ribeiro, C. P. & Andrade, M. H. C. A heat transfer model for the steady-state simulation of climbing-falling-film plate evaporators. *Journal of Food Engineering*, 2002, 54, 309 - 320
- Ribeiro, C. P. & Andrade, M. H. C. Performance Analysis of the Milk Concentrating System from a Brazilian Milk Powder Plant. *Journal of Food Process Engineering*, 2003, 26, 181-205.
- Ribeiro C.P., 2001. *Modelling of plate heat-transfer systems and simulation of a Brazilian milk powder plant*. M. Sc. Thesis. Belo Horizonte, UFMG. (In Portuguese).
- SIMAPRO version 7.3.3. LCA software. PRé Consultants, 2011.
- Steffens, M., Fraga, E., Bogle, I. Multicriteria process synthesis for generating sustainable and economic bioprocesses. *Computers and Chemical Engineering*, 1999, 23, 1455 – 1467.
- Thoma, G.; Popp, J.; Nutter, D.; Shonnard, D.; Ulrich, R.; Matlock, M.; Kim, D. S.; Neiderman, Z.; Kemper, N.; East, C. & Adom, F. Greenhouse gas emissions from milk production and consumption in the United States: A cradle-to-grave life cycle assessment circa 2008. *International Dairy Journal*, 2012, in press.
- Trystram G., Modelling of food and food processes. *Journal of Food Engineering*, 2012, 110, 269 – 277.
- Ulrich, R., Thoma, G. J., Nutter, D. W., & Wilson, J. (2012). Tailpipe greenhouse gas emissions from tank trucks transporting raw milk from farms to processing plants. *International Dairy Journal*.
- Wooley, R. J. & Putsche, V. Development of an ASPEN PLUS physical property database for biofuels components. NREL National Renewable Energy Laboratory Golden, CO, 1996.

Simulation de procédés et analyse environnementale dans l'industrie laitière – application à la concentration du lait

Résumé

La concentration et le séchage du lait sont des opérations très consommatrices d'énergie, pour lesquelles la consommation d'énergie compte pour près de 25% dans l'industrie laitière française. Un défi majeur consiste alors à concevoir et développer des procédés laitiers de concentration qui intègrent des critères techniques, économiques et environnementaux. Dans ce but, des outils orientés systèmes ont déjà été développés dans les industries chimiques en utilisant une approche systémique qui combine modélisation, simulation, et optimisation. Malgré la proximité du secteur de la chimie avec les secteurs agroalimentaire et de la bio-ingénierie, l'utilisation d'une telle approche pour la modélisation des procédés laitiers souffre d'un manque de modèles de procédés, plus particulièrement lorsque le procédé est considéré dans son ensemble (de la matière première au produit final) et d'autant plus lorsqu'il s'agit de procédé de concentration. Dans ce contexte, ce travail constitue une étude préliminaire en vue du développement d'un cadre méthodologique pour modéliser et optimiser les procédés laitiers. La stratégie proposée consiste à combiner un simulateur de procédés chimiques (ASPEN PLUS 7.3, AspenTech, Inc.) avec un modèle environnemental basé sur les concepts de l'Analyse du Cycle de Vie. Le procédé simulé concerne la production de poudre de lait, et plus particulièrement la concentration du lait avant séchage, ce qui implique des étapes de préchauffage, pasteurisation, et évaporation. Les performances du modèle du procédé sont évaluées à travers une étude de sensibilité sur le nombre d'effets dans l'évaporateur, et les impacts environnementaux associés aux divers besoins en vapeur considérés sont quantifiés en fonction de plusieurs scénarii.

Mots-clés: industrie laitière ; simulation ; analyse environnementale ; procédé de concentration.