



**HAL**  
open science

## The Complexity of Finding Effectors

Laurent Bulteau, Stefan Fafianie, Vincent Froese, Rolf Niedermeier, Nimrod Talmon

► **To cite this version:**

Laurent Bulteau, Stefan Fafianie, Vincent Froese, Rolf Niedermeier, Nimrod Talmon. The Complexity of Finding Effectors. *Theory of Computing Systems*, 2017, 60 (2), pp.253-279. 10.1007/s00224-016-9670-8 . hal-01494357

**HAL Id: hal-01494357**

**<https://hal.science/hal-01494357>**

Submitted on 23 Mar 2017

**HAL** is a multi-disciplinary open access archive for the deposit and dissemination of scientific research documents, whether they are published or not. The documents may come from teaching and research institutions in France or abroad, or from public or private research centers.

L'archive ouverte pluridisciplinaire **HAL**, est destinée au dépôt et à la diffusion de documents scientifiques de niveau recherche, publiés ou non, émanant des établissements d'enseignement et de recherche français ou étrangers, des laboratoires publics ou privés.

## The Complexity of Finding Effectors

Laurent Bulteau · Stefan Fafianie ·  
Vincent Froese · Rolf Niedermeier ·  
Nimrod Talmon

Received: date / Accepted: date

**Abstract** The NP-hard EFFECTORS problem on directed graphs is motivated by applications in network mining, particularly concerning the analysis of probabilistic information-propagation processes in social networks. In the corresponding model the arcs carry probabilities and there is a probabilistic diffusion process activating nodes by neighboring activated nodes with probabilities as specified by the arcs. The point is to explain a given network activation state as well as possible by using a minimum number of “effector nodes”; these are selected before the activation process starts.

We correct, complement, and extend previous work from the data mining community by a more thorough computational complexity analysis of EFFECTORS, identifying both tractable and intractable cases. To this end, we also

---

An extended abstract appeared in *Proceedings of the 12th Annual Conference on Theory and Applications of Models of Computation (TAMC '15)*, Volume 9076 of LNCS, pages 224–235, Springer, 2015. This article provides all proofs in full detail.

Laurent Bulteau was supported by the Alexander von Humboldt Foundation, Bonn, Germany. Main work done while affiliated with TU Berlin.

Stefan Fafianie was supported by the DFG Emmy Noether-program (KR 4286/1). Main work done while affiliated with TU Berlin.

Vincent Froese was supported by the DFG, project DAMM (NI 369/13).

Nimrod Talmon was supported by DFG Research Training Group “Methods for Discrete Structures” (GRK 1408).

---

Laurent Bulteau  
IGM-LabInfo, CNRS UMR 8049, Université Paris-Est Marne-la-Vallée, France.  
E-mail: Laurent.Bulteau@u-pem.fr

Stefan Fafianie  
Institut für Informatik, Universität Bonn, Germany.  
E-mail: stefan.fafianie@tu-berlin.de

Vincent Froese, Rolf Niedermeier, and Nimrod Talmon  
Institut für Softwaretechnik und Theoretische Informatik, TU Berlin, Germany.  
E-mail: {vincent.froese,rolf.niedermeier}@tu-berlin.de, nimrodtalmon77@gmail.com

exploit a parameterization measuring the “degree of randomness” (the number of ‘really’ probabilistic arcs) which might prove useful for analyzing other probabilistic network diffusion problems as well.

**Keywords** Probabilistic Information Propagation · Influence Maximization · Network Activation · Social Networks · Exact Algorithms · Parameterized Complexity

## 1 Introduction

To understand and master the dynamics of information propagation in networks (biological, chemical, computer, information, social) is a core research topic in data mining and related fields. A prominent problem in this context is the NP-hard problem EFFECTORS [15]: The input is a directed (influence) graph with a subset of nodes marked as active (the target nodes) and each arc of the graph carries an influence probability greater than 0 and at most 1. Assuming a certain diffusion process on the graph, the task is to find few “effector nodes” that can “best explain” the set of given active nodes, that is, the activation state of the graph.

Specifically, consider a set of nodes in the graph which are initially active. Then, due to a certain diffusion process, several other nodes in the graph, which initially were not active, might become active as a result. The diffusion model we consider (and which is known as the independent cascade model [14]) is such that, at each time step, a newly activated node (initially only the chosen effectors are active) has one chance to activate each non-active out-neighbor with the corresponding arc probability. If an out-neighbor was successfully activated in the last time step, then the propagation continues and this node has the chance to further activate its out-neighbors. The propagation process terminates when there are no newly activated nodes. Figure 1 shows an example of a possible propagation process. Given the activation state of the graph at the end of the propagation process, we ask for the set of nodes, the effectors, which could best explain the current activation state.

Being able to efficiently compute the set of effector nodes is helpful in many scenarios. The paper by Lappas et al. [15] mentions several of them, including being able to better understand how information propagates in social networks, or finding those countries which are more prominent for spreading epidemics (here, one might assume a graph where each country is a node, and, given the current state of some plague, the effector nodes are those countries which explain this current state). Motivated also by the scenario from epidemics, one might be interested in providing shields against such plagues. One possible way to achieve this is by finding the set of effectors, and vaccinating the people in those countries. Taking monetary costs into account, it is desirable to find a small set of effectors; thus, in the EFFECTORS problem, the goal is to find a set of effectors of small size.

It is important to note that we allow effectors to be chosen from the *whole* set of graph nodes and not only from the set of target nodes. This makes our

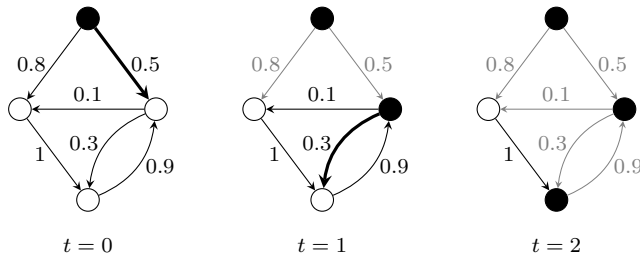

**Fig. 1** An example depicting the information propagation according to the independent cascade model. The influence graph is a directed graph where the arcs are labeled with influence probabilities. Initially, at time  $t = 0$ , only the top node is active (black) and has a chance to independently activate the left and right node with the corresponding arc probabilities. In the example, the right node is activated (thick arc) while the left node is not. The probability of this event is thus  $0.5 \cdot (1 - 0.8)$ . The propagation then continues and the right node has a chance to activate its out-neighbors at time  $t = 1$ . Every activated node has only one chance (namely, after it became active the first time) to activate other inactive nodes. Note that at time  $t = 2$  the bottom node cannot activate any new nodes. Hence, the propagation process terminates. The overall probability of this particular propagation (and of this particular activation state) equals  $0.5 \cdot (1 - 0.8) \cdot 0.3 \cdot (1 - 0.1) = 0.027$ .

model, in a sense, more general than the original one by Lappas et al. [15].<sup>1</sup> See Section 2 for definitions of the main problems, formal definition of our model, and a discussion about our model and its difference to that of Lappas et al. [15].

Our main contribution is to extend and clarify research on the computational complexity status of EFFECTORS, which has been initiated by Lappas et al. [15]. In short, Lappas et al. [15] have shown that EFFECTORS is generally NP-hard and hard to approximate, developed an algorithm that is efficient on trees, and used it to develop an efficient heuristic. As *probabilistic* information propagation is central in the independent cascade information-propagation model which is in the heart of the EFFECTORS problem (as well as in several other information-propagation models), we put particular emphasis on studying how the “degree of randomness” in the network governs the computational complexity. Moreover, compared to previous work, we make an effort to present the results in a more formal setting, conducting a rigorous mathematical analysis.

Informally speaking (concrete statements of our results appear in Section 2 after having provided formal definitions), we have gained the following main insights (also refer to Table 1 in Section 2).

- With unlimited degree of randomness, finding effectors is computationally very hard. In fact, even computing the “cost” (how well does a set of effectors explain a given activation state) of a *given* set of effectors is intractable. This significantly differs from deterministic models.

<sup>1</sup> We conjecture that both models coincide if we are allowed to choose an unlimited number of effectors, that is, if the number of chosen effectors does not matter. On the contrary, they do not coincide if the number of effectors is bounded, see Section 2.

- Even if the directed input graph is acyclic, then this does *not* lead to a significant decrease of the computational complexity.
- Bounding the degree of randomness (in other words, bounding the number of arcs with probability different from 1), that is, *parameterizing on the degree of randomness*, yields some encouraging (fixed-parameter) tractability results for otherwise intractable cases.
- We identify some flaws in the work of Lappas et al. [15] (see Section 5.4 for details), who claim one case to be intractable which in fact is tractable and one case the other way around.

Admittedly, in real-world applications (where influence probabilities are determined through observation and simulation, often involving noise) the number of probabilistic arcs may be high, thus, at first sight, rendering the parameter “number of probabilistic arcs” doubtful. However, note that finding effectors is computationally very hard (also in terms of polynomial-time approximability; the approximation hardness of EFFECTORS is mentioned by Lappas et al. [15] and follows, for example, from the reductions which use the SET COVER problem). So, in order to make the computation of a solution more feasible one might round up (to 1) arc probabilities which are close to 1 and round down (to 0) arc probabilities which are close to 0. Thus, one can achieve a trade-off between running time and accuracy of the result. Depending on the degree of rounding (as much as a subsequent fixed-parameter algorithm exploiting the mentioned parameter would “allow”), in this way one might at least find a good approximation of an optimal set of effectors in reasonable time.

*Related work.* Our main point of reference is the work of Lappas et al. [15]. Indeed, we use a slightly different problem definition: They define the effectors to be necessarily a subset of the target nodes, whereas we allow the effectors to form an arbitrary subset of the nodes. It turns out that these two definitions really yield different problems, in the sense that a solution for one problem might not be a solution for the other (see Section 3 for an extensive discussion of the differences between these two models and for an explanation on why we have chosen to define our model as it is defined).

The special case where all nodes are target nodes (and hence where the two models above clearly coincide) is called INFLUENCE MAXIMIZATION and is well studied in the literature [7, 10, 14]. Specifically, it is known that the INFLUENCE MAXIMIZATION problem is NP-hard, and a polynomial-time  $(1 - 1/e)$ -approximation algorithm for this problem is given by Kempe et al. [14].

Finally, a closely related deterministic version (called TARGET SET SELECTION) with the additional difference of having node-individual thresholds specifying how many neighboring nodes need to be active to make a node active has also been extensively studied, in particular from a parameterized complexity point of view [4, 5, 6, 8, 16]. TARGET SET SELECTION is NP-hard in general, and hard to approximate, also in the parameterized sense (specifically, cannot be approximated even in FPT-time (see Section 2) with respect

to the solution size). It is NP-hard even on graphs of diameter 2 [16], and it is tractable on some restricted graph classes such as trees [6] and cliques [16].

## 2 Preliminaries

In this section, we provide definitions used throughout the work. We basically use the same definitions as Lappas et al. [15], except for few differences in notation.

*Graph Theory.* We consider simple directed graphs  $G = (V, E)$  with a set  $V$  of nodes and an arc set  $E \subseteq \{u \rightarrow v \mid u, v \in V, u \neq v\}$ . If there is an arc  $u \rightarrow v \in E$ , then we call  $u$  an *in-neighbor* of  $v$  and we call  $v$  an *out-neighbor* of  $u$ . For a subset  $V' \subseteq V$ , we denote by  $G[V'] := (V', E')$  the subgraph of  $G$  induced by  $V'$ , where  $E' := \{u \rightarrow v \in E \mid u, v \in V'\}$ . An undirected graph  $G = (V, E)$  consists of a vertex set  $V$  and an edge set  $E \subseteq \{\{u, v\} \mid u, v \in V, u \neq v\}$ .

We use the acronym DAG for directed acyclic graphs. An undirected *tree* is a connected acyclic graph. A *directed tree* is an arbitrary orientation of an undirected tree. The *condensation* of a directed graph  $G$  is a DAG containing a node  $v_C$  for each strongly connected component  $C$  of  $G$  and there is an arc  $v_C \rightarrow v_{C'}$  if and only if there exists at least one arc from a node in  $C$  to a node in  $C'$ .

*Influence Graphs.* An *influence graph*  $G = (V, E, w)$  is a simple directed graph equipped with a function  $w : E \rightarrow (0, 1] \cap \mathbb{Q}$  assigning an *influence weight* to each arc  $u \rightarrow v \in E$  which represents the *influence of node  $u$  on node  $v$* . Strictly speaking, the influence is the probability that  $u$  propagates some information to  $v$ . We denote the number of nodes in  $G$  by  $n := |V|$  and the number of arcs in  $G$  by  $m := |E|$ .

*Information Propagation.* We consider the following information-propagation process, called the *Independent Cascade (IC)* model [14]. Within this model, each node is in one of two states: *active* or *inactive*. When a node  $u$  becomes active for the first time, at time step  $t$ , it gets a single chance to activate its inactive out-neighbors. Specifically,  $u$  succeeds in activating a neighbor  $v$  with probability  $w(u \rightarrow v)$ . If  $u$  succeeds, then  $v$  will become active at step  $t + 1$ . Otherwise,  $u$  cannot make any more attempts to activate  $v$  in any subsequent round. The propagation process terminates when there are no newly activated nodes, that is, when the graph becomes static.

We remark that, since our algorithms need to manipulate the probabilities determined by the function  $w$ , technically (and as usually) we assume that the precision of the probabilities determined by this function is polynomially upper-bounded in the number  $n$  of nodes of the input graph, and we ignore the time costs for adding or multiplying rational numbers assuming that these operations take constant time.

*Cost Function.* For a given influence graph  $G = (V, E, w)$ , a subset  $X \subseteq V$  of effectors, and a subset  $A \subseteq V$  of active nodes, we define a cost function

$$C_A(G, X) := \sum_{v \in A} (1 - p(v|X)) + \sum_{v \in V \setminus A} p(v|X),$$

where for each  $v \in V$ , we define  $p(v|X)$  to be the probability of  $v$  being active after the termination of the information-propagation process starting with  $X$  as the active nodes. An alternative definition is that  $C_A(G, X) := \sum_{v \in V} C_A(v, X)$ , where  $C_A(v, X) := 1 - p(v|X)$  if  $v \in A$  and  $C_A(v, X) := p(v|X)$  if  $v \notin A$ . One might think of this cost function as computing the expected number of nodes which are incorrectly being activated or unactivated.

*Main Problem Definition.* Our central problem EFFECTORS is formulated as a decision problem—it relates to finding few nodes which best explain (lowest cost) the given network activation state specified by a subset  $A \subseteq V$  of nodes.

EFFECTORS

**Input:** An influence graph  $G = (V, E, w)$ , a set of target nodes  $A \subseteq V$ , a budget  $b \in \mathbb{N}$ , and a cost  $c \in \mathbb{Q}$ .

**Question:** Is there a subset  $X \subseteq V$  of effectors with  $|X| \leq b$  and cost  $C_A(G, X) \leq c$ ?

We will additionally consider the related problem EFFECTORS-COST (see Section 4) where the set  $X$  of effectors is already given and one has to determine its cost.

*Parameters.* The most natural parameters to consider for a parameterized computational complexity analysis are the maximum number  $b$  of effectors, the cost value  $c$ , and the number  $a := |A|$  of target nodes. Moreover, we will be especially interested in quantifying the amount of randomness in the influence graph. To this end, consider an arc  $u \rightarrow v \in E$ : if  $w(u \rightarrow v) = 1$ , then this arc is not probabilistic. We define the parameter number  $r$  of probabilistic arcs, that is,  $r := |\{u \rightarrow v \in E : w(u \rightarrow v) < 1\}|$ .

*Parameterized Complexity.* We assume familiarity with the basic notions of algorithms and complexity. Several of our results will be cast using the framework of parameterized complexity analysis. An instance  $(I, k)$  of a parameterized problem consists of the classical instance  $I$  and an integer  $k$  being the *parameter* [11, 13, 17, 9]. A parameterized problem is called *fixed-parameter tractable* (FPT) if there is an algorithm solving it in  $f(k) \cdot |I|^{O(1)}$  time, whereas an algorithm with running time  $|I|^{f(k)}$  only shows membership in the class XP (clearly,  $\text{FPT} \subseteq \text{XP}$ ). One can show that a parameterized problem  $L$  is (under certain complexity-theoretic assumptions) not fixed-parameter tractable by devising a *parameterized reduction* from a W[1]-hard or W[2]-hard problem (such as CLIQUE or SET COVER, respectively, each parameterized by the

solution size) to  $L$ . A parameterized reduction from a parameterized problem  $L$  to another parameterized problem  $L'$  is a function that, given an instance  $(I, k)$ , computes in  $f(k) \cdot |I|^{O(1)}$  time an instance  $(I', k')$  with  $k' \leq g(k)$  such that  $(I, k) \in L \Leftrightarrow (I', k') \in L'$ . The common working hypothesis is that  $\text{FPT} \neq \text{W}[1]$ . In fact, it is assumed that there is an infinite hierarchy

$$\text{FPT} \subset \text{W}[1] \subset \text{W}[2] \subset \dots$$

called the  $W$ -hierarchy. Thus, for a parameterized problem to be  $\text{W}[2]$ -hard is even stronger in the sense that even if  $\text{FPT} = \text{W}[1]$  holds, it is still possible that  $\text{FPT} \neq \text{W}[2]$ .

*Counting Complexity.* We will also consider so called counting problems of the form “Given  $x$ , compute  $f(x)$ .”, where  $f$  is some function  $\{0, 1\}^* \rightarrow \mathbb{N}$  (see Arora and Barak [2, Chapter 9] for an introduction to counting complexity). The class  $\#\text{P}$  consists of all such functions  $f$  such that  $f(x)$  equals the number of accepting computation paths of a nondeterministic polynomial-time Turing machine on input  $x$ . Informally speaking, we can associate a decision problem in  $\text{NP}$  (which asks whether there exists a solution or not) with a counting problem in  $\#\text{P}$  (which asks for the number of solutions). Clearly, if all counting problems in  $\#\text{P}$  can be solved in polynomial time, then this implies  $\text{P} = \text{NP}$ . Analogously to  $\text{NP}$ -hardness, showing that a function is  $\#\text{P}$ -hard gives strong evidence for its computational intractability. A function  $f : \{0, 1\}^* \rightarrow \{0, 1\}^*$  is  $\#\text{P}$ -hard if a polynomial-time algorithm for  $f$  implies that all counting problems in  $\#\text{P}$  are polynomial-time solvable.

*Organization.* Before we discuss our model and the one by Lappas et al. [15], we overview our main results in Table 1. We will treat the sub-problem  $\text{EFFEFFECTORS-COST}$  in Section 4, and  $\text{EFFEFFECTORS}$  in Section 5. Note that most of our results transfer to the model of Lappas et al. [15]. In particular, this implies that their claims that the “zero-cost” special case is  $\text{NP}$ -hard [15, Lemma 1] and that the deterministic version is polynomial-time solvable are both flawed, because from our results exactly the opposite follows (see the last part of Section 5.4 for details).

### 3 Model Discussion

Our definition of  $\text{EFFEFFECTORS}$  differs from the problem definition of Lappas et al. [15] in that we do not require the effectors to be chosen among the target nodes. Before pointing out possible advantages and motivating our problem definition, we give a simple example illustrating the difference between these two definitions.

Consider the influence graph in Figure 2, consisting of one non-target node (white) having three outgoing arcs with probability 1 each to three target nodes (black). Clearly, for  $b = c = 1$ , this is a “no”-instance if we are only allowed to pick target nodes as effectors since the probability of being active



**Table 1** Computational complexity of the different variants of EFFECTORS. Note that all hardness results hold also for DAGs. The parameter  $a$  stands for the number of active nodes,  $b$  for the budget,  $c$  for the cost value, and  $r$  for the number of probabilistic arcs.

	Deterministic ( $r = 0$ )	Parameterized (by $r$ )	Probabilistic (arbitrary $r$ )
EFFECTORS-COST	FPT [wrt. $r$ ], Theorem 2		#P-hard, Corollary 1
EFFECTORS (general case)	XP [wrt. $\min(a, b, c)$ ], Proposition 1	W[2]-hard [wrt. $b + c$ ], Theorem 3 W[1]-hard [wrt. $a + b + c$ ], Theorem 3	
Infinite budget ( $b = \infty$ )	FPT [wrt. $r$ ], Theorem 5		NP-hard, Theorem 4 open: FPT[wrt. $a$ or $c$ ]
Influence Maximization ( $A = V$ )	FPT [wrt. $b + c$ ], Theorem 6	W[1]-hard [wrt. $\min(b, c)$ ], Theorem 6	

will be 0 for two of the three target nodes in any case, which yields a cost of at least 2. According to our problem definition, however, we are allowed to select the non-target node, which only incurs a cost of 1, showing that this is a “yes”-instance.

Let us compare the two models. First, we think that our model captures the natural assumption that an effector node does not have to remain active forever<sup>2</sup>. Indeed, the modeling of Lappas et al. [15] might be interpreted as a “monotone version” as for example discussed by Askalidis et al. [3], while in this sense our model allows for “non-monotone explanations”. Second, our model is more resilient to noise; consider, for example, Figure 2. It might be the case that indeed the top node is activated, however, due to noisy sampling methods, it looks to us as if this top node is inactive. In this simple example, a solution according to the model of Lappas et al. [15] would have to use three effectors to wrongly explain the data, while a solution according to our model would be compute a correct and optimal solution with only one effector.

Clearly, if all nodes are target nodes (this particular setting is called INFLUENCE MAXIMIZATION), then the two models coincide. Furthermore, we strongly conjecture that if we have an unlimited budget, then it suffices to search for a solution among the target nodes, that is, for  $b = \infty$ , we believe that the two problem definitions are also equivalent:

<sup>2</sup> Notably, in our model it actually remains active. The point is that before the whole computation starts (and after it ends) nodes may (have) become inactive again. Still, “temporary activeness” may make a node an effector that helps explaining the currently observed network activation state.

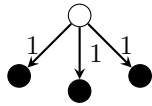

**Fig. 2** Example where it is optimal to choose a non-target node as effector.

*Conjecture 1* For  $b = \infty$ , it holds that every “yes”-instance  $(G, A, b, c)$  of EFFECTORS has a solution  $X \subseteq A$ .

At least for directed trees (that is, the underlying undirected graph is a tree—these also have been studied by Lappas et al. [15]) we can prove Conjecture 1. The idea of proof is that if an optimal solution contains a non-target node  $v$ , then this node only influences nodes reachable from it via paths that do not visit other nodes in the solution. Within this smaller tree of influenced nodes there must be some subtrees rooted at target nodes such that the expected cost for such a subtree is smaller if its target root node is activated during the propagation process compared to the case when it is not. Choosing these target nodes directly as effectors, replacing the non-target node  $v$ , yields another optimal solution with fewer non-target nodes.

**Theorem 1** *Conjecture 1 holds for directed trees.*

*Proof* Before proving the actual theorem, let us have a brief look on the probabilistics of the information-propagation process in directed trees. Clearly, in any influence graph, a node  $v$  can activate another node  $u$  only if there is a directed path from  $v$  to  $u$ . Note that in a directed tree this path is unique if it exists. Moreover, the probability  $p(u|X)$  only depends on those nodes  $v \in X$  that are connected to  $u$  by a directed path that contains no other node from  $X$ . To see that this is true, consider a node  $v \in X$  such that all directed paths from  $v$  to  $u$  contain another node from  $X$ . Then, on each of these paths the corresponding node  $x \in X$  has only one chance to activate  $u$  via propagation along the path. Since  $v$  cannot “re-activate”  $x$  ( $x$  is already active from the beginning), the activation probability of  $u$  does not depend on  $v$ . For a node  $v \in V$ , let  $\text{cl}(v) \subseteq V$  denote the *closure* of  $v$ , that is, the set of all nodes  $u \in V$  for which there exists a directed path from  $v$  to  $u$  (including  $v$  itself, that is,  $v \in \text{cl}(v)$ ).

Let  $(G = (V, E, w), A, b, c)$  with  $b = \infty$  be an input instance of EFFECTORS, where  $G$  is an arbitrary directed tree. Let  $X \subseteq V$  be an optimal solution with  $X \not\subseteq A$ , that is, there exists a node  $x \in X \setminus A$ . We show that there is an optimal solution  $X^*$  containing fewer non-target nodes than  $X$ . More formally, we show that there exists a solution  $X^*$  with  $x \notin X^*$  and  $X^* \setminus A \subsetneq X \setminus A$  such that  $C_A(G, X^*) \leq C_A(G, X)$ . Recursively applying this argument then proves the theorem.

First, note that if  $C_A(G, X') \leq C_A(G, X)$  holds for  $X' := X \setminus \{x\}$ , then we are done. Thus, we can assume  $C_A(G, X') > C_A(G, X)$ , or, equivalently:

$$\begin{aligned} & C_A(G, X') - C_A(G, X) > 0 \\ \Leftrightarrow & \sum_{v \in A} (1 - p(v|X')) + \sum_{v \in V \setminus A} p(v|X') - \left( \sum_{v \in A} (1 - p(v|X)) + \sum_{v \in V \setminus A} p(v|X) \right) > 0 \\ \Leftrightarrow & \sum_{v \in A} (p(v|X) - p(v|X')) - \sum_{v \in V \setminus A} (p(v|X) - p(v|X')) > 0. \end{aligned} \quad (1)$$

Now, consider a node  $v$  that is not in the closure of  $x$ . Clearly, it holds that  $p(v|X) = p(v|X')$  since there is no directed path from  $x$  to  $v$ , and thus  $x$  cannot change the probability of  $v$  becoming active during the information-propagation process. Therefore, if we let  $A_x := \text{cl}(x) \cap A$  and  $\bar{A}_x := \text{cl}(x) \setminus A_x$ , then Inequality (1) can be rewritten as

$$\sum_{v \in A_x} (p(v|X) - p(v|X')) - \sum_{v \in \bar{A}_x} (p(v|X) - p(v|X')) > 0. \quad (2)$$

For a directed tree  $G$ , the subgraph  $T_x := G[\text{cl}(x)]$  induced by the closure of  $x$  is a rooted directed tree with root  $x$ , where all the arcs are directed from  $x$  to the leaves (that is, an *out-tree*). Moreover, for a node  $v \in A_x$ , there is exactly one directed path from  $x$  to  $v$  in  $T_x$ . Let  $A'_x \subseteq A_x$  be the subset of target nodes  $v$  in the closure of  $x$  such that the directed path from  $x$  to  $v$  contains no other target node from  $A_x$ . Then, we can write the closure of  $x$  as the disjoint union  $\text{cl}(x) = \bigcup_{v \in A'_x} \text{cl}(v) \cup Z$ , where  $Z := \text{cl}(x) \setminus (\bigcup_{v \in A'_x} \text{cl}(v))$ . Note that  $Z \subseteq \bar{A}_x$ . Therefore, we can write Inequality (2) as

$$\begin{aligned} & \sum_{v \in A'_x} \left( \sum_{u \in A_v} (p(u|X) - p(u|X')) - \sum_{u \in \bar{A}_v} (p(u|X) - p(u|X')) \right) - \\ & \sum_{v \in Z} (p(v|X) - p(v|X')) > 0. \end{aligned}$$

Note that  $p(v|X) \geq p(v|X')$  holds for all  $v \in V$  since  $X' \subseteq X$ , which yields

$$\sum_{v \in Z} (p(v|X) - p(v|X')) \geq 0.$$

Therefore, the following holds

$$\sum_{v \in A'_x} \left( \sum_{u \in A_v} (p(u|X) - p(u|X')) - \sum_{u \in \bar{A}_v} (p(u|X) - p(u|X')) \right) > 0. \quad (3)$$

Now, let  $p(\bar{v}|X)$  denote the probability that a node  $v$  is not activated given that the nodes in  $X$  are active and let  $p(u|\bar{v}, X)$  be the probability of  $u$  being activated given that  $v$  is inactive and the nodes in  $X$  are active.

Note that, for  $v \in \text{cl}(x)$  and  $u \in \text{cl}(v)$ , the probability of  $u$  being active conditioned on  $v$  does not depend on  $x$  since  $v$  lies on the directed path from  $x$

to  $u$ , that is,  $p(u|v, X) = p(u|v, X')$  and  $p(u|\bar{v}, X) = p(u|\bar{v}, X')$ . Hence, we have

$$\begin{aligned} p(u|X) &= p(u|v, X)p(v|X) + p(u|\bar{v}, X)p(\bar{v}|X) \\ &= p(u|v, X')p(v|X) + p(u|\bar{v}, X')(1 - p(v|X)) \end{aligned}$$

and

$$p(u|X') = p(u|v, X')p(v|X') + p(u|\bar{v}, X')(1 - p(v|X')).$$

This yields

$$\begin{aligned} p(u|X) - p(u|X') &= p(u|v, X')(p(v|X) - p(v|X')) + p(u|\bar{v}, X')(p(v|X') - p(v|X)) \\ &= (p(v|X) - p(v|X'))(p(u|v, X') - p(u|\bar{v}, X')). \end{aligned}$$

Thus, for each  $v \in A'_x$ , we have

$$\begin{aligned} \sum_{u \in A_v} (p(u|X) - p(u|X')) - \sum_{u \in \bar{A}_v} (p(u|X) - p(u|X')) &= \\ (p(v|X) - p(v|X')) \left( \sum_{u \in A_v} (p(u|v, X') - p(u|\bar{v}, X')) - \sum_{u \in \bar{A}_v} (p(u|v, X') - p(u|\bar{v}, X')) \right). \end{aligned} \quad (4)$$

In the following, let

$$\delta_v(X') := \sum_{u \in A_v} (p(u|v, X') - p(u|\bar{v}, X')) - \sum_{u \in \bar{A}_v} (p(u|v, X') - p(u|\bar{v}, X')).$$

Consider now Inequality (3) again. Since the outer summation in Inequality (3) over all nodes  $v \in A'_x$  is positive, there must be some nodes  $v \in A'_x$  for which the summand (that is, the right-hand side product of Equation (4)) is positive. Note that  $p(v|X) - p(v|X') \geq 0$  since  $X' \subseteq X$  for all  $v \in A'_x$ . Hence, the set  $A^* := \{v \in A'_x \mid \delta_v(X') > 0\}$  is non-empty since these are the nodes for which the above product is positive. Furthermore, we define the new set of effectors  $X^* := X \setminus \{x\} \cup A^* = X' \cup A^*$ , which does not include the non-target node  $x$ .

Now, consider the difference  $C_A(G, X) - C_A(G, X^*)$ . Since  $\{x\} \cup A^* \subseteq \text{cl}(x)$ , it follows  $p(v|X) = p(v|X^*)$  for all  $v \notin \text{cl}(x)$ . Thus, analogously to the above steps, we can write  $C_A(G, X) - C_A(G, X^*)$  as

$$\begin{aligned} \sum_{v \in A'_x} \left( \sum_{u \in A_v} (p(u|X^*) - p(u|X)) - \sum_{u \in \bar{A}_v} (p(u|X^*) - p(u|X)) \right) - \\ \sum_{v \in Z} (p(v|X^*) - p(v|X)). \end{aligned}$$

Note that, for each  $v \in Z$ , it holds for all  $u \in A^*$  that  $v \notin \text{cl}(u)$ . Hence,  $p(v|X^*) = p(v|X')$ , which implies

$$\sum_{v \in Z} (p(v|X^*) - p(v|X)) \leq 0.$$

Thus, we obtain the following inequality

$$C_A(G, X) - C_A(G, X^*) \geq \sum_{v \in A'_x} \left( \sum_{u \in A_v} (p(u|X^*) - p(u|X)) - \sum_{u \in \bar{A}_v} (p(u|X^*) - p(u|X)) \right). \quad (5)$$

As in Equation (4), we can rewrite the right-hand side of Inequality (5) to

$$\sum_{v \in A'_x} (p(v|X^*) - p(v|X)) \left( \sum_{u \in A_v} (p(u|v, X) - p(u|\bar{v}, X)) - \sum_{u \in \bar{A}_v} (p(u|v, X) - p(u|\bar{v}, X)) \right). \quad (6)$$

Clearly, for  $v \in A'_x$ , the probability of  $u \in \text{cl}(v)$  being active conditioned on  $v$  does not depend on  $x$ , that is, it holds  $p(u|v, X) = p(u|v, X')$  and  $p(u|\bar{v}, X) = p(u|\bar{v}, X')$ . By substituting these probabilities into (6) we arrive at

$$C_A(G, X) - C_A(G, X^*) \geq \sum_{v \in A'_x} (p(v|X^*) - p(v|X)) \delta_v(X').$$

Now, for each node  $v \in A^*$ , it holds  $\delta_v(X') > 0$  and  $p(v|X^*) - p(v|X) = 1 - p(v|X) \geq 0$ , and thus  $(p(v|X^*) - p(v|X)) \delta_v(X') \geq 0$ . For each  $v \in A'_x \setminus A^*$ , it holds  $\delta_v(X') \leq 0$  and  $p(v|X^*) = p(v|X') \leq p(v|X)$ , and thus  $(p(v|X^*) - p(v|X)) \delta_v(X') \geq 0$ .

Hence,  $C_A(G, X) - C_A(G, X^*) \geq 0$  and, clearly,  $X^* \setminus A \subsetneq X \setminus A$ , and we are done.  $\square$

The last theorem shows that our model for the EFFECTORS problem and that of Lappas et al. [15] sometimes coincide. In general, however, it is not completely clear how the computational complexity of our model for the EFFECTORS problem differs from that of Lappas et al. [15]. We do *mention* that our algorithmic results (Lemma 1, Proposition 1, Theorem 5) easily transfer to the model of Lappas et al. [15], as well as Theorem 6.

#### 4 Computing the Cost Function

We consider the problem of computing the cost for a given set of effectors.

EFFECTORS-COST

**Input:** An influence graph  $G = (V, E, w)$ , a set of target nodes  $A \subseteq V$ , and a set of effectors  $X \subseteq V$ .

**Compute:** The cost  $C_A(G, X)$ .

EFFECTORS-COST is polynomial-time solvable on directed trees [15]. By contrast, EFFECTORS-COST is unlikely to be polynomial-time solvable even on DAGs. This follows from a result by Wang et al. [19, Theorem 1]. They show that computing the expected number of activated nodes for a single given effector is #P-hard on DAGs. Note that for the case  $A = \emptyset$  (that is,  $a = 0$ ), the cost equals the expected number of activated nodes at the end of the propagation process. Hence, we obtain the following corollary of Wang et al. [19].

**Corollary 1** *EFFECTORS-COST on directed acyclic graphs is #P-hard even for  $a = 0$  and  $|X| = 1$ .*

Note that Corollary 1 implies that EFFECTORS-COST on DAGs is not fixed-parameter tractable with respect to the combined parameter  $(a, |X|)$ .

On the positive side, EFFECTORS-COST is fixed-parameter tractable with respect to the number  $r$  of probabilistic arcs. The general idea is to recursively simulate the propagation process, branching over the probabilistic arcs, and to compute a weighted average of the final activation state of the graph.

**Theorem 2** *Given an instance  $(G = (V, E), A, X)$  of EFFECTORS-COST, the probability  $p(v|X)$  for a given node  $v \in V$  can be computed in  $O(2^r \cdot n(n+m))$  time, where  $r$  is the number of probabilistic arcs.*

*Accordingly, EFFECTORS-COST can be solved in  $O(2^r \cdot n^2(n+m))$  time.*

*Proof* The overall idea of the proof is as follows. For each subset of the probabilistic arcs, we compute the cost, conditioned on the event that the propagation process was successful on these arcs, but not successful on the other probabilistic arcs. For each such subset we also compute the probability that this event happens. Then, by applying the law of total probability, it follows that the overall cost equals the weighted average of these conditioned costs, weighted by the probability of these events.

We present the algorithm in a recursive way, mainly for the sake of having a formal proof for its correctness. To this end, let  $(G = (V, E), A, X)$  be an input instance of EFFECTORS-COST. Note that in order to compute the cost  $C_A(G, X)$ , we compute the probability  $p(v|X)$  for each node  $v \in V$ , because given all these probabilities it is straightforward to compute the cost in polynomial time. Hence, we prove the theorem by showing that computing  $p(v|X)$  is fixed-parameter tractable with respect to  $r$  using a search-tree algorithm that computes  $p(v|X)$  for a given node  $v$  by recursively “simulating” all possible scenarios which could appear during the propagation process.

To this end, we define an auxiliary function  $\tilde{p}(v, X, F)$  denoting the probability that  $v$  is activated during the propagation process given that exactly the nodes in  $X$  are active but only the nodes in  $F \subseteq X$  are allowed to activate further nodes in the next step, whereas the nodes in  $X \setminus F$  can never activate any other node (indeed,  $p(v|X) = \tilde{p}(v, X, X)$ ).

We now show how to compute  $\tilde{p}(v, X, F)$ . First, if  $v \in X$ , then  $\tilde{p}(v, X, F) = 1$ , as it is already activated. Otherwise, if  $v \notin X$  and  $F$  is closed (that is,  $F$

---

**Algorithm 1:** Pseudocode for  $\tilde{p}(v, X, X)$ .

---

```

if  $v \in X$  then
  return 1
if  $v \notin X$  and  $X$  is closed then
  return 0
foreach  $R \subseteq N_p$  do
  compute  $q(X_R|X)$ 
  compute  $\tilde{p}(v, X_R, F_R)$  recursively
return  $\sum_{R \subseteq N_p} q(X_R|X) \cdot \tilde{p}(v, X_R, F_R)$ 

```

---

has no outgoing arcs to  $V \setminus X$ ), then there is no propagation at all and thus  $\tilde{p}(v, X, F) = 0$ . Otherwise, if  $X$  is not closed, then let  $N \subseteq V \setminus X$  denote the set of nodes in  $V \setminus X$  that have an incoming arc from some node in  $F$ . Further, let  $N_d \subseteq N$  be the set of nodes that have at least one deterministic incoming arc from  $F$ , and let  $N_p := N \setminus N_d$ . Also, let  $E_p \subseteq E$  be the set of probabilistic arcs from  $F$  to  $N$ . Clearly, all nodes in  $N_d$  will be active in the next step of the propagation process, while the nodes in  $N_p$  will be active in the next step only with some positive probability. We can use the law of total probability on the subsets of  $N_p$ , and write

$$\tilde{p}(v, X, F) = \sum_{R \subseteq N_p} \tilde{p}(v, X_R, F_R) q(X_R|X),$$

where  $X_R := X \cup F_R$  denotes the set of active nodes in the next time step,  $F_R := N_d \cup R$  denotes the set of newly active nodes in the next time step, and  $q(X_R|X)$  denotes the probability that *exactly* the nodes in  $X_R$  are active in the next step given that *exactly* the nodes in  $X$  are active. Note that, for each subset  $R \subseteq N_p$ ,

$$q(X_R|X) = \prod_{u \in R} (1 - \bar{p}_u) \prod_{u \in N_p \setminus R} \bar{p}_u, \text{ where } \bar{p}_u := \prod_{v \rightarrow u \in E_p} (1 - w(v \rightarrow u)),$$

is polynomial-time computable. As a result, we end up with the following recursive formula:

$$\tilde{p}(v, X, F) := \begin{cases} 1, & \text{if } v \in X \\ 0, & \text{if } v \notin X \text{ and } X \text{ closed} \\ \sum_{R \subseteq N_p} q(X_R|X) \cdot \tilde{p}(v, X_R, F_R), & \text{else.} \end{cases}$$

Algorithm 1 presents the pseudocode for computing  $\tilde{p}$ . For the running time, consider the recursion tree corresponding to the computation of  $\tilde{p}(v, X, X)$ , where each vertex corresponds to a call of  $\tilde{p}$ .

For the running time, note that the inner computation (that is, without further recursive calls) of each node in the recursion tree can be done in time  $O(n + m)$ . Moreover, for each call, either at least one node is inserted to  $X$ ,

or the recursion stops. Therefore, the height of the recursion tree is upper-bounded by the number  $n$  of nodes. Lastly, each leaf in the recursion tree corresponds to a distinct subset of the probabilistic arcs, specifically, to those probabilistic arcs along which the propagation process carried on. Since there are  $2^r$  different subsets of probabilistic arcs, it follows that the number of leaves of the recursion tree is upper-bounded by  $2^r$ . Thus, the overall size of the recursion tree is upper-bounded by  $2^r \cdot n$ , and hence, the running time is  $O(2^r \cdot n(n + m))$ .  $\square$

## 5 Finding Effectors

We treat the general variant of EFFECTORS in Section 5.1, the special case of unlimited budget in Section 5.2, and the special case of influence maximization in Section 5.3.

### 5.1 General Model

We study how the parameters number  $a$  of target nodes, budget  $b$ , and cost value  $c$  influence the computational complexity of EFFECTORS. We first observe that if at least one of them equals zero, then EFFECTORS is polynomial-time solvable. This holds trivially for parameters  $a$  and  $b$ ; simply choose the empty set as a solution. This is optimal for  $a = 0$ , and the only feasible solution for  $b = 0$ . For parameter  $c$ , the following holds, using a simple decomposition into strongly connected components.

**Lemma 1** *For  $c = 0$ , EFFECTORS can be solved in linear time.*

*Proof* If there is a directed path from a target node to a non-target node, then we have a “no”-instance. Now every target node must be activated with probability 1, which is only possible along deterministic arcs. Let  $G'$  be the condensation (that is, the DAG of strongly connected components) of the influence graph  $G$  after removing all probabilistic arcs. Then, we consider only the strongly connected components which contain at least one target node (note that all nodes in this component must be targets). Finally, if there are more than  $b$  of these target components that are sources in  $G'$ , then we have a “no”-instance. Otherwise, we arbitrarily pick a node from each component corresponding to a source, and return a positive answer. Each step requires linear time.  $\square$

Based on Lemma 1, by basically checking all possibilities in a brute-force manner, we obtain simple polynomial-time algorithms for EFFECTORS in the cases of a constant number  $a$  of target nodes, budget  $b$ , or cost  $c$ .

**Proposition 1** *For  $r = 0$ , EFFECTORS is in XP with respect to each of the parameters  $a$ ,  $b$ , and  $c$ .*



*Proof* Containment in XP for the parameter  $b$  is straightforward: For each possible set of effectors, we compute the cost in linear time and then return the best set of effectors.

Note that for the case  $r = 0$ , we can assume that  $b \leq a$ . To see this, let  $X \subseteq V$  be a solution of size  $|X| > a$  and let  $A' \subseteq A$  be the subset of target nodes that are activated by choosing  $X$ . Clearly, choosing  $A'$  as effectors is a better solution since it activates the same target nodes and only activates a subset of the non-target nodes activated by  $X$ . Therefore, we also have containment in XP with respect to  $a$ .

It remains to show the claim for parameter  $c$ . First, we choose which  $c' \leq c$  nodes incur a cost. Among these nodes, we set the target nodes to be non-targets, and vice versa. Then, we run the polynomial-time algorithm of Lemma 1 with cost 0. We exhaustively try all possible  $\sum_{c'=0}^c \binom{n}{c'} \in O(n^c)$  choices to find a positive answer and return a negative answer otherwise.  $\square$

In the following, we show that, even for  $r = 0$  and the influence graph being a DAG, EFFECTORS is W[1]-hard with respect to the *combined* parameter  $(a, b, c)$ , and even W[2]-hard with respect to the *combined* parameter  $(b, c)$ .

### Theorem 3

1. EFFECTORS, parameterized by the combined parameter  $(a, b, c)$ , is W[1]-hard, even if  $r = 0$  and the influence graph is a DAG.
2. EFFECTORS, parameterized by the combined parameter  $(b, c)$ , is W[2]-hard, even if  $r = 0$  and the influence graph is a DAG.

*Proof* We begin with the first statement, namely, that EFFECTORS, parameterized by the combined parameter  $(a, b, c)$ , is W[1]-hard, even if  $r = 0$  and  $G$  is a DAG. We describe a parameterized reduction from the following W[1]-hard problem [12].

#### MULTI-COLORED CLIQUE

**Input:** A simple and undirected graph  $G = (V, E)$  with  $k$  colors on the vertices and  $k \in \mathbb{N}$ .

**Question:** Is there a  $k$ -vertex clique with exactly one occurrence of each color in the clique?

Consider an instance  $(G = (V, E), k)$  of MULTI-COLORED CLIQUE. We assume that  $k > 1$ , otherwise the instance can be solved trivially. We construct an instance of EFFECTORS with  $b = \binom{k}{2}$ ,  $c = \binom{k}{2} + k$  and an influence graph (see Figure 3 for an illustration) defined as follows. Add  $\binom{k}{2} + k + 1$  nodes for each unordered pair of distinct colors. Let us call these nodes *color-pair nodes*. These color-pair nodes are the target nodes  $A$ , thus  $a = \binom{k}{2} \cdot (\binom{k}{2} + k + 1)$ . Now, add a *vertex node*  $n_v$  for each  $v \in V$ , add an *edge node*  $e_{u,v}$  for each  $e = \{u, v\} \in E$ , and add arcs  $\{e_{u,v} \rightarrow n_u, e_{u,v} \rightarrow n_v\}$ . For each edge  $e = \{u, v\} \in E$ , let  $L_e$  be the color-pair nodes corresponding to the colors of  $u$  and  $v$  and add arcs  $\{e_{u,v} \rightarrow \ell \mid \ell \in L_e\}$ . Finally, set the influence weights of all arcs to 1.

Let  $G'$  be the influence graph obtained by the above construction and notice that  $G'$  is a DAG. We show that there is a  $k$ -vertex multi-colored clique

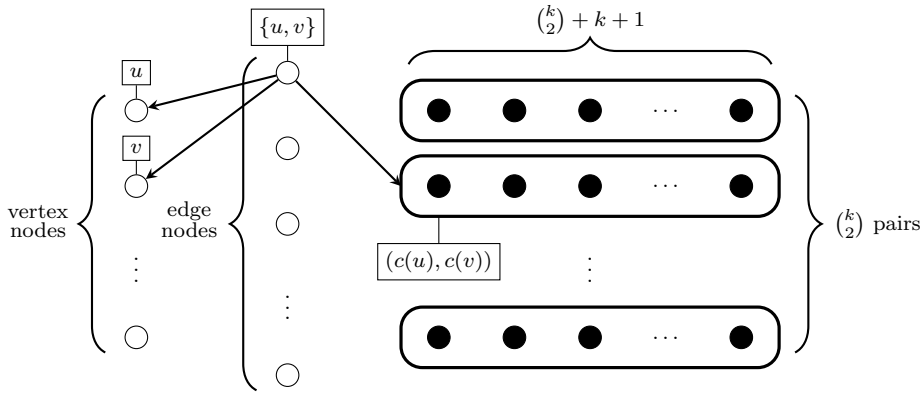

**Fig. 3** Illustration of the influence graph used in the reduction from MULTI-COLORED CLIQUE. In this example arcs are shown for one of the edge nodes. An arc from an edge node to a set of color pair nodes is used to represent the  $\binom{k}{2} + k + 1$  arcs to all nodes for this color pair. All arcs have an influence weight of 1.

in  $G$  if and only if there is a size- $b$  set of effectors that incurs a cost of at most  $c$  in  $G'$ .

Suppose that there is a multi-colored clique with  $k$  vertices in  $G$ . Let  $X$  be the edge nodes corresponding to the edges of this clique. Clearly,  $|X| = \binom{k}{2} = b$ . These effectors activate all color-pair nodes, that is, the complete target set  $A$  with probability 1. Furthermore, the non-active edge and vertex nodes corresponding to the clique are activated, and a total cost of  $\binom{k}{2} + k = c$  is incurred.

For the reverse direction, let  $X$  be a size- $b$  set of effectors that incurs a cost of at most  $c$  in  $G'$ . Directly picking a vertex node is not optimal, since they are non-target nodes without outgoing arcs. Hence, they can only increase the cost. Also, without loss of generality, we can assume that  $X$  does not contain a color-pair node  $x$ . To see this, assume the contrary and suppose that  $X$  contains at least one edge node which influences  $x$ . Then  $X \setminus \{x\}$  is a solution with equivalent cost and smaller budget. In the other case, suppose that no such edge node is in  $X$ . Then, we pay for at least  $k + 1$  other nodes corresponding to the same color-pair as  $x$  since we can only take  $b = \binom{k}{2}$  out of  $\binom{k}{2} + k + 1$  nodes. Directly picking an edge node instead of  $x$  incurs a cost of at most 3. By assumption,  $k > 1$ , that is, any optimal solution can be replaced by one that chooses only edge nodes as effectors. Now, in order to avoid a cost higher than  $\binom{k}{2} + k = c$ , every color-pair node must be directly activated by an edge node. Then  $X$  must contain exactly  $\binom{k}{2}$  edge nodes, one for each color pair. A cost of at most  $\binom{k}{2} + k$  is only obtained if they activate at most  $k$  vertex nodes, i.e., the edges corresponding to the chosen edge nodes must form a multi-colored clique with  $k$  vertices.

We continue with the second statement, namely, that EFFECTORS, parameterized by the combined parameter  $(b, c)$ , is  $W[2]$ -hard, even if  $r = 0$  and  $G$  is

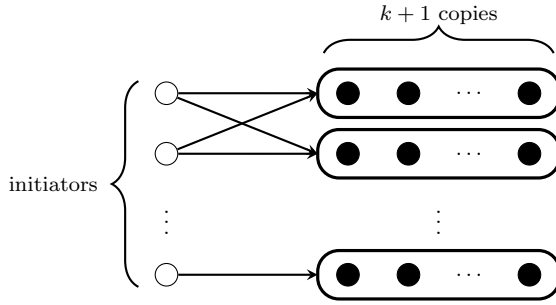

**Fig. 4** Illustration of the influence graph in the reduction from DOMINATING SET. The vertices corresponding to the two initiators at the top are neighbors in the input graph. An arc from an initiator to a set of copies is used to represent  $k + 1$  arcs, one to each copy. All arcs have an influence weight of 1.

a DAG. We provide a parameterized reduction from the  $W[2]$ -complete DOMINATING SET problem [11].

#### DOMINATING SET

**Input:** A simple and undirected graph  $G = (V, E)$ ,  $k \in \mathbb{N}$ .

**Question:** Is there a vertex subset  $D \subseteq V$  such that  $|D| \leq k$  and for each  $v \in V$  either  $v \in D$  or  $\exists v' \in D$  such that  $\{v, v'\} \in E$ ?

Consider an instance  $(G = (V, E), k)$  of DOMINATING SET. We construct an instance for EFFECTORS with  $b = c = k$ , and obtain the influence graph (see Figure 4 for an illustration) as follows: Add a node  $i_v$  and a set of nodes  $\{c_{v,1}, \dots, c_{v,k+1}\}$  for each vertex  $v \in V$ . Let us call these the *initiator* and *copies* of  $v$ , respectively. We connect each initiator of  $v$  to all of its copies by adding arcs  $\{i_v \rightarrow c_{v,1}, \dots, i_v \rightarrow c_{v,k+1}\}$ . In a similar fashion, for each edge  $\{u, v\} \in E$ , we connect the initiator of  $u$  to all copies of  $v$  and vice versa. Finally, let the set of target nodes  $A$  contain all copies of vertices and set the influence weight of all arcs to 1.

Let  $G'$  be the influence graph obtained in the construction and note that  $G'$  is a DAG. We show that there is a size- $k$  set  $D$  that dominates all vertices in  $G$  if and only if there is a size- $k$  set  $X$  of effectors that incurs a cost of at most  $k$  in  $G'$ . Suppose that  $D$  is a  $k$ -dominating set for  $G$ . Let  $X$  be the initiators of vertices in  $D$ . These effectors activate all copies of vertices, i.e., the complete target set  $A$  with probability 1. Clearly,  $|X| = k = b$  and a cost of  $k = c$  is incurred for picking the initiators as effectors.

For the reverse direction, let  $X$  be a size- $k$  set of effectors that incur a cost of at most  $k$  in  $G'$ . Consider a solution in which we directly pick a copy  $x$  of a vertex  $v$  as an effector. Suppose that  $X$  contains the initiator of  $v$  or one of its neighbors. Then  $X \setminus \{x\}$  is a solution with equivalent cost and smaller budget. In the other case, suppose that  $X$  contains no such initiator. Then, we pay for at least one other copy of  $v$  since we can take at most  $k$  out of  $k + 1$  copies. Therefore, any optimal solution can be replaced by one that chooses only initiators as effectors. Now, every copy must be directly

activated by an initiator to avoid a cost higher than  $k$ . Furthermore,  $X$  can contain at most  $k$  initiators. These initiators can only influence copies of their corresponding vertex or its neighbors, that is, the vertices corresponding to the chosen initiators are a  $k$ -dominating set.  $\square$

## 5.2 Special Case: Unlimited Budget

Here, we concentrate on a model variant where we are allowed to choose any number of effectors, that is, the goal is to minimize the overall cost with an unlimited budget of effectors. In general, EFFECTORS with unlimited budget remains intractable, though.

**Theorem 4** *If  $P \neq NP$ , then EFFECTORS, even with unlimited budget, is not polynomial-time solvable on DAGs.*

*Proof* We consider the following #P-hard [18] counting problem.

S-T CONNECTEDNESS

**Input:** A directed acyclic graph  $G = (V, E)$ , two vertices  $s, t \in V$ .

**Compute:** Number of subgraphs of  $G$  in which there is a directed path from  $s$  to  $t$ .

In the following, let  $\#_{st}(G)$  denote the number of subgraphs of  $G$  in which there exists a directed path from  $s$  to  $t$  (where distinct isomorphic subgraphs are considered different). We give a polynomial-time reduction from the decision version of S-T CONNECTEDNESS, which asks whether  $\#_{st}(G)$  is at least a given integer  $z$ .

Let  $I = (G = (V, E), s, t, z)$  be an instance of the decision version of S-T CONNECTEDNESS. We create an EFFECTORS instance  $I' = (G' = (V', E', w), A, b, c)$  as follows. Let  $V_{st} \subseteq V$  be the set of vertices that lie on some directed path from  $s$  to  $t$  and let  $E_{st} \subseteq E$  be the set of arcs of all directed paths from  $s$  to  $t$ . Further, let  $W := V_{st} \setminus \{s, t\}$ . Clearly, it holds  $\#_{st}(G) = \#_{st}(G[V_{st}]) \cdot 2^{|E \setminus E_{st}|}$  since  $\#_{st}(G[V \setminus V_{st}]) = 0$ . Thus, in order to decide whether  $\#_{st}(G) \geq z$ , we have to decide whether  $\#_{st}(G[V_{st}]) \geq z'$ , where  $z' := \lceil z \cdot 2^{-|E \setminus E_{st}|} \rceil$ .

We initialize  $G'$  as the induced subgraph  $G[V_{st}]$  and set  $w(v \rightarrow u) := 1/2$  for each  $v \rightarrow u \in E_{st}$ . We further create a copy  $v'$  for each vertex  $v \in W$ , and add the arc  $v \rightarrow v'$  with  $w(v \rightarrow v') := 1$ . We also create a copy  $s'$  of  $s$ , and add the arc  $s \rightarrow s'$  with  $w(s \rightarrow s') := 1 - p_{z'}$ , where  $p_{z'} := z' \cdot 2^{-|E_{st}|}$ . Finally, we set  $A := W \cup \{s\}$ ,  $b = \infty$ , and  $c := |W| + 1 - 2^{-|E_{st}|}$ . The construction is illustrated in Figure 5.

In the following, we prove two claims used to show the correctness of the above reduction. First, we claim that an optimal solution  $X$  of  $I'$  either equals  $\emptyset$  or  $\{s\}$ . This can be seen as follows. Choosing  $s'$ ,  $t$ , or any copy  $v'$  to be an effector is never optimal as these are all non-target nodes without outgoing

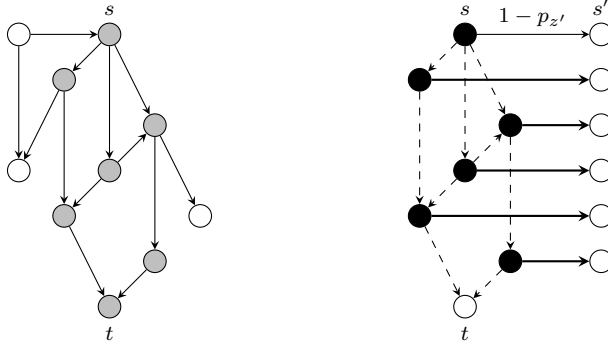

**Fig. 5** Example illustrating the construction in the proof of Theorem 4. Left: A directed acyclic graph with two distinguished vertices  $s$  and  $t$ , where the gray vertices lie on a directed  $s$ - $t$ -path. Right: The corresponding influence graph with target nodes colored in black. Dashed arcs have an influence weight of  $1/2$  and thick arcs have an influence weight of  $1$ .

arcs. Now, assume that  $X$  contains a node  $v \in W$  and let  $X' := X \setminus \{v\}$ . Then, we have

$$\begin{aligned} C_A(G', X) - C_A(G', X') &= p(s|X') - p(s|X) + p(s'|X) - p(s'|X') + \\ &\quad \sum_{u \in W} (p(u|X') - p(u|X) + p(u'|X) - p(u'|X')) + \\ &\quad p(t|X) - p(t|X'). \end{aligned}$$

Since  $G'$  is a DAG, it holds that there is no directed path from  $v$  to  $s$  and thus  $p(s|X') = p(s|X)$  and consequently also  $p(s'|X') = p(s'|X)$ . Moreover, note that  $p(u|X) = p(u'|X)$  and  $p(u|X') = p(u'|X')$  holds for all  $u \in W$ , and  $p(t|X) \geq p(t|X')$  clearly holds since  $X' \subseteq X$ . Hence,  $C_A(G', X) - C_A(G', X') \geq 0$  and therefore  $X'$  is also an optimal solution not containing  $v$ , which proves the claim.

Next, we claim that  $p(t|\{s\}) = \#_{st}(G'[V_{st}]) \cdot 2^{-|E_{st}|}$ . To prove this, we define an  $s$ - $t$ -scenario  $S \subseteq E_{st}$  to be a subset of arcs such that  $\{s, t\} \subseteq V(S)$  and there is a directed path from  $s$  to each  $v \in V(S)$  in  $G[S]$ . Let  $S^* := \{v \rightarrow u \in E_{st} \mid v \in V(S)\}$  denote the set of all outgoing arcs from nodes in  $V(S)$ . We denote the set of all  $s$ - $t$ -scenarios by  $\mathcal{S}_{st}$ . Note that each scenario  $S$  constitutes a possible propagation in which exactly the arcs in  $S$  activated their endpoints and the arcs in  $S^* \setminus S$  did not activate their endpoints. The probability  $q(S)$  for a given  $s$ - $t$ -scenario  $S$  to occur is thus  $2^{-|S^*|}$ . Clearly, we can write

$$p(t|\{s\}) = \sum_{S \in \mathcal{S}_{st}} q(S) = \sum_{S \in \mathcal{S}_{st}} 2^{-|S^*|} = 2^{-|E_{st}|} \cdot \sum_{S \in \mathcal{S}_{st}} 2^{|E_{st} \setminus S^*|}.$$

Now, for a subset  $F \subseteq E_{st}$  of arcs where  $s$  is connected to  $t$  in the subgraph  $G'[F]$ , let  $sc(F)$  denote the scenario  $S \in \mathcal{S}_{st}$  where  $S \subseteq F$  and  $S \not\subseteq S'$  for all  $S' \neq S \in \mathcal{S}_{st}$  such that  $S' \subseteq F$ . It holds that  $F = S \cup F^*$ , where  $S := sc(F)$

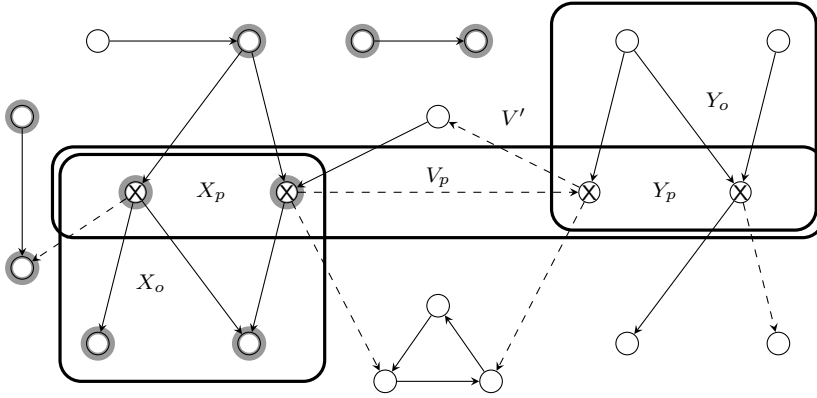

**Fig. 6** Illustration for Theorem 5. Effectors of a solution are marked with an aura. Probabilistic arcs are dashed, and nodes of  $V_p$  (with an outgoing probabilistic arc) are marked with a cross. For readability, target nodes are not represented. Intuitively, the algorithm guesses the partition of  $V_p$  into  $X_p$  (effectors) and  $Y_p$  (non-effectors). Node set  $X_p$  (respectively,  $Y_p$ ) is then extended to its closure  $X_o$  (respectively, its closure  $Y_o$  in the reverse graph). The remaining nodes form a deterministic subgraph  $G[V']$ , in which effectors, forming the set  $X'$ , are selected by solving an instance of MAXIMUM WEIGHT CLOSURE.

and  $F^* := F \setminus S \subseteq E_{st} \setminus S^*$ . Hence, we have  $\#_{st}(G'[V_{st}]) = \sum_{S \subseteq S_{st}} 2^{|E_{st} \setminus S^*|}$ , which proves the claim.

We now decide the instance  $I$  as follows. Note that  $C_A(G', \emptyset) = |W| + 1$  and  $C_A(G', \{s\}) = |W| + 1 - p_{z'} + p(t|\{s\})$ . Therefore, if  $I'$  is a “yes”-instance, then  $\{s\}$  is the optimal solution with  $|W| + 1 - p_{z'} + p(t|\{s\}) \leq c = |W| + 1 - 2^{-|E_{st}|}$ , which implies  $p_{z'} - p(t|\{s\}) \geq 2^{-|E_{st}|}$ . It follows that  $\#_{st}(G'[V_{st}]) < z'$ . Therefore,  $I$  is a “no”-instance. If  $I'$  is a “no”-instance, then  $p_{z'} - p(t|\{s\}) < 2^{-|E_{st}|}$ , which implies  $\#_{st}(G'[V_{st}]) \geq z'$ , hence  $I$  is a “yes”-instance.  $\square$

With unlimited budget, however, EFFECTORS becomes fixed-parameter tractable with respect to the parameter number  $r$  of probabilistic arcs.

**Theorem 5** *If  $b = \infty$ , then EFFECTORS is solvable in  $O(4^r \cdot n^4)$  time, where  $r$  is the number of probabilistic arcs.*

*Proof* The general idea is to fully determine the probabilistic aspects of the graph, and then to remove all of the corresponding nodes and arcs. We can show that this leaves an equivalent “deterministic graph” that we can solve using a reduction to the problem MAXIMUM WEIGHT CLOSURE, which is itself polynomial-time solvable by a polynomial-time reduction to a flow maximization problem [1, Chapter 19].

MAXIMUM WEIGHT CLOSURE

**Input:** A directed graph  $G = (V, E)$  with weights on the vertices.

**Compute:** A maximum-weight set of vertices  $X \subseteq V$  with no arcs going out of the set.

We start with some notation (see Figure 6 for an illustration). For an input graph  $G = (V, E)$ , let  $E_p := \{u \rightarrow v \in E \mid w(u \rightarrow v) < 1\}$  denote the

set of probabilistic arcs and let  $V_p := \{u \mid u \rightarrow v \in E_p\}$  denote the set of nodes with at least one outgoing probabilistic arc. For a node  $v \in V$ , let  $\text{cl}_{\text{det}}(v)$  ( $\text{cl}_{\text{det}}^{-1}(v)$ ) denote the set of all nodes  $u$  such that there exists at least one deterministic path from  $v$  to  $u$  (respectively, from  $u$  to  $v$ ), where a deterministic path is a path containing only deterministic arcs. We extend the notation to subsets  $V'$  of  $V$  and write  $\text{cl}_{\text{det}}(V') = \bigcup_{v \in V'} \text{cl}_{\text{det}}(v)$  and  $\text{cl}_{\text{det}}^{-1}(V') = \bigcup_{v \in V'} \text{cl}_{\text{det}}^{-1}(v)$ . We call a subset  $V' \subseteq V$  of nodes *deterministically closed* if and only if  $\text{cl}_{\text{det}}(V') = V'$ , that is, there are no outgoing deterministic arcs from  $V'$  to  $V \setminus V'$ .

Our algorithm will be based on a closer analysis of the structure of an optimal solution. To this end, let  $G = (V, E, w)$  be an input graph with a set  $A \subseteq V$  of target nodes and let  $X \subseteq V$  be an optimal solution with minimum cost  $C_A(G, X)$ . Clearly, we can assume that  $X$  is deterministically closed, that is,  $\text{cl}_{\text{det}}(X) = X$ , since we have an infinite budget  $b = \infty$ .

We write  $V_p$  as a disjoint union of  $X_p := V_p \cap X$  and  $Y_p := V_p \setminus X$ . We also use  $X_o := \text{cl}_{\text{det}}(X_p)$ ,  $Y_o := \text{cl}_{\text{det}}^{-1}(Y_p)$ , and  $V_o = X_o \cup Y_o$ . Since  $X$  is deterministically closed, we have that  $X_o \subseteq X$  and  $Y_o \cap X = \emptyset$ . We write  $V' := V \setminus V_o$  and  $X' := X \setminus X_o = X \cap V'$ . Note that  $X'$  is deterministically closed in  $G[V']$  and that  $G[V']$  contains only deterministic arcs. Moreover, note that the sets  $X_o, Y_p, Y_o, V_o$ , and  $V'$ , are directly deduced from the choice of  $X_p$ , and that for a given  $X_p$ , the set  $X'$  can be any deterministically closed subset of  $V'$ .

We first show that the nodes in  $V_o$  are only influenced by effectors in  $X_o$ , that is, for any node  $v \in V_o$ , it holds that  $p(v|X) = p(v|X_o)$ . This is clear for  $v \in X_o$ , since in this case  $p(v|X) = p(v|X_o) = 1$ . Assume now that there is a node  $x \in X'$  with a directed path to  $v \in Y_o$  that does not contain any node from  $X_o$  (if every directed path from  $x$  to  $v$  passes through  $X_o$ , then clearly  $x$  does not influence  $v$ ). Two cases are possible, depending on whether this path is deterministic. If it is, then, since  $v \in \text{cl}_{\text{det}}^{-1}(Y_p)$ , there exists a deterministic path from  $x$  to some  $u \in Y_p$ , via  $v$ . Hence,  $x \in \text{cl}_{\text{det}}^{-1}(Y_p) = Y_o$ , yielding a contradiction. Assume now that the path from  $x$  to  $v$  has a probabilistic arc and write  $u \rightarrow u'$  for the first such arc. Hence,  $x \in \text{cl}_{\text{det}}^{-1}(u)$  and  $u \in V_p$ . Since we assumed that the path does not contain any node from  $X_o$ , we have  $u \notin X_p$ , and therefore  $u \in Y_p$ . Again, we have  $x \in \text{cl}_{\text{det}}^{-1}(Y_p)$ , yielding a contradiction. Hence, the nodes in  $V_o$  are not influenced by the nodes in  $X'$ .

Now consider the nodes in  $V'$ . Note that we have  $p(v|X) = 1$  for  $v \in X'$  and  $p(v|X) = p(v|X_o)$  for  $v \in V' \setminus X'$ , since  $G[V']$  is deterministic and  $X'$  is deterministically closed. Overall,  $C_A(v, X) = C_A(v, X_o)$  for all  $v \in V \setminus X'$ . The total cost of solution  $X$  can now be written as

$$\begin{aligned} C_A(G, X) &= \sum_{v \in V \setminus X'} C_A(v, X_o) + \sum_{v \in X'} C_A(v, X) \\ &= \sum_{v \in V} C_A(v, X_o) - \sum_{v \in X'} (C_A(v, X_o) - C_A(v, X)) \\ &= \alpha(X_o) - \beta(X_o, X'), \end{aligned}$$

---

**Algorithm 2:** Pseudocode for EFFECTORS with  $b = \infty$ .
 

---

```

foreach  $X_p \subseteq V_p$  do
  compute  $X_o := \text{cl}_{\text{det}}(X_p)$ 
  compute  $Y_o := \text{cl}_{\text{det}}^{-1}(V_p \setminus X_p)$ 
  foreach  $v \in V$  do
    compute  $p(v|X_o)$  (using Theorem 2) and  $\gamma(v, X_o)$ 
  compute  $\alpha(X_o)$ 
  compute  $X'$  maximizing  $\beta(X_o, X')$  using MAXIMUM WEIGHT
  CLOSURE on  $G[V']$ , with weights  $\gamma(v, X_o)$ 
return the  $X_o \cup X'$  which gives the minimum  $\alpha(X_o) - \beta(X_o, X')$ 

```

---

where

$$\alpha(X_o) := \sum_{v \in V} C_A(v, X_o) \quad \text{and} \quad \beta(X_o, X') := \sum_{v \in X'} (C_A(v, X_o) - C_A(v, X)).$$

We further define, for all  $v \in V'$ ,  $\gamma(v, X_o) := 1 - p(v|X_o)$  if  $v \in A$ , and  $\gamma(v, X_o) = p(v|X_o) - 1$  if  $v \notin A$ . Note that, for  $v \in X'$ , the difference  $C_A(v, X_o) - C_A(v, X)$  is exactly  $\gamma(v, X_o)$ , hence  $\beta(X_o, X') = \sum_{v \in X'} \gamma(v, X_o)$ .

The algorithm can now be described directly based on the above formulas. Specifically, we branch over all subsets  $X_p \subseteq V_p$  (note that the number of these subsets is upper-bounded by  $2^r$ ). For each such subset  $X_p \subseteq V_p$ , we can compute  $X_o$  and  $Y_o$  in linear time because this involves propagation only through deterministic arcs (outgoing for  $X_o$  and ingoing for  $Y_o$ ). Then, for each node  $v \in V$ , we compute  $p(v|X_o)$  using Theorem 2 in  $O(2^r \cdot n(n+m))$  time. This yields the values  $\alpha(X_o)$  and  $\gamma(v, X_o)$  for each  $v \in V'$ . By the discussion above, it remains to select a closed subset  $X' \subseteq V'$  such that the cost  $C_A(G, X_o \cup X') = \alpha(X_o) - \beta(X_o, X')$  is minimized. That is, we have to select the subset  $X'$  that maximizes the value of  $\beta(X_o, X')$ . Hence, the subset  $X'$  can be computed as the solution of MAXIMUM WEIGHT CLOSURE on  $G[V']$  (which is solved by a maximum flow computation in  $O(n^3)$  time), where the weight of any  $v \in V'$  is  $\gamma(v, X_o)$ . Finally, we return the set  $X_o \cup X'$  that yields the minimum cost  $\alpha(X_o) - \beta(X_o, X')$ . A pseudocode is given in Algorithm 2.  $\square$

### 5.3 Special Case: Influence Maximization

In this section, we consider the special case of EFFECTORS, called INFLUENCE MAXIMIZATION, where all nodes are targets ( $A = V$ ). Note that in this case the variant with unlimited budget and the parameterization by the number of target nodes are irrelevant.

In the influence maximization case, on deterministic instances, one should intuitively choose effectors among the ‘‘sources’’ of the influence graph, that is, nodes without incoming arcs (or among strongly connected components



without incoming arcs). Moreover, the budget  $b$  bounds the number of sources that can be selected, and the cost  $c$  bounds the number of sources that can be left out. In the following theorem, we prove that deterministic EFFECTORS remains intractable even if either one of these parameters is small, but, by contrast, having  $b + c$  as a parameter yields fixed-parameter tractability in the deterministic case. We mention that the first statement is proven by a reduction from the  $W[2]$ -hard SET COVER problem, while the second statement is proven by a reduction from the  $W[1]$ -hard INDEPENDENT SET problem.

### Theorem 6

1. INFLUENCE MAXIMIZATION, parameterized by the maximum number  $b$  of effectors, is  $W[2]$ -hard, even if  $G$  is a deterministic ( $r = 0$ ) DAG.
2. INFLUENCE MAXIMIZATION, parameterized by the cost  $c$ , is  $W[1]$ -hard, even if  $G$  is a deterministic ( $r = 0$ ) DAG.
3. If  $r = 0$ , then INFLUENCE MAXIMIZATION can be solved in  $O\left(\binom{b+c}{b} \cdot (n+m)\right)$  time.

*Proof* We begin with the first statement, namely, that INFLUENCE MAXIMIZATION (which is equivalent to EFFECTORS where all nodes are target nodes, that is, where  $A = V$ ), parameterized by the maximum number  $b$  of effectors, is  $W[2]$ -hard, even if  $G$  is a deterministic ( $r = 0$ ) DAG. We provide a parameterized reduction from the  $W[2]$ -complete SET COVER problem [11].

#### SET COVER

**Input:** Sets  $S = \{S_1, \dots, S_m\}$  over elements  $U = \{u_1, \dots, u_n\}$ , and parameter  $h \in \mathbb{N}$ .

**Question:** Is there  $S' \subseteq S$  such that  $|S'| = h$  and  $\bigcup_{S_i \in S'} S_i = U$ ?

Given an instance for SET COVER, we create an instance for INFLUENCE MAXIMIZATION as follows. Add a node  $v_{S_j}$  for each set  $S_j$  and write  $V_S = \{v_{S_i} \mid S_i \in S\}$ . Add a node  $v_{u_i}$  for each element  $u_i$  and write  $V_U = \{v_{u_i} \mid u_i \in U\}$ . For each  $u_i \in S_j$ , add an arc  $v_{S_j} \rightarrow v_{u_i}$  with influence probability 1. Set  $b := h$ ,  $c := m - h$ , and  $A := V_S \cup V_U$ .

We can assume that any solution  $X$  is such that  $X \subseteq V_S$  and  $|X| = b$ . Note that all nodes of  $V_U$  are activated if and only if  $S' := \{S_i \mid v_{S_i} \in X\}$  is a set cover for  $U$ . Hence, any solution with cost  $c = |V_S \setminus X| = m - b$  needs to pay only for the unselected nodes of  $V_S$ , and yields a set cover of  $U$ . Reversely, for any set cover  $S'$  for  $U$  of size  $h$ , the set  $X := \{v_{S_i} \mid S_i \in S'\}$  is a set of effectors with cost at most  $c$ .

We continue with the second statement, namely, that INFLUENCE MAXIMIZATION, parameterized by the cost  $c$ , is  $W[1]$ -hard, even if  $G$  is a deterministic ( $r = 0$ ) DAG. We provide a reduction from the following  $W[1]$ -complete problem [11].

#### INDEPENDENT SET

**Input:** An undirected graph  $G = (V, E)$  and parameter  $k \in \mathbb{N}$ .

**Question:** Is there an independent set  $I \subseteq V$  (i.e., no edge has both endpoints in  $I$ ) such that  $|I| \geq k$ ?

Consider an instance  $(G = (V, E), k)$  of INDEPENDENT SET. Create an influence graph as follows: For each vertex  $v \in V$ , add a node  $n_v$  and for each edge  $e \in E$ , add a node  $n_e$ . Let  $N_V := \{n_v \mid v \in V\}$  and  $N_E := \{n_e \mid e \in E\}$ . Add an arc  $n_v \rightarrow n_e$  with influence probability 1 for each edge  $e$  incident to vertex  $v$  in  $G$ . Set  $c := k$ ,  $b := |V| - k$ , and  $A := N_V \cup N_E$ .

Consider any solution with cost  $c$ . Note that we can assume any optimal solution to choose only nodes from  $N_V$ , since for any edge  $e = \{u, v\} \in E$  it is always better to choose either  $n_v$  or  $n_u$  instead of the node  $n_e$ . Write  $X \subseteq N_V$  for the set of effectors,  $N_I = N_V \setminus X$ , and  $I = \{v \mid n_v \in N_I\}$ . We have  $|X| \leq b$  and  $|I| = |N_I| = |V| - |X| \geq |V| - b = k = c$ . Since the cost equals  $c$ , it follows that  $|N_I| = c$  and only the nodes in  $N_I$  are left inactive. Hence, no edge  $e$  has both endpoints in  $I$ . That is,  $I$  is an independent set of size  $c = k$ . Conversely, any independent set  $I$  of  $G$  directly translates into a set of effectors  $X = \{n_v \mid v \in V \setminus I\}$  for the created influence graph.

We finish with the third statement, namely, that if  $r = 0$ , then INFLUENCE MAXIMIZATION can be solved in  $O\left(\binom{b+c}{b} \cdot (n+m)\right)$  time. To start with, let  $G'$  be the condensation of  $G$  (that is, the DAG obtained by contracting each strongly connected component (SCC) of  $G$  into one node). Note that since  $r = 0$ , we can assume that any minimal solution selects at most one node from each SCC in  $G$ . Moreover, it does not matter which node of an SCC is selected since they all lead to the same activations. Hence, in the following, we solve INFLUENCE MAXIMIZATION on the condensation  $G'$ , where selecting a node means to select an arbitrary node in the corresponding SCC in  $G$ .

Let  $R$  denote the set of nodes of  $G'$  with in-degree zero. Note that any node in  $R$  not chosen as an effector yields a cost of at least 1 in  $G$ , since the nodes in its corresponding SCC cannot be activated by in-neighbors. Hence, we can assume that  $|R| \leq b + c$ , because otherwise the instance is a “no”-instance. Moreover, we can assume that all effectors are chosen from  $R$ . Indeed, consider any solution selecting a node  $u \notin R$  as effector. Then,  $u$  has at least one in-neighbor  $v$  and selecting  $v$  instead yields the same number of effectors, while the cost can only be reduced (since at least as many nodes are activated). Since the graph  $G'$  is a DAG, repeating this process yields a solution with smaller cost having only effectors in  $R$ . Hence, it is sufficient to enumerate all possible choices of size- $b$  subsets of the  $b + c$  nodes in  $R$ , and check in polynomial time whether the chosen set of effectors in  $G$  yields a cost of at most  $c$ .  $\square$

#### 5.4 Results in Contradiction with Lappas et al. [15].

The following two claims of Lappas et al. [15] are contradicted by the results presented in our work.

According to Lappas et al. [15, Lemma 1], in the INFLUENCE MAXIMIZATION case with cost value  $c = 0$ , EFFECTORS is NP-complete. The reduction is incorrect: it uses a target node  $\ell$  which influences all other vertices with probability 1 (in at most two steps). It suffices to select  $\ell$  as an effector in order to activate all vertices, so such instances always have a trivial solution ( $X = \{\ell\}$ ),

and the reduction collapses. On the contrary, we prove in our Lemma 1 that all instances with  $c = 0$  can be solved in linear time.

According to the discussion of Lappas et al. [15] following their Corollary 1, there exists a polynomial-time algorithm for EFFECTORS with deterministic instances (meaning  $r = 0$ ). Their model coincides with our model in the case of INFLUENCE MAXIMIZATION. However, the given algorithm is flawed: it does not consider the influence *between* different strongly connected components. Indeed, as we prove in Theorem 6, finding effectors under the deterministic model is NP-hard, even in the case of INFLUENCE MAXIMIZATION.

## 6 Conclusion

Inspired by work of Lappas et al. [15], we contributed a fine-grained computational complexity analysis of a “non-monotone version” of finding effectors in networks. Indeed, we argued why we believe this to be at least as natural as the more restricted “monotone model” due to Lappas et al. [15]. A particular case for this is that we may find more robust solutions, that is, solutions that are more resilient against noise. The central point is that, other than Lappas et al. [15], we allow non-target nodes to be effectors as well, motivated by the assumption that knowledge about the state of a node may get lost from time to time (see Section 3 for further discussion). Altogether, we observed that both models suffer from computational hardness even in very restricted settings. For the case of unlimited budget, we believe that both models coincide with respect to solvability and hence with respect to a fine-grained computational complexity classification.

Our work is of purely theoretical and classification nature. One message for practical solution approaches we can provide is that it may help to get rid of some probabilistic arcs by rounding them up to 1 (making them deterministic) or rounding them down to 0 (deleting the arcs)—this could be interpreted as some form of approximate computation of effectors. Network structure restrictions seem to be less promising since our hardness results even hold for directed acyclic graphs. Still, there is hope for finding further islands of tractability, for instance by ignoring budget constraints and restricting the degree of randomness.

We leave several challenges for future research. First, it remains to prove or disprove Conjecture 1. Moreover, while we considered most of the parameterizations for most of the variants of the EFFECTORS problem, we have left some work for future research, specifically the parameterized complexity of EFFECTORS where there is infinite budget and arbitrarily-many probabilistic arcs (see the corresponding open question in Table 1). A further, more general direction would be to consider other diffusion models and other cost functions. For example, it is also natural to maximize the probability that precisely the current activation state is achieved when selecting the effectors to be initially active. Moreover, it seems as if the current diffusion model and its somewhat complicated probabilistic nature is one of the main reasons for the intractabil-

ity of our problem. It would be interesting to consider other diffusion models, possibly simpler ones, and see whether it is possible to push the tractability results to apply for more cases. Specifically, it would be interesting to extend our results concerning the parameter “degree of randomness” to such models.

**Acknowledgements** We are grateful to two anonymous reviewers of *Theory of Computing Systems* whose careful and constructive feedback helped to significantly improve the presentation of the paper.

## References

1. R. K. Ahuja, T. L. Magnanti, and J. B. Orlin. *Network Flows: Theory, Algorithms, and Applications*. Prentice Hall, 1993.
2. S. Arora and B. Barak. *Computational Complexity: A Modern Approach*. Cambridge University Press, 2009.
3. G. Askalidis, R. A. Berry, and V. G. Subramanian. Explaining snapshots of network diffusions: Structural and hardness results. In *Proceedings of the 20th International Conference on Computing and Combinatorics*, volume 8591 of *LNCS*, pages 616–625. Springer, 2014.
4. C. Bazgan, M. Chopin, A. Nichterlein, and F. Sikora. Parameterized in-approximability of target set selection and generalizations. *Computability*, 3(2):135–145, 2014.
5. C. Bazgan, M. Chopin, A. Nichterlein, and F. Sikora. Parameterized approximability of maximizing the spread of influence in networks. *Journal of Discrete Algorithms*, 27:54–65, 2014.
6. O. Ben-Zwi, D. Hermelin, D. Lokshtanov, and I. Newman. Treewidth governs the complexity of target set selection. *Discrete Optimization*, 8(1):87–96, 2011.
7. S. Bharathi, D. Kempe, and M. Salek. Competitive influence maximization in social networks. In *Proceedings of the Third International Workshop on Internet and Network Economics*, volume 4858 of *LNCS*, pages 306–311. Springer, 2007.
8. M. Chopin, A. Nichterlein, R. Niedermeier, and M. Weller. Constant thresholds can make target set selection tractable. *Theory of Computing Systems*, 55(1):61–83, 2014.
9. M. Cygan, F. V. Fomin, Ł. Kowalik, D. Lokshtanov, D. Marx, M. Pilipczuk, M. Pilipczuk, and S. Saurabh. *Parameterized Algorithms*. Springer, 2015.
10. P. Domingos and M. Richardson. Mining the network value of customers. In *Proceedings of the Seventh ACM SIGKDD International Conference on Knowledge Discovery and Data Mining*, pages 57–66. ACM, 2001.
11. R. G. Downey and M. R. Fellows. *Fundamentals of Parameterized Complexity*. Springer, 2013.

12. M. R. Fellows, D. Hermelin, F. Rosamond, and S. Vialette. On the parameterized complexity of multiple-interval graph problems. *Theoretical Computer Science*, 410(1):53–61, 2009.
13. J. Flum and M. Grohe. *Parameterized Complexity Theory*. Springer, 2006.
14. D. Kempe, J. M. Kleinberg, and É. Tardos. Maximizing the spread of influence through a social network. *Theory of Computing*, 11:105–147, 2015.
15. T. Lappas, E. Terzi, D. Gunopulos, and H. Mannila. Finding effectors in social networks. In *Proceedings of the 16th ACM SIGKDD International Conference on Knowledge Discovery and Data Mining*, pages 1059–1068. ACM, 2010.
16. A. Nichterlein, R. Niedermeier, J. Uhlmann, and M. Weller. On tractable cases of target set selection. *Social Network Analysis and Mining*, 3(2): 233–256, 2013.
17. R. Niedermeier. *Invitation to Fixed-Parameter Algorithms*. Oxford University Press, 2006.
18. L. G. Valiant. The complexity of enumeration and reliability problems. *SIAM Journal on Computing*, 8(3):410–421, 1979.
19. C. Wang, W. Chen, and Y. Wang. Scalable influence maximization for independent cascade model in large-scale social networks. *Data Mining and Knowledge Discovery*, 25(3):545–576, 2012.