



**HAL**  
open science

## Model-based development of modular complex systems for accomplishing system integration for industry 4.0

Kunal Suri, Arnaud Cuccuru, Juan Cadavid, Sébastien Gérard, Walid Gaaloul, Samir Tata

### ► To cite this version:

Kunal Suri, Arnaud Cuccuru, Juan Cadavid, Sébastien Gérard, Walid Gaaloul, et al.. Model-based development of modular complex systems for accomplishing system integration for industry 4.0. 5th International Conference on Model-Driven Engineering and Software Development (MODELSWARD), Institute for Systems and Technologies of Information, Control and Communication (INSTICC), Feb 2017, Porto, Portugal. pp.487-495, 10.5220/0006210504870495 . hal-01474906

**HAL Id: hal-01474906**

**<https://hal.science/hal-01474906v1>**

Submitted on 23 Feb 2017

**HAL** is a multi-disciplinary open access archive for the deposit and dissemination of scientific research documents, whether they are published or not. The documents may come from teaching and research institutions in France or abroad, or from public or private research centers.

L'archive ouverte pluridisciplinaire **HAL**, est destinée au dépôt et à la diffusion de documents scientifiques de niveau recherche, publiés ou non, émanant des établissements d'enseignement et de recherche français ou étrangers, des laboratoires publics ou privés.

# Model-based Development of Modular Complex Systems for Accomplishing System Integration for Industry 4.0

Kunal Suri<sup>1,2</sup>, Arnaud Cuccuru<sup>1</sup>, Juan Cadavid<sup>1</sup>, Sebastien Gerard<sup>1</sup>, Walid Gaaloul<sup>2</sup> and Samir Tata<sup>3,2</sup>

<sup>1</sup>CEA, LIST, Laboratory for Model-driven Engineering for Embedded Systems, P.C. 174, 91191, Gif-sur-Yvette, France

<sup>2</sup>TelecomSudParis, UMR 5157 Samovar, Université Paris-Saclay, Evry, France

<sup>3</sup>IBM Research, San Jose, CA, U.S.A.

**Keywords:** Industry 4.0, Smart Factory, Model-driven Engineering, MDE, Model Execution, UML, Modularity, Integration, CPS, Lego EV3 Robot.

**Abstract:** Industry 4.0 provides a framework for integration of cyber-physical systems (CPS), internet of things (IoT), internet of services (IoS) and internet of data (IoD) with the manufacturing domain so as to make it smart, flexible and adaptable to the dynamic market changes and the customer requirements. It will enable companies to form a connected "smart manufacturing" ecosystem having interconnections between the suppliers, manufacturers, distributors and even the products in order to provide better services to the end customer. However, due to the presence of heterogeneous systems that might not adhere to the industrial standards, there is a gap in achieving this vision of an interconnected ecosystem. In this paper, we focus on providing a solution for the modularity and interoperability issues related to the Industry 4.0 from a systems integration viewpoint. We propose a model-based approach for modular complex systems development by separating (1) the behavior model and (2) the implementation logic (execution) of the system. Moreover, we use unified modeling language (UML) based modeling techniques to model system behavior and connect the behavior models to the application programming interface (API) of the CPS. Thus, instead of generating source code for the CPS using models, we directly execute the CPS in the physical world via model execution. The model execution is supported by the standard execution semantics of UML. Using our approach, multiple heterogeneous systems can be modeled and integrated together to create a "plug and play" ecosystem needed for achieving the vision of Industry 4.0.

## 1 INTRODUCTION

In recent years, the dawn of the fourth Industrial revolution (Industry 4.0) has created a great enthusiasm among companies and researchers by providing them an opportunity to pave the path towards the vision of the "smart factory". This interest in Industry 4.0 is due to the fact that, it is for the first time in the history of an industrial revolution that, it has been predicted a-priori, rather than being observed ex-post (Hermann et al., 2016). Industry 4.0 provides a framework for integration of CPS, IoT, IoS, IoD with the manufacturing domain to make it smart, flexible and adaptable to the dynamic market changes and the customer requirements. It is envisioned to have a great economic impact for companies in many ways, such as, enabling factories to be reconfigured over a weekend instead of taking a month, creating customized products for the end users, reducing wastage of resources

such as energy. It will provide the possibility of creating new business opportunities by making efficient use of human resources and having end to end connected supply chain management. Additionally, Industry 4.0 is based on six design principles which are, interoperability, virtualization, decentralization, real-time capability, service orientation and modularity (Hermann et al., 2016). Moreover, it is this very need for creation of new business opportunities that requires the factories to be flexible (for e.g. easy re-configuration) in context of Industry 4.0.

Furthermore, the system integration can be seen from two viewpoints, as shown in figure 1, (1) horizontal integration and (2) vertical integration. The horizontal integration (or inter-company integration) will be the base for a strong collaboration between various companies and their stakeholders. These companies will interact with each other and create a seamless inter-connected ecosystem. Moreover, for

these systems to be interoperable they need to be developed in a platform-independent manner based on industrial standards. This will enable them to exchange data or information and avoid vendor lock-in issues. In the same way, the vertical integration (or intra-company integration) shall also be based on standards.

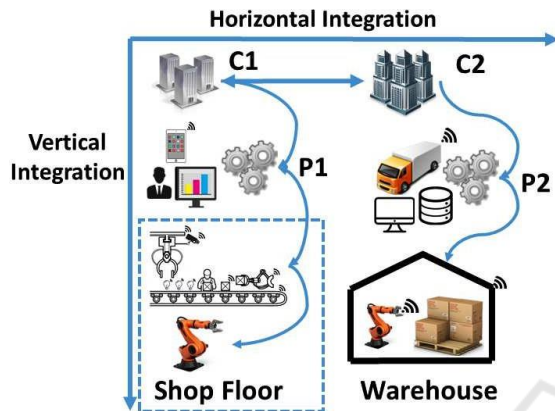

Figure 1: Vertical and Horizontal Integration.

In this paper, we focus on the "vertical integration" of system using the model-driven engineering (MDE) approach. In vertical integration the models (for e.g. a production process model) that are modeled by a certain stakeholder (for e.g. production analysts) will have a traceable link with other fine-grained models (for e.g. a robots behavior models) modeled by another stakeholder (for e.g. a systems engineer). This traceability will help in achieving a better management of information between various layers within an organization along with a better impact analysis of the changes made in different layers. Moreover, as these models are based on standards, the same models can be used for the purpose of simulation and also for execution of the systems that they depict. For instance, the execution of a industrial robot on a shop floor will benefit from the model-based execution approach wherein, there is a separation between its behavior model (control flow) and its actual implementation logic. The behavior can be modeled using industrial standard such as, the unified modeling language (UML) activity diagram that will describe "how to achieve a certain task". These models can be used to perform simulations for depicting how the system works. The same models will then be executed based on the standardized semantics of UML model execution. As, the semantics of UML model execution provides a standard mechanism to connect and communicate with external software and tools, it will allow the models to communicate and execute the robots in the physical world via standard APIs of the

robots firmware .

In contrast to the state of the art of model-driven approaches in robotics, we view our approach based on model execution as an "on-line" execution. In our approach the CPS executes live in sync with the model being executed, where as, in most of the other model-based approaches the models are used to create source code for the CPS which is then installed on it making it a "of-line" execution. In other words, rather than creating source code from our models, we directly execute the CPS in the physical world through model execution. This provides a good mechanism for tackling co-simulation problem for CPS (Rahman and Mizukawa, 2013)

Moreover, for simplicity reasons, we consider a simple robot as one of the concrete depiction of a CPS in context of the Industry 4.0. We validated our approach by using a Lego EV3 robot (EV3, 2013) installed with an open-source java based firmware called LeJOS (Lejos, 2015). The model design and model execution is performed using Papyrus framework (Papyrus, 2016) .

This article is structured as follows. Section 2 describes the context of this work in relation to complex system development and model-driven engineering (MDE) for Industry 4.0. Section 3 provides some insight on the related work. Section 4 describes our approach followed with experimentation in Section 5. This is followed by discussion in Section 6. We conclude our paper in Section 7.

## 2 CONTEXT

### 2.1 Industry 4.0 and Smart Factory

One of the goals for the Industry 4.0 vision is to create manufacturing ecosystems that are smart, flexible and adaptable to dynamic market changes and customer requirements. Such smart factories will understand the state of a production process and will react accordingly with minimal human intervention. Moreover, in case of system fault if the cyber-physical system (CPS) or the cyber-physical production systems (CPPS) needs human support, the system itself will assist the humans with appropriate contextual information to avoid cognitive overload on them (Wieland et al., 2010).

Recently, various research in context of Industry 4.0 is being focused towards understanding how MDE can benefit the Industry 4.0 vision as a key technology enabler. In their recent work, the authors (Cadauid et al., 2015) provide arguments about the importance of MDE for smart manufacturing and how

MDE with its underlying concepts such as, domain specific modelling languages, modelling abstractions based on view-points, model-based formal analysis and automated model transformations would help to transform the vision of Industry 4.0 into a reality.

## 2.2 Model-Driven Engineering for Complex Systems

A complex system, such as a cyber-physical system (CPS), an industrial robot or a service robot, consists of a large number of component such as, actuators, sensors, auxiliary tools along with the firmware that are all seamlessly integrated together and need to work as a single entity. These complex systems would also interact with other complex systems to perform certain tasks. Thus, it is very important to design these complex systems keeping the principle of modularity in mind so as to allow ease of integration between various systems.

In addition to above, a complex system also consists of different parts relating to different kinds of engineering disciplines such as, mechanical, electrical, software. Thus, these systems are required to be verified and tested both (1) at the component level and (2) at a system level. Therefore, MDE can help in reducing the inherent complexity of these systems by providing standard modeling languages, and providing tools and frameworks that supports various design principles. For example, using the principles of "separation of concerns" we can abstract various aspects of a system and can view only the things that are important to us, thus reducing complexity.

## 3 RELATED WORK

In recent years, a number of research contributions in MDE have been looking at the applications of MDE in design and execution of complex systems such as, industrial robots. On the same lines, the authors (Steck et al., 2011) put forward the importance of moving from code-driven to model-driven engineering for industrial-strength service robotic systems. Their work is focused on the entire life-cycle of robot development wherein they provide a model-centric view on the whole (robotic) system covering both the design time and the run time of the robot. The model-driven development will support the decision making process of a robot during its run-time based on parameters, properties and resource information that were modelled at design-time. This will enable it to handle a large number of situations. Plus, modeling would help to reduce the complexity for differ-

ent stakeholders based on the principle of "separation of concerns". Similarly, in the work done by (Rahman and Mizukawa, 2013), the authors describe the difficulty faced in achieving a holistic system-level verification along with the problem of fulfilling the requirements of different stakeholders using only descriptive systems models (SysML). Thus, they proposed to combine the descriptive and simulation models by providing a collaborative design framework which brings SysML, Simulink, and Simscape profiles within the domain of robotic modeling.

Likewise, (Inglés-Romero et al., 2013) express the need to create a domain specific language (DSL) for expressing variability for the non-functional properties for a robotic system. They argue that in context of a service robot there will always be unforeseen situations that are needed to be tackled at run-time but, may have not been modelled at design time. They used the variability modelling language (VML) at design time to resolve such problems. The authors (Gherardi and Brugali, 2014), provide a development process containing guidelines to exploit existing best practices and reference architectures for robotic software. Similarly, in their work (Romero-Garcés et al., 2013) present four DSLs wherein each DSL has a specific perspective for defining a robot component and are all based on model-driven techniques. They compare and analyse the effort based on lines of code for robot development before and after making use of these DSLs. They argue that these DSLs, reduce the workload of the developers depending on what "concerns" they need to focus during the robots life-cycle. They also describe the improvements in flexibility, scalability and maintenance for RoboComp framework using MDE along with the benefit from model-to-model, model-to-text transformations approaches and to generate source code automatically. Other authors, such as, (Schlegel et al., 2015), have described steps need to create a software business ecosystem in robotics using model-driven software development and model-driven software systems integration

Furthermore, in their work (Harrand et al., 2016), the authors reinforce the benefits of model-based systems engineering (MBSE) for increasing productivity by automated code generation from models. They provide an open-source project called "ThingML" which includes a modelling language and tool designed for supporting code generation using highly customizable multi-platform code generator targeting heterogeneous platforms. Their work may benefit the heterogeneous systems environment in context of the Industry 4.0. Other researchers like (Kovalenko et al., 2015) explored the AutomationML format which is an emerging data exchange standard for supporting

the Industry 4.0 vision. This standards can be represented via two modelling approaches, MDE and Semantic Web. They pointed out the differences in these approaches and provide the applications of these approached for improving the production processes in manufacturing domain. In context of real-time systems, the authors (Perseil et al., 2011), presented a modeling and execution framework through which it will be possible to analyse, design and verify complex systems. This approach would help to tackle specific concerns of the real-time and embedded systems (RTE) domain.

In particular, (Tatibouët et al., 2014) discussed the use of UML profile mechanism for designing a DSL in their work. They argued the need for having an execution semantics for UML profiles as the current profile design methodology only considers the syntactic part of the language, keeping the execution semantics description as informal. In their work, they provide a systematic approach to formalize the execution semantics of UML profiles. To realize their approach they make use of foundational UML (normative specification) which defines a precise semantics for a subset of UML.

## 4 APPROACH

In this section, we describe our approach for development and executing of a model-based modular system using open standards. This approach will enable heterogeneous systems to communicate with each other in a cohesive but loose coupled manner. For our approach, we used Unified Modeling Language (UML2.5, 2015), which is a general-purpose, developmental, modeling language in the field of software engineering. Additionally, in this work we depict a cyber-physical system (CPS) as a simple robot that will expose its functionality using standard APIs which will be called by the executing behavior models (activity model in our case).

### 4.1 Conceptual Approach

In context of Industry 4.0, we have already established the need to develop systems based on industrial standards keeping the principle of modularity in mind. This will help to achieve interoperability and a plug and play kind of environment as envisioned for Industry 4.0. In our approach, we separated the concerns of developing and executing the robot. The robot executes based on instructions (events) it receives from the control flow layer. This, separation helps to achieve a loose coupled system. In particu-

lar, this approach has been developed keeping industrial robots in mind which perform standard repetitive tasks. But, these robots need to be flexible (for e.g. easy to reconfigure) so as to perform new tasks as and when needed. Also, these robots should be able to communicate with other similar or non-similar robots present in the ecosystem of a smart factory.

In the figure 2, we show the two separate layers i.e. the model-based behavior layer (control flow) and robots implementation layer. In our approach, the software layer on the robot will be kept as minimal as possible. The execution of the robot is done using API calls through an executing model (on-line execution) rather than deploying the source code on the complex system (of-line execution). This approach will allow creation of complex systems having sensors and actuators with low computational power and low energy usage. In such a setting, the models while executing would send control events to the software (middleware or firmware) layer of the robots and the robots should respond to them with status event.

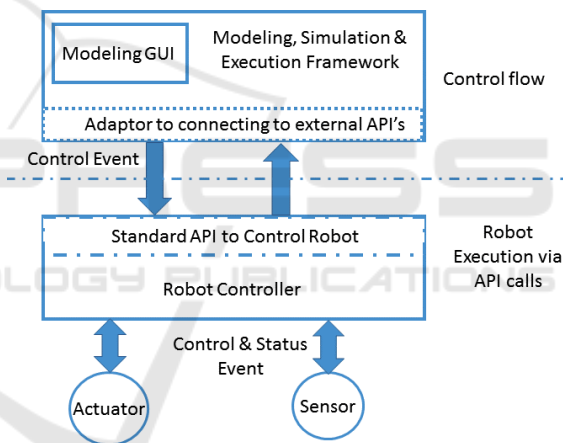

Figure 2: Conceptual Approach for Modular Complex System Development.

### 4.2 Refinement of the Approach

To concretize the above conceptual approach, we make use of the Papyrus framework for designing the models and execution of the EV3 robot. Papyrus framework is a part of the Eclipse foundation and PolarSys (PolarSys, 2016). It provides a graphical editing tool for UML as defined by Object Management Group (OMG, 2016). Additionally, it provides tool support for executable UML modeling through the Moka execution engine (Moka, 2016). Papyrus provides a fully customizable environment to define custom graphical, textual or tabular notation. Being based on UML profile it allows reuse of standard languages or creation of new modeling language. Fur-



thermore, the execution and debugging of models is handled by Moka which itself relies on an implementation of the OMG standards called "Semantics Of A Foundational Subset For Executable UML Models" (FUML, 2013) and "Precise Semantics of UML Composite Structures" (PSCS, 2015). These specifications formalize the execution semantics of a UML subset. In Papyrus, the editing part relies on the OMG standard called "Action Language For Foundational UML" (ALF, 2013), with an editor and compiler for that language.

Most importantly, Papyrus framework provides the possibility to connect with external softwares and tools which is essential for our model-based development approach. In particular, a robot is composed of different components that need to work together seamlessly. Many of these components belong to different kinds of engineering disciplines such as, mechanical, electrical, computers and will be built using various software's having their own simulation environments. Normally, each component can be easily modeled and simulated for verifying its correctness at a component level but there are not many standard frameworks available that provide a co-simulation approach to assess the correctness of the overall system model. Thus, a FUML based simulation tool that connects to different external tools would be very useful for doing a system level co-simulation in context of CPS in general.

Moreover, FUML 1.1 (FUML, 2013) provides "opaque behaviors" which shall be hooked to a concrete "OpaqueBehaviorExecution" implementing its own semantics and these implementations can be used to communicate with external tools (Guermazi et al., 2015). In context of Papyrus Moka, during a model execution, when a call is made to an opaque behavior from a model element, it drives the execution flow to the logic that enables the connection to a specific tool or library. Once the specific library (tool) executes the execution flow comes back to the running model.

The figure 3 depicts the concretization of the conceptual approach initially described in the figure 2. It is visible from the figure 3 that the model-based control flow layered is based on the Papyrus framework, which provides both (1) the modeling GUI and (2) the model execution and simulation engine known as Moka. We designed a UML activity diagram in papyrus modeler and then connected the model elements to the opaque behaviors designed as plugins. The opaque behavior follow the FUML semantics and enable the connection to the external tools (third party). In the implementation part of the opaque behavior, we created adaptors to connect to LeJOS firmware (Lejos, 2015) which have been installed on Lego EV3

(EV3, 2013). LeJOS is an open-source java based operating system (OS) for a Lego EV3 controller. There are also other OS such as EV3Dev<sup>1</sup> but we chose LeJOS as it was java based and provided remote APIs to connect and control EV3.

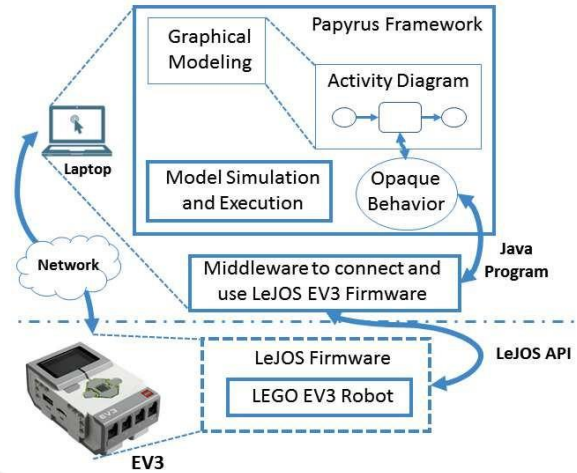

Figure 3: Concrete Approach using Papyrus Framework and Lego EV3 Robot.

## 5 EXPERIMENTATION

In this section, we implement our approach described in section 4.2 by creating an experiment with a Lego EV3 robot. A Lego EV3 might be a simplified example of a CPS, but it useful in showing our approach successfully and we can argue that the same approach can be applied to more complex robots or multiple heterogeneous robots. During our experimentation, the models, the java based adaptors for LeJOS and the model execution are all done using Eclipse Papyrus framework.

### 5.1 Implementation: Lego EV3 Robot

#### 5.1.1 Background

Firstly, we selected a Lego EV3 robot to implement our approach for depicting a model-based execution of a system as, (1) a Lego EV3 robot matches our need to depict a system that can execute actuators and sensors. (2) Lego EV3 is plug and play, not very expensive and can be easily build to depict different scenarios. (3) It has a strong community of users and developers along with the availability of various open-source software. Additionally, it is important to mention that Lego provides its own proprietary software

<sup>1</sup><http://www.ev3dev.org/>

tool called "Lego Mindstorms" based on LabVIEW<sup>2</sup> to build executable code for EV3 robot in a model-driven manner. Moreover, Lego claims that the process of using GUI based robot modeling technique for modeling robot behaviour on their proprietary tool is quite easy and intuitive. It is easy enough such that a 10 year old can use it to build their own robot (LEGO-Education, 2016). This reconfirms our point that MDE is one of the good techniques available for developing complex systems such as robots. In contrast to the benefits, there are certain shortcomings of the Lego Mindstorm software due to which we can't use it as such. These shortcomings are, (1) the tool is proprietary and not open-source thus, we cannot make changes to the APIs (2) it does not follow any open standards (3) to the best of our knowledge, the Lego Mindstorm software does not provide any kind of standard API to control EV3 from external tool (such as Papyrus framework) (4) the tool is used to deploy the code directly on the EV3 (offline mode) and doesn't provide any mechanism to allow execution of EV3 from an executing model.

To tackle the above mentioned problem with Lego proprietary software, we make use of an open-source java based firmware for EV3 called LeJOS. We use this tool for following reasons, (1) it provide connection to EV3 via its remote API using IP address (depicting the ideas of an IoT), (2) each actuator and sensor can be controlled independently using the port id and IP address.

For our experimentation, we created a Lego robotic car using two large motors (actuator) as shown in the figure 4.

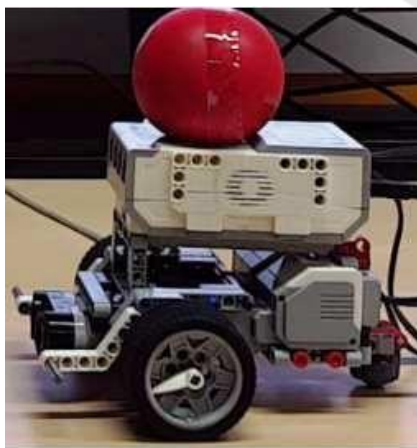

Figure 4: Lego EV3 Robotic Car.

<sup>2</sup><http://www.ni.com/labview/>

### 5.1.2 Setup

The figure 5 shows a behavior model (activity model) having a behavior called "Move Lego EV3 Motor". This activity has four input values. The input values are used to provide the IP address of the robot, the port of the actuator, the speed of the motor and the degree of rotation for the robot (number of revolution).

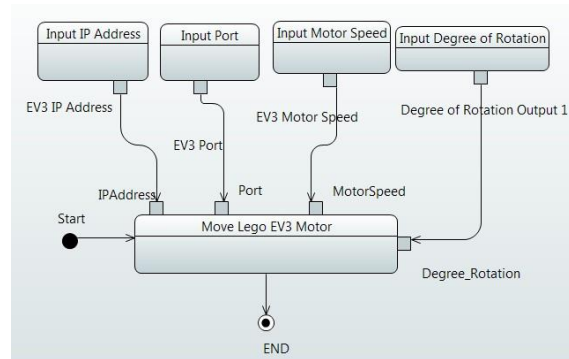

Figure 5: Model showing the UML Activity Model to Move the Car.

In order to execute the robotic Lego car, i.e. to make it move in the physical world, we execute the behaviour model by making use of the FUMML based Moka engine. This is achieved by creating an opaque behavior called "RotateEV3MotorExecution". This behavior extends "OpaqueBehaviorExecution" and connects to the remote APIs of the LeJOS to control and move the EV3 robot car. These opaque behaviors are reusable and can be used for any number of separate models by providing different values for input variables. In our case, the input values needed to move the robot are, the IP address, port, motor speed and the degree of rotation.

When the model is executed, it calls the above mentioned opaque behavior and then passes the control to the adaptor created for the robot. The java based adaptor in-return calls the LeJOS APIs and provide the incoming input values of the model to the firmware. The LeJOS firmware on the EV3 robot gets these values and executes the command to move the actuator. As a note, Lego EV3 also has sensors for data collection such as, color sensor, ultrasound sensor but to keep our experiment simple we do not make use any sensor data in this current work.

### 5.1.3 Model-based Execution

The figure 6 shows the execution of the UML behavior model (activity model) using FUMML based Papyrus Moka engine. In the Papyrus framework, when a model element has been executed (completed) the

color of the element changes to green. While the red color indicates that a model element is currently being executed. While executing the model, Moka will pass the input values to the underlying opaque behavior and the robot will start moving as explained in the above section. In case, of any kind of problem with the underlying robot such as, issues with connection between robot and computer, the same model can still be executed like a normal simulation without the actual physical executing of the underlying robot. The error handling will displaying the error message to the developers for rectifying the problems. For e.g., one of such common error message is "connection refused to host: 10.0.1.1", which occurs when there is a problem in the wired connection between the robot and the laptop.

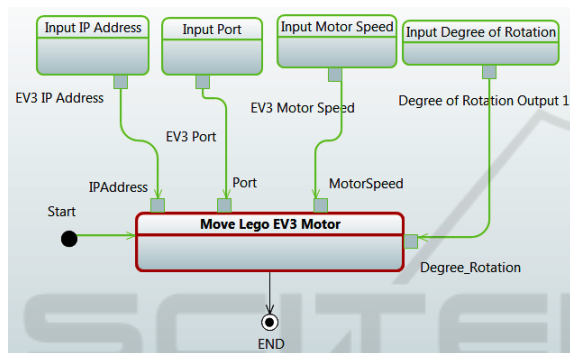

Figure 6: FUMML based Model Execution.

## 5.2 Evaluation

In this section, we evaluate some of the use cases for EV3 robot using our approach as follows:

### (1) Changes to the Behavior Model

**Description:** In case of a new system requirement, how beneficial is the model-based execution approach?

**Experience:** Firstly, this approach provides loose coupling between the control flow and execution code. Secondly, as the execution of the robot is based on execution of the models via API calls, we can argue that the changes to the system can be tackled easily. For e.g., initially, we created the "EV3 car movement" process to move the EV3 car only in the forward direction. This process consisted of a single activity "Go Front". But, when there was a need to move the EV3 in backward direction, we created a new task called "Go Back" and used the same opaque behavior created before with different input values. In our experience, the addition of the new task and the update to the model was fast and simple, like a drag and drop of the activity task and then addition of

the opaque behavior to it with different input values. Thus, using our approach a behavior model can be updated quickly along with the reuse of existing opaque behavior(s), creating a flexible and easy to reconfigure complex systems environment.

### (2) Interchanging Similar EV3 Robots or Actuators

**Description:** In case of a need to change or update a EV3 controller or an actuator, how beneficial is this approach to manage such changes?

**Experience:** Due to the separation between the model execution (control flow) and the robot execution using API calls, it is easy to manage such a need. To change a problematic EV3 with a new EV3, only the IP address of the new EV3 needs to be updated in the activity model. Similarly, to change or update the EV3 actuator, only the port id needs to be updated in the behaviour model. Thus, we can argue that using model-based execution it is possible to create a plug-and-play environment.

Likewise, as this approach uses standard API calls of the robot via IP address, we can argue that this approach can help to realize an IoT environment.

## 6 DISCUSSIONS

The following points are noteworthy for model-based development for complex systems in context of Industry 4.0:

(1) Model-based development of CPS provides easy system integration due to the use of standard tool and languages (UML). It helps in creation of an interoperable and "plug and play" type ecosystem. Moreover, MDE provides need based abstraction of a system to various stake holders for different concerns. It also provide traceability between the various viewpoints leading to a better management. For example, exchange of information between strategy level (management) and business process analysts view in context of Industry 4.0.

(2) Model-based execution of CPS using standard execution semantics such as FUMML provides a possibility to connect to different software's and external tool and perform co-simulation using the same models.

(3) "Virtual factory" which is a "digital replica" of the physical factory is an important feature of Industry 4.0. The model-based execution techniques will help to create and use common model that can be used (A) in the virtual factory to do simulations and (B) the same models will be updated or enriched with data coming from the virtual factory to do an optimized ex-



ecution of the real machines in the physical world, i.e. a shop floor. Thus, knowledge gained via simulations performed in the virtual factories will be transferred to the physical factories for saving real materials and resources in the physical world.

(4) Various software and tool providers involved in Industry 4.0 will continue to build their solutions based on industry standards. The use of standards would help to resolve the issues related to interoperability between different tools. Moreover, instead of creating dedicated middlewares, the model-based approach for co-simulation can help to integrate and exchange data between the various systems.

(5) Model-based CPS execution benefits from concepts such as, "separation of concerns" that will provide abstraction to various layer of the system (viewpoints) along with concepts of loose coupling. Thus, in case of replacement of the old system with a new one, there will be no need to redesign the behavior models from scratch. The same models can be reused by creation new connection or adaptors to the external tool. However, this seamless change would only be possible provided the new system provides all the functionality of the old system.

(6) Furthermore, model-based execution enhances understandability of the exact state of execution of a machine. MBSE provides another advantages, such as, a strong community and standards based open-source tools. This help to achieve "digital continuity" wherein, a system model created in one standard is transformed into another standards (model-to-model or model-to-text). In context of Industry 4.0, this is beneficial as, an activity model can be transformed into a business process modeling and notation (BPMN) model and can be executed on a manufacturing execution system (MES) which executes machines on industrial shop floor.

## 6.1 Limitations

Our work is based on the assumption that the CPS will expose standard API for communication. Moreover, we map or glue the functionality of the CPS via APIs to the opaque behavior(s) created in the modeling framework (based on FUMML semantics). However, a system model cannot execute a functionality which is not provided by the API of the CPS.

Initially, this work was done keeping industrial robots in the mind that perform standard repetitive tasks. This approach was not built in context of autonomous robots. Furthermore, at this stage we did not create a domain specific language (DSL) for our approach, but as this approach is based on UML standards, it is possible to extend this work for creating a

DSL without much effort. Most importantly, the implementation of this approach is tightly coupled to the modeling and execution framework or tool, thus the model execution would be effected by the limitation and performance issues of the tools.

## 7 CONCLUSION AND FUTURE WORK

Industry 4.0 presents great opportunities for the manufacturing sector, but it also lays great challenges on the development of complex industrial systems that will realize the vision of the connected, flexible and smart industry. In this paper, we discussed several of those challenges, namely, horizontal and vertical integration, interoperability and modularity. These challenges can be tackled through the use of model-driven engineering, mainly, for the description or design and execution of the industrial cyber-physical processes and robotic systems.

The main contribution of this paper is a conceptual model-based approach for modular complex system development, which can be applied to industrial cyber-physical systems. This approach treats the model as the first-class citizen of system development, since the model is used for (1) modeling and simulation (the "digital world") and (2) actual execution of industrial processes and robots (the "real world"). The model thus becomes the pivot for both horizontal and vertical integration. The approach was validated with an implementation based on Lego EV3 robot and the Papyrus modeling environment with Moka as model execution engine. The outcome is an overall approach where the actual industrial automation systems are piloted from abstract models, while keeping interoperability intact thanks to the use of a standard API to communicate with the physical systems and its components.

In the future, we plan to extend this work and perform co-simulation with heterogeneous robots such as, "NAO" the humanoid robot. We also plan to experiment and refine the approach with industrial robots such as, Kuka. Plus, we plan to explore the working of this approach in a service-oriented model-driven way.

## REFERENCES

- ALF (2013). Action Language For Foundational UML (ALF), Version 1.0.1. <http://www.omg.org/spec/ALF/1.0.1/PDF>.

- Cadavid, J., Alférez, M., Gérard, S., and Tessier, P. (2015). Conceiving the model-driven smart factory. In *Proceedings of the 2015 International Conference on Software and System Process*, pages 72–76. ACM.
- EV3 (2013). LEGO Mindstorms. <https://www.lego.com/en-us/mindstorms>.
- FUML (2013). Semantics Of A Foundational Subset For Executable UML Models (FUML), Version 1.1. <http://www.omg.org/spec/FUML/1.1/PDF>.
- Gherardi, L. and Brugali, D. (2014). Modeling and reusing robotic software architectures: the hyperflex toolchain. In *2014 IEEE International Conference on Robotics and Automation (ICRA)*, pages 6414–6420. IEEE.
- Guerhazi, S., Tatibouet, J., Cuccuru, A., Seidewitz, E., Dhoubi, S., and Gérard, S. (2015). Executable modeling with fuml and alf in papyrus: Tooling and experiments. In *Proceedings of the 1st International Workshop on Executable Modeling co-located with ACM/IEEE 18th International Conference on Model Driven Engineering Languages and Systems (MODELS 2015), Ottawa, Canada, September 27, 2015.*, pages 3–8.
- Harrand, N., Fleurey, F., Morin, B., and Husa, K. E. (2016). Thingml: a language and code generation framework for heterogeneous targets. In *Proceedings of the ACM/IEEE 19th International Conference on Model Driven Engineering Languages and Systems*, pages 125–135. ACM.
- Hermann, M., Pentek, T., and Otto, B. (2016). Design principles for industrie 4.0 scenarios. In *2016 49th Hawaii International Conference on System Sciences (HICSS)*, pages 3928–3937. IEEE.
- Inglés-Romero, J. F., Lotz, A., Chicote, C. V., and Schlegel, C. (2013). Dealing with run-time variability in service robotics: towards a dsl for non-functional properties. *arXiv preprint arXiv:1303.4296*.
- Kovalenko, O., Wimmer, M., Sabou, M., Lüder, A., Ekaputra, F. J., and Biffi, S. (2015). Modeling automationml: Semantic web technologies vs. model-driven engineering. In *2015 IEEE 20th Conference on Emerging Technologies & Factory Automation (ETFA)*, pages 1–4. IEEE.
- LEGO-Education (2016). LEGO for Education. <https://education.lego.com/en-au>.
- Lejos (2015). LEJOS - Java for LEGO Mindstorms. <http://www.lejos.org>.
- Moka (2016). Papyrus Moka. Eclipse Papyrus Framework, <http://git.eclipse.org/c/papyrus/org.eclipse.papyrus-moka.git/>.
- OMG (2016). Object Management Group (OMG). <http://www.omg.org/>.
- Papyrus (2016). Eclipse Papyrus Framework. <https://eclipse.org/papyrus/>.
- Perseil, I., Pautet, L., Rolland, J.-F., Filali, M., Delanote, D., Baelen, S. V., Joosen, W., Berbers, Y., Mallet, F., Bertrand, D., Faucou, S., Zitouni, A., Boufaïda, M., Seinturier, L., Champeau, J., Abdoul, T., Feiler, P. H., Mraidha, C., and Gérard, S. (2011). An efficient modeling and execution framework for complex systems development. In *Proceedings of the 2011 16th IEEE International Conference on Engineering of Complex Computer Systems, ICECCS '11*, pages 317–331, Washington, DC, USA. IEEE Computer Society.
- PolarSys (2016). PolarSys-Open Source Solutions for Systems Engineering and Embedded Systems. Eclipse Industry Working Group, <http://www.polarsys.org/>.
- PSCS (2015). Precise Semantics Of UML Composite Structures (PSCS), Version 1.0. <http://www.omg.org/spec/PSCS/1.0/PDF>.
- Rahman, M. A. A. and Mizukawa, M. (2013). Model-based development and simulation for robotic systems with sysml, simulink and simscape profiles. *International Journal of Advanced Robotic Systems*, 10.
- Romero-Garcés, A., Manso, L., Gutierrez, M. A., Cintas, R., and Bustos, P. (2013). Improving the lifecycle of robotics components using domain-specific languages. *arXiv preprint arXiv:1301.6022*.
- Schlegel, C., Lotz, A., Lutz, M., Stampfer, D., Inglés-Romero, J. F., and Vicente-Chicote, C. (2015). Model-driven software systems engineering in robotics: covering the complete life-cycle of a robot. *Information Technology*, 57(2):85–98.
- Steck, A., Lotz, A., and Schlegel, C. (2011). Model-driven engineering and run-time model-usage in service robotics. In *ACM SIGPLAN Notices*, volume 47, pages 73–82. ACM.
- Tatibouët, J., Cuccuru, A., Gérard, S., and Terrier, F. (2014). Towards a systematic, tool-independent methodology for defining the execution semantics of uml profiles with fuml. In *Model-Driven Engineering and Software Development (MODELSWARD), 2014 2nd International Conference on*, pages 182–192. IEEE.
- UML2.5 (2015). Unified Modeling Language (UML), Version 2.5. <http://www.omg.org/spec/UML/2.5/PDF>.
- Wieland, M., Leymann, F., Schäfer, M., Lucke, D., Constantinescu, C., and Westkämper, E. (2010). Using context-aware workflows for failure management in a smart factory. In *Proc. of the Fourth Intl. Conf. on Mobile Ubiquitous Computing, Systems, Services and Technologies*, pages 379–384.