

Thermal Management Optimization of a 5 MW Power Electronic Converter

Hugo Reynes, Jose Maneiro, Cyril Buttay,
Piotr Dworakowski

iMaps – ATW on Micropackaging and Thermal
Management

02/01/2017



ALSTOM

Nexans

EDF

Outline

- DC Distribution in Offshore Windfarms
- Converter
- Thermal behavior of SiC MOSFETs
- Economic Analysis
- Conclusions

DC Distribution in Offshore Windfarms

→ Windfarm diagram with AC collector

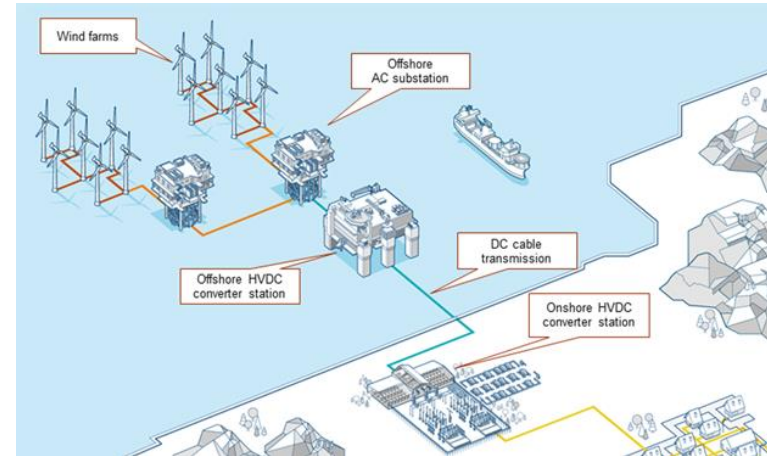
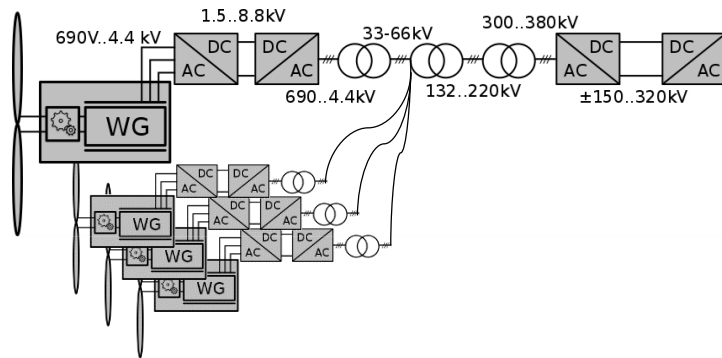

DC Solutions for offshore wind connections.
Document ABB

→ Windfarm diagram with DC collector

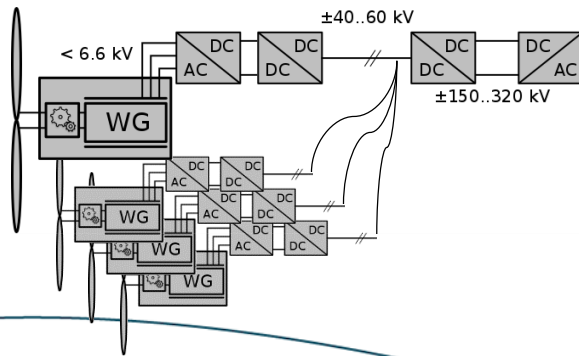

Dolwin wind farm and HVDC converter
(800 MW). Document ABB

DC Distribution in Offshore Windfarms

→ DC advantages

- No reactive power
- Flexibility for interconnexion
- 2 conductors instead of 3

→ DC grid collector setup with power electronic converters

- No low frequency transformers
- No AC Collector substation

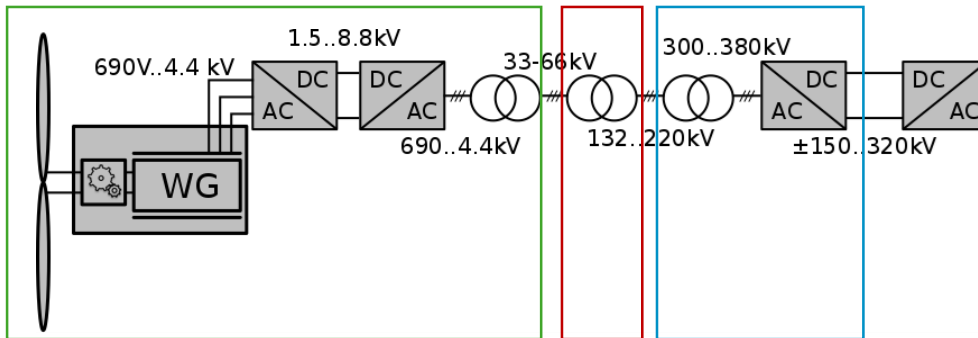

Windturbines
+AC transformer

AC Collector
platform

Rectifier
+ DC link

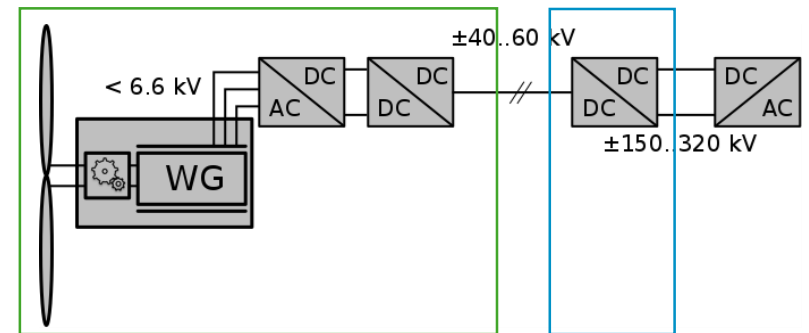

Windturbines
+DC Converter

DC collector
+ DC link

Converter

→ Diagram

- IPOS (Input Parallel, Output Series)
- 6 Medium frequency transformers

→ Overview

- 12 inverters (60cmx60cmx20cm)
- 6 power modules per inverter (72 total)
- Water Cooling

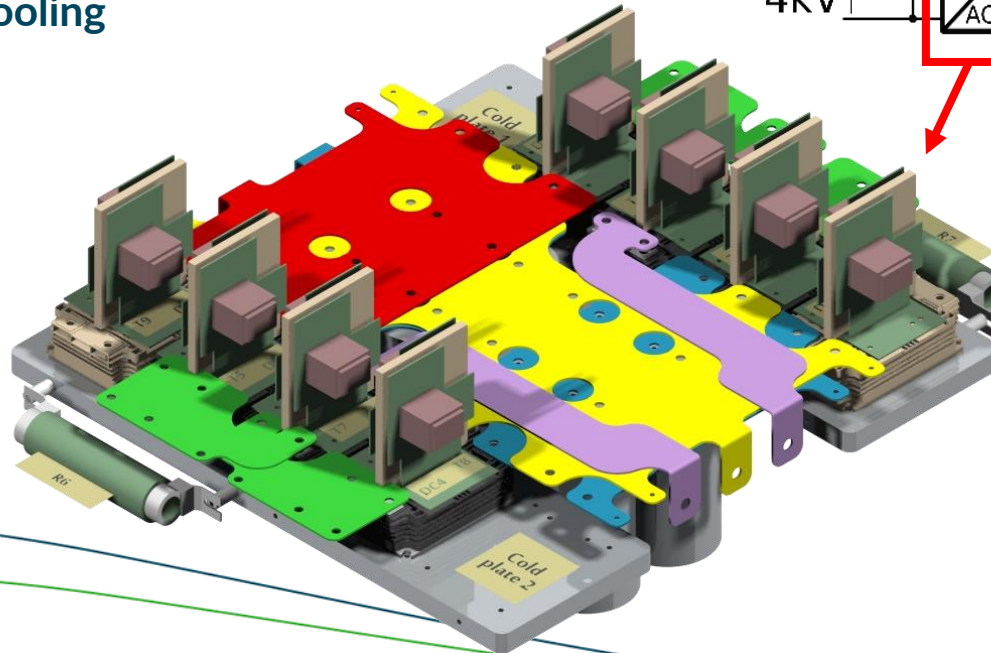
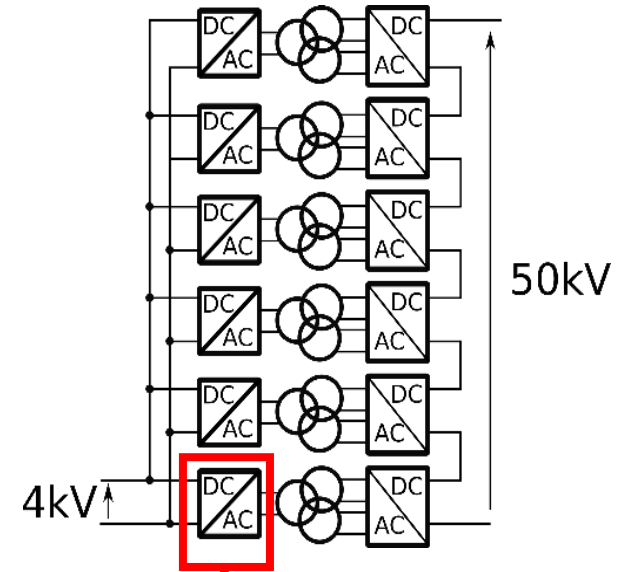

Converter

→ Power Module

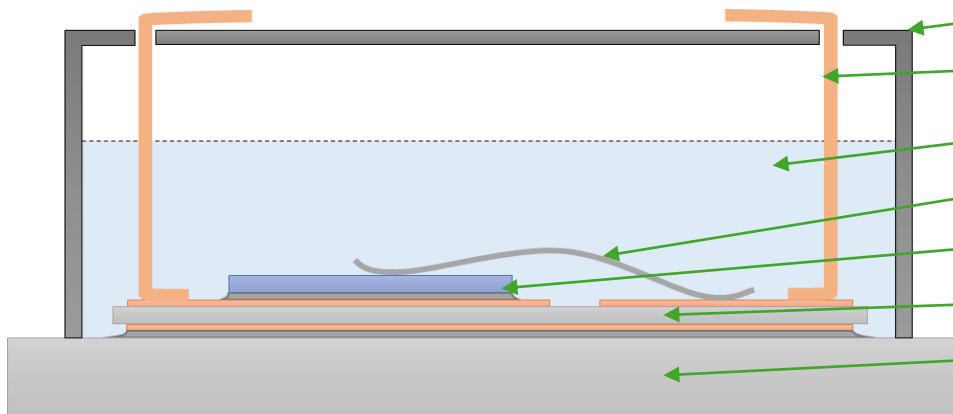

- Enclosure / case
- Terminals
- Encapsulant
- Wire bonding
- Die (SiC MOSFET)
- Metallized substrate
- Baseplate
- Solder Layers

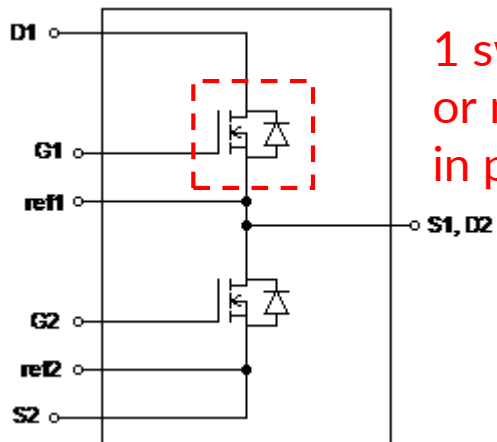

1 switch = 1
or more dies
in parallel



Infineon XHP3
Package

Converter

→ Power Module

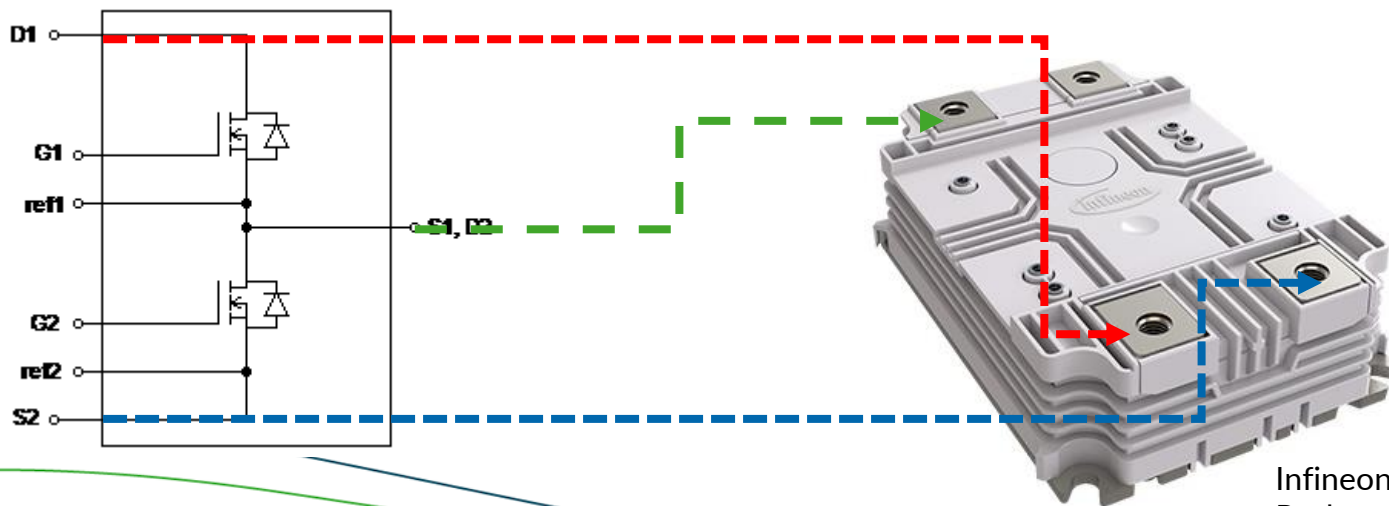
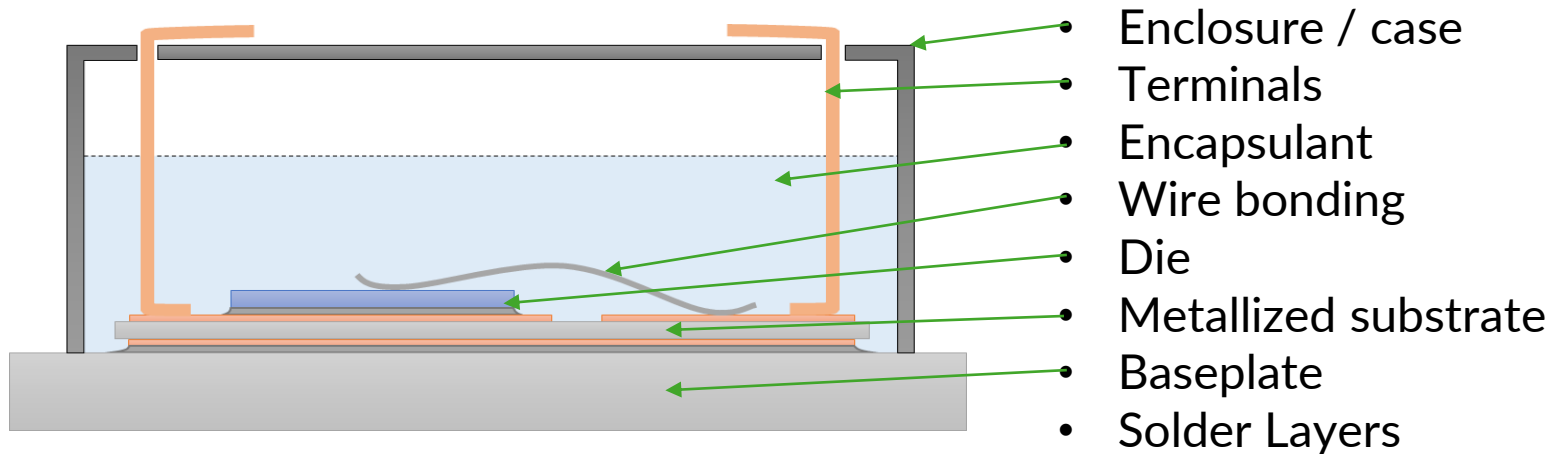

Infineon XHP3 Package

Converter

→ Power Module

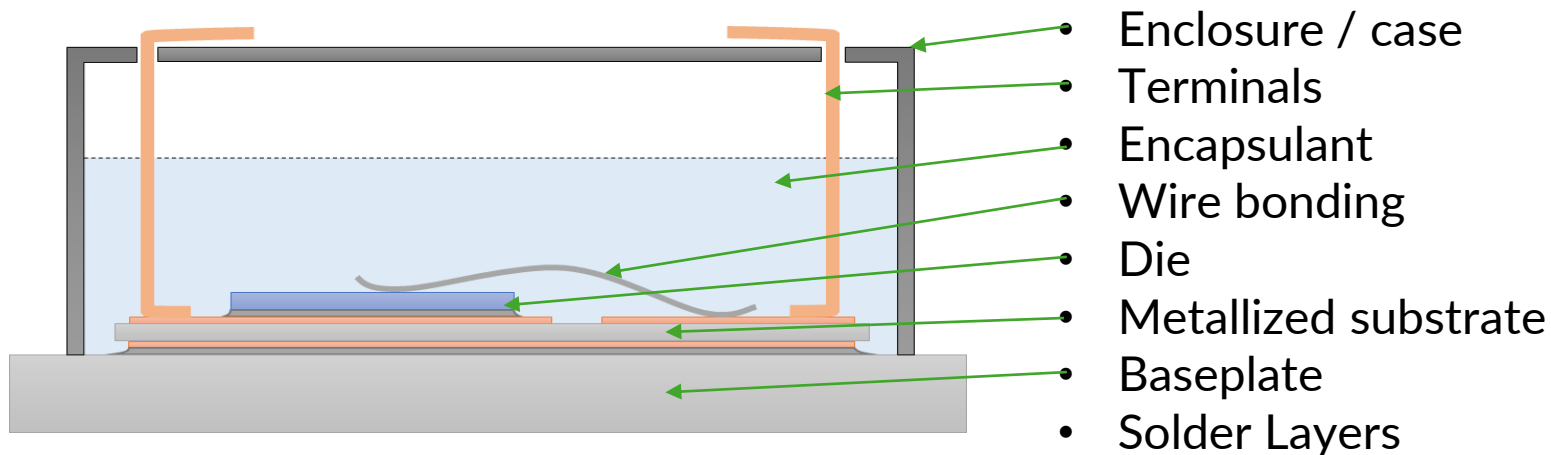

Part	Function	Material	Thickness (mm)	Thermal Conductivity (W/m.K)
Die	Electronic Switch	4H-SiC	0.4	270
Metallized Substrate	Interconnexion / Isolation / Heat path	Copper	0.3	400
		Ceramic (AlN)	0.635~1	150
		Copper	0.3	400
Baseplate	Mechanical support / Heat path	AlSiC	4	200
Solder Layers	Substrate Attach	Solder Alloy	0.1	35
	Die attach (classical)	Solder Alloy	0.05	35
	Die attach (advanced assembly)	Ag Sintered	0.05	200

Converter

→ Die R_{th} junction to case (isothermal backside)

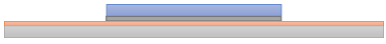
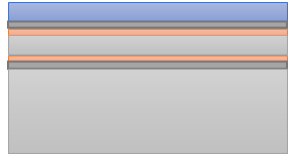
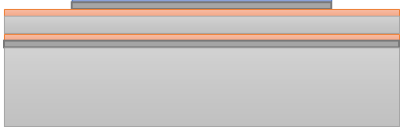
Ideal Case	Worst Case	Realistic Case
<ul style="list-style-type: none"> « Unlimited » heat spreading Optimized assembly, thinnest layers possible 	<ul style="list-style-type: none"> No heat spreading (dies touching each other) Typical layer thicknesses 	<ul style="list-style-type: none"> Reasonable distances between dies Typical layer thicknesses
		
$R_{th}=0.13 \text{ } ^\circ\text{C/W}$	$R_{th}=0.88 \text{ } ^\circ\text{C/W}$	$R_{th}=0.42 \text{ } ^\circ\text{C/W}$

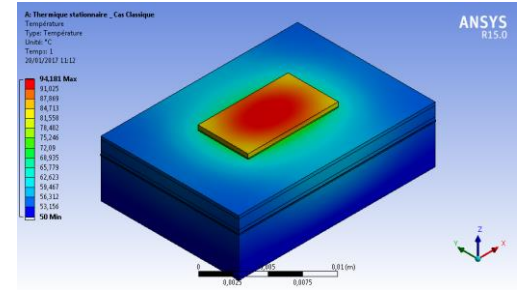
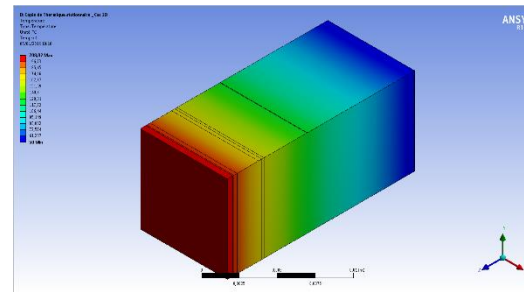
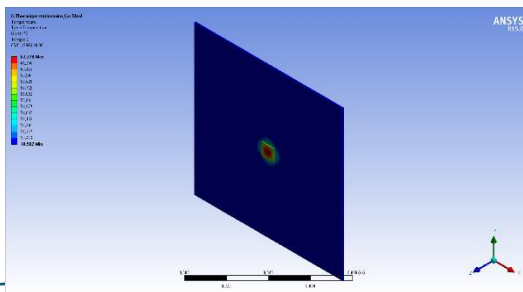

Converter

→ Die R_{th} junction to ambient

→ Isothermal Backside

➤ Simulation with actual geometry

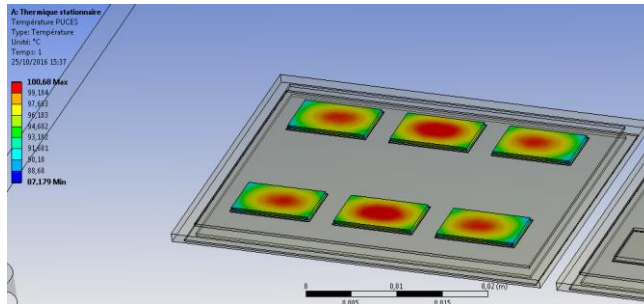

➤ $R_{th,j-c} = 0.42 \text{ } ^\circ\text{C/W}$

$T_C = 70 \text{ } ^\circ\text{C}$
 $T_j = 100 \text{ } ^\circ\text{C}$
 $P = 72 \text{ W}$

$$R_{th} = \frac{T_{j,max} - T_C}{P}$$

→ Heat Transfer Coefficient

➤ Closer to actual cooling system behavior

➤ Simulation with actual geometry

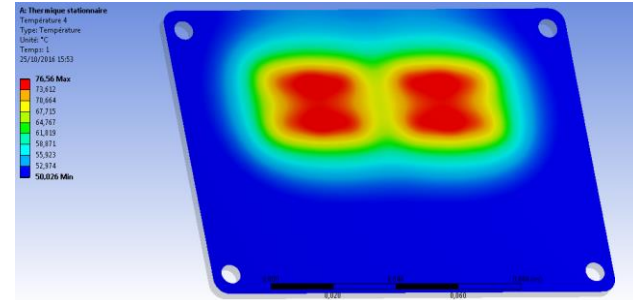

➤ CFD Calculations from the LCP Supplier

$R_{th,j-amb} = 0.63 \text{ } ^\circ\text{C/W}$

$$R_{th,j-A} = \frac{T_j - T_A}{P}$$

Converter

→ Die R_{th} , junction to ambient

➤ Temperature distribution:

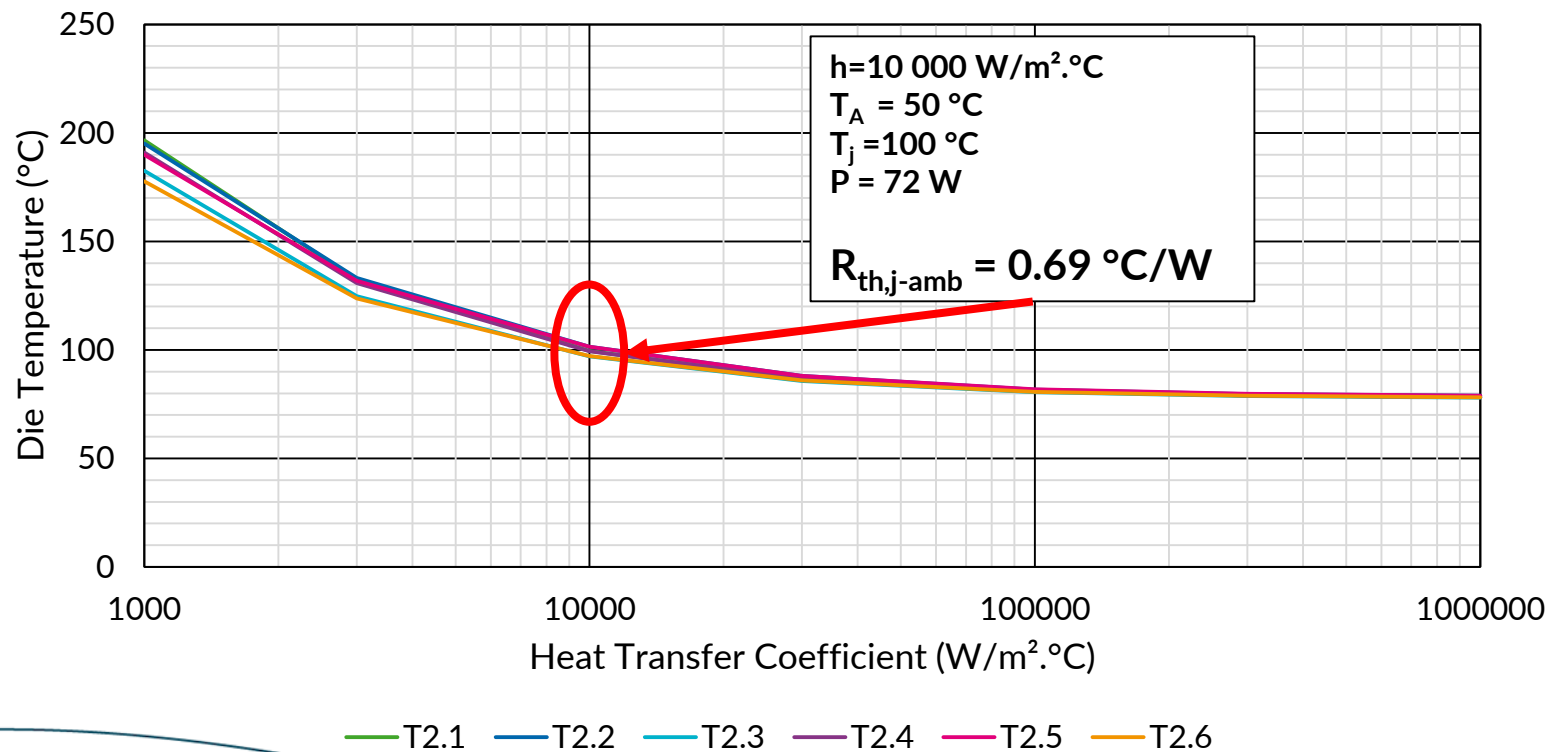

Thermal behavior of SiC MOSFETs

→ Thermal modelisation: SiC MOSFET

➤ Hypothesis:

- The main contribution to the On-resistance is the drift region
- The switching losses are not considered in this model

$$\mu_n(T_j) = 1140 \left(\frac{T_j}{300} \right)^{-\alpha}$$

$$R_{DRIFT,sp}(T_j) = \frac{W_D}{q \times N_D \times \mu_n(T_j)}$$

$$R_{on}(T_j) = R_{on,300K} \times \left(\frac{T_j}{300} \right)^{\alpha}$$

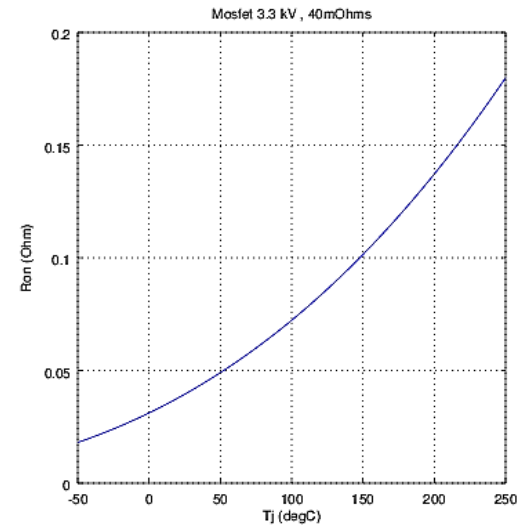
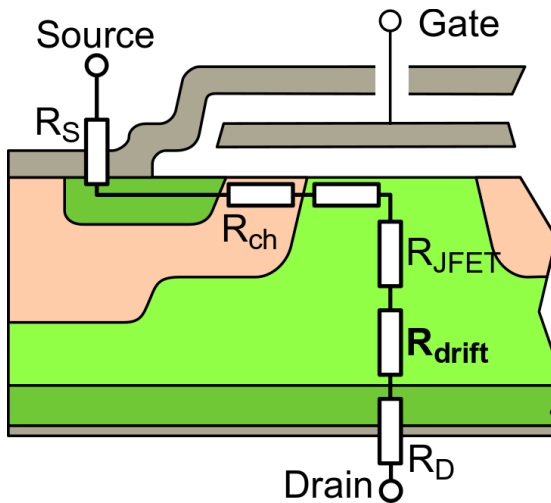

- The theoretical model is close to the datasheet Ron(Tj) characteristic (coefficient of determination $R^2=0,995$)

Thermal behavior of SiC MOSFETs

→ Thermal runaway:

► Power dissipated by the SiC MOSFET

$$\begin{aligned} P_{on}(T_j) &= R_{on}(T_j) \times I^2 \\ &= R_{on,300K} \times \left(\frac{T_j}{300}\right)^\alpha \times I^2 \end{aligned}$$

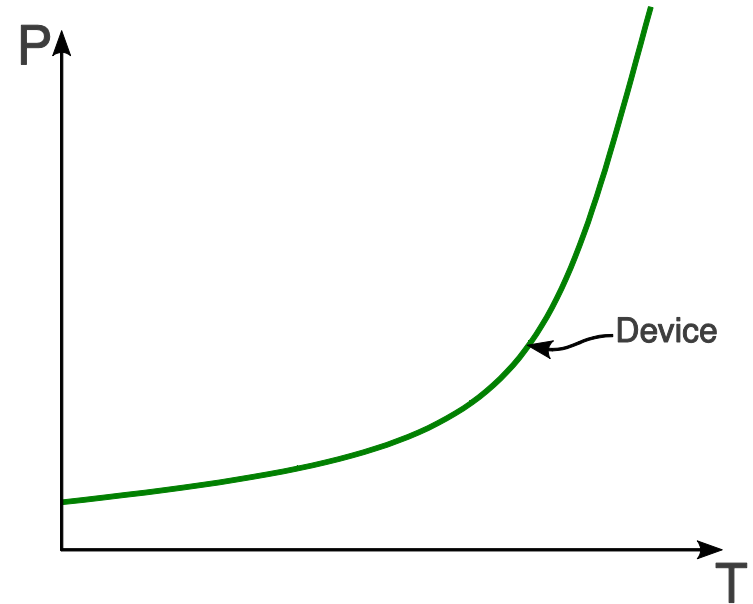

Thermal behavior of SiC MOSFETs

→ Thermal runaway:

➤ Power dissipated by the SiC MOSFET

$$\begin{aligned} P_{on}(T_j) &= R_{on}(T_j) \times I^2 \\ &= R_{on,300K} \times \left(\frac{T_j}{300}\right)^\alpha \times I^2 \end{aligned}$$

➤ Heat flow through the cooling system

$$P_{th}(T_j) = \frac{T_j - T_A}{R_{th}}$$

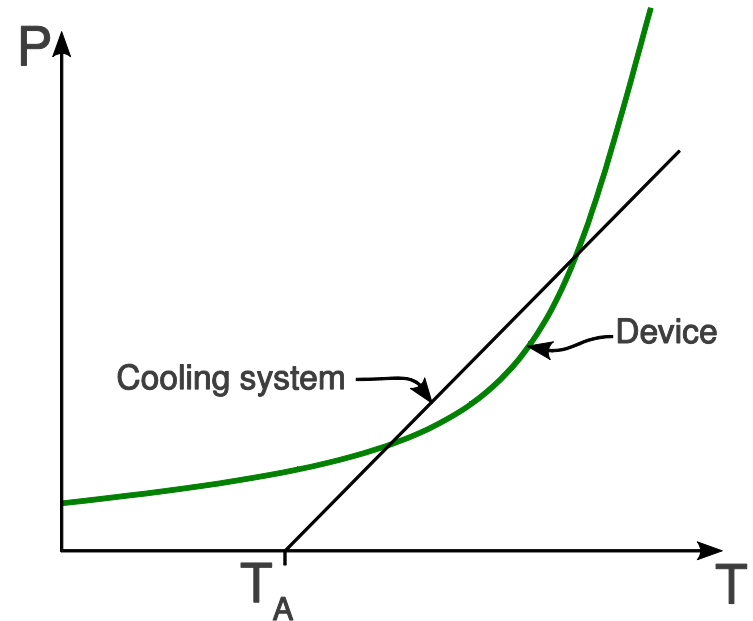

Thermal behavior of SiC MOSFETs

→ Thermal runaway:

➤ Power dissipated by the SiC MOSFET

$$\begin{aligned} P_{on}(T_j) &= R_{on}(T_j) \times I^2 \\ &= R_{on,300K} \times \left(\frac{T_j}{300}\right)^\alpha \times I^2 \end{aligned}$$

➤ Heat flow through the cooling system

$$P_{th}(T_j) = \frac{T_j - T_A}{R_{th}}$$

➤ Steady-state conditions:

$$\delta U(T_j) = P_{on}(T_j) - P_{th}(T_j) = 0$$

$\delta U = 0 \rightarrow$ **Stable steady – state**

$\delta U > 0 \rightarrow$ **Device Heating**

$\delta U < 0 \rightarrow$ **Device Cooling**

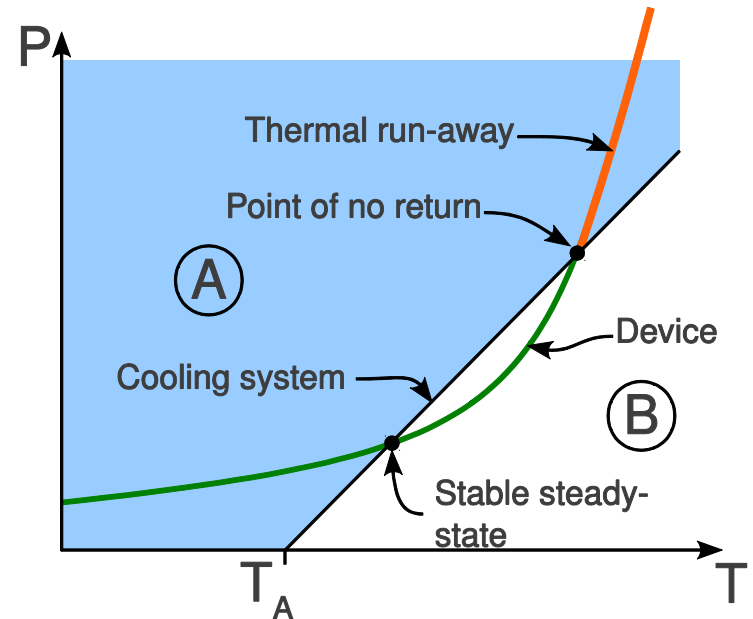

Thermal behavior of SiC MOSFETs

→ Thermal runaway:

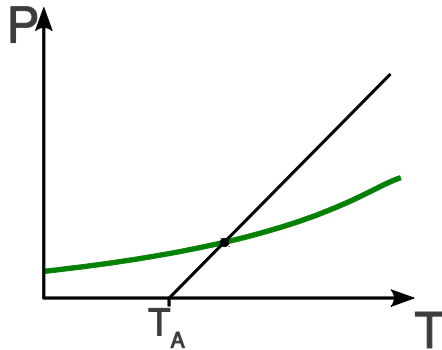

Stable

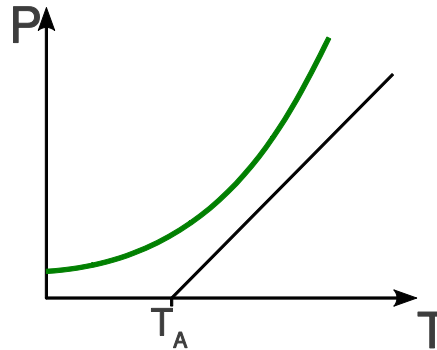

Unstable

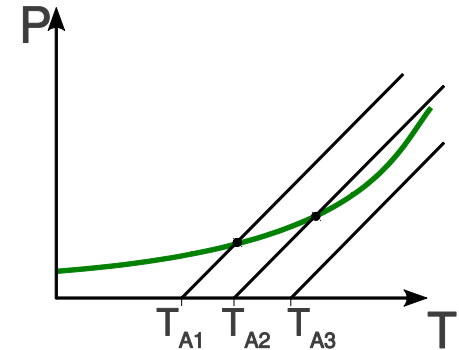

Stable to Unstable
with ambient
temperature
increasing

$\delta U = 0 \rightarrow$ *Stable steady – state*

$\delta U > 0 \rightarrow$ *Device Heating*

$\delta U < 0 \rightarrow$ *Device Cooling*

Thermal behavior of SiC MOSFETs

→ Paralleling of the MOSFETs

> Required to increase the current rating of the module

- $R_{on,Module} = \frac{R_{on,die}}{N_{dies}}$

> Thermal balancing

- Positive heat coefficient

- $V = V_a = V_b = V_c = constant$

- $I = I_a + I_b + I_c = constant$

If $R_a \uparrow$ then $I_a \downarrow$

If $I_a \downarrow$ then $I_b \uparrow$ and $I_c \uparrow$

$$\triangleright T_j \uparrow \Rightarrow R_{on} \uparrow \Rightarrow I_{die} \downarrow \Rightarrow P_{die} \downarrow \Rightarrow T_j \downarrow$$

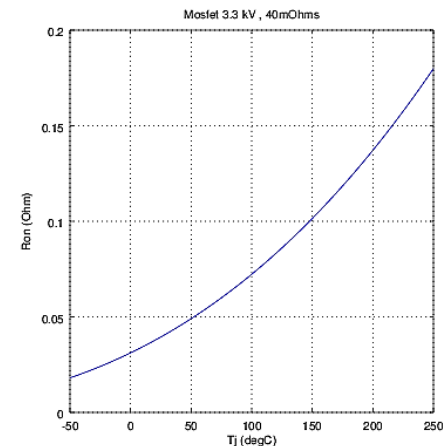
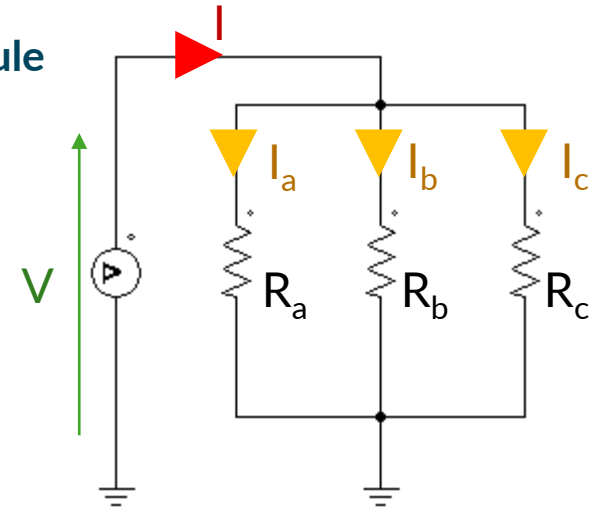

Thermal behavior of SiC MOSFETs

→ Paralleling the MOSFETs

- Ideal case: $R_{th,die} = 0,13 \text{ } ^\circ\text{C/W}$

T_j Calculation for 2 dies ignoring the $R_{on}(T_j)$ variations:

$$R_{on} = 40 \text{ m}\Omega$$

$$I_{module} = 200 \text{ A} \Rightarrow I_{die} = \frac{200}{2} = 100 \text{ A}$$

$$P_{die} = I_{die}^2 \times R_{on} = \left(\frac{200}{2}\right)^2 \times 0.04 = 400 \text{ W}$$

$$\Delta T = P_{die} \times R_{th} = 52 \text{ } ^\circ\text{C}$$

$$T_j = T_A + \Delta T = 92 \text{ } ^\circ\text{C}$$

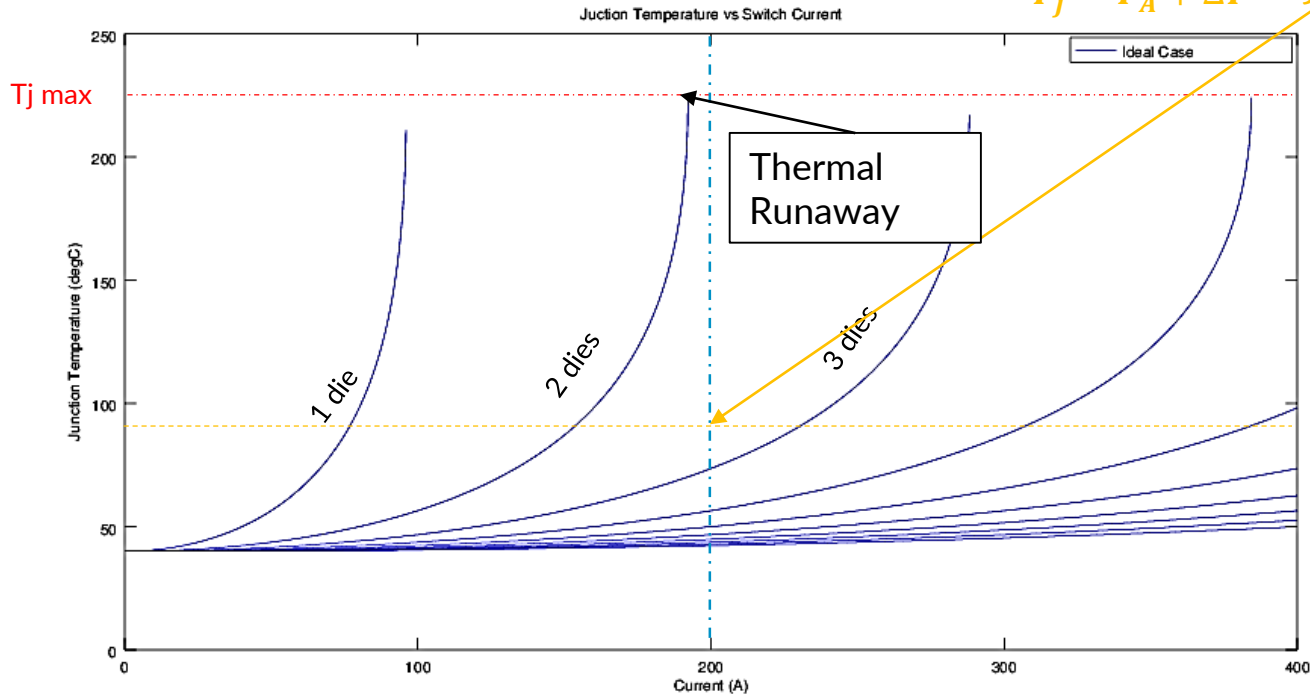

Thermal behavior of SiC MOSFETs

→ Paralleling the MOSFETs

- Realistic case: $R_{th,die} = 0,69 \text{ } ^\circ\text{C/W}$

T_j Calculation for 5 dies ignoring the $R_{on}(T_j)$ variations:

$$R_{on} = 40 \text{ m}\Omega$$

$$I_{module} = 200 \text{ A} \Rightarrow I_{die} = \frac{200}{5} = 40 \text{ A}$$

$$P_{die} = I_{die}^2 \times R_{on} = \left(\frac{200}{5}\right)^2 \times 0.04 = 64 \text{ W}$$

$$\Delta T = P_{die} \times R_{th} = 44 \text{ } ^\circ\text{C}$$

$$T_j = T_A + \Delta T = 84 \text{ } ^\circ\text{C}$$

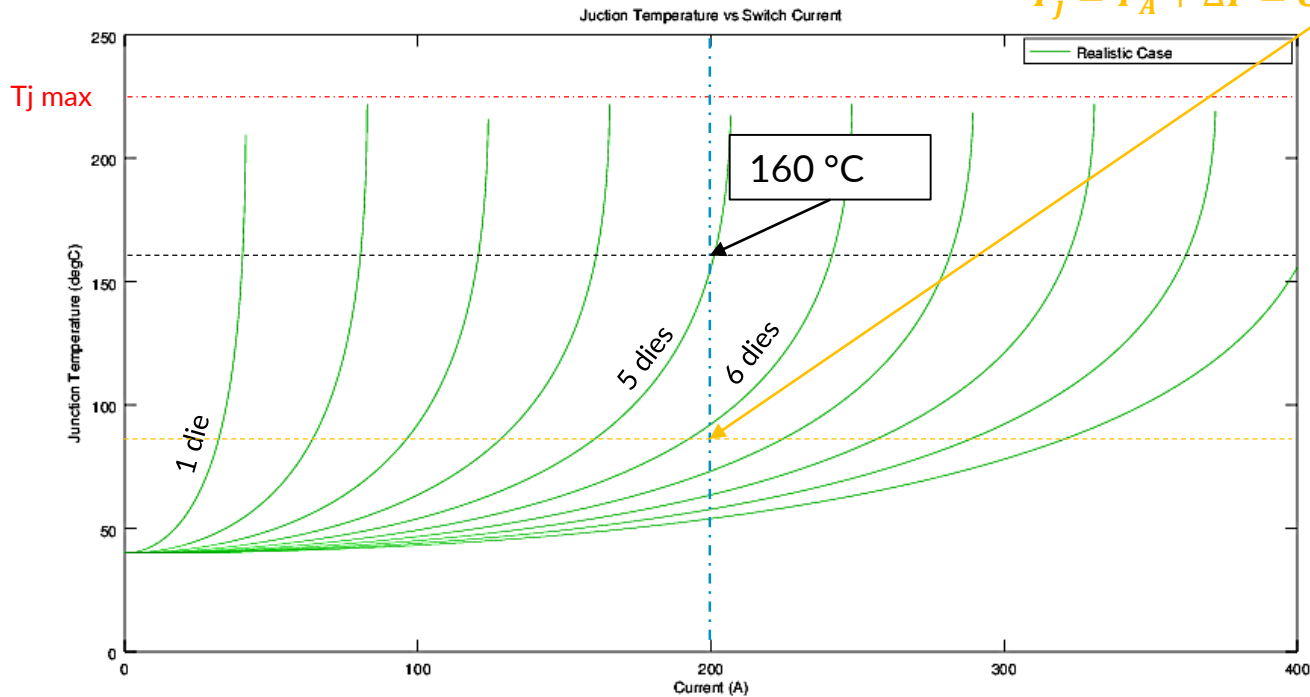

Thermal behavior of SiC MOSFETs

→ Paralleling the MOSFETs

- Worst case: $R_{th,die} = 0,88 \text{ } ^\circ\text{C/W}$

T_j Calculation for 8 dies ignoring the $R_{on}(T_j)$ variations:

$$R_{on} = 40 \text{ m}\Omega$$

$$I_{module} = 200 \text{ A} \Rightarrow I_{die} = \frac{200}{8} = 25 \text{ A}$$

$$P_{die} = I_{die}^2 \times R_{on} = \left(\frac{200}{8}\right)^2 \times 0.04 = 25 \text{ W}$$

$$\Delta T = P_{die} \times R_{th} = 22 \text{ } ^\circ\text{C}$$

$$T_j = T_A + \Delta T = 62 \text{ } ^\circ\text{C}$$

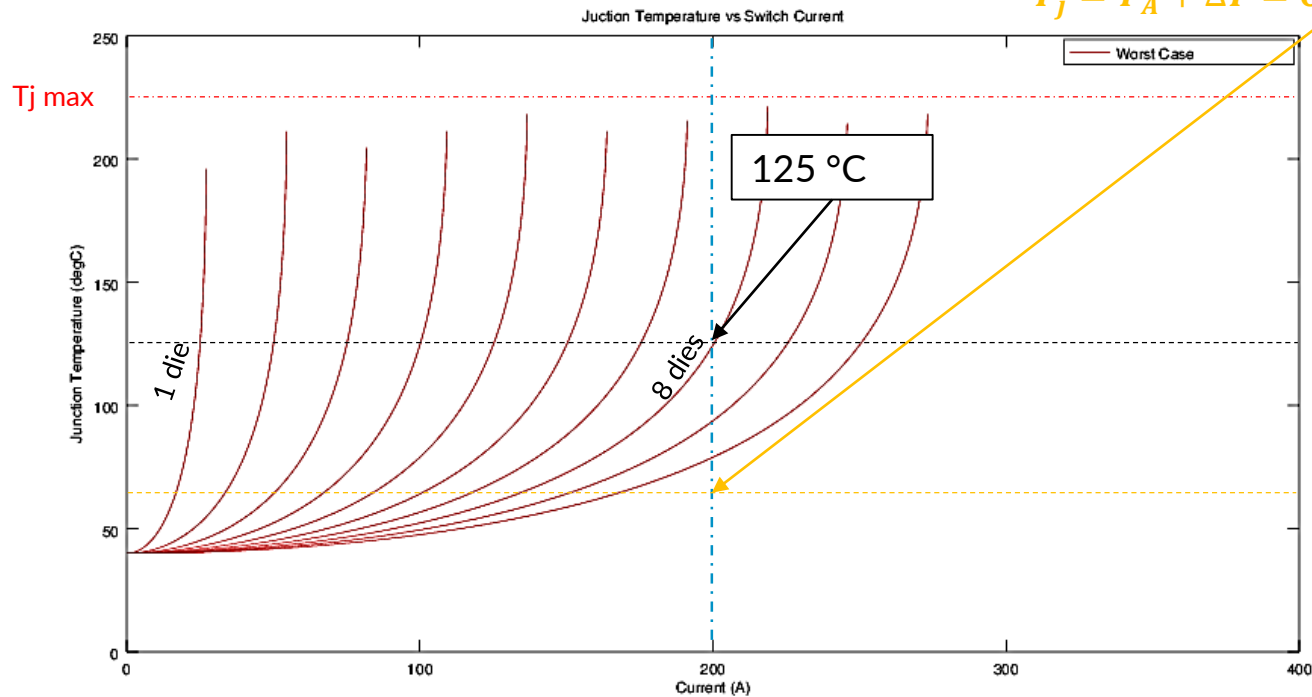

Economic Analysis

→ Parameters

- ❖ **3300V 40mΩ die, engineering sample**
 - 330\$ per unit (Source: PowerAmerica)
- ❖ **3300V 40mΩ die, volume production**
 - 140\$ per unit (Source: CREE commercial roadmap)
- ❖ **Wind electricity price**
 - 13 c€/kWh for the 1st 10 years
 - 3 c€/kWh after
- **Trade-off:**
 - More dies in parallel: Lower losses, more electricity produced but higher investment
 - Fewer dies in parallel: More losses but lower investment
- **Increasing the cooling performances is equivalent to increase die count**

Economic Analysis

COST-BENEFIT ANALYSIS (capitalized cost of energy: 13c€/kWh 1st 10 years, 3c€/kWh after)

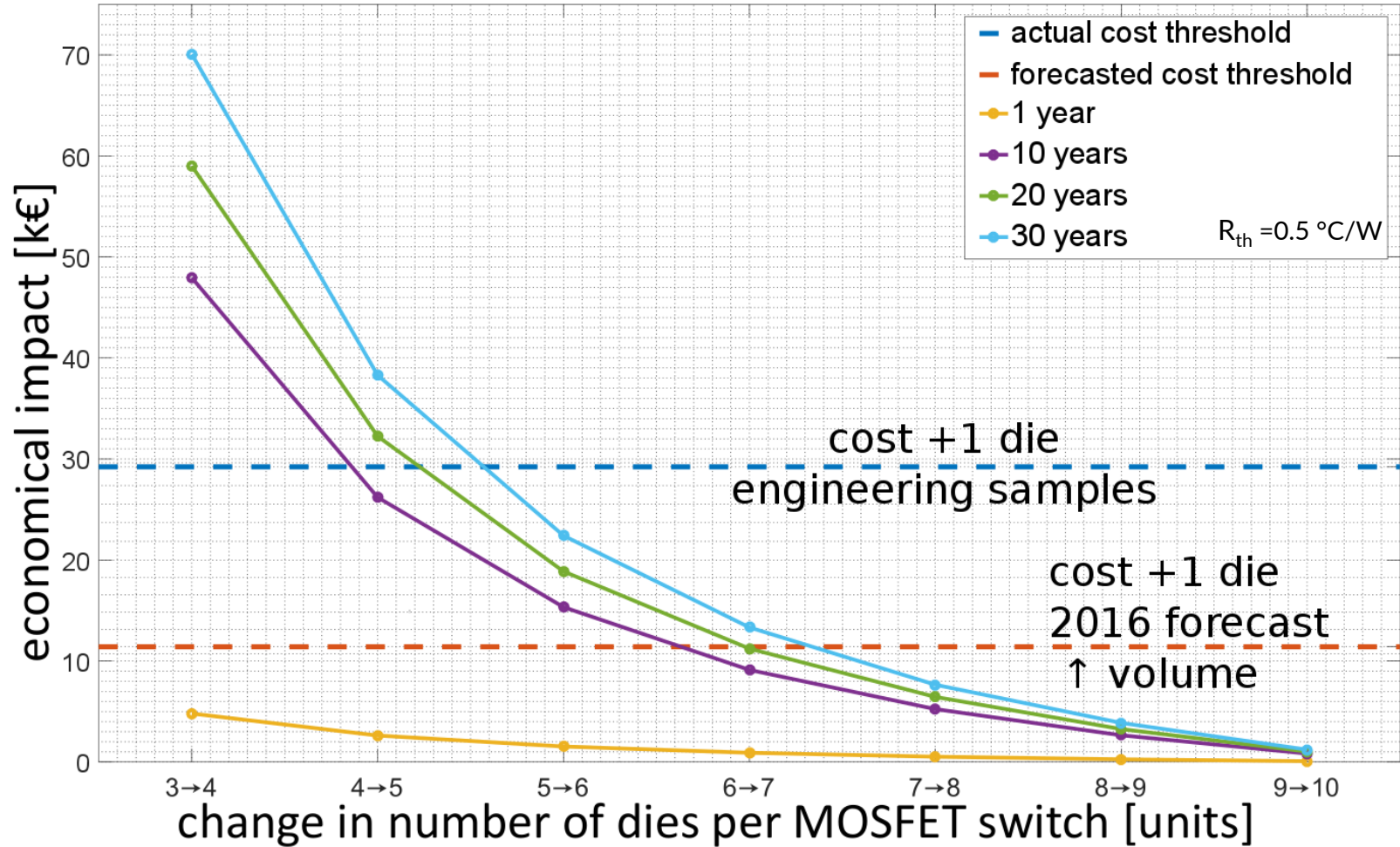

Conclusions

- SiC Dies can operate at high ($>150^{\circ}\text{C}$) junction temperature but $<100^{\circ}\text{C}$ is preferable for better efficiency
- Actual number of dies to be used is a trade-off between number of dies and energy savings
- Better cooling allows for fewer dies to be used.
 - We're interested in more efficient cooling techniques!

Acknowledgement

- This work was supported by a grant overseen by the French National Research Agency (ANR) as part of the “Investissements d’Avenir” Program (ANE-ITE-002-01)
- SuperGrid Institute



Thank you for your attention

→ Q&A

hugo.reynes@supergrid-institute.com

<http://www.supergrid-institute.com/>

