



HAL
open science

Scaling limit of the uniform prudent walk

Nicolas Pétrélis, Rongfeng Sun, Torri Niccolo

► **To cite this version:**

Nicolas Pétrélis, Rongfeng Sun, Torri Niccolo. Scaling limit of the uniform prudent walk. *Electronic Journal of Probability*, 2017, 22 (66), pp.1 - 19. 10.1214/17-EJP87 . hal-01470125v2

HAL Id: hal-01470125

<https://hal.science/hal-01470125v2>

Submitted on 7 Sep 2017

HAL is a multi-disciplinary open access archive for the deposit and dissemination of scientific research documents, whether they are published or not. The documents may come from teaching and research institutions in France or abroad, or from public or private research centers.

L'archive ouverte pluridisciplinaire **HAL**, est destinée au dépôt et à la diffusion de documents scientifiques de niveau recherche, publiés ou non, émanant des établissements d'enseignement et de recherche français ou étrangers, des laboratoires publics ou privés.

Scaling limit of the uniform prudent walk

Nicolas Pétrélis* Rongfeng Sun† Niccolò Torri‡

Abstract

We study the 2-dimensional uniform prudent self-avoiding walk, which assigns equal probability to all nearest-neighbor self-avoiding paths of a fixed length that respect the prudent condition, namely, the path cannot take any step in the direction of a previously visited site. The uniform prudent walk has been investigated with combinatorial techniques in [3], while another variant, the kinetic prudent walk has been analyzed in detail in [2]. In this paper, we prove that the 2-dimensional uniform prudent walk is ballistic and follows one of the 4 diagonals with equal probability. We also establish a functional central limit theorem for the fluctuations of the path around the diagonal.

Keywords: self-avoiding walk; prudent walk; scaling limits.

AMS MSC 2010: Primary 82B41, Secondary 60F05; 60K35.

Submitted to EJP on February 21, 2017, final version accepted on July 26, 2017.

Supersedes arXiv:1702.04915.

Supersedes HAL : hal - 01470125.

1 Introduction

The prudent walk was introduced in [9, 8] and [7] as a simplified version of the self-avoiding walk. It has attracted the attention of the combinatorics community in recent years, see e.g., [3, 1, 4], and also the probability community, see e.g. [2] and [6].

In dimension 2, for a given $L \in \mathbb{N}$, the set Ω_L of L -step prudent path on \mathbb{Z}^2 contains all nearest-neighbor self-avoiding path starting from the origin, which never take any step in the direction of a site already visited, i.e.,

$$\begin{aligned} \Omega_L := \{(\pi_i)_{i=0}^L \in (\mathbb{Z}^2)^{L+1} : \pi_0 = (0, 0), \pi_{i+1} - \pi_i \in \{\leftarrow, \rightarrow, \downarrow, \uparrow\} \quad \forall i \in \{0, \dots, L-1\}, \\ (\pi_i + \mathbb{N}(\pi_{i+1} - \pi_i)) \cap \pi_{[0,i]} = \emptyset \quad \forall i \in \{0, \dots, L-1\}\} \end{aligned} \quad (1.1)$$

where $\pi_{[0,i]}$ is the range of π at time i , i.e., $\pi_{[0,i]} = \{\pi_j : 0 \leq j \leq i\}$.

Two natural laws can be considered on Ω_L :

*Université de Nantes, Laboratoire de Mathématiques Jean Leray UMR 6629, 2 Rue de la Houssinière, F-44322 Nantes Cedex 03, France. E-mail: nicolas.petrelis@univ-nantes.fr

†National University of Singapore, NUS, Singapore. E-mail: matsr@nus.edu.sg

‡Université de Nantes, Laboratoire de Mathématiques Jean Leray UMR 6629, 2 Rue de la Houssinière, F-44322 Nantes Cedex 03, France. E-mail: niccolo.torri@univ-nantes.fr

1. The *uniform* law $\mathbf{P}_{\text{unif},L}$, also referred to as the uniform prudent walk, under which at every path in Ω_L is assigned equal probability $1/|\Omega_L|$;
2. The *kinetic* law $\mathbf{P}_{\text{kin},L}$, also referred to as the kinetic prudent walk, under which each step of the path is chosen uniformly among all the admissible steps. Note that the first step is in one of the 4 directions with equal probability. Subsequently, if a step increases either the width or the height of its range, then the next step has 3 admissible choices; otherwise there are only 2 admissible choices. Let $\mathcal{H}(\pi_{[0,L-1]})$ and $\mathcal{W}(\pi_{[0,L-1]})$ denote the height and width of the range of $\pi_{[0,L-1]}$. Then, for $L \in \mathbb{N}$ and $\pi \in \Omega_L$, we note that

$$\mathbf{P}_{\text{kin},L}(\pi) = \frac{1}{4} \left(\frac{1}{2}\right)^{L-\mathcal{H}(\pi_{[0,L-1]})-\mathcal{W}(\pi_{[0,L-1]})} \left(\frac{1}{3}\right)^{\mathcal{H}(\pi_{[0,L-1]})+\mathcal{W}(\pi_{[0,L-1]})}. \quad (1.2)$$

[2] proved that the scaling limit of the kinetic prudent walk is given by $Z_u = \int_0^{3u/7} (\sigma_1 1_{\{W_s \geq 0\}} \binom{1}{0} + \sigma_2 1_{\{W_s < 0\}} \binom{0}{1}) ds$, where W is a Brownian motion and $\sigma_1, \sigma_2 \in \{-1, 1\}$ are random signs (independent of W), cf. [2, Theorem 1].

In this paper, we identify rigorously the scaling limit of the 2-dimensional uniform prudent walk, proving a conjecture raised in several papers, e.g., [2, Section 5], and [3, Proposition 8] where partial answers were provided for the *2-sided* and *3-sided* versions of the 2-dimensional prudent walk using combinatorial techniques. The conjecture, supported by numerical simulations, was that when space and time are rescaled by the length L , the 2-dimensional uniform prudent walk converges to a straight line in one of the 4 diagonal directions chosen with equal probability. This is in stark contrast to the kinetic prudent walk.

2 Main results

Definition 2.1. For every $\pi \in \Omega_L$, let $\tilde{\pi}^L : [0, 1] \mapsto \mathbb{R}^2$ be the rescaled and interpolated version of π , i.e.,

$$\tilde{\pi}_t^L = \frac{1}{L} (\pi_{\lfloor tL \rfloor} + (tL - \lfloor tL \rfloor)(\pi_{\lfloor tL \rfloor + 1} - \pi_{\lfloor tL \rfloor})), \quad t \in [0, 1].$$

We also denote $\vec{e}_1 := (1, 1)$, $\vec{e}_2 := (-1, 1)$, $\vec{e}_3 := (-1, -1)$ and $\vec{e}_4 := (1, -1)$.

Our first result shows that the scaling limit of the uniform prudent walk is a straight line segment.

Theorem 2.2 (Concentration along the diagonals). *There exists a $c > 0$ such that for every $\varepsilon > 0$*

$$\lim_{L \rightarrow \infty} \mathbf{P}_{\text{unif},L} \left(\exists i \in \{1, \dots, 4\} \text{ s.t. } \sup_{t \in [0,1]} |\tilde{\pi}_t^L - ct \vec{e}_i| \leq \varepsilon \right) = 1. \quad (2.1)$$

Furthermore, we can identify the fluctuation of the prudent walk around the diagonal. More precisely, let $\sigma_L = 1, 2, 3, 4$, depending on whether $\tilde{\pi}_1^L$ lies in the interior of the 1st, 2nd, 3rd, or the 4th quadrant, and let $\sigma_L = 0$ otherwise. Then we have

Theorem 2.3 (Fluctuations around the diagonal). *Under $\mathbf{P}_{\text{unif},L}$, the law of σ_L converges to the uniform distribution on $\{1, 2, 3, 4\}$, and*

$$\left(\sqrt{L}(\tilde{\pi}_t^L - ct \vec{e}_{\sigma_L}) \right)_{t \in [0,1]} \Rightarrow (B_t)_{t \in [0,1]} \quad \text{as } L \rightarrow \infty, \quad (2.2)$$

where \Rightarrow denotes weak convergence, and $(B_t)_{t \geq 0}$ is a two-dimensional Brownian motion with a non-degenerate covariance matrix, cf. (3.28).

The proof of Theorem 2.2 follows the strategy used by [2]. We consider the so called *uniform 2-sided prudent walk* (cf. Section 3), a sub-family of prudent walks with a fixed diagonal direction. First we prove that the scaling limit of the uniform 2-sided prudent walk is a straight line, cf. Theorem 3.1. A weaker version of this result was already proven by [3, Proposition 6]. We reinforce it by using an alternative probabilistic approach. We decompose a path into a sequence of excursions, which leads to an *effective* one-dimensional random walk with geometrical increments, see e.g., Figure 1. Then we show that under the uniform measure, a typical path of length L crosses its range from one end to the other at most $\log L$ times and the total length of the first $\log L$ excursions also grows at most logarithmically in L . This results refines the upper bound obtained by [6]. The excursions crossing the range of the walk disappear in the scaling limit, while the remaining part of the path is nothing but a uniform 2-sided prudent walk (in one of the four diagonal directions), for which we have identified the correct scaling limit.

Theorem 2.3 can be proved using the same strategy. Once it is shown to hold for the 2-sided uniform prudent walk, cf. Theorem 3.2, then it also holds for the uniform prudent walk thanks to control on the number of excursions crossing the range of the walk.

2.1 Organization of the paper

The article is organized as follows: In Section 3, we introduce the uniform 2-sided prudent walk and identify its scaling limit. In Section 4, we analyze the uniform prudent walk and prove some technical results needed to control the excursions crossing the range of the walk. Lastly, we prove our main results Theorems 2.2 and 2.3 in Section 5.

3 Uniform 2-sided prudent walk

Let Ω_L^+ be the subset of Ω_L containing the so called *2-sided* prudent path (in the north-east direction), that is, those paths $\pi \in \Omega_L$ satisfying three additional geometric constraints:

1. π can not take any step in the direction of any site in the quadrant $(-\infty, 0]^2$;
2. The endpoint π_L is located at the top-right corner of the smallest rectangle containing π ;
3. π starts with an east step (\rightarrow), i.e., $\pi_1 = (1, 0)$.

We denote by $\mathbf{P}_{\text{unif},L}^+$ the uniform measure on Ω_L^+ . Theorems 3.1 and 3.2 below are the counterparts of Theorems 2.2 and 2.3 for the uniform 2-sided prudent walk. Recall that $\vec{e}_1 = (1, 1)$.

Theorem 3.1. *There exists a $c > 0$ such that for every $\varepsilon > 0$,*

$$\lim_{L \rightarrow \infty} \mathbf{P}_{\text{unif},L}^+ \left(\sup_{t \in [0,1]} |\tilde{\pi}_t^L - ct \vec{e}_1| \leq \varepsilon \right) = 1. \tag{3.1}$$

Theorem 3.2. *Under $\mathbf{P}_{\text{unif},L}^+$,*

$$\left(\sqrt{L}(\tilde{\pi}_t^L - ct \vec{e}_1) \right)_{t \in [0,1]} \Rightarrow (B_t)_{t \in [0,1]} \quad \text{as } L \rightarrow \infty. \tag{3.2}$$

where B is the same two-dimensional Brownian motion as in Theorem 2.3.

3.1 Decomposition of a 2-sided prudent path into excursions

Every path $\pi \in \Omega_L^+$ can be decomposed in a unique manner into a sequence of horizontal and vertical excursions (see Figure 1). First we introduce some notation. For $\pi \in \Omega_L^+$ and $i \leq L$, denote $\pi_i = (\pi_{i,1}, \pi_{i,2})$. Let $\tau_0 := 0$ and

$$\tau_1(\pi) := \min\{i > 0 : \pi_{i,2} > 0\} - 1, \quad \tau_2(\pi) := \min\{i > \tau_1 : \pi_{i,1} > \pi_{\tau_1,1}\} - 1, \quad (3.3)$$

which are the times when the first horizontal, resp. vertical excursion ends. For $k \in \mathbb{N}$, define

$$\tau_{2k+1}(\pi) := \inf\{i > \tau_{2k} : \pi_{i,2} > \pi_{\tau_{2k},2}\} - 1, \quad \tau_{2k+2}(\pi) := \inf\{i > \tau_{2k+1} : \pi_{i,1} > \pi_{\tau_{2k+1},1}\} - 1.$$

Let $\gamma_L(\pi) := \min\{j \geq 1 : \tau_j(\pi) = \infty\}$ be the number of excursions in π . Note that each horizontal excursion starts with an east step, and each vertical excursion a north step. Since the endpoint π_L lies at the top-right corner of the smallest rectangle containing π , the last excursion of π can be made complete by adding an extra north step if it is a horizontal excursion, or adding an extra east step if it is a vertical excursion. Therefore, with a slight abuse of notation, we redefine $\tau_{\gamma_L} := L$. We can thus decompose π into the excursions $((\pi_{\tau_{k-1}}, \dots, \pi_{\tau_k}))_{k=1}^{\gamma_L}$, which are horizontal for odd k and vertical for even k .

3.2 Effective random walk excursion

Let \mathcal{I}_t denote the set of horizontal excursions of length t , flipped above the x -axis, i.e.,

$$\mathcal{I}_t := \left\{ \pi = (\pi_0, \pi_1, \dots, \pi_t) : \pi_0 = (0, 0), \pi_1 = (1, 0), \pi_{i,2} \geq 0 \forall i \in \{1, \dots, t\}, \pi_{t,2} = 0 \right\}. \quad (3.4)$$

Recall from Section 3.1 that each path $\pi \in \Omega_L^+$ can be decomposed uniquely into $\gamma_L(\pi)$ excursions of length $\tau_i - \tau_{i-1}$, $i = 1, \dots, \tau_L(\pi)$. These excursions are alternately horizontal and vertical, with the first excursion being horizontal, see Figure 1. We can thus partition Ω_L^+ according to the value of $r := \gamma_L(\pi)$ and the excursion lengths t_1, \dots, t_r . Defining

$$K(t) := \frac{1}{2^t} |\mathcal{I}_t|, \quad (3.5)$$

we have that

$$\frac{1}{2^L} |\Omega_L^+| = \sum_{r \geq 1} \sum_{t_1 + \dots + t_r = L} \prod_{i=1}^r |\mathcal{I}_{t_i}| \frac{1}{2^{t_i}} = \sum_{r \geq 1} \sum_{t_1 + \dots + t_r = L} \prod_{i=1}^r K(t_i). \quad (3.6)$$

We now follow the idea introduced in [2] and rewrite (3.5) in terms of a one-dimensional effective random walk $V = (V_i)_{i=0}^\infty$. The walk V starts from 0, has law \mathbf{P} , and its increments $(U_i)_{i=0}^\infty$ are i.i.d. and follow a discrete Laplace distribution, i.e.,

$$\mathbf{P}(U_1 = x) = \frac{1}{3} \frac{1}{2^{|x|}}, \quad x \in \mathbb{Z}. \quad (3.7)$$

Lemma 3.3. *Given the walk V and $t \in \mathbb{N}$, let $\eta_t := \min\{i \geq 1 : i + \sum_{j=1}^i |U_j| \geq t\}$, then*

$$K(t) = \mathbf{E} \left[e^{\log(\frac{3}{2}) \eta_t} \mathbf{1}_{\{V_i \geq 0 \forall i \leq \eta_t, V_{\eta_t} = 0, \eta_t + \sum_{j=1}^{\eta_t} |U_j| = t\}} \right]. \quad (3.8)$$

Proof. For each $\pi \in \mathcal{I}_t$ (cf. (3.4)), let $n(\pi) := |\pi_{t,1} - \pi_{0,1}|$ be the number of horizontal steps. Each horizontal step is followed by a stretch of vertical steps, and for $1 \leq i \leq n$, let $\ell_i \in \mathbb{Z}$ denote the vertical displacement after the i -th horizontal step. This gives a bijection between \mathcal{I}_t and $\bigcup_{n=1}^t \mathcal{L}_{n,t}$, where

$$\mathcal{L}_{n,t} := \left\{ \underline{\ell} = (\ell_1, \dots, \ell_n) \in \mathbb{Z}^n : \sum_{k=1}^j \ell_k \geq 0 \forall j = 1, \dots, n, \sum_{k=1}^n \ell_k = 0, n + \sum_{j=1}^n |\ell_j| = t \right\}. \quad (3.9)$$

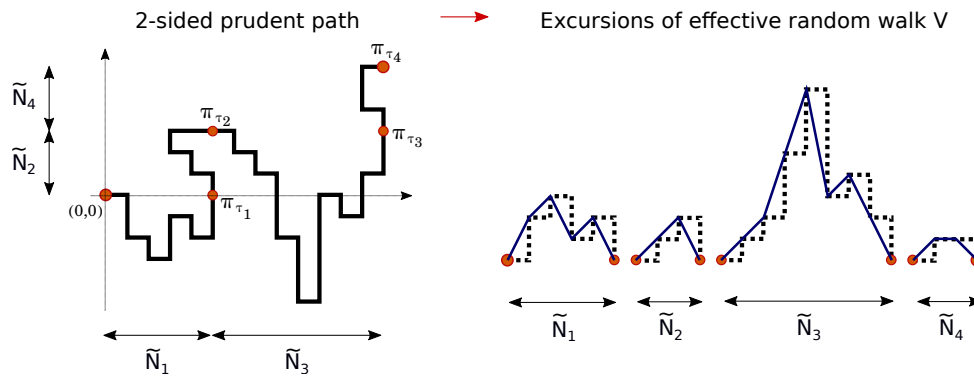

Figure 1: We decompose a path $\pi \in \Omega_L^+$ into a sequence of horizontal and vertical excursions $((\pi_{\tau_{k-1}}, \dots, \pi_{\tau_k}))_{k=1}^4$, each associated with an effective one dimensional random walk excursion.

At this stage we note that

$$\frac{1}{2^t} |\mathcal{I}_t| = \sum_{\pi \in \mathcal{I}_t} \frac{1}{2^{t-n(\pi)}} \frac{1}{3^{n(\pi)}} \left(\frac{3}{2}\right)^{n(\pi)} = \sum_{n=1}^t \sum_{\underline{\ell} \in \mathcal{L}_{n,t}} \frac{1}{3^n} \frac{1}{2^{\sum_{j=1}^n |\ell_j|}} e^{n \log(\frac{3}{2})}. \tag{3.10}$$

By identifying $\underline{\ell} = (\ell_1, \dots, \ell_n)$ in (3.10) with the increments of V , we get (3.8). □

3.3 Representation of the law of a uniform 2-sided prudent walk

Lemma 3.4. *Let K be as in (3.8), then there exists $\lambda^* > 0$ such that $\widehat{K}(\lambda^*) := \sum_{t=1}^\infty K(t)e^{-\lambda^*t} = 1$.*

Remark 3.5. We will denote by K^* the probability measure on \mathbb{N} defined by

$$K^*(t) = K(t)e^{-\lambda^*t}, \quad t \in \mathbb{N}. \tag{3.11}$$

The proof of Lemma 3.4 below shows that there exists $\hat{\lambda} < \lambda^*$ such that $1 < \widehat{K}(\hat{\lambda}) < \infty$. Therefore K^* has exponential tail, i.e., there exist $c_1, c_2 > 0$ such that $K^*(n) \leq c_1 e^{-c_2 n}$ for every $n \in \mathbb{N}$.

The proof of Lemma 3.4 will be given at the end of the present section. We first explain how the law K^* can be used to express the law \mathbf{P}^* of the excursions of the uniform two-sided prudent walk. Continuing Section 3.2, let \mathcal{V}_∞ be the set of all non-negative excursions of the effective walk, i.e.,

$$\mathcal{V}_\infty := \bigcup_{N \geq 1} \left\{ (V_i)_{i=0}^N : V_0 = 0, V_i \geq 0 \forall i \leq N, V_N = 0 \right\}. \tag{3.12}$$

By (3.8) and Lemma 3.4, we obtain the following probability law \mathbf{P}^* on \mathcal{V}_∞ , with Radon-Nikodym derivative

$$\frac{d\mathbf{P}^*}{d\mathbf{P}} \left((V_i)_{i=0}^N \right) = e^{\log(\frac{3}{2})N - \lambda^*(N + \sum_{i=1}^N |U_i|)}. \tag{3.13}$$

We will show that \mathbf{P}^* is in fact the law of a uniform 2-sided prudent walk excursion. To that end, consider a sequence $(t_i, n_i)_{i=1}^r \in \mathbb{N}^r \times \mathbb{N}^r$ satisfying $t_1 + \dots + t_r = L$ and $n_i \leq t_i$ for every $i \leq r$. Let $\Omega_L^+((t_i, n_i)_{i=1}^r)$ denote the set of 2-sided prudent path consisting of r excursions, where the i -th excursion has total length t_i , with n_i horizontal (resp. vertical)

steps if it is a horizontal (resp. vertical) excursion. By the reasoning leading to (3.6), with $\alpha^* := \log(3/2) - \lambda^*$, we obtain

$$\frac{1}{2^L} |\Omega_L^+((t_i, n_i)_{i=1}^r)| e^{-\lambda^* L} = \prod_{i=1}^r \mathbf{E} \left[e^{\alpha^* n_i - \lambda^* (t_i - n_i)} \mathbf{1}_{\{V_j \geq 0 \forall j \leq n_i, V_{n_i} = 0, n_i + \sum_{j=1}^{n_i} |U_j| = t_i\}} \right]. \tag{3.14}$$

If $(\tilde{T}_i, \tilde{N}_i)_{i \in \mathbb{N}}$ denotes an i.i.d. sequence such that $\tilde{N}_1 = N$ and $\tilde{T}_1 = N + \sum_{i=1}^N |U_i|$ for a random walk excursion $(V_i)_{i=0}^N$ following the law \mathbf{P}^* in (3.13), and

$$\tilde{\gamma}_L := \min\{i \geq 1 : \tilde{T}_1 + \dots + \tilde{T}_i \geq L\}, \tag{3.15}$$

then by (3.6) and (3.14), for any set of paths A which is a union of some $\Omega_L^+((t_i, n_i)_{i=1}^r)$, we have

$$\mathbf{P}_{\text{unif}, L}^+(A) = \frac{|\Omega_L^+(A)|}{|\Omega_L^+|} = \frac{\mathbf{E}^* \left[\mathbf{1}_{A \cap \{\tilde{T}_1 + \dots + \tilde{T}_{\tilde{\gamma}_L} = L\}} \right]}{\mathbf{P}^* \left[\tilde{T}_1 + \dots + \tilde{T}_{\tilde{\gamma}_L} = L \right]}, \tag{3.16}$$

where we also used \mathbf{P}^* to denote the joint law of the i.i.d. sequence of effective random walk excursions that give rise to $(\tilde{T}_i, \tilde{N}_i)_{i \in \mathbb{N}}$. This representation will be the basis of our analysis.

Proof of Lemma 3.4. The existence of λ^* is guaranteed if $\lambda^{**} := \inf\{\lambda > 0 : \widehat{K}(\lambda) < \infty\}$ satisfies $\widehat{K}(\lambda^{**}) > 1$. To show this, let τ be the first time the walk V returns to or crosses the origin, i.e.,

$$\tau = \begin{cases} 1 & \text{if } V_1 = 0, \\ \min\{i \geq 2 : V_{i-1} V_i \leq 0\} & \text{otherwise.} \end{cases} \tag{3.17}$$

Let $\alpha := \log(3/2) - \lambda$. By (3.8) and decomposing $V \in \mathcal{V}_\infty$ into positive excursions, we can write

$$\begin{aligned} \widehat{K}(\lambda) &= \sum_{t \geq 1} \mathbf{E} \left[e^{(\log(\frac{3}{2}) - \lambda) \eta_t - \lambda(t - \eta_t)} \mathbf{1}_{\{V_i \geq 0 \forall i \leq \eta_t, V_{\eta_t} = 0, \eta_t + \sum_{i=1}^{\eta_t} |U_i| = t\}} \right] \\ &= \sum_{t \geq 1} \sum_{N \leq t} \mathbf{E} \left[e^{\alpha N - \lambda(t - N)} \mathbf{1}_{\{V_i \geq 0 \forall i \leq N, V_N = 0, N + \sum_{i=1}^N |U_i| = t\}} \right] \\ &= \sum_{N=1}^{\infty} \mathbf{E} \left[e^{\alpha N} e^{-\lambda \sum_{i=1}^N |U_i|} \mathbf{1}_{\{V_i \geq 0 \forall i \leq N, V_N = 0\}} \right] \\ &= \sum_{N=1}^{\infty} \sum_{r=1}^{\infty} \sum_{n_1 + \dots + n_r = N} \prod_{i=1}^r \mathbf{E} \left[e^{\alpha \tau} e^{-\lambda \sum_{i=1}^{\tau} |U_i|} \mathbf{1}_{\{V_1 \geq 0, \tau = n_i, V_{n_i} = 0\}} \right] \\ &= \sum_{r=1}^{\infty} \left(\sum_{n=1}^{\infty} \mathbf{E} \left[e^{\alpha \tau - \lambda \sum_{i=1}^{\tau} |U_i|} \mathbf{1}_{\{V_1 \geq 0, \tau = n, V_\tau = 0\}} \right] \right)^r \\ &= \sum_{r=1}^{\infty} \left(\mathbf{E} \left[e^{\alpha \tau - \lambda \sum_{i=1}^{\tau} |U_i|} \mathbf{1}_{\{V_1 \geq 0, V_\tau = 0\}} \right] \right)^r =: \sum_{r=1}^{\infty} G(\lambda)^r. \end{aligned} \tag{3.18}$$

Therefore $\lambda^{**} = \inf\{\lambda > 0 : G(\lambda) < 1\}$, and it suffices to show that $G(\lambda^{**}) > 1/2$. Note that

$$\mathbf{E} \left[e^{\alpha \tau - \lambda \sum_{i=1}^{\tau} |U_i|} \mathbf{1}_{\{V_1 = 0\}} \right] = \frac{e^\alpha}{3}, \tag{3.19}$$

and

$$\mathbf{E} \left[e^{\alpha \tau - \lambda \sum_{i=1}^{\tau} |U_i|} \mathbf{1}_{\{V_1 > 0, \tau = n\}} \right] = \mathbf{E} \left[e^{\alpha \tau - \lambda \sum_{i=1}^{\tau} |U_i|} \mathbf{1}_{\{V_1 > 0, \tau = n, V_\tau = 0\}} \right] \frac{1}{1 - e^{-\lambda/2}}, \tag{3.20}$$

because given $(V_i)_{i=0}^{n-1}$ with $V_1 > 0$, the events $\{\tau = n, V_n = 0\}$ and $\{\tau = n\}$ differ only in that the first event requires $U_n = -V_{n-1}$, while the second event requires $U_n \leq -V_{n-1}$, and the probability ratio of the two events is precisely $\sum_{k=0}^{\infty} \frac{e^{-k\alpha}}{2^k} = \frac{1}{1-e^{-\lambda/2}}$ by (3.7). Summing over n in (3.20), using the symmetry of V and (3.19) then gives

$$G(\lambda) = \frac{e^\alpha}{3} \left(\frac{1}{2} + \frac{e^{-\lambda}}{4} \right) + \frac{1}{2} \left(1 - \frac{e^{-\lambda}}{2} \right) \mathbf{E} \left[e^{\alpha\tau - \lambda \sum_{i=1}^{\tau} |U_i|} \right]. \tag{3.21}$$

Now let $\hat{\lambda}$ be the unique solution of

$$\log \mathbf{E}[e^{-\lambda|U_1|}] = -\alpha = \lambda - \log(3/2), \quad \lambda \in [0, \infty).$$

Then $(M_n^{\hat{\lambda}})_{n \geq 0} := (e^{\alpha n - \hat{\lambda} \sum_{i=1}^n |U_i|})_{n \geq 0}$ is a positive martingale. We will show that $\mathbf{E}[M_\tau^{\hat{\lambda}}] = 1$, which then gives $G(\hat{\lambda}) = \frac{1}{2} + \frac{e^{-2\hat{\lambda}}}{8} \in (1/2, 1)$. By definition, we have $\hat{\lambda} > \lambda^{**}$. Since $\lambda \mapsto G(\lambda)$ is strictly decreasing, we conclude that $G(\lambda^{**}) > G(\hat{\lambda}) > 1/2$.

It remains to prove that $\mathbf{E}[M_\tau^{\hat{\lambda}}] = 1$. Note that τ is an almost surely finite stopping time, so that $M_{n \wedge \tau}^{\hat{\lambda}}$ converges almost surely to $M_\tau^{\hat{\lambda}}$. Fatou's lemma implies $\mathbf{E}[M_\tau^{\hat{\lambda}}] \leq 1$. On the other hand,

$$\mathbf{E}[M_\tau^{\hat{\lambda}}] = \lim_{n \rightarrow \infty} \mathbf{E}[M_\tau^{\hat{\lambda}} \mathbf{1}_{\{\tau \leq n\}}] = \lim_{n \rightarrow \infty} (1 - \mathbf{E}[M_{n \wedge \tau}^{\hat{\lambda}} \mathbf{1}_{\{\tau > n\}}]). \tag{3.22}$$

It remains to prove that $\lim_{n \rightarrow \infty} \mathbf{E}[M_n^{\hat{\lambda}} \mathbf{1}_{\{\tau > n\}}] = 0$. Let $(\tilde{U}_i)_{i \geq 1}$ be i.i.d. with law $\tilde{\mathbf{P}}$ such that

$$\tilde{\mathbf{P}}(\tilde{U}_1 = x) = \frac{1}{\mathbf{E}[e^{-\hat{\lambda}|U_1|}]} e^{-\hat{\lambda}|x|} \mathbf{P}(U_1 = x), \quad x \in \mathbb{Z}.$$

We observe that

$$\mathbf{E}[M_n^{\hat{\lambda}} \mathbf{1}_{\{\tau > n\}}] = e^{\alpha n + \log \mathbf{E}[e^{-\hat{\lambda}|U_1|}] n} \tilde{\mathbf{P}}(\tau > n) = \tilde{\mathbf{P}}(\tau > n). \tag{3.23}$$

Under $\tilde{\mathbf{P}}$, the random walk increments $(\tilde{U}_i)_{i \geq 1}$ are symmetric and integrable. Thus, τ is finite $\tilde{\mathbf{P}}$ -a.s. and the right hand side in (3.23) converges to 0 as n tends to ∞ . We conclude that $\mathbf{E}[M_\tau^{\hat{\lambda}}] = 1$. \square

3.4 Scaling limit of the uniform 2-sided prudent walk

In this section we prove Theorems 3.1 and 3.2.

Proof of Theorems 3.1 and 3.2. Let \mathbf{P}^* be the law of the i.i.d. sequence of effective random walk excursions as in (3.13), and let $(\tilde{T}_i, \tilde{N}_i)_{i \in \mathbb{N}}$ and $\tilde{\gamma}_L$ be as introduced after (3.14). Then by the law of large numbers, as $L \rightarrow \infty$, almost surely we have $\frac{\tilde{\gamma}_L}{L} \rightarrow \frac{1}{\mathbf{E}^*[\tilde{T}_1]} > 0$, since \tilde{T}_1 has exponential tail by Remark 3.5. Let $\tilde{\tau}_k = \sum_{i=1}^k \tilde{T}_i$, which defines a renewal process. For any $t_0 < 1/\mathbf{E}^*[\tilde{T}_1]$, note that by the renewal theorem, cf. [5, Appendix A], the law of $(\tilde{T}_i, \tilde{N}_i)_{1 \leq i \leq t_0 L}$ conditioned on $L \in \tilde{\tau}$ is equivalent to its law under \mathbf{P}^* without conditioning, in fact their total variation distance tends to 0 as L tends to infinity since $L - \sum_{i=1}^{t_0 L} \tilde{T}_i \rightarrow \infty$ in probability. Therefore to identify the scaling limit of $(\pi_i)_{i=1}^{t_0 L}$ under $\mathbf{P}_{\text{unif}, L}^+$ by (3.16), it suffices to consider \mathbf{P}^* in place of $\mathbf{P}_{\text{unif}, L}^+$.

Recall that the 2-sided uniform prudent walk π is constructed by concatenating alternatingly eastward horizontal excursions and northward vertical excursions, where modulo rotation, the excursions have a one-to-one correspondence with the effective random walk excursions. Therefore if we let $X_n := (X_{n,1}, X_{n,2})$ be a random walk on \mathbb{Z}^2 with

$$X_{n,1} = \sum_{i=1}^n (\tilde{N}_{2i-1} - c(\tilde{T}_{2i-1} + \tilde{T}_{2i})), \quad X_{n,2} = \sum_{i=1}^n (\tilde{N}_{2i} - c(\tilde{T}_{2i-1} + \tilde{T}_{2i})), \quad \text{where } c = \frac{\mathbf{E}^*[\tilde{N}_1]}{2\mathbf{E}^*[\tilde{T}_1]}, \tag{3.24}$$

then $X_n = \pi_{\varphi(n)} - c\varphi(n)\vec{e}_1$, with $\varphi(n) = \sum_{i=1}^{2n} \tilde{T}_i$ playing the role of time change. By the strong law of large numbers, \mathbf{P}^* -a.s., we have

$$\left(\frac{1}{L}X_{tL}\right)_{t \geq 0} \rightarrow 0 \quad \text{and} \quad \left(\frac{\varphi(tL)}{L}\right)_{t \geq 0} \rightarrow (2t\mathbf{E}^*[\tilde{T}_1])_{t \geq 0}. \tag{3.25}$$

It is then easily seen that, with $I := \{\frac{1}{L} \sum_{i=1}^{2k} \tilde{T}_i : 1 \leq k \leq t_0L/2\}$, the rescaled path $\tilde{\pi}^L$ satisfies

$$\sup_{t \in I} |\tilde{\pi}_t^L - ct\vec{e}_1| = \sup_{t \in I} \left| \frac{1}{L}X_{\varphi^{-1}(tL)} \right| \rightarrow 0 \quad \mathbf{P}^*\text{-a.s. as } L \rightarrow \infty. \tag{3.26}$$

In fact (3.26) still holds if the supremum is taken over all $0 \leq t \leq \frac{1}{L} \sum_{i=1}^{t_0L} \tilde{T}_i$, since for the i -th excursion, the prudent path deviates from the end points of the excursion by at most \tilde{T}_i , which has exponential tail by Remark 3.5. It is then easily seen that

$$\frac{1}{\sqrt{L}} \max_{1 \leq i \leq L} \tilde{T}_i \rightarrow 0 \quad \mathbf{P}^*\text{-a.s. as } L \rightarrow \infty. \tag{3.27}$$

Therefore (3.26) holds with sup taken over $t \in [0, \tilde{t}_0]$, with $\tilde{t}_0 := \lim_{L \rightarrow \infty} \frac{1}{L} \sum_{i=1}^{t_0L} \tilde{T}_i = t_0\mathbf{E}^*[\tilde{T}_1] < 1$, and $(\tilde{\pi}_t^L)_{t \in [0, \tilde{t}_0]}$ converges in probability to $(ct\vec{e}_1)_{t \in [0, \tilde{t}_0]}$ under \mathbf{P}^* as well as $\mathbf{P}_{\text{unif}, L}^+$. We can now deduce (3.1) by letting $\tilde{t}_0 \uparrow 1$, using that modulo time reversal, translation and rotation, $(\pi_i)_{i=\gamma_L-\varepsilon L}^{\gamma_L}$ has the same law as $(\pi_i)_{i=1}^{\varepsilon L}$ under $\mathbf{P}_{\text{unif}, L}^+$, and hence is negligible in the scaling limit as $\varepsilon \downarrow 0$.

The proof of Theorem 3.2 is similar. By (3.27), it suffices to consider $\pi_t - ct\vec{e}_1$ along the sequence of times $(\varphi_n)_{n \in \mathbb{N}}$, which is a time change of $(X_n)_{n \in \mathbb{N}}$. It is clear that $(X_{tL}/\sqrt{L})_{t \geq 0}$ converges to a Brownian motion $(\tilde{B}_t)_{t \geq 0}$ with covariance matrix $\mathbf{E}[\tilde{B}_{1,i}\tilde{B}_{1,j}] = \mathbf{E}[X_{1,i}X_{1,j}]$. Undo the time change φ , which becomes asymptotically deterministic by (3.25), we find that under \mathbf{P}^* , hence also $\mathbf{P}_{\text{unif}, L}^+$,

$$\sqrt{L}(\tilde{\pi}_t^L - ct\vec{e}_1)_{t \in [0, \tilde{t}_0]} \Rightarrow (B_t)_{t \in [0, \tilde{t}_0]},$$

where B is a Brownian motion with covariance matrix

$$\mathbf{E}[B_{1,i}B_{1,j}] = \frac{\mathbf{E}[(2\tilde{N}_i\mathbf{E}^*[\tilde{T}_1] - \mathbf{E}^*[\tilde{N}_1](\tilde{T}_1 + \tilde{T}_2))(2\tilde{N}_j\mathbf{E}^*[\tilde{T}_1] - \mathbf{E}^*[\tilde{N}_1](\tilde{T}_1 + \tilde{T}_2))]}{8\mathbf{E}^*[\tilde{T}_1]^3}, \quad i, j = 1, 2. \tag{3.28}$$

Letting $\tilde{t}_0 \uparrow 1$ and applying the same reasoning as before then gives (3.2). \square

4 Uniform prudent walk

By symmetry, we may assume without loss of generality that the prudent walk starts with an east step, and the first vertical step is a north step. We will assume this from now on.

4.1 Decomposition of a prudent path into excursions in its range

We now decompose each prudent path $\pi \in \Omega_L$ into a sequence of excursions within its range (see Figure 2). We use the same decomposition as in [2, Section 2], which is slightly different from our decomposition for the 2-sided prudent path.

For every $t \leq L$, let \mathcal{A}_t (resp. \mathcal{B}_t) denote the projection of the range of π onto the x -axis (resp. y -axis), i.e.,

$$\mathcal{A}_t = \{\pi_{i,1} \in \mathbb{Z} : 0 \leq i \leq t\} \quad \text{and} \quad \mathcal{B}_t = \{\pi_{i,2} \in \mathbb{Z} : 0 \leq i \leq t\}. \tag{4.1}$$

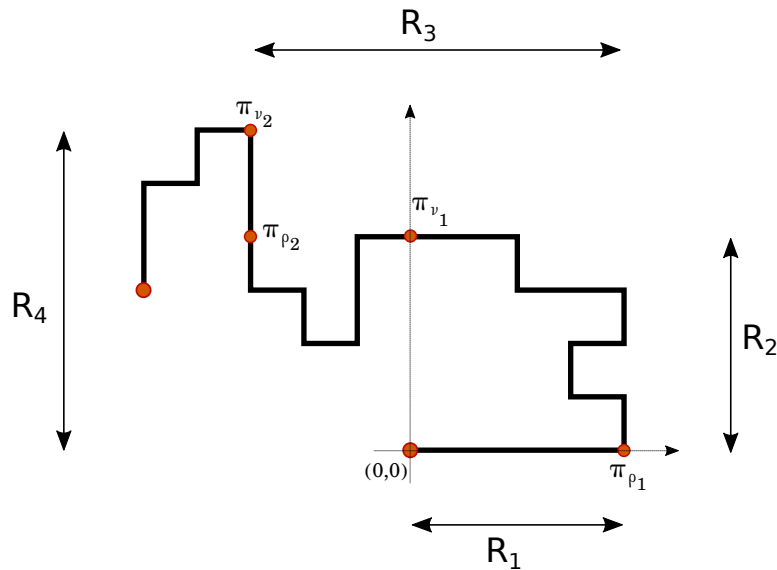

Figure 2: We decompose a path $\pi \in \Omega_L$ into a sequence of excursions. The i -th excursion is a horizontal excursion if i is odd, and vertical excursion if i is even. The 1-st excursion corresponds to the sub-path $\pi_{[0, \rho_1]}$, the 2-nd to the sub-path $\pi_{[\rho_1, v_1]}$ and so on. At the end of the i -th excursion, if i is odd (resp. if i is even) we set R_i to be the width (resp. the height) of the range. The last excursion is incomplete.

Let $\mathcal{W}_t = |\mathcal{A}_t|$ and $\mathcal{H}_t = |\mathcal{B}_t|$ denote respectively the width and height of the range $\pi_{[0,t]}$. Define $\mathcal{H}_0 = \mathcal{W}_0 = 1$, and set $\rho_0 = \nu_0 = 0$. For $k \geq 0$, define

$$\rho_{k+1} = \min\{t > \nu_k : \mathcal{H}_t > \mathcal{H}_{t-1}\} - 1, \quad \nu_{k+1} = \min\{t > \rho_{k+1} : \mathcal{W}_t > \mathcal{W}_{t-1}\} - 1. \quad (4.2)$$

We say that on each interval $[\rho_k, \nu_k]$ (resp. $[\nu_k, \rho_{k+1}]$) π performs a vertical (resp. horizontal) excursion in its range, and the path is monotone in the vertical (resp. horizontal) direction. Note that each excursion ends by exiting one of two sides of the smallest rectangle containing the range of π up to that time, and the excursion ends at a corner of this rectangle.

Let $\gamma_L(\pi)$ be the number of complete excursions contained in π , where the last excursion is considered complete if adding an extra horizontal or vertical step can make it complete. Let T_i denote the length of the i -th excursion, N_i its horizontal (resp. vertical) extension if it is a horizontal (resp. vertical) excursion, and let $\mathcal{E}_i = 1$ if the excursion crosses the range and let $\mathcal{E}_i = 0$ otherwise. More precisely, a horizontal excursion on the interval $[\nu_k, \rho_{k+1}]$ crosses the range if $|\pi_{\rho_{k+1}, 2} - \pi_{\nu_k, 2}| = \mathcal{H}_{\rho_{k+1}}$. We can thus associate with every $\pi \in \Omega_L$ the sequence $(T_i, N_i, \mathcal{E}_i)_{i=1}^{\gamma_L(\pi)}$. Note that the i -th excursion is a horizontal excursion if i is odd, and vertical excursion if i is even. For $i \in \mathbb{N}$, let R_{i-1} denote the width (resp. height) of the range of π before the start of the i -th excursion if it is a vertical (resp. horizontal) excursion. It can be seen that $R_i = R_{i-2} + N_i$ for $i \geq 1$, with $R_{-1} = R_0 = 0$.

4.2 Effective random walk excursion in a slab

The one-to-one correspondence in Section 3.2 between the excursion paths (which are partially directed) and the effective random walk paths can be extended to the current setting, except that now the effective random walk lies in a slab corresponding to the range of the path at the start of the excursion, and the excursion may end on either side

of the slab. As a consequence, we define a measure L_R on $\mathbb{N} \times \mathbb{N} \times \{0, 1\}$ by

$$\begin{aligned} L_R(t, n, 0) &= \mathbf{E} \left[e^{\log(\frac{3}{2})n - \lambda^* t} \mathbf{1}_{\{V_i \in \{0, \dots, R\} \forall i \leq n, V_n = 0, \sum_{i=1}^n |U_i| = t - n\}} \right], \\ L_R(t, n, 1) &= \mathbf{E} \left[e^{\log(\frac{3}{2})n - \lambda^* t} \mathbf{1}_{\{V_i \in \{0, \dots, R\} \forall i \leq n, V_n = R, \sum_{i=1}^n |U_i| = t - n\}} \right]. \end{aligned} \tag{4.3}$$

When $R = 0$, define $L_0(t, n, 1)$ as above and define $L_0(t, n, 0) = 0$. Let \widehat{L}_R be a variant of L_R that accounts for an incomplete excursion (cf. Figure 2), i.e.,

$$\widehat{L}_R(t, n) = \mathbf{E} \left[e^{\log(\frac{3}{2})n - \lambda^* t} \mathbf{1}_{\{V_i \in \{0, \dots, R\} \forall i \leq n, 0 < V_n < R, \sum_{i=1}^n |U_i| = t - n\}} \right], \tag{4.4}$$

where λ^* is as in Lemma 3.4. We also set $\widehat{L}_R(t) = \sum_{n \geq 1} \widehat{L}_R(t, n)$ and $\widehat{L}_R(0) = 1$.

Let $\alpha^* = \log(\frac{3}{2}) - \lambda^*$, and let $(t_i, n_i, \varepsilon_i) \in \mathbb{N}^2 \times \{0, 1\}$, $1 \leq i \leq r$, be such that $t_1 + \dots + t_r \leq L$ and $n_i \leq t_i$. Let $\Omega_L((t_i, n_i, \varepsilon_i)_{i=1}^r)$ be the set of prudent paths containing r complete excursions, with $(T_i, N_i, \mathcal{E}_i)_{i=1}^r = (t_i, n_i, \varepsilon_i)_{i=1}^r$, and recall $(R_{i-1})_{i \in \mathbb{N}}$ from the end of Section 4.1. Reasoning as for (3.14), we then have

$$\begin{aligned} & \frac{1}{2L} |\Omega_L((t_i, n_i, \varepsilon_i)_{i=1}^r)| e^{-\lambda^* L} \\ &= \prod_{i=1}^r \mathbf{E} \left[e^{\alpha^* n_i - \lambda^* (t_i - n_i)} \mathbf{1}_{\{V_i \in [0, R_{i-1}] \forall i \leq n_i, V_{n_i} = \varepsilon_i R_{i-1}, n_i + \sum_{j=1}^{n_i} |U_j| = t_i\}} \right] \\ & \quad \times \widehat{L}_{R_r}(L - (t_1 + \dots + t_r)) \\ &= \left[\prod_{i=1}^r L_{R_{i-1}}(t_i, n_i, \varepsilon_i) \right] \widehat{L}_{R_r}(L - (t_1 + \dots + t_r)), \end{aligned} \tag{4.5}$$

where $\widehat{L}_{R_r}(L - (t_1 + \dots + t_r))$ accounts for the last incomplete excursion in π .

4.3 Representation of the law of a uniform prudent walk

We now show how to represent the law of the uniform prudent walk in terms of the excursions of the effective random walk V .

For $R \in \mathbb{N}$, let \mathcal{V}_R be the set of effective random walk paths in a slab of width R and ending at either 0 or R . Namely,

$$\mathcal{V}_R := \bigcup_{N \geq 1} \left[\mathcal{V}_{N,R}^1 \cup \mathcal{V}_{N,R}^0 \right], \tag{4.6}$$

where for $a = 0, 1$,

$$\mathcal{V}_{N,R}^a := \left\{ (V_i)_{i=0}^N : V_0 = 0, V_i \in \{0, \dots, R\} \forall i \in \{0, \dots, N\}, V_N = aR \right\}. \tag{4.7}$$

Recall the effective random walk excursion measure \mathbf{P}^* from (3.13). We will define a probability law \mathbf{P}_R^* on \mathcal{V}_R by sampling a path under \mathbf{P}^* and truncating it if it passes above $R + 1$. More precisely, define the truncation $T_R : \mathcal{V}_\infty \mapsto \mathcal{V}_R$ as follows. Given $V := (V_i)_{i=0}^N \in \mathcal{V}_\infty$, let $T_R V := V$ if $V_i \leq R$ for every $i \leq N$. Otherwise, let $\tau_R := \inf\{i \geq 1 : V_i \geq R + 1\}$ and set

$$(T_R V)_i = V_i \quad \text{for } i \leq \tau_R - 1 \text{ and } (T_R V)_{\tau_R} = R. \tag{4.8}$$

Then define \mathbf{P}_R^* as the image measure of \mathbf{P}^* under T_R . For each trajectory $V \in \mathcal{V}_R$, we associate (T, N, \mathcal{E}) such that N is the number of increments $(U_i)_{i=1}^N$ of V , $T = N + \sum_{i=1}^N |U_i|$, and $\mathcal{E} = 1$ if $V_N = R$ and $\mathcal{E} = 0$ if $V_N = 0$ (if $R = 0$, set $\mathcal{E} = 1$). Let L_R^*

denote the law of (T, N, \mathcal{E}) when V is sampled from \mathbf{P}_R^* , and we observe that L_R^* and L_R (cf. (4.3)) coincide when $\varepsilon = 0$, i.e.,

$$L_R(t, n, 0) = L_R^*(t, n, 0), \quad (t, n) \in \mathbb{N} \times \mathbb{N}. \tag{4.9}$$

Let $(\tilde{V}^{(i)})_{i \geq 1}$ be an i.i.d. sequence of effective walk excursions with law \mathbf{P}^* , and for each $i \in \mathbb{N}$, let $(\tilde{T}_i, \tilde{N}_i)$ denote the total length and the number of increments of $\tilde{V}^{(i)}$. We now construct a sequence $(T_i, N_i, \mathcal{E}_i)_{i \geq 1}$ from $(\tilde{V}^{(i)})_{i \geq 1}$ inductively, using the truncation map T_R . First set $R_{-1} = R_0 := 0$. For each $i \geq 1$, set

$$V^{(i)} = T_{R_{i-1}} \tilde{V}^{(i)}, \quad (N_i, T_i, \mathcal{E}_i) = (N, T, \mathcal{E})(V^{(i)}), \quad \text{and} \quad R_i = R_{i-2} + N_i. \tag{4.10}$$

where $(N, T, \mathcal{E})(V^{(i)})$ is the triple (N, T, \mathcal{E}) associated with $V^{(i)} \in \mathcal{V}_{R_{i-1}}$. For every $i \geq 1$, we have $N_i \leq \tilde{N}_i$ and $T_i \leq \tilde{T}_i$, and conditioned on $(T_j, N_j, \mathcal{E}_j)_{j=1}^{i-1}$, the law of $(N_i, T_i, \mathcal{E}_i)$ is $\mathbf{P}_{R_{i-1}}^*$. Note that the excursion decomposition of a prudent path in Section 4.1 gives exactly a sequence of excursions of the form $(T_R \tilde{V}^{(i)})_{i \geq 1}$.

For a set of prudent paths $A \subset \Omega_L$ depending only on $(T_i, N_i, \mathcal{E}_i)_{i=1}^{\gamma_L}(\pi)$, where

$$\gamma_L = \min\{i \geq 1: T_1 + \dots + T_i > L\} - 1, \tag{4.11}$$

let $(t_i, n_i, \varepsilon_i)_{i=1}^r \sim A$ denote compatibility with A . By (4.5), we then have

$$\begin{aligned} \frac{1}{2^L} |A| e^{-\lambda^* L} &= \sum_{(t_i, n_i, \varepsilon_i)_{i=1}^r \sim A} \left[\prod_{i=1}^r L_{R_{i-1}}(t_i, n_i, \varepsilon_i) \right] \widehat{L}_{R_r}(L - (t_1 + \dots + t_r)) \\ &= \mathbf{E}^* \left[\mathbf{1}_{\{(T_i, N_i, \mathcal{E}_i)_{i=1}^{\gamma_L} \sim A\}} \prod_{i=1}^{\gamma_L} \frac{L_{R_{i-1}}(T_i, N_i, \mathcal{E}_i)}{L_{R_{i-1}}^*(T_i, N_i, \mathcal{E}_i)} \cdot \frac{\widehat{L}_{R_{\gamma_L}}(L - (T_1 + \dots + T_{\gamma_L}))}{\mathbf{P}_{R_{\gamma_L}}^*(T > L - (T_1 + \dots + T_{\gamma_L}))} \right], \end{aligned} \tag{4.12}$$

where \mathbf{E}^* is expectation over the i.i.d. excursions $(\tilde{V}^{(i)})_{i \geq 1}$, and hence $(T_i, N_i, \mathcal{E}_i)_{i \geq 1}$.

We conclude this section with two technical lemmas needed to control the ratios inside the expectation in (4.12). For ease of notation, let us denote

$$L_R(t, \varepsilon) := \sum_{n \geq 1} L_R(t, n, \varepsilon) \quad \text{and} \quad L_R(t) := L_R(t, 0) + L_R(t, 1). \tag{4.13}$$

Lemma 4.1. *There exists $C > 0$ such that*

$$\frac{L_R(t)}{L_R^*(t)} \leq C t \mathbf{1}_{\{t \geq R\}} + \mathbf{1}_{\{t < R\}} \quad \text{for all } t \in \mathbb{N}. \tag{4.14}$$

Proof. First, observe that for $t < R$, a path of length t cannot reach level R . Therefore, $L_R(t, n, 1) = L_R^*(t, n, 1) = 0$ and $L_R(t, n, 0) = L_R^*(t, n, 0)$. It only remains to consider $t \geq R$, and it suffices to show that $L_R(t, 1) \leq C t L_R(t, 0) = C t L_R^*(t)$. For simplicity we only consider the case $R \in 2\mathbb{N}$, but the case $R \in 2\mathbb{N} + 1$ can be treated in a similar manner. Let

$$\mathcal{B}_{n,t}^R := \left\{ (V_i)_{i=0}^n: V_0 = 0, V_i \in \{0, \dots, R\} \forall i \in \{0, \dots, n\}, V_n = R, \sum_{i=1}^n |U_i| = t - n \right\}, \tag{4.15}$$

$$\mathcal{A}_{n,t}^R := \left\{ (V_i)_{i=0}^n: V_0 = 0, V_i \in \{0, \dots, R\} \forall i \in \{0, \dots, n\}, V_n = 0, \sum_{i=1}^n |U_i| = t - n \right\}. \tag{4.16}$$

We define a map $G_{n,t}^R: \mathcal{B}_{n,t}^R \mapsto \mathcal{A}_{n,t}^R \cup \mathcal{A}_{n+2,t}^R$ as follows. For $V \in \mathcal{B}_{n,t}^R$, let $\tau_{R/2} := \min\{i \geq 1: V_i \geq R/2\}$. We distinguish between two cases (see Figure 3):

1. If $V_{\tau_{R/2}} = R/2$, then define $G_{n,t}^R(V)$ by simply reflecting V across $R/2$ from $\tau_{R/2}$ onward, i.e., $G_{n,t}^R(V)_i = V_i$ for $i \leq \tau_{R/2}$ and $G_{n,t}^R(V)_i = R - V_i$ for $i \in \{\tau_{R/2}, \dots, n\}$. Then, $G_{n,t}^R(V) \in \mathcal{A}_{n,t}^R$.
2. If $V_{\tau_{R/2}} = R/2 + y$ with $y \in \{1, \dots, \frac{R}{2}\}$, then let $G_{n,t}^R(V)_i = V_i$ for $i \leq \tau_{R/2} - 1$, $G_{n,t}^R(V)_{\tau_{R/2}} = \frac{R}{2} - 1$, $G_{n,t}^R(V)_i = R - V_{i-1}$ for $i \in \{\tau_{R/2} + 1, \dots, n + 1\}$ and $G_{n,t}^R(V)_{n+2} := 0$. Then, $G_{n,t}^R(V) \in \mathcal{A}_{n+2,t}^R$.

Note that under $G_{n,t}^R$, every $V \in G_{n,t}^R(\mathcal{B}_{n,t}^R) \cap \mathcal{A}_{n,t}^R$ has a unique pre-image in $\mathcal{B}_{n,t}^R$, and every $V \in G_{n,t}^R(\mathcal{B}_{n,t}^R) \cap \mathcal{A}_{n+2,t}^R$ has at most $n \leq t$ pre-images in $\mathcal{B}_{n,t}^R$, one for each time that V is at level $\frac{R}{2} - 1$. Finally, we note that in the second case, $G_{n,t}^R(V)$ has two fewer vertical steps and two more horizontal steps than V . This allows us to write

$$\begin{aligned}
 L_R(t, 1) &= \sum_{n=1}^t \mathbf{E} \left[e^{\log(\frac{3}{2})n - \lambda^* t} \mathbf{1}_{\mathcal{B}_{n,t}^R}(V) \right] \\
 &\leq \sum_{n=1}^t \mathbf{E} \left[e^{\log(\frac{3}{2})n - \lambda^* t} \mathbf{1}_{\mathcal{A}_{n,t}^R}(V) \right] + t \mathbf{E} \left[e^{\log(\frac{3}{2})(n+2) - \lambda^* t} \mathbf{1}_{\mathcal{A}_{n+2,t}^R}(V) \right].
 \end{aligned}
 \tag{4.17}$$

Observe that the r.h.s. in (4.17) is less than $\sum_{n=1}^t L_R(n, t, 0) + tL_R(n + 2, t, 0)$, which implies

$$L_R(t, 1) \leq 2tL_R(t, 0). \tag{4.18}$$

This concludes the proof of the lemma. \square

To bound the last ratio in (4.12), we will bound $\widehat{L}_R(t)/\mathbf{P}_R^*(T \geq t)$, which arises from the last incomplete excursion in the excursion decomposition. Recall that $\widehat{L}_R(0) := 1 = \mathbf{P}_R^*(T > 0)$.

Lemma 4.2. *There exists $C > 0$ such that*

$$\frac{\widehat{L}_R(t)}{\mathbf{P}_R^*(T > t)} \leq CRt^2 \quad \text{for all } R, t \in \mathbb{N}. \tag{4.19}$$

Proof. Recall $\widehat{L}_R(t)$ from (4.4). It suffices to show that there exists $C > 0$ such that

$$\widehat{L}_R(t) \leq CRt^2 L_R(t + 2, 0), \tag{4.20}$$

since

$$\mathbf{P}_R^*(T > t) = \sum_{j>t} L_R^*(j) \geq \sum_{j>t} L_R^*(j, 0) = \sum_{j>t} L_R(j, 0) \geq L_R(t + 2, 0).$$

For $x \in \{1, \dots, R - 1\}$ and $n \leq t$, we consider the set of effective random walk trajectories

$$\mathcal{D}_{n,t}^{R,x} = \left\{ (V_i)_{i=0}^n : V_0 = 0, V_i \in \{0, \dots, R\} \forall i \in \{0, \dots, n\}, V_n = x, \sum_{i=1}^n |U_i| = t - n \right\}. \tag{4.21}$$

For simplicity, we assume that x is even, but the case x odd can be treated similarly. Let

$$\sigma_{x/2} := \max\{i \geq 0 : V_i < \frac{x}{2}\} \quad \text{and} \quad \tilde{\sigma}_x := \min\{i \geq \sigma_{x/2} + 1 : V_i \geq x\}. \tag{4.22}$$

We define a map $H_{n,t}^{R,x} : \mathcal{D}_{n,t}^{R,x} \rightarrow \mathcal{A}_{n+2,t+2}^R$ (cf. (4.16)) as follows. Let $V \in \mathcal{D}_{n,t}^{R,x}$. We distinguish between four cases:

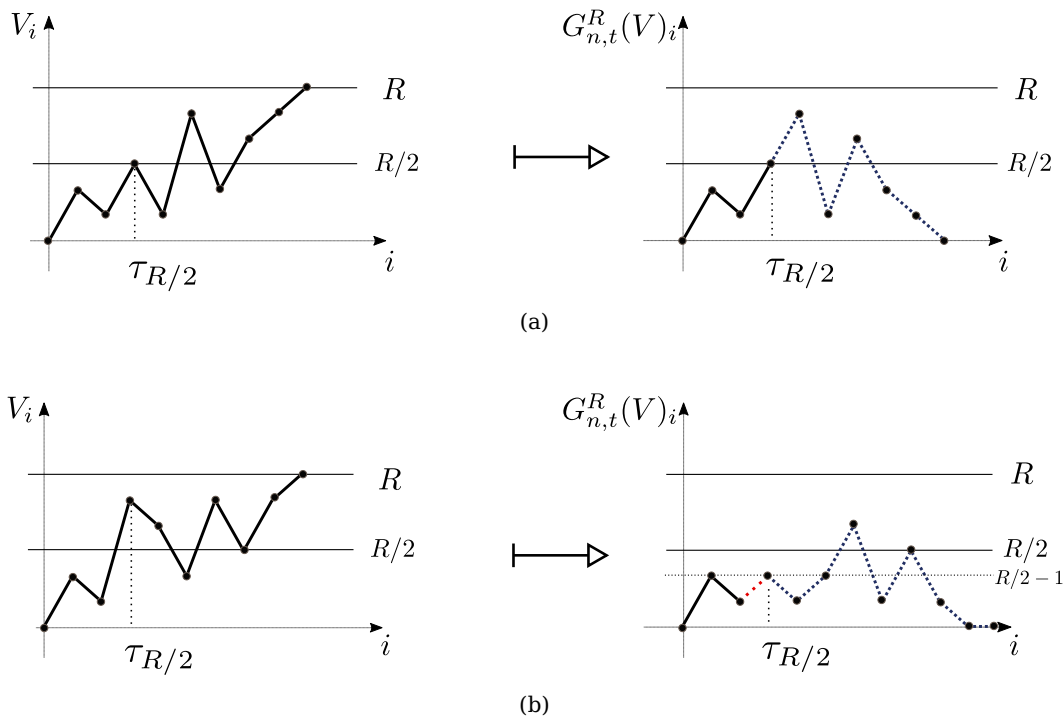

Figure 3: The transformation $G_{n,t}^R(V)$. We let $\tau_{R/2} := \min\{i \geq 1 : V_i \geq R/2\}$. In (a) we draw the case in which $V_{\tau_{R/2}} = R/2$. In this case we define $G_{n,t}^R(V)$ by simply reflecting V across $R/2$ from $\tau_{R/2}$ onward (in blue, dotted). In (b) we draw the case in which $V_{\tau_{R/2}} > R/2$. In this second case we let $G_{n,t}^R(V)_{\tau_{R/2}} = \frac{R}{2} - 1$ (in red, dotted) and we concatenate the reflection of V across $R/2$ from $\tau_{R/2}$ onward. We add a final point $G_{n,t}^R(V)_{n+2} := 0$ (in blue, dotted).

1. $V_{\sigma_{x/2+1}} > x/2$ and $V_{\tilde{\sigma}_x} > x$,
2. $V_{\sigma_{x/2+1}} > x/2$ and $V_{\tilde{\sigma}_x} = x$,
3. $V_{\sigma_{x/2+1}} = x/2$ and $V_{\tilde{\sigma}_x} > x$,
4. $V_{\sigma_{x/2+1}} = x/2$ and $V_{\tilde{\sigma}_x} = x$.

We will treat case 1 only, where $H_{n,t}^{R,x}$ maps V to a path in $\mathcal{A}_{n+2,t+2}^R$ (see Figure 4). Cases 2–4 are similar and even simpler, and to ensure that $H_{n,t}^{R,x}(V) \in \mathcal{A}_{n+2,t+2}^R$, we can add extra horizontal steps if needed. Roughly speaking, under $H_{n,t}^{R,x}$, the piece of V on the interval $[\tilde{\sigma}_x, n]$ is lowered by $x/2$ and inserted at time $\sigma_{x/2} + 2$, while the piece of V on the interval $[\sigma_{x/2} + 1, \tilde{\sigma}_x - 1]$ is reflected across $x/2$ and reattached at the end. More precisely, set

$$\begin{aligned}
 H_{n,t}^{R,x}(V)_i &:= V_i \quad \text{for } i \leq \sigma_{x/2}, \\
 H_{n,t}^{R,x}(V)_{\sigma_{x/2+1}} &:= x/2, \\
 H_{n,t}^{R,x}(V)_{\sigma_{x/2+1+i}} &:= V_{\tilde{\sigma}_x+i-1} - x/2 \quad \text{for } i = 1, \dots, n+1 - \tilde{\sigma}_x, \\
 H_{n,t}^{R,x}(V)_{n+2-(\tilde{\sigma}_x-\sigma_{x/2})+i} &:= x - V_{\sigma_{x/2}+i} \quad \text{for } i = 1, \dots, \tilde{\sigma}_x - \sigma_{x/2} - 1, \\
 H_{n,t}^{R,x}(V)_{n+2} &:= 0.
 \end{aligned}$$

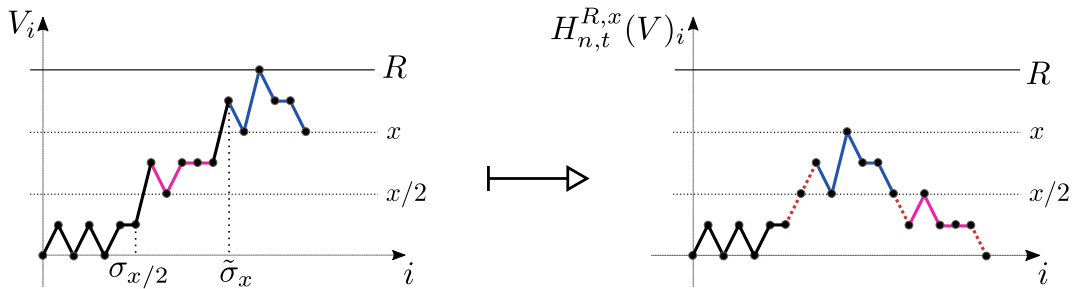

Figure 4: The transformation $H_{n,t}^{R,x}(V)$: We fix $x \leq R$ even and we consider a path V ending at $V_n = x$. We let $\sigma_{x/2} := \max\{i \geq 0: V_i < \frac{x}{2}\}$ and $\tilde{\sigma}_x := \min\{i \geq \sigma_{x/2} + 1: V_i \geq x\}$. In the figure we draw the transformation $H_{n,t}^{R,x}(V)$ when $V_{\sigma_{x/2}+1} > x/2$ and $V_{\tilde{\sigma}_x} > x$. In this case we define $H_{n,t}^{R,x}(V)_{\sigma_{x/2}+1} := x/2$. Then we take the piece of V on the interval $[\tilde{\sigma}_x, n]$ lowered by $x/2$ and we insert it at time $\sigma_{x/2} + 2$ (blue). Finally the piece of V on the interval $[\sigma_{x/2} + 1, \tilde{\sigma}_x - 1]$ is reflected across $x/2$ and reattached at the end (violet). We add a final point $H_{n,t}^{R,x}(V)_{n+2} := 0$.

We note that the sum of absolute increments of $H_{n,t}^{R,x}(V)$ equals that of V , and $H_{n,t}^{R,x}(V)$ is confined to $[0, R]$. Therefore $H_{n,t}^{R,x}(V) \in \mathcal{A}_{n+2,t+2}^R$. It remains to bound the number of pre-images of every $V \in \mathcal{A}_{n+2,t+2}^R \cap H_{n,t}^{R,x}(\mathcal{D}_{n,t}^{R,x})$ under $H_{n,t}^{R,x}$. Note that to undo $H_{n,t}^{R,x}(V)$, we only need to find the two times $\sigma_{x/2} + 2$ and $\sigma_{x/2} + n + 2 - \tilde{\sigma}_x$ at which the original segments of V are glued together and $H_{n,t}^{R,x}(V)_i = 0$. Since there are at most $n^2 \leq t^2$ such choices, and combined with similar estimates for cases 2–4, we have

$$\begin{aligned} \widehat{L}_R(t, n) &= \sum_{x=1}^{R-1} \mathbf{E} \left[e^{\log(\frac{3}{2})n - \lambda^* t} \mathbf{1}_{\mathcal{D}_{n,t}^{R,x}(V)} \right] & (4.23) \\ &\leq 4(R-1) t^2 \left(3^2 e^{-2 \log(\frac{3}{2}) + 2\lambda^*} \mathbf{E} \left[e^{\log(\frac{3}{2})(n+2) - \lambda^*(t+2)} \mathbf{1}_{\mathcal{A}_{n+2,t+2}^R(V)} \right] \right) \\ &\leq CR t^2 L_R(t+2, n+2, 0), \end{aligned}$$

which establishes (4.20) and hence the lemma. □

As a corollary of Lemma 4.2, we have the following bound on the last ratio in (4.12):

$$\frac{\widehat{L}_{R\gamma_L}(L - (T_1 + \dots + T_{\gamma_L}))}{\mathbf{P}_{R\gamma_L}^*(T > L - (T_1 + \dots + T_{\gamma_L}))} \leq CL(L - (T_1 + \dots + T_{\gamma_L}))^2. \quad (4.24)$$

5 Proof of Theorems 2.2 and 2.3

We will use the excursion decomposition developed in Section 4, in particular, the representation in (4.12). First we show that for large L , a uniform prudent walk typically crosses its range at most $\log L$ times. Namely,

Lemma 5.1. *There exists $\delta > 0$ such that*

$$\lim_{L \rightarrow \infty} \mathbf{P}_{\text{unif},L}[\exists i \in \{\delta \log L, \dots, \gamma_L(\pi)\}: \mathcal{E}_i(\pi) = 1] = 0. \quad (5.1)$$

Then we show that the total length of the first $\log L$ excursions grows less than a power of $\log L$.

Lemma 5.2. *For every $\delta > 0$, there exists $\kappa > 0$ such that*

$$\lim_{L \rightarrow \infty} \mathbf{P}_{\text{unif},L}[T_1(\pi) + \dots + T_{\delta \log L}(\pi) \geq \kappa (\log L)^2] = 0. \quad (5.2)$$

Finally, we show that the last incomplete excursion of the walk typically has length at most $\log L$.

Lemma 5.3. *There exists $\alpha > 0$ such that*

$$\lim_{L \rightarrow \infty} \mathbf{P}_{\text{unif},L} [L - (T_1 + \dots + T_{\gamma_L}) \geq \alpha \log L] = 0. \tag{5.3}$$

We prove Theorem 2.2 next using Lemmas 5.1–5.3, whose proof are postponed to Sections 5.2–5.4.

5.1 Proof of Theorems 2.2 and 2.3

Let $\delta, \kappa, \alpha > 0$, and we define $\mathcal{G}_L \subset \Omega_L$ by

$$\mathcal{G}_L := \left\{ \mathcal{E}_i = 0 \forall i \in \{\delta \log L, \dots, \gamma_L\}, T_1 + \dots + T_{\delta \log L} \leq \kappa(\log L)^2, \right. \\ \left. L - (T_1 + \dots + T_{\gamma_L}) \leq \alpha \log L \right\}.$$

By Lemmas 5.1–5.3, we can choose δ, κ and α such that $\lim_{L \rightarrow \infty} \mathbf{P}_{\text{unif},L}(\mathcal{G}_L) = 1$.

We introduce a little more notation. Let $\mathcal{O} := \{\text{NE}, \text{NW}, \text{SE}, \text{SW}\}$ be the set of possible directions of a 2-sided prudent path. For $o \in \mathcal{O}$ let Ω_L^o be the set of L -step 2-sided path with orientation o (e.g. $\Omega_L^{\text{NE}} = \Omega_L^+$). Pick $\pi \in \Omega_L$ and recall that the endpoint of each excursion of π lies at one of the 4 corners (indexed in \mathcal{O}) of the smallest rectangle containing the range of π up to that endpoint. Thus, for $\pi \in \mathcal{G}_L$, we denote by $\vartheta(\pi) \in \mathcal{O}$ the corner at which the endpoint of the $\delta \log L$ -th excursion lies.

For a path $\pi \in \mathcal{G}_L$, let $\sigma_1 := T_1 + \dots + T_{\delta \log L}$ be the length of the first $\delta \log L$ excursions, and let $\sigma_2 := L - (T_1 + \dots + T_{\gamma_L})$ be the length of the last incomplete excursion. Note that $(\pi_i)_{i=\sigma_1}^{L-\sigma_2}$ is a 2-sided prudent path of orientation $\vartheta(\pi)$ because $\mathcal{E}_i = 0$ for $\delta \log L < i \leq \gamma_L(\pi)$. Therefore, we can safely enlarge a bit \mathcal{G}_L into

$$\tilde{\mathcal{G}}_L := \left\{ (\pi_i)_{i=\sigma_1}^{L-\sigma_2} \in \Omega_{L-\sigma_1-\sigma_2}^{\vartheta(\pi)}, T_1 + \dots + T_{\delta \log L} \leq \kappa(\log L)^2, L - (T_1 + \dots + T_{\gamma_L}) \leq \alpha \log L \right\}.$$

Note that conditioned on $\pi \in \tilde{\mathcal{G}}_L$, $\sigma_1(\pi) = m$, $\sigma_2(\pi) = n$, and $\vartheta(\pi) = o$, the law of $(\pi_i)_{i=m}^{L-n}$ under $\mathbf{P}_{\text{unif},L}$ (modulo translation and rotation) is exactly that of a uniform 2-sided prudent walk with total length $L - m - n$, for which we have proved the law of large numbers in Theorem 3.1 and the invariance principle in Theorem 3.2. Since $\mathbf{P}_{\text{unif},L}(\tilde{\mathcal{G}}_L) \rightarrow 1$, we only need to consider $m \leq \kappa(\log L)^2$ and $n \leq \alpha \log L$. Since $m/\sqrt{L}, n/\sqrt{L}$ tend to 0 uniformly as L tends to infinity, $(\pi_i)_{i=1}^m$ and $(\pi_i)_{i=L-n}^L$ are negligible in the scaling limit, and hence Theorems 2.2 and 2.3 follow from their counterparts for the uniform 2-sided prudent walk, with the direction o distributed uniformly in \mathcal{O} by symmetry. \square

5.2 Proof of Lemma 5.1

Let $M = M(L)$ be an increasing function of L that will be specified later. We set

$$\alpha_L := \frac{\mathbf{P}_{\text{unif},L}(\exists i \in [M, \gamma_L] \text{ s.t. } \mathcal{E}_i(\pi) = 1)}{|\Omega_L|} = \frac{|\{\pi \in \Omega_L : \exists i \in [M, \gamma_L] \text{ s.t. } \mathcal{E}_i(\pi) = 1\}|}{|\Omega_L|}. \tag{5.4}$$

Multiply both the numerator and denominator by $2^{-L} e^{-\lambda^* L}$, we can then apply (4.12) together with (4.24) to obtain

$$\begin{aligned} \alpha_L &\leq CL^3 \frac{\sum_{j=M}^L \mathbf{E}^* \left[\mathbf{1}_{\{\mathcal{E}_j=1\}} \prod_{i=1}^{\gamma_L} \frac{L_{R_{i-1}}(T_i, N_i, \mathcal{E}_i)}{L_{R_{i-1}}^*(T_i, N_i, \mathcal{E}_i)} \right]}{\mathbf{E}^* \left[\prod_{i=1}^{\gamma_L} \frac{L_{R_{i-1}}(T_i, N_i, \mathcal{E}_i)}{L_{R_{i-1}}^*(T_i, N_i, \mathcal{E}_i)} \mathbf{1}_{\{T_1+\dots+T_{\gamma_L}=L\}} \right]} \\ &\leq CL^3 \frac{\sum_{j \geq M} \mathbf{E}^* \left[\mathbf{1}_{\{T_j \geq \frac{j}{2}\}} \prod_{i=1}^{\gamma_L} \frac{L_{R_{i-1}}(T_i, N_i, \mathcal{E}_i)}{L_{R_{i-1}}^*(T_i, N_i, \mathcal{E}_i)} \right]}{\mathbf{E}^* \left[\prod_{i=1}^{\gamma_L} \frac{L_{R_{i-1}}(T_i, N_i, \mathcal{E}_i)}{L_{R_{i-1}}^*(T_i, N_i, \mathcal{E}_i)} \mathbf{1}_{\{T_1+\dots+T_{\gamma_L}=L\}} \right]} := CL^3 \frac{\Psi_1(L, M)}{D_L}, \end{aligned} \quad (5.5)$$

where we used that $\mathcal{E}_i = 1$ only if $T_i \geq 1 + R_{i-1}$, and $R_i \geq \frac{i-1}{2}$ for every $i \in \mathbb{N}$ (cf. Section 4.1). Lemma 5.1 then follows immediately from (5.5) and Claims 5.4 and 5.5 below.

Claim 5.4. *There exist $c_1, c_2 > 0$ such that $\Psi_1(L, M) \leq c_1 e^{-c_2 M}$ for every $M \in \mathbb{N}$ and $L \geq M$.*

Claim 5.5. *There exists $c_3 > 0$ such that $D_L \geq c_3$ for every $L \in \mathbb{N}$.*

Proof of Claim 5.4. Recall from Section 4.3 how $(T_i, N_i, \mathcal{E}_i)_{i \geq 1}$ is constructed from the i.i.d. sequence $(\tilde{V}_i, \tilde{T}_i, \tilde{N}_i)_{i \geq 1}$ with law \mathbf{P}^* , with $\tilde{T}_i \geq T_i \forall i \in \mathbb{N}$. We first state and prove a key lemma.

Lemma 5.6. *Let $L \in \mathbb{N}$, and let $\Phi : \mathbb{R}_+^L \rightarrow \mathbb{R}_+$ be any function that is non-decreasing in each of its L arguments. Then there exists $c > 0$ independent of L and Φ , such that*

$$\mathbf{E}^* \left[\Phi(T_1, \dots, T_L) \prod_{i=1}^{\gamma_L} \frac{L_{R_{i-1}}(T_i, N_i, \mathcal{E}_i)}{L_{R_{i-1}}^*(T_i, N_i, \mathcal{E}_i)} \right] \leq \mathbf{E}^* \left[\Phi(\tilde{T}_1, \dots, \tilde{T}_L) \prod_{i=1}^L (1 + c\tilde{T}_i \mathbf{1}_{\{\tilde{T}_i \geq \frac{i-1}{2}\}}) \right]. \quad (5.6)$$

Proof. For $n \in \mathbb{N}$, let \mathcal{F}_n be the σ -algebra generated by $(\tilde{T}_i, T_i, N_i, \mathcal{E}_i)_{i \leq n}$. For ease of notation, let A_L denote the l.h.s. of (5.6). Note that

$$A_L \leq \mathbf{E}^* \left[\Phi(T_1, \dots, T_L) \prod_{i=1}^L \max \left\{ \frac{L_{R_{i-1}}(T_i, N_i, \mathcal{E}_i)}{L_{R_{i-1}}^*(T_i, N_i, \mathcal{E}_i)}, 1 \right\} \right] \quad (5.7)$$

$$= \mathbf{E}^* \left[\prod_{i=1}^{L-1} \max \left\{ \frac{L_{R_{i-1}}(T_i, N_i, \mathcal{E}_i)}{L_{R_{i-1}}^*(T_i, N_i, \mathcal{E}_i)}, 1 \right\} H_L \right], \quad (5.8)$$

with

$$\begin{aligned} H_L &:= \mathbf{E}^* \left[\Phi(T_1, \dots, T_L) \max \left\{ \frac{L_{R_{L-1}}(T_L, N_L, \mathcal{E}_L)}{L_{R_{L-1}}^*(T_L, N_L, \mathcal{E}_L)}, 1 \right\} \middle| \mathcal{F}_{L-1} \right] \\ &= \sum_t \Phi(T_1, \dots, T_{L-1}, t) \sum_{n \leq t} \sum_{\varepsilon=0,1} \max \{ L_{R_{L-1}}(t, n, \varepsilon), L_{R_{L-1}}^*(t, n, \varepsilon) \}. \end{aligned} \quad (5.9)$$

When $t < R_{L-1}$, we have $L_{R_{L-1}}(t, n, 1) = L_{R_{L-1}}^*(t, n, 1) = 0$, and $L_{R_{L-1}}(t, n, 0) = L_{R_{L-1}}^*(t, n, 0)$ by (4.9), so that

$$\sum_{n \leq t} \sum_{\varepsilon=0,1} \max \{ L_{R_{L-1}}(t, n, \varepsilon), L_{R_{L-1}}^*(t, n, \varepsilon) \} = L_{R_{L-1}}^*(t). \quad (5.10)$$

When $t \geq R_{L-1}$, we have

$$\begin{aligned} &\sum_{n \leq t} \sum_{\varepsilon=0,1} \max \{ L_{R_{L-1}}(t, n, \varepsilon), L_{R_{L-1}}^*(t, n, \varepsilon) \} \\ &\leq \sum_{n \leq t} \sum_{\varepsilon=0,1} (L_{R_{L-1}}(t, n, \varepsilon) + L_{R_{L-1}}^*(t, n, \varepsilon)) = L_{R_{L-1}}(t) + L_{R_{L-1}}^*(t) \leq (1 + ct)L_{R_{L-1}}^*(t), \end{aligned} \quad (5.11)$$

where we applied Lemma 4.1. Therefore we have

$$\begin{aligned}
 H_L &\leq \sum_t \Phi(T_1, \dots, T_{L-1}, t) (1 + ct \mathbf{1}_{\{t \geq R_{L-1}\}}) L_{R_{L-1}}^*(t), \\
 &= \mathbf{E}^* [\Phi(T_1, \dots, T_{L-1}, T_L) (1 + cT_L \mathbf{1}_{\{T_L \geq R_{L-1}\}}) \mid \mathcal{F}_{L-1}].
 \end{aligned}
 \tag{5.12}$$

Since $R_{L-1} \geq \frac{L-1}{2}$ and $\tilde{T}_L \geq T_L$, we can replace R_{L-1} by $\frac{L-1}{2}$ and T_L by \tilde{T}_L in the r.h.s. of (5.12). Moreover, note that \tilde{T}_L does not depend on R_{L-1} , and hence we can plug (5.12) into (5.7) to obtain

$$A_L \leq \mathbf{E}^* \left[\left(\prod_{i=1}^{L-1} \max \left\{ \frac{L_{R_{i-1}}(T_i, N_i, \mathcal{E}_i)}{L_{R_{i-1}}^*(T_i, N_i, \mathcal{E}_i)}, 1 \right\} \right) \Phi(T_1, \dots, T_{L-1}, \tilde{T}_L) (1 + c\tilde{T}_L \mathbf{1}_{\{\tilde{T}_L \geq \frac{L-1}{2}\}}) \right].$$

We can now iterate the argument to deduce (5.6). □

To prove Claim 5.4, we now apply Lemma 5.6 with $\Phi(t_1, \dots, t_L) = \mathbf{1}_{\{t_j \geq \frac{j}{2}\}}$ for $j \geq M$ to obtain

$$\begin{aligned}
 \Psi_1(L, M) &\leq \sum_{j \geq M} \mathbf{E}^* \left[\mathbf{1}_{\{\tilde{T}_j \geq \frac{j}{2}\}} \prod_{i=1}^L (1 + c\tilde{T}_i \mathbf{1}_{\{\tilde{T}_i \geq \frac{i-1}{2}\}}) \right] \\
 &\leq \sum_{j \geq M} \mathbf{E}^* \left[(1 + c\tilde{T}_j) \mathbf{1}_{\{\tilde{T}_j \geq \frac{j}{2}\}} \prod_{i \neq j \leq L} (1 + c\tilde{T}_i \mathbf{1}_{\{\tilde{T}_i \geq \frac{i-1}{2}\}}) \right] \\
 &= \sum_{j \geq M} \mathbf{E}^* \left[(1 + c\tilde{T}_1) \mathbf{1}_{\{\tilde{T}_1 \geq \frac{j}{2}\}} \right] \prod_{i \neq j \leq L} (1 + c\mathbf{E}^*[\tilde{T}_i \mathbf{1}_{\{\tilde{T}_i \geq \frac{i-1}{2}\}}])
 \end{aligned}
 \tag{5.13}$$

Since \tilde{T}_1 has exponential tail under \mathbf{P}^* (cf. Remark 3.5), there exist $C_1, C_2 > 0$ such that

$$\mathbf{P}^*(\tilde{T}_1 \geq \ell) \leq \mathbf{E}^*[\tilde{T}_1 \mathbf{1}_{\{\tilde{T}_1 \geq \ell\}}] \leq C_1 e^{-C_2 \ell} \quad \text{for all } \ell \in \mathbb{N}.
 \tag{5.14}$$

This implies that

$$\Psi_1(L, M) \leq (1 + c) \sum_{j \geq M} C_1 e^{-C_2 \frac{j}{2}} \prod_{i=1}^{\infty} (1 + c C_1 e^{-C_2 \frac{i-1}{2}}) \leq c_1 e^{-c_2 M},
 \tag{5.15}$$

which concludes the proof of Claim 5.4. □

Proof of Claim 5.5 The claim is essentially a consequence of the renewal theorem. Note that by construction, we have $R_0 = 0$, $\mathcal{E}_1 = 1$, and $L_0(T_1, N_1, 1) = L_0^*(T_1, N_1, 1)$, and when $R_{i-1} \geq 1$ and $T_i = 1$, or when $T_i < R_{i-1}$, we must have $\mathcal{E}_i = 0$ and $L_{R_{i-1}}(T_i, N_i, 0) = L_{R_{i-1}}^*(T_i, N_i, 0)$. Therefore, with $A > 0$ to be chosen later, we can bound

$$\begin{aligned}
 M_L &:= \mathbf{E}^* \left[\prod_{i=1}^{\gamma L} \frac{L_{R_{i-1}}(T_i, N_i, \mathcal{E}_i)}{L_{R_{i-1}}^*(T_i, N_i, \mathcal{E}_i)} \mathbf{1}_{\{T_1 + \dots + T_{\gamma L} = L\}} \right] \\
 &\geq \mathbf{P}^*(T_1 + \dots + T_{\gamma L} = L, T_i = 1 \forall i \in [1, A], T_j < R_{j-1} \forall j \in [A + 1, \gamma L]).
 \end{aligned}
 \tag{5.16}$$

Recall that $(T_i, N_i, \mathcal{E}_i)_{i \in \mathbb{N}}$ is constructed from $(\tilde{V}_i, \tilde{T}_i, \tilde{N}_i)_{i \in \mathbb{N}}$ with law \mathbf{P}^* such that $\tilde{T}_i \geq T_i$ a.s., and when $\tilde{T}_i = 1$ or $\tilde{T}_i \leq R_{i-1}$, we have $T_i = \tilde{T}_i$ (cf. Section 4.3). Since $R_1, R_2 \geq 1$ and $R_i \geq \frac{i-1}{2}$ for $i \geq 3$, we can bound the r.h.s. of (5.16) by

$$\begin{aligned}
 M_L &\geq \mathbf{P}^*(\tilde{T}_1 + \dots + \tilde{T}_{\gamma L} = L, \tilde{T}_i = 1 \forall i \in [1, A], \tilde{T}_j < \frac{j-1}{2} \forall j > A), \\
 &= \mathbf{P}^*(\tilde{T}_1 = 1)^A \mathbf{P}^*(\tilde{T}_1 + \dots + \tilde{T}_{\gamma L - A} = L - A, \tilde{T}_i < \frac{A+i-1}{2} \forall i \geq 1),
 \end{aligned}
 \tag{5.17}$$

where $\tilde{\gamma}_L$ is the counterpart of γ_L for $(\tilde{T}_i)_{i \in \mathbb{N}}$ (recall (3.15)). Since $(\tilde{T}_j)_{j \in \mathbb{N}}$ is i.i.d. with exponential tail, we may pick $A \in \mathbb{N}$ large enough such that

$$\mathbf{P}^* \left(\tilde{T}_i < \frac{A+i-1}{2} \quad \forall i \geq 1 \right) \geq 1 - \frac{1}{4\mathbf{E}^*[\tilde{T}_1]}. \quad (5.18)$$

Having chosen A , the renewal theorem then ensures that there exists $L_0 \in \mathbb{N}$ such that

$$\mathbf{P}^*(\tilde{T}_1 + \dots + \tilde{T}_{\tilde{\gamma}_L - A} = L - A) \geq \frac{1}{2\mathbf{E}^*[\tilde{T}_1]} \quad \forall L > L_0. \quad (5.19)$$

Combining (5.18) and (5.19) then shows that the r.h.s. in (5.17) is bounded from below by a positive constant uniformly in $L \geq L_0$. The proof is then complete. \square

5.3 Proof of Lemma 5.2

The proof is similar to that of Lemma 5.1. Let $\delta > 0$ and $\kappa > 0$ and set

$$\begin{aligned} \beta_L &:= \mathbf{P}_{\text{unif},L}(T_1(\pi) + \dots + T_{\delta \log L}(\pi) \geq \kappa(\log L)^2) \\ &= \frac{|\{\pi \in \Omega_L : T_1 + \dots + T_{\delta \log L} \geq \kappa(\log L)^2\}|}{|\Omega_L|}. \end{aligned}$$

Since $T_1(\pi) + \dots + T_{\delta \log L} \geq \kappa(\log L)^2$ implies that $T_i \geq \kappa\delta^{-1} \log L$ for some $1 \leq i \leq \delta \log L$, similar to (5.5), we have

$$\beta_L \leq CL^3 \frac{\sum_{j=1}^{\delta \log L} \mathbf{E}^* \left[\mathbf{1}_{\{T_j \geq \kappa\delta^{-1} \log L\}} \prod_{i=1}^{\gamma_L} \frac{L_{R_{i-1}}(T_i, N_i, \mathcal{E}_i)}{L_{R_{i-1}}^*(T_i, N_i, \mathcal{E}_i)} \right]}{\mathbf{E}^* \left[\prod_{i=1}^{\gamma_L} \frac{L_{R_{i-1}}(T_i, N_i, \mathcal{E}_i)}{L_{R_{i-1}}^*(T_i, N_i, \mathcal{E}_i)} \mathbf{1}_{\{T_1 + \dots + T_{\gamma_L} = L\}} \right]} := CL^3 \frac{\Psi_2(L)}{D_L}. \quad (5.20)$$

By Claim 5.5, D_L is bounded away from 0 uniformly in L . Using Lemma 5.6 and (5.14), we obtain

$$\begin{aligned} \Psi_2(L) &\leq \sum_{j=1}^{\delta \log L} \mathbf{E}^* \left[\mathbf{1}_{\{\tilde{T}_j \geq \kappa\delta^{-1} \log L\}} \prod_{i=1}^L \left(1 + c\tilde{T}_i \mathbf{1}_{\{\tilde{T}_i \geq \frac{i-1}{2}\}} \right) \right] \\ &\leq (\delta \log L) \mathbf{E}^* \left[\left(1 + c\tilde{T}_1 \right) \mathbf{1}_{\{\tilde{T}_1 \geq \kappa\delta^{-1} \log L\}} \right] \prod_{i=1}^{\infty} \left(1 + c\mathbf{E}^*[\tilde{T}_1 \mathbf{1}_{\{\tilde{T}_1 \geq \frac{i-1}{2}\}}] \right) \\ &\leq (\delta \log L) c_1 e^{-c_2 \kappa\delta^{-1} \log L}, \end{aligned} \quad (5.21)$$

which tends to 0 as L tends to infinity if κ is chosen large enough. \square

5.4 Proof of Lemma 5.3

As in the proof of Lemmas 5.1 and 5.2, given $\delta > 0$, we set

$$\begin{aligned} \rho_L &:= \mathbf{P}_{\text{unif},L}(L - (T_1(\pi) + \dots + T_{\gamma_L}(\pi)) \geq \alpha \log L) \\ &= \frac{|\{\pi \in \Omega_L : (L - (T_1 + \dots + T_{\gamma_L})) \geq \alpha \log L\}|}{|\Omega_L|}. \end{aligned}$$

Similar to (5.5), we have

$$\rho_L \leq CL^3 \frac{\mathbf{E}^* \left[\mathbf{1}_{\{L - (T_1 + \dots + T_{\gamma_L}) \geq \alpha \log L\}} \prod_{i=1}^{\gamma_L} \frac{L_{R_{i-1}}(T_i, N_i, \mathcal{E}_i)}{L_{R_{i-1}}^*(T_i, N_i, \mathcal{E}_i)} \right]}{\mathbf{E}^* \left[\prod_{i=1}^{\gamma_L} \frac{L_{R_{i-1}}(T_i, N_i, \mathcal{E}_i)}{L_{R_{i-1}}^*(T_i, N_i, \mathcal{E}_i)} \mathbf{1}_{\{T_1 + \dots + T_{\gamma_L} = L\}} \right]} =: CL^3 \frac{\Psi_3(L)}{D_L}. \quad (5.22)$$

By Claim 5.5, D_L is bounded away from 0 uniformly in L . Since $L - (T_1 + \dots + T_{\gamma_L}) \geq \alpha \log L$ implies $\max\{T_1, \dots, T_L\} \geq \alpha \log L$, again by Lemma 5.6 and (5.14), we have

$$\begin{aligned} \Psi_3(L) &\leq \mathbf{E}^* \left[1_{\{\max\{T_1, \dots, T_L\} \geq \alpha \log L\}} \prod_{i=1}^{\gamma_L} \frac{L_{R_{i-1}}(T_i, N_i, \mathcal{E}_i)}{L_{R_{i-1}}^*(T_i, N_i, \mathcal{E}_i)} \right] \\ &\leq \mathbf{E}^* \left[1_{\{\max\{\tilde{T}_1, \dots, \tilde{T}_L\} \geq \alpha \log L\}} \prod_{i=1}^L (1 + c \tilde{T}_i 1_{\{\tilde{T}_i \geq \frac{i-1}{2}\}}) \right] \\ &\leq L \mathbf{E}^* \left[(1 + c \tilde{T}_1) 1_{\{\tilde{T}_1 \geq \alpha \log L\}} \right] \prod_{i=1}^{\infty} (1 + c \mathbf{E}^* [\tilde{T}_1 1_{\{\tilde{T}_1 \geq \frac{i-1}{2}\}}]) \leq c_1 L e^{-c_2 \alpha \log L}, \quad (5.23) \end{aligned}$$

which tends to 0 as L tends to infinity if α is chosen large enough. \square

References

- [1] N.R. Beaton and G.K. Iliev, *Two-sided prudent walks: a solvable non-directed model of polymer adsorption*, J. Stat. Mech. Theory Exp. (2015), no. 9, P09014, 23. MR-3412072
- [2] V. Beffara, S. Friedli, and Y. Velenik, *Scaling limit of the prudent walk*, Electronic Communications in Probability **15** (2010), 44–58. MR-2595682
- [3] M. Bousquet-Mélou, *Families of prudent self-avoiding walks*, Journal of combinatorial theory Series A **117** (2010), no. 3, 313 – 344. MR-2592903
- [4] J.C. Dethridge and A.J. Guttmann, *Prudent self-avoiding walks*, Entropy. MR-2465840
- [5] G. Giacomin, *Random polymer models*, Imperial College Press, World Scientific, 2007. MR-2380992
- [6] N. Pétrélis and N. Torri, *Collapse transition of the interacting prudent walk*, arXiv:1610.07542, 2016.
- [7] S.B. Santra, W.A. Seitz, and D.J. Klein, *Directed self-avoiding walks in random media*, Phys. Rev. E **63** (2001), no. 6, 067101.
- [8] L. Turban and J.M. Debierre, *Self-directed walk: a monte carlo study in three dimensions*, J. Phys. A **20** (1987), 3415 – 3418.
- [9] L. Turban and J.M. Debierre, *Self-directed walk: a monte carlo study in two dimensions*, J. Phys. A **20** (1987), 679 – 686. MR-0914064

Acknowledgments. R. Sun was supported by NUS grant R-146-000-220-112.

N. Torri was supported by the “Investissements d’avenir” program (ANR-11-LABX-0020-01).

Electronic Journal of Probability

Electronic Communications in Probability

Advantages of publishing in EJP-ECP

- Very high standards
- Free for authors, free for readers
- Quick publication (no backlog)
- Secure publication (LOCKSS¹)
- Easy interface (EJMS²)

Economical model of EJP-ECP

- Non profit, sponsored by IMS³, BS⁴, ProjectEuclid⁵
- Purely electronic

Help keep the journal free and vigorous

- Donate to the IMS open access fund⁶ (click here to donate!)
- Submit your best articles to EJP-ECP
- Choose EJP-ECP over for-profit journals

¹LOCKSS: Lots of Copies Keep Stuff Safe <http://www.lockss.org/>

²EJMS: Electronic Journal Management System <http://www.vtex.lt/en/ejms.html>

³IMS: Institute of Mathematical Statistics <http://www.imstat.org/>

⁴BS: Bernoulli Society <http://www.bernoulli-society.org/>

⁵Project Euclid: <https://projecteuclid.org/>

⁶IMS Open Access Fund: <http://www.imstat.org/publications/open.htm>