



HAL
open science

A Novel Observer Design for Sensorless Sampled Output Measurement: Application of Variable Speed Doubly Fed Induction Generator

A.A.R Al Tahir, R. Lajouad, F.Z. Chaoui, Ramdane Tami, T Ahmed-Ali, F
Giri

► To cite this version:

A.A.R Al Tahir, R. Lajouad, F.Z. Chaoui, Ramdane Tami, T Ahmed-Ali, et al.. A Novel Observer Design for Sensorless Sampled Output Measurement: Application of Variable Speed Doubly Fed Induction Generator. 12'th IFAC International workshop on Adaptation and Learning in Control and Signal Processing, Technische Universiteit Endhoven/ Despartment of Mechanica Engineering, Jun 2016, Eindhoven, Netherlands. pp.235 - 240, 10.1016/j.ifacol.2016.07.957 . hal-01465316

HAL Id: hal-01465316

<https://hal.science/hal-01465316>

Submitted on 18 Feb 2017

HAL is a multi-disciplinary open access archive for the deposit and dissemination of scientific research documents, whether they are published or not. The documents may come from teaching and research institutions in France or abroad, or from public or private research centers.

L'archive ouverte pluridisciplinaire **HAL**, est destinée au dépôt et à la diffusion de documents scientifiques de niveau recherche, publiés ou non, émanant des établissements d'enseignement et de recherche français ou étrangers, des laboratoires publics ou privés.

Public Domain

A Novel Observer Design for Sensorless Sampled Output Measurement: Application of Variable Speed Doubly Fed Induction Generator

A.A.R. Al Tahir *, R. Lajouad**, F.Z. Chaoui**, Ramdane Tami*,
T. Ahmed-Ali*, F. Giri*

*University of Caen Basse-Normandie, GREYC Lab UMR CNRS,
14032 Caen, France: e-mail: ali.altahir@unicaen.fr, fouadgiri@yahoo.fr

**University of Mohammed V, ENSET lab LM2PI, 10100 Rabat,
Morocco (e-mail: dsa.lajouad@gmail.com)

Abstract: This paper presents a novel exponentially convergent nonlinear observer design for variable speed doubly fed induction generators (DFIG). The main feature of the proposed observer lies in the use of sampled-data without necessitating mechanical sensors, making the observer more reliable. A main component of the observer is an inter-sampled predictor of the output current vector. The observer exponential convergence is established and analyzed using Lyapunov stability technique and the small gain theorem. The proposed observer combines the advantage of a high-gain structure in terms of convergence speed and the continuity of the estimated state trajectory. One difficulty of the present observer design problem is that the electromagnetic torque is not related to the output by an injective map. The simulation results in variable speed DFIG operation are provided to confirm the theoretical results.

Keywords: DFIG; High - gain observer; Sampled - data; Sensorless measurements; ISS stabilization.

1. INTRODUCTION

It is widely recognized that the induction machine has become one of the main actuators for industrial use. Indeed, as compared to the DC machine, it provides a better power/mass ratio, simpler maintenance (as it includes no mechanical commutators), and a relatively lower cost.

It is largely agreed that these machines have promising perspectives in the industrial actuator held. This has motivated an intensive research activity on induction machine control, especially over the last 15 years (Giri, 2013; El Fadili et al., 2013).

Doubly-fed induction machines (DFIM) have recently entered into common use. This is due almost exclusively to the advent of wind power technologies for electricity generation.

Doubly-fed induction generator (DFIG) are by far the most widely used type of doubly-fed electric machine, and are one of the most common types of generator used to produce electricity in wind turbines. Doubly-fed induction generators have a number of advantages over other types of generators when used in wind turbines. The primary advantage is that they allow the amplitude and frequency of their output voltage to be maintained at a constant value, no matter the speed of the wind blowing on the wind turbine rotor. Because of this, doubly-fed induction generator can be directly connected to the ac power network and remain synchronized at all times with the ac power network. Other advantages include the ability to control the power factor (e. g., to maintain the power factor at unity), while keeping the power

electronics devices in the wind turbine at a moderate size (Boldea and Nasar, 2010, Lajouad et al., 2014).

Measuring mechanical quantities is always a challenge for control and visualization of the states of the system under studies. In fact the synthesis of an observer for the system is still beneficial to measure inaccessible magnitudes and quantities or requiring high-end sensors as claimed by (Bastin and Gevers, 1988, Marino and Tomei, 1996, Gildas, 2007, Zhang, 2002, Besancon et al., 2006).

Much research work has been done around the synthesis observers for doubly fed induction machine. For example in (Li et al., 2010) the author suggests an adaptive estimate of rotor currents of the machine. This estimate depends on the time varying of the machine parameters. This estimate has applications where measurement of rotor currents is practically difficult.

In (Lascu et al., 2013) the paper investigates a family of stator and rotor flux observers of doubly-fed induction generators (DFIG). Four stator flux observer topologies are described and compared. All proposed schemes use the voltage and current models connected in parallel or in series. In this structure no mechanical quantity is estimated.

In (Beltran et al., 2011), the paper deals with the sensorless control of a doubly-fed induction generator (DFIG) based wind turbine. The sensorless control scheme is based on a high-order sliding mode (HOSM) observer to estimate only the DFIG rotational speed.

All these design methods provide continuous-time observers that need discretization for practical implementation purpose (Laila et al, 2006). The point is that exact discretization is a highly complex issue due to the strong nonlinearity of the observer. On the other hand, there is no guarantee that

approximate discrete-time versions can preserve the performances of the original continuous-time adaptive observers. This explains why quite a few studies have, so far, focused on designing sampled-data adaptive observers that apply to nonlinear systems subject to parametric uncertainty. In (Deza et al., 1992), discrete-continuous time observers have been designed on the basis of the system continuous-time model. The proposed observers include in effect two parts: an open-loop state estimator (with zero innovation term) operating between two successive sampling times and a feedback state estimator operating at the sampling times. The output estimation error is shown to be exponentially vanishing under ad hoc assumptions.

Another approach has been proposed by (Raff et al., 2008) that consisted in using a single hybrid continuous-discrete observer with a ZOH sampled innovation term. The observer is applicable to a class of systems with Lipschitz nonlinearity in the state and linear matrix inequalities (LMIs) are established to meet global stability. In (Kravaris, 2013) a hybrid continuous-discrete observer involving an inter-sample output predictor has been proposed. Only the output predictor is reinitialized at each sampling time, while the state estimate is continuously updated by a standard structure observer where the (unavailable) inter-sample output measurement is replaced by the output prediction. The observer is applicable to triangular globally Lipschitz systems and features exponential convergence of the state observation.

This rest of this paper is organized as follows: the reduced model of the DFIG system is described in Section 2. In Section 3 we deal with the candidate observer of the designated system. The fundamental theorem describing the proposed observer dynamic performances is presented in Section 4; all results are validated by numerical simulation through MATLAB/SIMULINK environment, as given in Section 5. Finally, conclusions and remarks is given in Sections 6.

2. REDUCED MODEL OF THE DFIG

It is important to initiate with a good and appropriate model of the DFIG when designing the observer. The model of doubly fed induction generator, in d-q coordinates, is defined by the following equations given in (El Fadili et al., 2013, 2012):

$$v_{sd} = R_s i_{sd} + \dot{\phi}_{sd} - \omega_s \phi_{sq} \quad (1a)$$

$$v_{sq} = R_s i_{sq} + \dot{\phi}_{sq} - \omega_s \phi_{sd} \quad (1b)$$

$$v_{rd} = R_r i_{rd} + \dot{\phi}_{rd} - (\omega_s - p\omega) \phi_{rq} \quad (1c)$$

$$v_{rq} = R_r i_{rq} + \dot{\phi}_{rq} - (\omega_s - p\omega) \phi_{rd} \quad (1d)$$

$$\begin{bmatrix} \phi_{sd} \\ \phi_{sq} \\ \phi_{rd} \\ \phi_{rq} \end{bmatrix} = \begin{bmatrix} L_s & 0 & M_{sr} & 0 \\ 0 & L_s & 0 & M_{sr} \\ M_{sr} & 0 & L_r & 0 \\ 0 & M_{sr} & 0 & L_r \end{bmatrix} \begin{bmatrix} i_{sd} \\ i_{sq} \\ i_{rd} \\ i_{rq} \end{bmatrix} \quad (1e)$$

$$\dot{\omega} = (T_{em} - T_g - f_v \omega) / J \quad (1f)$$

where R_s, L_s, R_r and L_r are, respectively the stator and rotor resistances and self-inductances, and M_{sr} is the mutual inductance between the stator and the rotor windings.

$\phi_{sd}, \phi_{sq}, \phi_{rd}$ and ϕ_{rq} denote the rotor and stator flux components. $(i_{sd}, i_{sq}, i_{rd}, i_{rq})$ and $(v_{sd}, v_{sq}, v_{rd}, v_{rq})$ are the stator and rotor components of the current and voltage respectively. p is the number of pole-pair, ω_s is the stator angular frequency, ω represents the generator speed. f_v, J and T_g are, respectively the viscous friction coefficient, the total moment of inertia for lumped mass model (rotor blades, hub, and generator), and generator torque.

Equation (1a-1f) can be re-written as follows:

$$v = \begin{bmatrix} R_s I_2 & O_2 \\ O_2 & R_r I_2 \end{bmatrix} i + \frac{d\Phi}{dt} + \begin{bmatrix} \omega_s J_2 & O_2 \\ O_2 & (\omega_s - p\omega) J_2 \end{bmatrix} \Phi \quad (2a)$$

$$\Phi = \begin{bmatrix} L_s I_2 & M_{sr} I_2 \\ M_{sr} I_2 & L_r I_2 \end{bmatrix} i \quad (2b)$$

$$\frac{d\omega}{dt} = \frac{1}{J} (T_{em} - T_g - f_v \omega) \quad (2c)$$

T_{em} is the electromagnetic torque represented by:

$$T_{em} = p M_{sr} (i_{rd} i_{sq} - i_{rq} i_{sd}) = p M_{sr} i^T T_0 i \quad (3a)$$

$$T_0 = \begin{bmatrix} O_2 & J_2 \\ O_2 & O_2 \end{bmatrix} \quad (3b)$$

$i = [i_{sd} \ i_{sq} \ i_{rd} \ i_{rq}]^T$, $v = [v_{sd} \ v_{sq} \ v_{rd} \ v_{rq}]^T$ and $\Phi = [\phi_{sd} \ \phi_{sq} \ \phi_{rd} \ \phi_{rq}]^T$ denote, respectively the state vector of stator and rotor current, voltage and flux in (d-q) reference coordinate, where

$$J_2 = \begin{bmatrix} 0 & -1 \\ 1 & 0 \end{bmatrix}, I_2 = \begin{bmatrix} 1 & 0 \\ 0 & 1 \end{bmatrix} \text{ and } O_2 = \begin{bmatrix} 0 & 0 \\ 0 & 0 \end{bmatrix}$$

Then the model of DFIG in the (d; q) coordinates system (El Fadili et al., 2013, 2012) can be given by the following equations:

$$i = \gamma M_1 v + M_{23} i - p \gamma M_4 \omega i \quad (4a)$$

$$\dot{\omega} = (p M_{sr} i^T T_0 i - T_g - f_v \omega) / J \quad (4b)$$

$$\dot{T}_g = 0 \quad (4c)$$

Equation (4c) is motivated by the fact that, in numerous applications, the generator torque T_g is assumed bounded, derivable and its derivative is also bounded. Indeed, the generator torque T_g is actually infrequent, that is, the input generator torque takes a value with slowly varying.

with $\gamma = \frac{1}{\varrho L_s L_r}$, $\varrho = 1 - \frac{M_{sr}^2}{L_s L_r}$, M_1, M_2, M_3, M_{23} and M_4 are constant matrices that can be represented as follows:

$$M_1 = \begin{pmatrix} L_r I_2 & -M_{sr} I_2 \\ -M_{sr} I_2 & L_s I_2 \end{pmatrix} \quad (5a)$$

$$M_2 = \begin{pmatrix} R_s L_r I_2 & -M_{sr} R_r I_2 \\ -M_{sr} R_s I_2 & R_r L_s I_2 \end{pmatrix} \quad (5b)$$

$$M_3 = \begin{pmatrix} J_2 & O_2 \\ O_2 & J_2 \end{pmatrix} \quad (5c)$$

$$M_{23} = -M_3 \omega_s - \gamma M_2 \quad (5d)$$

$$M_4 = \begin{pmatrix} M_{sr}^2 J_2 & M_{sr} L_r J_2 \\ -M_{sr} L_s J_2 & -L_s L_r J_2 \end{pmatrix} \quad (5e)$$

Now, let us introduce the following state variables representation:

$x_{11} = i_{sd}$, $x_{12} = i_{sq}$, $x_{13} = i_{rd}$, $x_{14} = i_{rq}$, $x_2 = \omega$, $x_3 = T_g$ and let's $x_1 = [x_{11} \ x_{12} \ x_{13} \ x_{14}]^T$. Then the system (4) can be re-written in the reduced form as :

$$\dot{x} = f(v, x) \quad (6a)$$

$$y = h(x) = x_1 \quad (6b)$$

$h(x)$ designs a measured states variables of the system (6), and $f(v, x) = [f_1, f_2, f_3, f_4, f_5, f_6](v, x)$, with:

$$[f_1, f_2, f_3, f_4]^T(v, x) = \gamma M_1 v + M_{23} x_1 - p \gamma M_4 x_2 x_1 \quad (7a)$$

$$f_5(v, x) = \frac{1}{J} (p M_{sr} x_1^T T_0 x_1 - x_3 - f_v x_2) \quad (7b)$$

$$f_6(v, x) = 0 \quad (7c)$$

Recall that the electromagnetic torque, T_{em} expresses in terms of the current vector as follows:

$$T_{em} = p M_{sr} i^T T_0 i \stackrel{\text{def}}{=} h(i) \quad (8)$$

Using (4a), it is readily checked that \dot{T}_{em} undergoes the following equation:

$$\dot{T}_{em} = p M_{sr} i^T (T_0 + T_0^T) \frac{di}{dt} = S_1(i, v) - S_2(i) \omega \quad (9)$$

with:

$$S_1(i, v) = 2p M_{sr} i^T T_0 (\gamma M_1 v + M_{23} i) \quad (10a)$$

$$S_2(i) = 2p^2 \gamma M_{sr} i^T T_0 M_4 i \quad (10b)$$

by combining with (4b-c) constitutes a suitable mathematical state - space representation for the estimation of the generator rotor speed ω . For writing convenience, the system representation is re-written as:

$$\dot{T}_{em} = S_1(i, v) - S_2(i) \omega \quad (11a)$$

$$\dot{\omega} = -\frac{1}{J} T_{em} + \frac{1}{J} T_g - \frac{f_v}{J} \omega \quad (11b)$$

$$\dot{T}_g = 0 \quad (11c)$$

Throughout this paper, to avoid the mistakes and confusion between the notations of full order system variables and the corresponding reduced model, the following more compact form of the reduced model with new notations of state variables is given:

$$\dot{\xi} = Y_1(i) \xi + Y_2(i, \xi) \quad (12a)$$

$$y = C \xi \quad (12b)$$

where:

$$\xi \stackrel{\text{def}}{=} [\xi_1 \ \xi_2 \ \xi_3]^T = [T_{em} \ \omega \ T_g]^T \quad (13a)$$

$$Y_1(i) = \begin{pmatrix} 0 & -S_2(i) & 0 \\ 0 & 0 & \frac{-1}{J} \\ 0 & 0 & 0 \end{pmatrix} \quad (13b)$$

$$Y_2(i, \xi) = \begin{pmatrix} S_1(i, v) \\ \frac{\xi_1}{J} - \frac{f_v}{J} \xi_2 \\ 0 \end{pmatrix} \quad (13c)$$

$$C = [1 \ 0 \ 0] \quad (13d)$$

For physical point of view and domain of working principle, it is supposed that all physical state variables are bounded in domain of interest as stated in **A₂**. To overcome the blow up state variables in finite time that may reduce the escape time of the system and to restrict the initial peaking phenomenon, which are practically reasonable (Khalil, 2002, Khalil et al, 1993). It turns out that the state vector $\xi(t)$ is bounded (i.e. $\|\xi(t)\| \leq \rho_\xi, \forall t$, for some constant $0 < \rho_\xi < \infty$) is an upper bound.

This system (11) satisfies the observability rank condition, if the Jacobian of the vector formed by the Lie derivative terms

$[\xi_1 \ -S_2(i)\xi_2 \ -\frac{S_2(i)}{J}\xi_3]^T$ is Full structural rank. This condition is all time verified because $S_2^2(i)$ is non null too.

3. PROPOSED OBSERVER DESIGN

In the case where the current vector $i(t)$ is accessible to measurements for all $t \geq 0$, the system model given by (11) almost fits the observable canonical form for which the standard (continuous-time) high-gain observer applies (see e.g. Gauthier et al., 1994). As a matter of fact, the system model in (11) differs from the canonical form in that the first state variable, denoted by, T_{em} , is not (directly) measurable. This can only be computed using the (supposedly available) current measurements $i(t)$ using the relation (8). One difficulty is that relation (8) is not output injective. Another difficulty is that the current vector $i(t)$ is not accessible to measurements all the time, $t \geq 0$. Only sampled-data measurements $i(t_k)$, ($k = 0, 1, 2, \dots$) are presently available at sampling instant. Therefore, the following (non-standard) high-gain sampled-output nonlinear observer is proposed:

$$\dot{\hat{\xi}} = Y_1(\sigma(z)) \hat{\xi} + Y_2(\sigma(z), \hat{\xi}) - \theta \Lambda^{-1} K (C \hat{\xi} - h(\sigma(z))) \quad (14a)$$

$$\dot{z} = \gamma M_1 v + M_{23} z - p \gamma M_4 \hat{\xi}_2 \sigma(z) \quad (14b)$$

$$\forall t_k < t < t_{k+1}, \quad k = 0, 1, 2, \dots$$

$$z(t_k) = i(t_k) \quad (14c)$$

$$\Lambda = \text{diag} \left[1 \quad \frac{1}{\theta} \quad \frac{1}{\theta^2} \right] \quad (14d)$$

with $K \in \mathbb{R}^3$, being any fixed vector gain such that the following inequality holds, for some scalar $\mu > 0$ and some positive definite matrix $P = P^T$:

$$(Y_1(\sigma(z)) - KC)^T P + P(Y_1(\sigma(z)) - KC) \leq -\mu I_3 \quad (15)$$

with, $\hat{x}(0)$ is arbitrarily initial condition chosen in space.

A₁: $\sigma(z)$ denotes the saturation function of the variable z bounded between (1,-1) can be defined as follows,

$$\sigma(z) = \lim_{t \rightarrow \infty} \tanh(z(t)) \min(|z|, i_M) \quad (16)$$

Knowing that i_M is any upper bound of the current i.e.

$$i_M \geq \sup_{0 \leq t < \infty} \|i(t)\| \quad (17)$$

Note that the knowledge of i_M is not an issue because the maximum amplitude of the current vector i in DFIG is a priori known in practice.

A₂: The DFIG stays in domain working principle, it can be denoted by \mathcal{U} which defined as follows: $\mathcal{U} = \{X \in \mathbb{R}^6 \text{ such that: } \|\Phi_{sd}\|, \|\Phi_{sq}\|, \|\Phi_{rd}\|, \|\Phi_{rq}\| \leq \Phi^{\text{Max}}, \text{ and } \|i_{rd}\|, \|i_{rq}\| \leq I^{\text{Max}} \text{ with, } \|\omega_g\| \leq \omega^{\text{Max}}, \text{ and } \|T_g\| \leq T^{\text{Max}}.$

Knowing that the functions, ψ_{nom} , I_{nom} , ω_{nom} and T_{nom} are the nominal models and upper bound of the actual state variables such as rotor flux, generator current, generator rotor speed and mechanical torque can be physically obtained and satisfied.

The above observer presentation is completed by a number of relevant remarks:

- a) The existence of a gain $K \in \mathbb{R}^3$ satisfying (15) is a consequence of Lemma 4.0 in (Gauthier et al., 1994).
- b) Comparing (14b)-(14c) and (4a), it is readily seen that the variable $z(t)$ undergoes, between two sampling instants, the same differential equation as the current $i(t)$. Furthermore, $z(t)$ is reinitialized at each sampling instant, it is set to the value of the current at those instants. It turns out that $z(t)$ represents a prediction of the current $i(t)$ over each interval (t_k, t_{k+1}) . In view of (8), it turns out that $h(z(t))$ is a prediction of the electromagnetic torque, T_{em} .
- c) Notice that, the current prediction $z(t)$ is replaced by its saturated version $\sigma(z(t))$ everywhere on the right side of the observer (14a)-(14c). The introduction of the saturation function in state observers is a recent usual practice (see e.g. references). Presently, the saturation process will prove to be crucial to ensure exponential convergence of the observer (because the function $Y_2(z, \xi)$ is not Lipschitz in z (see equations (10a) and (13c)). On the other hand, since the saturated value $\sigma(z(t))$ is closer to the current $i(t)$ than $z(t)$, the observer (14a)-(14c) will necessarily perform better (it will be more speedier) than the basic version not involving saturation.
- d) Clearly, the sampled-output observer (14a)-(14c) does not involve a ZOH innovation term (as those in e.g. (Dabroom et al., 2001)). The present observer includes inter - ample prediction innovation correction term. But, it differs from previous sampled observers of this type (e.g. Ahmed-Ali et al., 2009) in that the first state variable T_{em} in the model (11) is related to the measurable generator current i through a noninjective relation, namely (8).

4. OBSERVER ANALYSIS

Theorem (Main result): Given a class of nonlinear system state in (12) with compact form, submits to assumptions (A_1 and A_2). Let us consider a high - gain sampled output observer coupled with inter sampled output predictor given by (14) such that the evaluation of high gain design parameter is chosen for $k_i, i = 1; 2; 3$, gain matrix corresponding to measurement error, for $0 < \theta^* < \infty$ be sufficiently large values of parameter such that for all $\theta > \theta^*$,

$$\theta^* \left(\mu - \frac{\rho_h \|K\| \|P\|}{\zeta} \right) - \|P\| \left(2\rho_G + \frac{1}{\zeta} (\rho_\xi \rho_F + \rho_G) \right) > 0 \quad (18)$$

with $P \stackrel{\text{def}}{=} P^T > 0$, is the solution of algebraic Lyapunov equation with constant scalar $0 < \rho_h, \rho_\xi, \rho_F, \rho_G < \infty$ exist and the free design parameter ζ be selected such that, $\mu - \frac{\rho_h \|K\| \|P\|}{\zeta} > 0$. To ensure exponential convergence of the observation error between estimated and measured states towards zero, there exists a real positive bounded $0 < t - t_k < \tau$, with $\tau = \sup_{0 \leq k < \infty} (t_k - t_{k-1})$, the estimation error is ultimately bounded and the corresponding bound can be made as small as possible by choosing θ high enough value.

Moreover, there exist real positives $(M_1; \beta_1; \beta_2)$, such that the closed loop observation error $\tilde{\xi}(t) = \hat{\xi}(t) - \xi(t)$ satisfies the following inequality $\forall t \in [t_k, t_{k+1}), k \in \mathbb{N}$,

$$\|\tilde{\xi}\| \exp^{\alpha t/2} \leq M_1 \frac{1 - \beta_1 \tau \exp^{\alpha \tau/2}}{1 - (\beta_1 + \nu \beta_2) \tau \exp^{\alpha \tau/2}}, \quad (19)$$

So, the whole system is globally exponentially stable (GES) based on ISS stabilization where $\hat{\xi}(t)$ is the estimate trajectory given by (14a) associated with (v, y) for whatever initial conditions $(\xi_0, \hat{\xi}_0) \in \xi^2$.

Proof of Theorem 1: The proof of Theorem (main result) has been removed due to the limitation of the number of pages.

5. SIMULATIONS RESULTS

To implement this formulation of the observer, the system of equations (4) are used with the numerical values given in the Table.1.

Table 1. DFIG system nominal Parameters

Characteristics	Symbol	Value	Unity
DFIG			
Nominal power	Pn	5.00	kW
Mutual inductor	Msr	0.103	H
Stator resistor	Rs	0.163	Ω
Stator cyclic inductor	Ls	0.309	H
Rotor resistor	Rr	0.140	Ω
Rotor cyclic inductor	Lr	0.035	H
Number of pole pairs	p	2	-
Rotor inertia	J	2.2	Nm/rd/s ²
Viscous friction	f	0.004	Nm/rd/s
Three-phase network			
Voltage	En	220/380	V
Network frequency	fn	50	Hz

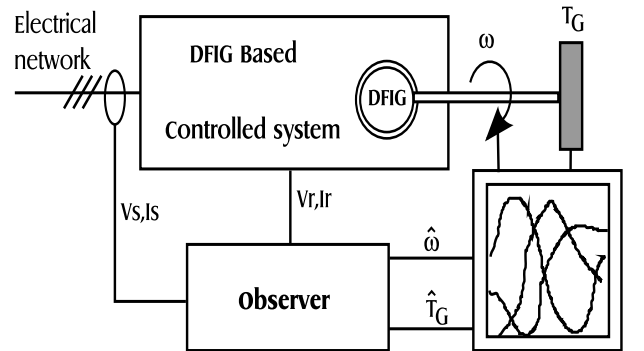

Fig. 1. Experimental setup of the DFIG-based WECS simulator.

These values issued from the technical documentation of a doubly fed induction generator. We shall estimate rotational speed and generator torque, without using mechanical sensors, such as position encoder which are most costly and unreliable.

To validate the robustness of the proposed observer, the test benchmark include, some limit cases:

- Mechanical torque is zero (the wind speed is less than the start-up speed of the wind turbine).
- the mechanical torque is greater than the nominal torque,
- Slow variation of mechanical torque (usual case),
- Abrupt variation of mechanical torque (theoretical case).

Therefore, the reference of the generator torque T_g will take the form shown in Fig. 2. Fig. 3 shows generator torque and its estimate \hat{T}_G with zooming in for short period of time around ($t = 5s$), for complete one cycle of 20s.

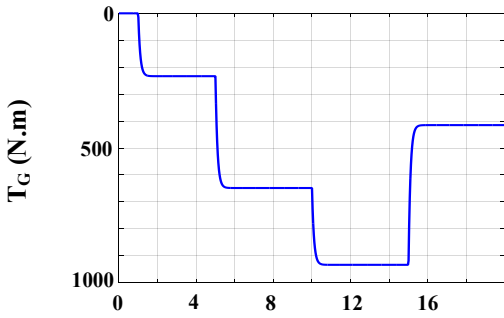

Fig 2. Generator torque profile in (N.m).

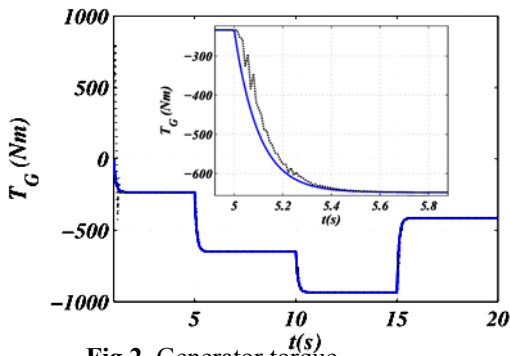

Fig 2. Generator torque

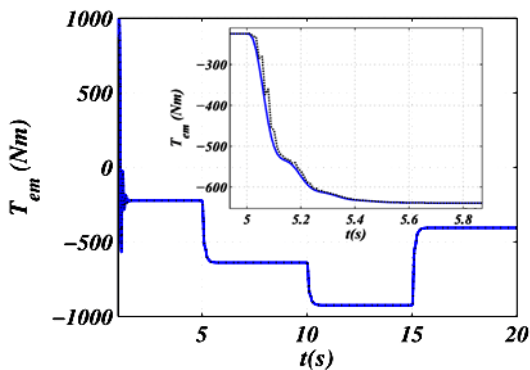

Fig 3. Electromagnetic torque

With the test conditions mentioned above, one was implanted the simulation in the MATLAB/SIMULINK environment with the tracking high gain parameter $\theta = 175$, the gain matrix corresponding to measurement error $K = [7; 25; 30]^T$ and the sampling interval $T_s = 2s$ or $f_s = 0.5 Hz$. In each figure is displayed in solid and blue lines the measurement of

the variable at the system output, and in dashed line the measurement of the variable at the output of the observer.

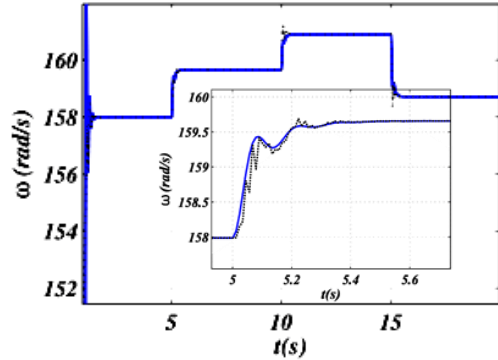

Fig 4. Rotation speed.

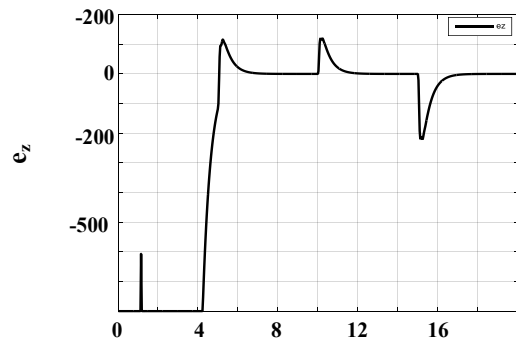

Fig 6. Output state prediction error, e_z

Fig. 3 show that the estimated generator torque reached quickly the real torque. The response time is less than 0.2s. Similarly, one note that the observed electromagnetic torque joined the actual electromagnetic torque. Fig. 4 illustrates the electromagnetic torque and its estimates. In Fig. 5, one notice that the observed rotation speed reached the second region of operation in less than 0.5s. Fig. 6 clarifies the output state prediction error for complete one cycle of 20s. However, as expected, the fast transient of generator input torque affect momentarily the estimation and prediction process. This phenomena is depicted through the appearance of overshoot on the figures shown in (3,4,5 and 6), respectively at times (5s, 10s, 15s) of a complete one cycle. There is no error on the initial conditions at the entry of the unobservability region and the provided estimates still converge to their true closed loop trajectories.

Sampled output state predictor is re-initialized at each sampling instant and remains continuous between two sampling instants through ZOH device, which is a mathematical model of the practical signal reconstruction operating at a specific sampling interval.

The proposed observer hooks - up to the system states approximately after (3-5) sampled measurements. It is observed that at low value (150) of observer design parameter θ , it allows to occur free noise estimates, but these states estimates vary slowly and are not capable of tracking the real state variations. On the other side, a very large value of θ (200) permits a good tracking performance of the missing

states variations, but for such case, the observer becomes noise sensitive since the noise level in the provided estimates is significantly high. So, we must make a good compromise between both cases by selecting optimum gain parameter (175).

6. CONCLUSIONS AND REMARKS

This paper tackles the problem of designing a sampled – data observer for the doubly fed induction generator DFIG. The aim is to get online estimate of the mechanical variables based on the electrical measurement. First, the machine has been modeled in the (d - q) reference frame (4).

The proposed observer combines the advantage of a high - gain structure in terms of convergence speed and an output state predictor, which remains continuous between two adjacent sampling instants. An observer (14) has been designed and analyzed successfully with the assistance of Lyapunov stability tools method and ISS property. It is formally shown that all variables converge to a neighborhood of their true values. In the particular case of constant load mechanical generator torque, the estimates converge exponentially to their true values. Then theoretical results are confirmed by simulation.

One succeeded to introduce an explicit expression of continuous time output prediction error between two consecutive sampling instants depends on other sampled high gain design parameters and system nonlinearity. The recent developments of lower cost digital systems makes wide range applications of DFIG, fast dynamic response, robustness against external disturbances are considered the most important criteria of high performance systems.

REFERENCES

- Abderrahime El Fadili, Fouad Giri, Abdelmounime El Magri, Luc Dugard, and Zahra Chaoui, Fatima (2012). Adaptive nonlinear control of induction motors through ac/dc/ac converters. *Asian Journal of Control*, 14(4):1470-1483.
- Besancon Gildas (2007). *Nonlinear observers and applications*. Springer, 2007. ISBN 3-540-73502-X.
- Brice Beltran, Mohamed Benbouzid, Tarek Ahmed-Ali, and Herv Mangel (2011). DFIG - based wind turbine robust control using high-order sliding modes and a high gain observer. *International Review on Modelling and Simulations*, 4(3):1148 -1155.
- C. Lascu, I. Boldea, F. Blaabjerg, and W. Chen (2013). A class of flux observers for doubly-fed induction generators used in small power wind generation systems. In *Energy Conversion Congress and Exposition (ECCE)*, IEEE, 2289-2295.
- Dabroom, A.M.; Khalil, H.K. (2001). Output feedback sampled-data control of nonlinear systems using high-gain observers. *Automatic Control, IEEE Transactions on*, 46(11): 1712-1725.
- Deza, F., Busvelle, E., Gauthier, J. P., & Rakotopara, D. (1992). High gain estimation for nonlinear systems. *Systems & control letters*, 18(4), 295-299.
- Fouad Giri (2013). *AC Electric motors control: advanced design techniques and applications*. Wiley & sons, 2013. ISBN 9781118574249.
- Gauthier, J. P., & Kupka, I. A. (1994). Observability and observers for nonlinear systems. *SIAM Journal on Control and Optimization*, 32(4): 975-994.
- Georges Bastin and Michael R Gevers (1988). Stable adaptive observers for nonlinear time-varying systems. *Automatic Control, IEEE Transactions on*, 33(7):650-658.
- Gildas Besancon, J De Leon-Morales, and Oscar Huerta-Guevara (2006). On adaptive observers for state affine systems. *International journal of Control*, 79(06):581-591.
- Ion Boldea and Syed A Nasar (2010). *The induction machine handbook*. CRC press.
- Kravaris, C. (2014). Design of sampled data nonlinear observers, alternative approaches in the context of observer error linearization. *International Journal of Automation and Power Engineering (IJAPE)*, 3 (1):14 - 17.
- Karafyllis, I., and Kravaris, C. (2009). From continuous-time design to sampled-data design of observers. *Automatic Control, IEEE Transactions on*, 54(9), 2169 - 2174.
- Khalil,H.(2002). *Nonlinear vsystems*. 3’rd edition, Prentic – Hall, Inc, ISBN-13: 978-0130673893.
- Khalil, H. K. and Esfandiari, F. (1993). Semiglobal stabilization of a class of nonlinear systems using output feedback. *IEEE Transaction on Automatic and Control*, 38(9). 1412 - 1415.
- Laila, D. S., Lovera, M., & Astolfi, A. (2011). A discrete-time observer design for spacecraft attitude determination using an orthogonality-preserving algorithm. *Automatica*, 47(5), 975 - 980.
- Rachid Lajouad, Abdelmounime El Magri, Abderrahim El Fadili, Fatima-Zahra Chaoui, and Fouad Giri (2015). Adaptive nonlinear control of wind energy conversion system involving induction generator. *Asian Journal of Control*, 17 (4): pp. 1365-1376.
- Raff, T., Kögel, M., & Allgöwer, F. (2008). Observer with sample-and-hold updating for Lipschitz nonlinear systems with nonuniformly sampled measurements. In *American Control Conference*, 5254-5257.
- Tarek Ahmed-Ali, Romain Postoyan, and Françoise Lamnabhi-Lagarrigue (2009). Continuous - discrete adaptive observers for state affine systems. *Automatica*, 45(12): 2986 -2990.