



HAL
open science

Regularization and Minimization of Codimension-One Haefliger Structures

Gaël Meigniez

► **To cite this version:**

Gaël Meigniez. Regularization and Minimization of Codimension-One Haefliger Structures. Journal of Differential Geometry, 2017, 107 (1), pp.157-202. 10.4310/jdg/1505268031 . hal-01449923v2

HAL Id: hal-01449923

<https://hal.science/hal-01449923v2>

Submitted on 26 Apr 2019

HAL is a multi-disciplinary open access archive for the deposit and dissemination of scientific research documents, whether they are published or not. The documents may come from teaching and research institutions in France or abroad, or from public or private research centers.

L'archive ouverte pluridisciplinaire **HAL**, est destinée au dépôt et à la diffusion de documents scientifiques de niveau recherche, publiés ou non, émanant des établissements d'enseignement et de recherche français ou étrangers, des laboratoires publics ou privés.

REGULARIZATION AND MINIMIZATION OF CODIMENSION-ONE HAEFLIGER STRUCTURES

GAËL MEIGNIEZ

Dedicated to Paul Schweitzer.

ABSTRACT. On compact manifolds of dimensions 4 and more, we give a proof of Thurston's existence theorem for foliations of codimension one; that is, they satisfy some h-principle in the sense of Gromov. Our proof is an explicit construction not using the Mather homology equivalence. Moreover, the produced foliations are minimal, that is, all leaves are dense. In particular, there exist minimal, C^∞ , codimension-one foliations on every closed manifold of dimension at least 4 whose Euler characteristic is zero.

1. INTRODUCTION

W. Thurston gave, in two famous papers [18] [19], some general methods to make foliations on closed manifolds. The results and the proofs pertain with no doubt to M. Gromov's *homotopy principle*; however, the techniques differ from Gromov's; also, the role of formal data falls to some rather elaborate objects previously introduced by A. Haefliger, the Γ -structures.

We are interested in the case of codimension one. See section 2 below for the Haefliger structures of codimension one (Γ_1 -structures). Practically, one may think of them as the singular foliations of codimension one with Morse-type singularities; which is the generic case. A concordance between two Γ_1 -structures on M means a Γ_1 -structure on $M \times [0, 1]$.

In this introduction, to fix ideas, we restrict consideration to the closed manifolds; to the smooth (C^∞) differentiability class; and to the co-oriented case: all hyperplane fields, foliations, and Γ_1 -structures, are understood to be co-oriented. See section 6 for a more general result.

THEOREM 1.1. (*Thurston [19]*) *On a closed manifold M , let ξ be a Γ_1 -structure, and let τ be a hyperplane field. Then, there is on M a*

Date: April 16, 2018.

2000 Mathematics Subject Classification. 57R30.

Key words and phrases. Foliation, h-principle, Haefliger's Γ -structure.

codimension-one foliation which is concordant to ξ (as a Γ_1 -structure) and homotopic to τ (as a hyperplane field).

The proof given in [19] follows a scheme of construction in three steps. First, one makes on M a foliation with “holes”; that is, parts of the manifold remain nonfoliated. Second, one fills the holes; that is, one extends the foliation into them. The filling argument is constructive, substantial, and remains amazing four decades later. Third, in order to correct the concordance class of the foliation as a Haefliger structure, one changes the foliation, in some ball in M , for another piece of foliation, given by the Mather homology equivalence [13].

In general, the produced foliation has some compact leaves, because, while filling the holes, some kind of Reeb components are created inside ([19], p. 264); and because there will in general also be some compact leaves in the piece given by the Mather homology equivalence.

Notoriously, the subsequent study of foliations was strained by the belief that Thurston had “cleaned out” and even “killed” the subject [20] (as a doctoral student, I was still told so in Paris in the mid 80’s). It was believed, and became a paradigm, that, in codimension one, the Mather homology equivalence was unavoidable in the proof of the h-principle. However, in 1976, Thurston himself did not write so. He called his step 3 “a nuisance” and wrote: “Currently, *step 3* seems to involve some nonelementary background about classifying spaces for Haefliger structures and groups of diffeomorphisms.” [19]

The present paper gives a constructive proof, not involving such background, of the existence theorem for codimension-one foliations, on closed manifolds of dimension at least 4. Moreover, the constructed foliations are *minimal*, that is, all the leaves are dense in M .

THEOREM A. *On a closed manifold M of dimension at least 4, let ξ be a Γ_1 -structure, and let τ be a hyperplane field. Then, there is on M a minimal codimension-one foliation which is concordant to ξ (as a Γ_1 -structure) and homotopic to τ (as a hyperplane field).*

COROLLARY 1.2. *Every closed, connected manifold of dimension at least 4 and whose Euler characteristic is zero, admits a minimal, smooth, codimension-one foliation.*

For example, \mathbf{S}^5 does, as well as $\mathbf{S}^3 \times \mathbf{S}^2$, and $\mathbf{S}^3 \times \mathbf{S}^1$, and connected sums such as $(\mathbf{S}^2 \times \mathbf{S}^2) \sharp (\mathbf{S}^3 \times \mathbf{S}^1) \sharp (\mathbf{S}^3 \times \mathbf{S}^1)$. Of course, this contrasts with the Novikov closed leaf theorem in dimension 3. Our Corollary answers some classical questions raised by Lawson and Schweitzer [12][17].

Recall that P. Schweitzer proved that on every closed manifold of dimension at least 4, every augmented Γ_1 -structure can be homotoped to some foliation of class C^1 without compact leaf [17].

In dimension 3, one already has a constructive proof of the h-principle for codimension-one foliations by elementary means, not using Mather's homology equivalence [11]. The constructed foliation has a precise geometric form, associated to some open book decomposition of the manifold.

Overview of the proof of Theorem A, and organization of the paper.

In section 3, one proves Corollary 1.2. To this end, one first easily makes on M a Morse-singular Γ_1 -structure ξ whose leaves are dense, and whose set of singularities is partitioned into pairs; in each pair the two singularities are of successive Morse indices $i, i + 1$; they are joined by an arc A transverse to ξ , called a *cancellation arc*. One can then cancel the pair, much like in elementary Morse theory, at the price of the apparition of a nonfoliated hole parallel to A . Then, one fills the holes and gets a minimal codimension-one foliation \mathcal{F} . The difficulty lies in the filling of the holes.

In section 4, one fixes the concordance class of \mathcal{F} as a Γ_1 -structure. Actually, the methods of section 3 produce, at the same time as a holed foliation, a holed concordance between the given Γ_1 -structure and the holed foliation. One fills the holes in the concordance at the same time as the holes in the foliation.

In section 5, one fixes the homotopy class of \mathcal{F} as a hyperplane field. The method is inspired by the elementary Pontryagin-Thom theory for the homotopy classes of mappings $M^n \rightarrow \mathbf{S}^{n-1}$. We choose a vector field ∇ which is a pseudogradient for ξ (definition 5.1 below). Given a nonsingular vector field V on M , we consider in M the set of the points where V and ∇ are nonpositively colinear. This is generically a curve bounded by the singularities; it comes with a framing. One can arrange that this curve is actually a collection of arcs, each of which is transverse to ξ and bounded by two singularities of successive indices; and that the framing is hyperbolic. We take these arcs for cancellation arcs. With some care, after one has cancelled the singularities and filled the holes, the output foliation \mathcal{F} admits naturally a negatively transverse vector field which is homotopic to V .

Finally, section 6 gives the theorem in its full generality.

We would like to stress the aspects in which our proof follows Thurston, and where we actually depart from him.

We use Morse singularities where he uses round ones; this is not great a difference. The holes that we get, are just the same as his. To fill the

holes, we use his method, but two critical differences. First, he puts some kind of Reeb components into the holes; we don't; this difference is of course necessary to obtain a minimal foliation. Second, in the induction process called by him “rolling up the holes”, he uses the n -dimensional torus T^n ; we use $\mathbf{S}^{n-1} \times \mathbf{S}^1$ instead. Our construction is more symmetric and more functorial, because $\mathbf{S}^{n-1} \times \mathbf{S}^1$ is, in $\mathbf{S}^n \times \mathbf{S}^1$, the fixed point set of an involution; while T^n in T^{n+1} is not. This additional symmetry and functoriality is critical in our section 4, to fill the holes of the holed concordance, and thus get a genuine concordance, without any call to the Mather homology equivalence. The methods of our section 5 to fix the homotopy type of the hyperplane field are completely different from Thurston's “inflation”.

It is a pleasure to thank François Laudenbach for sharing his interrogations about the actual status of the Mather homology equivalence in Thurston's construction of codimension-one foliations; and for his listening and observations. I thank the referees, whose critiques and suggestions led to improve the precision of some proofs, and the readability of the paper.

1.0.1. *Conventions, vocabulary and notation.* One denotes by \mathbf{D}^k the compact unit ball in \mathbf{R}^k , and by \mathbf{S}^{k-1} the unit sphere $\partial\mathbf{D}^k$. In particular, \mathbf{D}^1 is the interval $[-1, +1]$. A basepoint is generally written $*$. Also, one sometimes regards \mathbf{D}^2 as the unit disk in \mathbf{C} , and uses the basepoint 1 in $\mathbf{S}^1 = \partial\mathbf{D}^2$.

In any product $X \times Y$, where Y is an interval or a circle, the projection to the second factor is called the *height function*. The foliation that it defines is the *height foliation*. The unit vector field negatively parallel to Y is the *height gradient*.

By *whirling* a foliation \mathcal{F} in a domain diffeomorphic to some product $X \times \mathbf{D}^1$ where \mathcal{F} is the height foliation, we mean changing \mathcal{F} in this domain for the suspension of some representation of $\pi_1 X$ into the diffeomorphisms of \mathbf{D}^1 .

The *stabilization* of a foliated manifold (V, \mathcal{F}) by a manifold X is the foliated manifold $(X \times V, \text{pr}_2^* \mathcal{F})$.

Most figures evoke three-dimensional situations; however, recall that this low dimension is excluded in the text. I have sometimes pointed under which aspects the dimension reduction may be misleading. In general, plain (resp. dotted) lines represent some curves tangential (resp. transverse) to the foliation. A dotted arrow indicates the transverse orientation.

2. MORSE CANCELLATION FOR Γ_1 -STRUCTURES

In this preliminary section, we give a version, adapted to Γ_1 -structures, of the classical Morse Cancellation Lemma for a pair of critical points of a Morse function [15][16]. We first give a version of the classical Lemma, in order to make precise the place where the function is actually changed.

Let f be a Morse function on an n -manifold M ; let s, s' be two critical points of respective Morse indices i and $i + 1$, such that $f(s) < f(s')$; let $f(s) < t < f(s')$; let ∇ be a negative pseudogradient for f on M . Assume that every pseudogradient line arriving at s or starting from s' reaches $f^{-1}(t)$. Write $W^s(s)$ and $W^u(s')$ for the stable and the unstable manifolds respectively; consider the disks $\mathcal{D}^s := W^s(s) \cap f^{-1}[f(s), t]$ and $\mathcal{D}^u := W^u(s') \cap f^{-1}[t, f(s')]$, and the attachment spheres $\partial\mathcal{D}^s$ and $\partial\mathcal{D}^u$. The classical cancellation position can be stated as follows: in $f^{-1}(t)$, the spheres $\partial\mathcal{D}^s$ and $\partial\mathcal{D}^u$ meet transversely in a single point. If they do, we call \mathcal{D}^s and \mathcal{D}^u a *cancellation pair of disks* for f at s and s' .

OBSERVATION 2.1. In this situation, the germ of f along $\mathcal{D}^s \cup \mathcal{D}^u$ is completely determined, up to composition by two diffeomorphisms at the source and at the target, by n and i . This follows easily from the following *relative Morse Lemma* (not found in the literature, but the proof is an exercise): Let $0 \leq m \leq n$; let f be the germ of a function at 0 in \mathbf{R}^n , such that $f(0) = 0$ and $df(0) = 0$. Assume that $d^2f(0)$ and $d^2f(0)|_{\mathbf{R}^m}$ are both nondegenerate. Then, f is conjugate to $d^2f(0)$ by the germ of a diffeomorphism of \mathbf{R}^n preserving \mathbf{R}^m .

EXAMPLE 2.2. We shall use the two following elementary examples several times, as models. We give the explicit formulas, in view of some future computations. Fix an index $0 \leq i \leq n - 1$.

1) One has on \mathbf{R}^n the usual, polynomial function of degree 3 with a pair of points in cancellation position:

$$(1) \quad P_i(x) := Q_i^n(x_1, \dots, x_{n-1}) + x_n^3 - 3x_n$$

where

$$Q_i^n(x_1, \dots, x_{n-1}) := - \sum_{j=1}^i x_j^2 + \sum_{j=i+1}^{n-1} x_j^2$$

Of course, P_i has exactly two critical points $s := (0, \dots, 0, +1)$, $s' := (0, \dots, 0, -1)$. Define the disk \mathcal{D}^s (resp. \mathcal{D}^u) by $x_n \geq 0$ (resp. $x_n \leq 0$) and $f(x) \leq 0$ (resp. $f(x) \geq 0$) and $x_1 = \dots = x_i = 0$ (resp. $x_{i+1} = \dots = x_{n-1} = 0$). Obviously, \mathcal{D}^s and \mathcal{D}^u form a cancellation pair of disks for P_i at s and s' , tangential to the Euclidean gradient of P_i .

2) A variant will be more practical, being conjugate to x_n on some neighborhood of the infinity. Write $B_r \subset \mathbf{R}^n$ for the ball $\|x\| \leq r$. Let $r \geq 1$ be so large that \mathcal{D}^s and \mathcal{D}^u are interior to B_r . Choose some smooth plateau function ϕ on $[0, +\infty)$, equal to -1 on $[0, r]$, equal to $+1$ on some neighborhood $[R, +\infty)$ of $+\infty$, and such that $0 \leq \phi' < 2/3$. Consider on \mathbf{R}^n the function

$$f_i(x) := Q_i^n(x_1, \dots, x_{n-1}) + x_n^3 + 3\phi(\|x\|)x_n$$

On the ball B_r , the function f_i , being equal to P_i , has the same critical points s, s' and the same cancellation pair of disks. Outside this ball, the function f_i is noncritical. Indeed, for every $1 \leq j \leq n-1$, one has

$$(2) \quad \frac{\partial f_i}{\partial x_j} = x_j (\pm 2 + 3\|x\|^{-1}x_n\phi'(\|x\|))$$

which is zero iff $x_j = 0$; while

$$(3) \quad \frac{\partial f_i}{\partial x_n} = 3(x_n^2 + \phi(\|x\|)) + 3\|x\|^{-1}x_n^2\phi'(\|x\|)$$

which is positive wherever $|x_n| > 1$. Finally, outside B_R one has $f_i = x_n \circ F_i$, where F_i is the self-diffeomorphism of \mathbf{R}^n defined by

$$F_i(x) := (x_1, \dots, x_{n-1}, Q_i^n(x_1, \dots, x_{n-1}) + x_n^3 + 3x_n)$$

LEMMA 2.3. *Let f be a Morse function on a manifold M ; let s, s' be two critical points of successive indices admitting a cancellation pair of disks $\mathcal{D}^s, \mathcal{D}^u$; let N be a sufficiently small neighborhood of $\mathcal{D}^s \cup \mathcal{D}^u$ in M .*

Then, N admits a noncritical function g equal to f close to ∂N .

Moreover, every connected component of every level set of g in N , meets ∂N .

This version of the Cancellation Lemma is implicit in [10]. However, we give another proof, fitting the needs of our sections 4 and 5.

Proof of Lemma 2.3. By Observation 2.1, it is enough to verify the Lemma for one standard model. Fix a large positive constant C , and consider on \mathbf{R}^n the function $f(x) := C^{-1}f_i(F_i^{-1}(Cx))$ (see Example 2.2, (2)). For C large enough, f equals x_n on $U := \mathbf{R}^n \setminus (\mathbf{D}^{n-1} \times [-1, +1])$; the critical points of f are a pair s, s' of indices $i, i+1$ such that $f(s) < 0 < f(s')$; and this pair is in cancellation position. That is, f admits on \mathbf{R}^n a descending pseudogradient ∇ , equal to $-\partial/\partial x_n$ on U ; in $f^{-1}(0)$, the boundaries of the disks $\mathcal{D}^s := W^s(s) \cap f^{-1}[f(s), 0]$ and $\mathcal{D}^u := W^u(s') \cap f^{-1}[0, f(s')]$ meet transversely in a single point. Write $(\nabla^\tau)_{\tau \in \mathbf{R}}$ for the flow of this pseudogradient.

It is well-known that the level set $f^{-1}(0)$ is diffeomorphic with the once-punctured product of spheres $L := (\mathbf{S}^{n-i-1} \times \mathbf{S}^i) \setminus (*, *)$. This can be seen with elementary Morse theory: indeed, $f^{-1}(0)$ results from $f^{-1}(-1) = \mathbf{R}^{n-1}$ by an elementary surgery along the attachment sphere $W^u(s) \cap f^{-1}(-1)$. But this sphere is unknotted in $f^{-1}(-1)$: it bounds an i -disk which is the image, through the flow of ∇ , of $(\partial\mathcal{D}^u) \setminus (\partial\mathcal{D}^s \cap \partial\mathcal{D}^u)$. For the same reason, the attachment framing is trivial. So, $f^{-1}(0)$ is diffeomorphic with L ; and they will be identified. The diffeomorphism carries $\partial\mathcal{D}^s$ (resp. $\partial\mathcal{D}^u$) to $\mathbf{S}^{n-i-1} \times *$ (resp. $* \times \mathbf{S}^i$).

Recall also that in L , every neighborhood of the bouquet $(\mathbf{S}^{n-i-1} \times *) \cup (* \times \mathbf{S}^i)$ can engulf, by an isotopy in L , any compact subset of L . This follows also from the elementary Morse theory, applied to the canonical Morse function on $\mathbf{S}^{n-i-1} \times \mathbf{S}^i$.

Let N be any compact neighborhood of $\mathcal{D}^s \cup \mathcal{D}^u$ in \mathbf{R}^n , with smooth boundary ∂N . We have to show that $f|(\mathbf{R}^n \setminus N)$ extends inside N as a function without critical points. Shrinking N , we can arrange that $N \subset f^{-1}(-1, +1)$. After an isotopy of the embedding of N into \mathbf{R}^n which does not change $f|N$, we can moreover assume that $\partial N \cap f^{-1}(0)$ is contained in U (since $N \cap L$ can engulf $(\mathbf{D}^{n-1} \times [-1, +1]) \cap L$). Let $\epsilon > 0$ be so small that

$$\partial_0 N := (\partial N) \cap f^{-1}[-\epsilon, +\epsilon]$$

is contained in U . Put

$$\partial_+ N := (\partial N) \cap f^{-1}[\epsilon, 1]$$

$$\partial_- N := (\partial N) \cap f^{-1}[-1, -\epsilon]$$

Obviously, $\partial_+ N$ (resp. $\partial_- N$) is disjoint from $W^u(s')$ (resp. $W^s(s)$). In other words, for every $x \in \partial_+ N$ (resp. $x \in \partial_- N$), the negative (resp. positive) half of the pseudogradient line through x hits $\mathbf{R}^{n-1} \times 1$ (resp. $\mathbf{R}^{n-1} \times (-1)$). Let K be the union of the pseudogradient arcs between $\partial_+ N$ and $\mathbf{R}^{n-1} \times 1$, together with the pseudogradient arcs between $\partial_- N$ and $\mathbf{R}^{n-1} \times (-1)$. The singularities s, s' do not lie in the compact set K : we can rescale ∇ to arrange that moreover, $\nabla \cdot f = -1$ on a neighborhood of K . Then, the identity

$$f \circ \nabla^\tau = f - \tau$$

holds, for every $\tau \in \mathbf{R}$ (resp. $\tau \leq 0$, resp. $\tau \geq 0$), on a neighborhood of $\partial_0 N$ (resp. $\partial_+ N$, resp. $\partial_- N$).

For $x \in N$ close to ∂N and for $0 \leq h \leq 1$, put

$$\phi_h(x) := \nabla^{-hf(x)/\epsilon}(x)$$

So,

$$f \circ \phi_h = (1 + h/\epsilon)f$$

As a first consequence, (ϕ_h) induces an isotopy of embeddings of ∂N into \mathbf{R}^n . Also, $\phi_1(\partial N) \subset U$. One extends (ϕ_h) by an isotopy of embeddings of N into \mathbf{R}^n , denoted by $(\bar{\phi}_h)$, coinciding with (ϕ_h) close to ∂N . On N , the function

$$g := (1 + h/\epsilon)^{-1}x_n \circ \bar{\phi}_1$$

is noncritical, and coincides with f close to ∂N .

Obviously, every connected component of every level set of g in N meets ∂N . \square

Next, we recall the notion of a codimension-one *Haefliger structure* — more briefly a Γ_1 -*structure* — on an n -manifold M . Recall that in this section, the smooth (C^∞) differentiability class and the co-orientability are understood.

DEFINITION 2.4. [4][5] On the manifold M , a (smooth, co-oriented) Γ_1 -structure is a foliation ξ of codimension one on some neighborhood of $M \times 0$ in $M \times \mathbf{R}$, transverse to each fibre $x \times \mathbf{R}$; or more precisely, the germ along $M \times 0$ of such a foliation.

Then, for every manifold N and every smooth mapping $F : N \rightarrow M$, one has on N a pullback Γ_1 -structure $F^*(\xi)$.

VOCABULARY 2.5. The *singularities* of ξ are the points of M where $M \times 0$ is not transverse to ξ . Write their set as $\text{Sing}(\xi) \subset M$. The restriction of ξ to $M \times 0$ induces a foliation on $M \setminus \text{Sing}(\xi)$. One makes no distinction between “foliation” and “regular Γ_1 -structure”.

A *concordance* between two Γ_1 -structures ξ_0, ξ_1 on M , is a Γ_1 -structure on the manifold $M \times [0, 1]$ whose restriction to $M \times i$ is ξ_i , for $i = 0, 1$.

Every real-valued function f defines on its domain a co-oriented Γ_1 -structure ξ : the pullback through f of the regular Γ_1 -structure on the real line. One also calls f a *first integral* of ξ . Obviously, every Γ_1 -structure admits a local first integral in a neighborhood of every point.

A Γ_1 -structure is qualified *Morse* if its local first integrals are Morse functions.

For example, on the compact unit disk $\mathbf{D}^k \subset \mathbf{R}^k$, one has two Morse Γ_1 -structures ξ_{can}^k and $-\xi_{\text{can}}^k$, defined respectively by the functions $x \mapsto \|x\|^2$ and $x \mapsto -\|x\|^2$.

Now, consider a Morse Γ_1 -structure ξ on an n -manifold M .

DEFINITION 2.6. A *stable* (resp. *unstable*) k -disk for ξ at a singularity s of index i , is the image of an embedding $F : \mathbf{D}^k \rightarrow M$ such that $F(0) = s$, and that $F^*(\xi) = \xi_{\text{can}}^k$ (resp. $F^*(\xi) = -\xi_{\text{can}}^k$).

DEFINITION 2.7. (See Figure 11 below) A *cancellation pair* of disks $(\mathcal{D}^s, \mathcal{D}^u)$ for ξ at its singularities s and s' , of respective indices i and $i + 1$ (where $0 \leq i \leq n - 1$), is as follows:

- (1) \mathcal{D}^s is a stable $(n - i)$ -disk at s and \mathcal{D}^u is an unstable $(i + 1)$ -disk at s' ;
- (2) $\mathcal{D}^s \cap \mathcal{D}^u = \partial\mathcal{D}^s \cap \partial\mathcal{D}^u$ is a single point x ;
- (3) $\partial\mathcal{D}^s$ and $\partial\mathcal{D}^u$ are transverse at x in the leaf of ξ through x .

LEMMA 2.8. (Cancellation) *Under these hypotheses, let N be a small enough open neighborhood of $\mathcal{D}^s \cup \mathcal{D}^u$ in M .*

*Then, N admits a (regular) foliation \mathcal{N} equal to ξ close to ∂N .
Moreover, no leaf of \mathcal{N} is relatively compact in N .*

Indeed, obviously, ξ admits a first integral in a small neighborhood of $\mathcal{D}^s \cup \mathcal{D}^u$; and this first integral admits a pseudogradient tangential to \mathcal{D}^s and \mathcal{D}^u . Lemma 2.3 applies.

3. MAKING A MINIMAL FOLIATION.

Let M be a closed connected manifold of dimension $n \geq 4$ whose Euler characteristic is zero. In this section, the aim is to construct a minimal foliation of codimension one and class C^∞ on M . The smooth (that is, C^∞) differentiability class is understood; and all Γ_1 -structures are understood to be co-oriented.

The construction will be in three steps. First, one will make a minimal Morse Γ_1 -structure on M . Then, the singularities will be canceled by pairs, at the price of some domains in M left nonfoliated — the so-called *holes*. Third, the holes will be filled, that is, the foliation will be extended inside them. The two first steps are easy.

3.1. First step: making a minimal Morse Γ_1 -structure. The construction of a minimal Morse Γ_1 -structure on every manifold of dimension at least 3 is not difficult, and already known [1]. Here, we give a construction which fits the needs of section 4.

One starts with any Morse Γ_1 -structure ξ on M , for example the one defined by some Morse function.

Then, one gets rid of local extrema, that is, singularities of extremal indices 0 and n (Figure 1). Consider for example some singularity s of ξ of index 0. Close to s , one creates a pair of singularities s' , s'' of respective indices 1 and 2. Now, ξ admits a local first integral

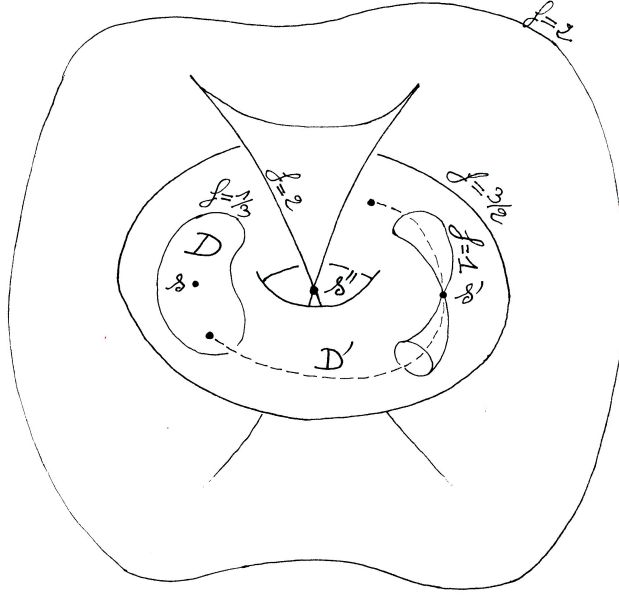

FIGURE 1. Replacement of a singularity of index 0 by one of index 2 and a Reeb component.

f which is a self-indexed Morse function, such that $f^{-1}([0, 3/2]) \cong \mathbf{D}^{n-1} \times \mathbf{S}^1$ contains exactly two critical points of f : s and s' . Let $D := f^{-1}([0, 1/3])$, a small stable n -disk at s (Definition 2.6). Choose for s' an unstable 1-disk $D' \cong \mathbf{D}^1$ such that $f(\partial D') = \{1/3, 2/3\}$. One cancels s and s' using the pair (D, D') (Lemma 2.8).

One can remark that, here, the cancellation process amounts, in the solid torus $f^{-1}([0, 3/2])$, to change ξ for an n -dimensional Reeb component. Of course, the compact toric leaves will be destroyed in the sequel of the construction.

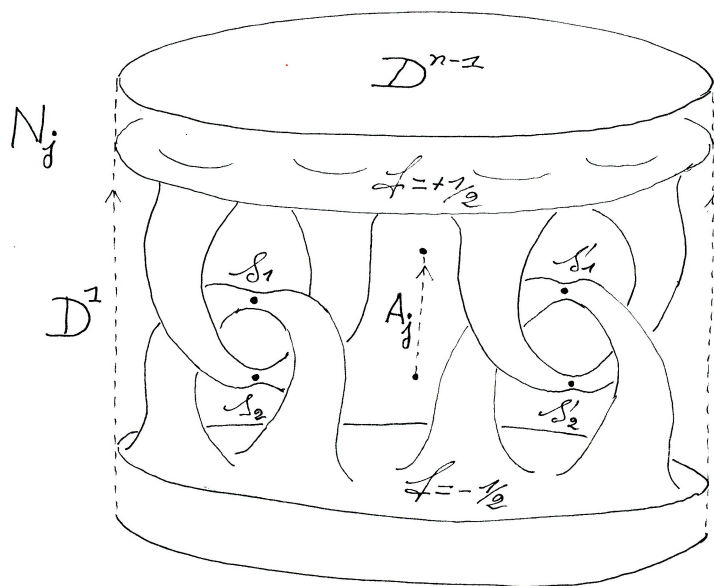

FIGURE 2. Minimizing plug.

As a whole, s has been replaced by s'' , which is of index 2, and a Reeb component. In the same way, every singularity of index n is replaced by one of index $n - 2$, and a Reeb component.

Then, ξ being free of local extrema, it admits a total transversal, that is, a finite disjoint union of compact arcs A_j embedded in M transversely to ξ , and such that every leaf meets at least one of them. One will make ξ minimal by the following modification in some small neighborhood N_j of each arc A_j (Figure 2).

The neighborhood N_j is identified with $\mathbf{D}^{n-1} \times \mathbf{D}^1$, in such a way that $A_j = 0 \times [-1/4, +1/4]$; and that $\xi|_{N_j}$ is the height foliation (see 1.0.1). A Morse function f is made on N_j , from the height function, by creating two pairs of singularities (s_1, s_2) and (s'_1, s'_2) of respective indices 1 and 2 and 1 and 2, in cancellation position. The function f is still the height function close to ∂N_j . One makes $f(s_1), f(s'_1) < -1/2$ and $f(s_2), f(s'_2) > 1/2$. The domain $f^{-1}[-1/2, +1/2]$ is diffeomorphic to $L \times [-1/2, +1/2]$, where L is obtained from \mathbf{D}^{n-1} by two elementary surgeries of index 1.

Two diffeomorphisms α, α' of the interval $[-1/2, +1/2]$, both flat on the identity at $\pm 1/2$, are chosen such that they commute, and that every orbit in the open interval $(-1/2, +1/2)$ under the group generated by α and α' is dense there. One has the representation

$$\pi_1 L \rightarrow \text{Diff}_+[-1/2, +1/2] : \gamma \mapsto (\alpha)^{(a\gamma)}(\alpha')^{(a'\gamma)}$$

where a and a' are Poincaré-dual in L to the stable attachment spheres of s_1 and s'_1 , respectively.

Then, we whirl f between the singularities. That is, we define a Morse Γ_1 -structure ξ_{plg} on N_j by f , except in the domain $f^{-1}[-1/2, +1/2]$, where ξ_{plg} is the suspension of the above representation. One can arrange that ξ_{plg} coincides with the height foliation close to ∂N_j .

Every leaf of ξ_{plg} in $f^{-1}(-1/2, +1/2)$ is dense there.

Having changed ξ to ξ_{plg} inside each N_j , we obtain a new Morse Γ_1 -structure ξ_{min} on M . Every leaf of ξ_{min} meets some solid cylinder N_j in its open subset $f^{-1}(-1/2, +1/2)$, and is dense there. So, every leaf of ξ_{min} is locally dense. So, every leaf of ξ_{min} is dense in M .

3.2. Second step: canceling the singularities. The second step of the construction of a minimal foliation on M is to cancel the singularities of the minimal Morse Γ_1 -structure ξ_{min} , at the price of leaving some nonfoliated holes.

First, we modify ξ_{min} by creating if necessary some pairs of new singularities of indices 1 and 2, 2 and 3, \dots , $n-2$ and $n-1$, in order that the singularities of ξ_{min} can be abstractly matched into pairs of successive indices. This is possible, since $\chi(M) = 0$. We don't require, at the moment, any cancellation position; two matched singularities can be very distant in the manifold. Still denote by ξ_{min} the resulting minimal Morse Γ_1 -structure.

Consider one of the pairs s, s' of matched singularities. Their indices are respectively $i \geq 1$ and $i+1 \leq n-1$. By the Morse Lemma, there are a small stable $(n-i)$ -disk \mathcal{D}^s at s , and a small unstable $(i+1)$ -disk \mathcal{D}^u at s' , disjoint from \mathcal{D}^s . The leaves of ξ_{min} being dense, one has in M an embedded arc A , positively transverse to ξ , from some boundary point of \mathcal{D}^s to some boundary point of \mathcal{D}^u , and otherwise disjoint from \mathcal{D}^s and \mathcal{D}^u . We are going to force the condition of Lemma 2.8, that is, the existence of a pair of cancellation disks intersecting once on their boundaries, by a whirl (see paragraph 1.0.1) of ξ_{min} close to A , at the price of a hole. We call A a ‘‘cancellation arc’’.

A small open neighborhood U of A is identified with $\mathbf{R}^n = \mathbf{R}^{n-i-1} \times \mathbf{R}^i \times \mathbf{R}$, in such a way that

- $\xi_{\text{min}}|_U$ is the height foliation, defined by the last coordinate x_n ;

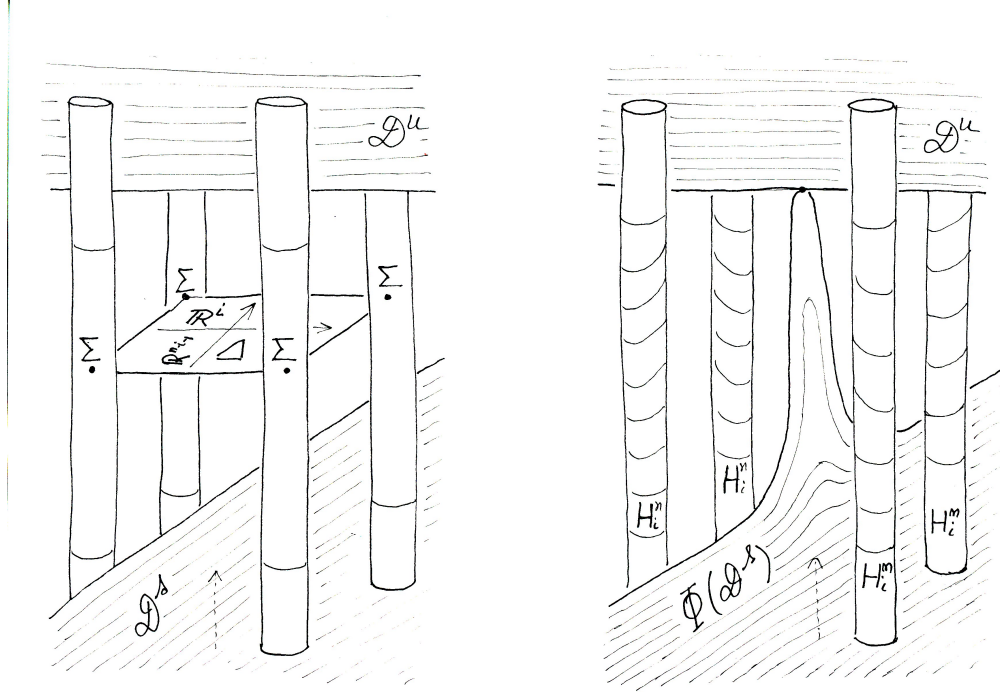

FIGURE 3. Before and after the whirl.

- $\mathcal{D}^s \cap U = \mathbf{R}^{n-i-1} \times 0 \times (-\infty, -1/2]$;
- $\mathcal{D}^u \cap U = 0 \times \mathbf{R}^i \times [1/2, +\infty)$.

(Figure 3, left). One considers in $\mathbf{R}^{n-1} = \mathbf{R}^{n-i-1} \times \mathbf{R}^i$ the unit bidisk $\Delta := \mathbf{D}^{n-i-1} \times \mathbf{D}^i$ and its corner $\Sigma := \mathbf{S}^{n-i-2} \times \mathbf{S}^{i-1}$. Every loop γ in $\mathbf{R}^{n-1} \setminus \Sigma$ has a linking number $\ell(\gamma)$ with Σ , that is, the algebraic number of intersections of γ with $\mathbf{D}^{n-i-1} \times \mathbf{S}^{i-1}$. One chooses a diffeomorphism ϕ of \mathbf{R} , whose support is compact and contained in $(-1, +1)$, and such that $\phi(-1/2) = +1/2$ (in the next paragraph, more conditions will be imposed on ϕ , to be able to fill the holes). One gets a representation $\rho(\gamma) := \phi^{\ell(\gamma)}$ of the fundamental group of $\mathbf{R}^{n-1} \setminus \Sigma$ into $\text{Diff}_c(\mathbf{R})$. The suspension of ρ gives a foliation ξ_{whl} on $\mathbf{R}^n \setminus (\Sigma \times \mathbf{D}^1)$, well-defined up to a vertical isotopy, “vertical” meaning parallel to the x_n -axis.

We can arrange that ξ_{whl} is the height foliation on $\mathbf{R}^n \setminus (\Delta \times \mathbf{D}^1)$ and on $0 \times \mathbf{R}^i \times \mathbf{R}$. In restriction to $\mathbf{R}^{n-i-1} \times 0 \times \mathbf{R}$, the foliation ξ_{whl} is the image of the height foliation by some vertical, compactly supported isotopy Φ . The boundaries $\partial(\mathcal{D}^u \cap U)$ and $\partial\Phi(\mathcal{D}^s \cap U)$ meet at the point $(0, \dots, 0, 1/2)$, transversely in the leaf of ξ_{whl} through this point.

The set that remains nonfoliated is $\Sigma \times \mathbf{D}^1$, but it is better to regard as nonfoliated the interior of its small tubular neighborhood $H_i^n \cong$

$\mathbf{D}^2 \times \Sigma \times \mathbf{D}^1$, called a *hole* (figure 3, right). The boundary ∂H_i^n splits into a horizontal boundary $\mathbf{D}^2 \times \Sigma \times \pm 1$ and a vertical boundary $(\partial \mathbf{D}^2) \times \Sigma \times \mathbf{D}^1$. Both horizontal components $\mathbf{D}^2 \times \Sigma \times \pm 1$ are tangent to ξ_{whl} and without holonomy. On the other hand, the vertical boundary is transverse to ξ_{whl} ; and ξ_{whl} induces on $(\partial \mathbf{D}^2) \times \Sigma \times \mathbf{D}^1$ a structure of foliated \mathbf{D}^1 -bundle above the base $(\partial \mathbf{D}^2) \times \Sigma$; the monodromy above the loop $\partial \mathbf{D}^2$ is ϕ (due to the whirl), while the monodromy above any loop in Σ is the identity of \mathbf{D}^1 .

At the price of leaving this nonfoliated hole, s can be cancelled with s' . Precisely, let us think again of $U \cong \mathbf{R}^n$ as an open subset in M . Extending Φ to the whole of \mathcal{D}^s by the identity, one gets an embedding Φ of \mathcal{D}^s into $M \setminus H_i^n$, isotopic to the identity: the small disk \mathcal{D}^s pushes a pseudopod along the arc A until it touches the boundary of \mathcal{D}^u . Extending ξ_{whl} by ξ_{min} outside U , one gets a Morse Γ_1 -structure on $M \setminus H_i^n$, for which $\Phi(\mathcal{D}^s)$ and \mathcal{D}^u form a cancellation pair (Definition 2.7). Cancel s with s' (Lemma 2.8).

Having done so for each pair of matched singularities, one gets a (regular) foliation ξ_{hol} on $M_{\text{hol}} := M$ minus the holes. Finally, ξ_{hol} is also minimal, in the sense that all of its leaves are dense in M_{hol} . Indeed, clearly the minimality property of ξ_{min} was preserved through the whirl, and through the cancellation of the singularities (thanks to the last sentence of Lemma 2.8).

3.3. Third step: filling the holes. Here, much is borrowed from Thurston [19]; but there are also some substantial differences. A complete account is necessary as well for the sake of sections 4 and 5. I shall indicate the places where we depart significantly from [19].

VOCABULARY 3.1. In a general way, by a *hole* we mean a compact manifold H with boundary and corners, together with, along ∂H , a germ \mathcal{H} of foliation of codimension one in H . *Filling* the hole means extending this germ by a foliation \mathcal{F} inside H . We are also interested to fill it *without interior leaf*: every leaf of \mathcal{F} meets ∂H .

Most holes will have the following *standard* forms. One has $H = B \times \mathbf{D}^1$ (*straight hole*) or $H = B \times \mathbf{S}^1$ (*round hole*), where B is a compact connected manifold whose boundary is nonempty, smooth and connected. In the straight case, on some neighborhood of $B \times \partial \mathbf{D}^1$, the germ \mathcal{H} is the height foliation. In both cases, $\mathcal{H}|(\partial B) \times \mathbf{D}^1$ (resp. $\mathcal{H}|(\partial B) \times \mathbf{S}^1$) is a foliated \mathbf{D}^1 (resp. \mathbf{S}^1)-bundle, that is, the suspension of some representation

$$\rho : \pi_1 \partial B \rightarrow \text{Diff}_c(-1, +1) \quad (\text{resp. } \widetilde{\text{Diff}}_+(\mathbf{S}^1))$$

(where \sim stands for the universal cover). For every loop γ in ∂B , we also refer to $\rho(\gamma)$ as the *monodromy* of the hole above γ . We call a standard hole *discal* if its base splits as a product $B = \mathbf{D}^2 \times X$, where X is a closed manifold.

Here are the relevant examples of standard holes, and their diagnostics.

- (i) In case ρ is extended by some representation

$$\bar{\rho} : \pi_1 B \rightarrow \text{Diff}_c(-1, +1) \text{ or } \widetilde{\text{Diff}}_+(\mathbf{S}^1)$$

then of course we fill H by the suspension of $\bar{\rho}$, and this filling is without interior leaves.

(ii) Every $\phi \in \text{Diff}_c(-1, +1)$ defines a 3-dimensional straight discal hole $\mathbf{D}^2 \times \mathbf{D}^1$ whose monodromy above $\partial \mathbf{D}^2$ is ϕ . By Reeb's global stability theorem, this standard hole *cannot* be filled unless ϕ is the identity.

(iii) More generally, consider a straight discal hole $\mathbf{D}^2 \times X \times \mathbf{D}^1$, where X is a closed manifold; the monodromy being trivial above $\pi_1 X$, and nontrivial above the loop $(\partial \mathbf{D}^2) \times *$, which is compressible in B . In other words, H is the X -stabilization (see 1.0.1) of example (ii). Then, by an easy generalization of Reeb's global stability theorem, H cannot be filled (exercise). Unfortunately, every hole H_i^n left by paragraph 3.2 falls to this case. Following Thurston, one will enlarge H_i^n by a worm gallery (see further down) and then be able to fill the enlarged hole.

(iv) Actually, the method to fill each enlarged H_i^n will be to divide it into smaller holes which will fall either to the suspension case (i) above, or to the two following ones.

VOCABULARY 3.2. Say that some subset of \mathbf{D}^1 *brackets* some other one, if they are disjoint and if every point of the second lies between two points of the first.

Let $r \geq 1$. Write $\mathbf{T}^r := (\mathbf{S}^1)^r$ for the r -torus. Given $r + 1$ commuting diffeomorphisms $\phi, \psi_1, \dots, \psi_r \in \text{Diff}_c(-1, +1)$, consider the $(r + 3)$ -dimensional straight discal hole

$$H := \mathbf{D}^2 \times \mathbf{T}^r \times \mathbf{D}^1$$

whose monodromy is ϕ over $\partial \mathbf{D}^2$ and ψ_k over the k -th \mathbf{S}^1 factor ($1 \leq k \leq r$).

LEMMA 3.3. (Filling the hole $\mathbf{D}^2 \times \mathbf{T}^r \times \mathbf{D}^1$) *Assume that:*

- (i) $\phi = [\alpha, \beta]$ is a commutator in $\text{Diff}_c(-1, +1)$;
- (ii) *The supports of ψ_1, \dots, ψ_r are pairwise disjoint, and their union brackets the supports of α and β .*

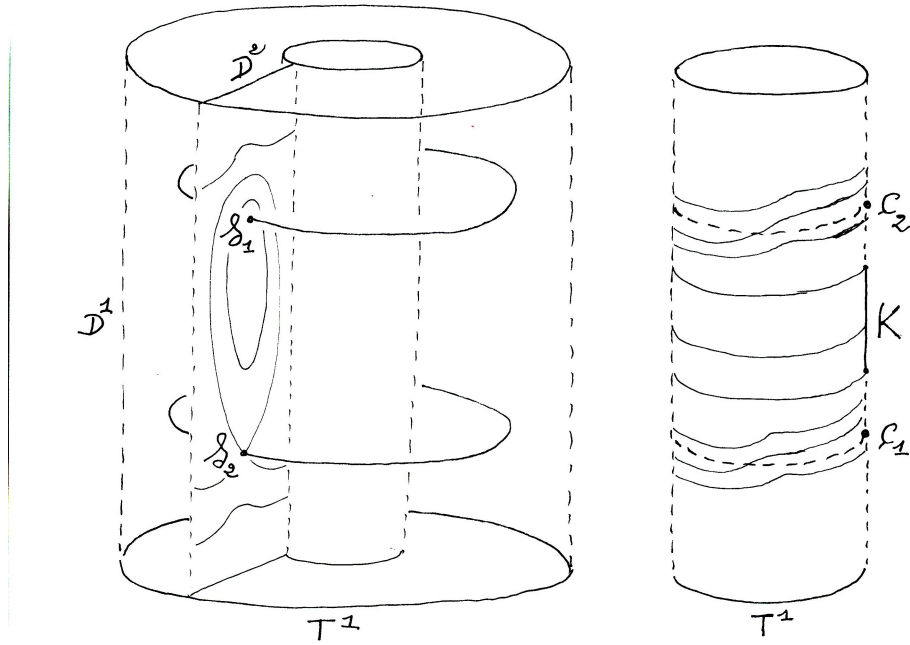

FIGURE 4. Filling a hole under a bracketting hypothesis. Here $r = 1$. The figure may be misleading because the slice $\mathbf{D}^2 \times \mathbf{D}^1$ has been represented as a rectangle; and the Morse function f in this slice, with its two singularities s_1, s_2 of respective indices 1 and 2 in cancellation position, has been represented as a Morse function on the rectangle with two singularities of respective indices 0 and 1 in cancellation position.

Then, H is fillable without interior leaves.

Except "without interior leaves", this is due to Thurston [19]. Our construction differs from his, in order to avoid to create interior compact leaves. We shall essentially need only the cases $r = 1, 2$.

Proof. (Figure 4) By condition (ii), there exist two points $-1 < c_1 < c_2 < +1$, neither of which is a common fixed point for ψ_1, \dots, ψ_r , and between which the supports of α and β lie. So, there is a finite union $K \subset (c_1, c_2)$ of compact subintervals such that the supports of α and β are contained in the interior of K , and the supports of ψ_1, \dots, ψ_r , in $\mathbf{D}^1 \setminus K$.

One endows the solid cylinder $\mathbf{D}^2 \times \mathbf{D}^1$ with the Morse function f obtained from the height function by creating two singularities $s_1 = (z_1, y_1)$, $s_2 = (z_2, y_2)$ of respective indices 1 and 2, in cancellation position. One arranges that $f(s_1) = c_1$ and $f(s_2) = c_2$. Stabilizing f by \mathbf{T}^r , one gets the mapping:

$$F : H = \mathbf{D}^2 \times \mathbf{T}^r \times \mathbf{D}^1 \rightarrow \mathbf{T}^r \times \mathbf{D}^1 : (z, \theta, y) \mapsto (\theta, f(z, y))$$

One endows $\mathbf{T}^r \times \mathbf{D}^1$ with the suspension $\mathcal{S}(\psi_1, \dots, \psi_r)$ of ψ_1, \dots, ψ_r . Since ψ_1, \dots, ψ_r are the identity on K , one can arrange that $\mathcal{S}(\psi_1, \dots, \psi_r)$ is the height foliation in restriction to $\mathbf{T}^r \times K$. Since c_1, c_2 are not common fixed points of ψ_1, \dots, ψ_r , one can arrange that $\mathcal{S}(\psi_1, \dots, \psi_r)$ is transverse to both tori $\mathbf{T}^r \times c_1$ and $\mathbf{T}^r \times c_2$ (the hypothesis that the supports of ψ_1, \dots, ψ_r are pairwise disjoint makes this point particularly immediate). Then, the mapping F is transverse to the foliation $\mathcal{S}(\psi_1, \dots, \psi_r)$. Indeed, F is a submersion, except on both tori $(z_1 \times \mathbf{T}^r \times y_1) \subset H$ and $(z_2 \times \mathbf{T}^r \times y_2) \subset H$, which F respectively maps diffeomorphically onto $\mathbf{T}^r \times c_1$ and $\mathbf{T}^r \times c_2$, both transverse to $\mathcal{S}(\psi_1, \dots, \psi_r)$. Consequently, $F^*(\mathcal{S}(\psi_1, \dots, \psi_r))$ is a (regular) foliation on H .

In $\mathbf{D}^2 \times \mathbf{D}^1$, the domain $f^{-1}(K)$ is diffeomorphic to the product of K with the compact orientable surface of genus one bounded by one circle. The fundamental group of this surface being non-abelian free on two generators, the suspension of α and β gives a foliation $\mathcal{S}(\alpha, \beta)$ of this domain.

The foliation \mathcal{F} filling H is defined as two pieces: in $F^{-1}(\mathbf{T}^r \times K)$ one takes the suspension $\mathcal{S}(\alpha, \beta)$ stabilized by the r -torus; and in the complement, \mathcal{F} is $F^*(\mathcal{S}(\psi_1, \dots, \psi_r))$. Obviously, \mathcal{F} fills the hole, i.e. coincides along ∂H with the given germ. Moreover, \mathcal{F} has no leaf interior to H . This is immediate in view of its trace on every 3-dimensional slice $\mathbf{D}^2 \times \theta \times \mathbf{D}^1$, for θ in \mathbf{T}^r . Every leaf of this trace, being either a level set of f or a leaf of the suspension $\mathcal{S}(\alpha, \beta)$, meets the boundary $(\partial \mathbf{D}^2) \times \theta \times \mathbf{D}^1$. \square

Lemma 3.3 has a round variant. To avoid irrelevant complications, we consider $\text{Diff}_+^*(\mathbf{S}^1)$, the group of the orientation-preserving diffeomorphisms of the circle fixing the basepoint. Its virtue is to be contained both in $\text{Diff}_+(\mathbf{S}^1)$ and in $\widetilde{\text{Diff}}_+(\mathbf{S}^1)$. Given $r+1$ diffeomorphisms $\phi, \psi_1, \dots, \psi_r \in \text{Diff}_+^*(\mathbf{S}^1)$, consider the $(r+3)$ -dimensional discal hole

$$H := \mathbf{D}^2 \times \mathbf{T}^r \times \mathbf{S}^1$$

whose monodromy is ϕ over $\partial \mathbf{D}^2$ and ψ_k over the k -th \mathbf{S}^1 factor ($1 \leq k \leq r$).

LEMMA 3.4. (Filling the hole $\mathbf{D}^2 \times \mathbf{T}^r \times \mathbf{S}^1$) *Assume that:*

- (i) $\phi = [\alpha, \beta]$ is a commutator in $\text{Diff}_+^*(\mathbf{S}^1)$;
- (ii) The supports of ψ_1, \dots, ψ_r are pairwise disjoint, and their union is nonempty and disjoint from the supports of α and β .

Then, H is fillable without interior leaves.

Proof. Much like in the straight case. By condition (ii), there exists a finite union $K \subset \mathbf{S}^1$ of compact subintervals such that the supports of α and β are contained in the interior of K , and the supports of ψ_1, \dots, ψ_r , in $\mathbf{S}^1 \setminus K$. By (ii) there are two points c_1, c_2 on \mathbf{S}^1 , both not common fixed points of ψ_1, \dots, ψ_r , and which lie in a same connected component of $\mathbf{S}^1 \setminus K$. Arrange that $c_2 < c_1$ in this interval endowed with the orientation induced from \mathbf{S}^1 .

One endows the solid torus $\mathbf{D}^2 \times \mathbf{S}^1$ with the \mathbf{S}^1 -valued Morse function f , obtained from the height function, that is, the second projection, by creating two singularities s_1, s_2 of respective indices 1 and 2, in cancellation position. One arranges that $f(s_1) = c_1$ and $f(s_2) = c_2$. The level set $f^{-1}(y)$ has genus 1 (resp. 0) in case y lies in the connected component of $\mathbf{S}^1 \setminus \{c_1, c_2\}$ containing (resp. not containing) K .

Just as in the straight case, F being the r -torus-stabilization of f , we fill $F^{-1}(\mathbf{T}^r \times K)$ by the r -torus-stabilized suspension of α and β ; and we fill the complement by the suspension of ψ_1, \dots, ψ_r pulled back through F . \square

Now, let us come back to the construction of a minimal foliation on M . The cancellation of the singularities (paragraph 3.2) has left a minimal foliation ξ_{hol} with some standard, discal holes of the form $H_i^n \cong \mathbf{D}^2 \times \Sigma \times \mathbf{D}^1$, where $1 \leq i \leq n-2$ and $\Sigma = \mathbf{S}^{n-i-2} \times \mathbf{S}^{i-1}$. The monodromy is $\phi \neq \text{id}$ over $\partial \mathbf{D}^2$ (*compressible monodromy*), and the identity over any loop in Σ . As already mentioned, H_i^n is *never* fillable.

However, ξ_{hol} being minimal, the complement M_{hol} of the holes in M contains an embedded arc joining the ceiling $\mathbf{D}^2 \times \Sigma \times (+1)$ of H_i^n to its floor $\mathbf{D}^2 \times \Sigma \times (-1)$, transversely to ξ_{hol} (*worm path*). One enlarges H_i^n by a small tubular neighborhood $W \cong \mathbf{D}^{n-1} \times \mathbf{D}^1$ of this arc (*worm gallery*), obtaining a new hole $H_i^n \cup W$. Its germ of foliation along the portion $\mathbf{S}^{n-2} \times \mathbf{D}^1$ of its boundary, the one that bounds W , is of course the height foliation. Actually, in the *sub-extremal* cases $i = 1$ or $n-2$, the hole not being connected, we add *two* disjoint worm galleries: one to each of the two connected components.

PROPOSITION 3.5. *Let $n \geq 4$, and $1 \leq i \leq n-2$, and $\phi \in \text{Diff}_c(-1, +1)$. Then the hole H_i^n whose compressible monodromy is ϕ , enlarged by a*

worm gallery (or by two worm galleries in case $i = 1$ or $n - 2$) is fillable without interior leaf.

Thurston fills the same holes with some kind of Reeb components inside [19]. We shall prove Proposition 3.5 in case ϕ is a commutator $[\alpha_0, \beta_0]$ in $\text{Diff}_c(-1, +1)$.

On the one hand, this case is enough to complete the proof of theorem A: in the whirl previous to the cancellation of each pair of matched singularities (3.2), take care to choose for ϕ a commutator in $\text{Diff}_c(-1, +1)$. Write M_{HOLED} for M minus the enlarged holes, and ξ_{HOLED} for $\xi|_{M_{\text{HOLED}}}$, an obviously minimal foliation. Applying 3.5, extend ξ_{HOLED} inside each enlarged hole, obtaining a foliation \mathcal{F} on M . By the last words of Proposition 3.5, every leaf of \mathcal{F} meets M_{HOLED} , so its closure contains M_{HOLED} . Every leaf being locally dense, every leaf is dense in M .

On the other hand, our argument generalizes straightforwardly for a product of commutators, and thus actually proves Proposition 3.5 in all cases, since $\text{Diff}_c^\infty(\mathbf{R})$ is perfect (Mather [13], using previous results by Epstein [2] and Herman [6][7][8]; see also [3]). But we don't need to use this "nonelementary background about groups of diffeomorphisms".

3.3.1. *First proof of Proposition 3.5 in dimension 4.* In dimension $n = 4$ there are two possible indices, $i = 1$ or 2 . The holes H_1^4 and H_2^4 being isomorphic by reversing the co-orientation of the foliation, we consider the case $i = 1$. Let H^4 be one of the two connected components of H_1^4 . So, $H^4 \cong \mathbf{D}^2 \times \mathbf{S}^1 \times \mathbf{D}^1$ is a straight discal hole whose base B is the solid torus $\mathbf{D}^2 \times \mathbf{S}^1$. Note that Lemma 3.3 does *not* apply directly to H^4 , since the monodromy over the second factor \mathbf{S}^1 is trivial: its support does not bracket the support of ϕ . Following Thurston, we shall subdivide H^4 into subholes with *more* monodromy (Figure 5). Consider in B the core $V_0 := 0 \times \mathbf{S}^1$, and

$$V_1 := \{z \in \mathbf{D}^2 / |z| = 1/2\} \times 1$$

(recall that \mathbf{D}^2 is the unit disk in \mathbf{C} and that 1 is the basepoint on \mathbf{S}^1 ; in other words, V_1 is the meridian of V_0); and we split B into three domains: two disjoint small compact tubular neighborhoods N_0, N_1 of V_0, V_1 ; and the complement $C := B \setminus \text{Int}(N_0 \cup N_1)$. In the base, V_0 bounds, modulo ∂B , the annulus $W_0 := [0, 1] \times \mathbf{S}^1$; while V_1 bounds the 2-disk

$$W_1 := \{z \in \mathbf{D}^2 / |z| \leq 1/2\} \times 1$$

which meets V_0 at its center.

Recall that ϕ is a commutator $[\alpha_0, \beta_0]$ in $\text{Diff}_c(-1, +1)$, and choose some α_1, β_1 in $\text{Diff}_c(-1, +1)$ whose supports are disjoint from those of

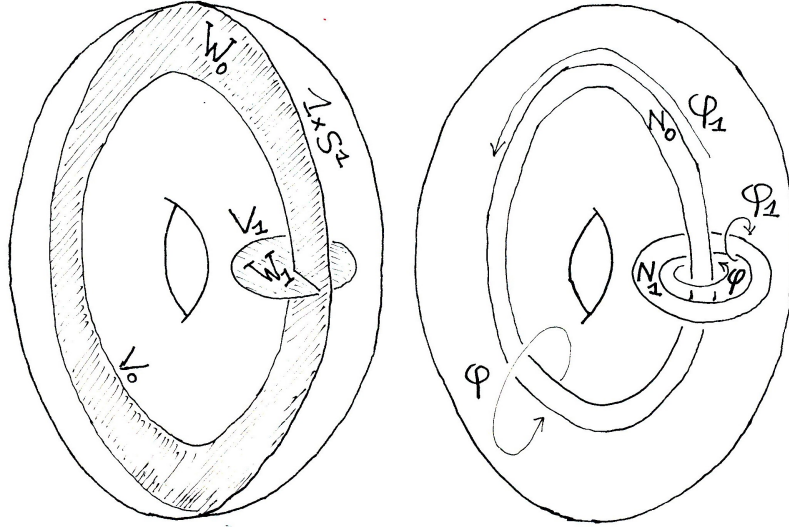

FIGURE 5. Splitting of the base B of the hole H^4 , and definition of the representation ρ . The monodromy over a few loops is indicated.

α_0, β_0 , and such that the support of $\phi_1 := [\alpha_1, \beta_1]$ brackets those of α_0, β_0 (see before Lemma 3.3). In particular, ϕ_1 commutes with ϕ . One fills up $C \times \mathbf{D}^1$ with the suspension of the representation

$$\rho : \pi_1 C \rightarrow \text{Diff}_c(-1, +1) : \gamma \mapsto \phi^{(W_0^* \gamma)} \phi_1^{(W_1^* \gamma)}$$

where $W_j^* \gamma$ denotes of course the algebraic intersection number between the loop γ and the hypersurface W_j . Obviously, ρ represents $\pi_1(\partial B)$ as needed: $\rho(\partial \mathbf{D}^2 \times 1) = \phi$ and $\rho(1 \times \mathbf{S}^1) = \text{id}$. It remains to fill the two discal sub-holes $N_0 \times \mathbf{D}^1$ and $N_1 \times \mathbf{D}^1$ (union a worm gallery).

In restriction to $\partial N_0 \cong (\partial \mathbf{D}^2) \times \mathbf{S}^1$, the representation ρ associates ϕ to the factor $\partial \mathbf{D}^2$, compressible in N_0 ; and ϕ_1 to the factor \mathbf{S}^1 ,

incompressible in N_0 . Since the support of ϕ_1 brackets those of α_0, β_0 , Lemma 3.3 applies, here $r = 1$, and fills the sub-hole $N_0 \times \mathbf{D}^1$.

On the other hand, in restriction to $\partial N_1 \cong (\partial \mathbf{D}^2) \times \mathbf{S}^1$, the representation ρ associates ϕ_1 to the factor $\partial \mathbf{D}^2$, compressible in N_1 ; and ϕ to the factor \mathbf{S}^1 , incompressible in N_1 . So, Lemma 3.3 *does not* apply to $N_1 \times \mathbf{D}^1$.

But remember the worm gallery W (Figure 6). The sub-torus N_1 is *inessential* in B , in the sense that N_1 is contained in a 3-ball D embedded into the base. After an isotopy in H^4 , one can assume that $D \times \pm 1$ coincide with the entrance and the exit of the gallery. We extend the hole $N_1 \times \mathbf{D}^1$ through W , obtaining an extended round hole $H_{\text{rnd}} \cong N_1 \times \mathbf{S}^1$. We keep the remainder of W filled with the height foliation, and so, the germ of foliation along ∂H_{rnd} is the suspension of two commuting diffeomorphisms $\bar{\phi}, \bar{\phi}_1$ of the circle. Here \mathbf{D}^1 is regarded as embedded into \mathbf{S}^1 and, for every $\psi \in \text{Diff}_c(-1, +1)$, one denotes by $\bar{\psi} \in \text{Diff}_+^*(\mathbf{S}^1)$ its extension by the identity. So, $\bar{\phi}_1 = [\bar{\alpha}_1, \bar{\beta}_1]$. Lemma 3.4 applies to the round hole $N_1 \times \mathbf{S}^1$, and fills it, taking $r = 1$, taking $\bar{\phi}_1$ for ϕ , and taking $\bar{\phi}$ for ψ_1 .

Obviously, no interior leaf has been created in $H^4 \cup W$. The first proof of Proposition 3.5 in dimension 4 is complete.

3.3.2. Proof of Proposition 3.5 for the almost extremal indices. The preceding 4-dimensional construction is a pattern for the proof of Proposition 3.5 in all dimensions $n \geq 4$. The generalization is more direct in the case where the index of the hole is almost extremal: $i = 1$ or $n - 2$. The hole H_{n-2}^n being isomorphic to H_1^n , we consider H_1^n . Let H^n be one of the two connected components of H_1^n , thus a straight discal hole whose base is $B := \mathbf{D}^2 \times \mathbf{S}^{n-3}$.

LEMMA 3.6. *For every $k \geq 0$, there is an embedding*

$$e_k : \mathbf{S}^k \times \mathbf{S}^1 \rightarrow \text{Int}(\mathbf{D}^1 \times \mathbf{S}^{k+1})$$

such that the mapping $pr_2 \circ e_k : \mathbf{S}^k \times \mathbf{S}^1 \rightarrow \mathbf{S}^{k+1}$ is of degree one.

Proof. One embeds $\mathbf{S}^k \times \mathbf{S}^1$ into \mathbf{S}^{k+2} as the boundary of a tubular neighborhood of a circle. One regards $\mathbf{D}^1 \times \mathbf{S}^{k+1}$ as the complement, in \mathbf{S}^{k+2} , of two small $(k+2)$ -balls, one interior to this neighborhood, the other exterior to this neighborhood. \square

Here, we depart from [19], where an analogous lemma is used, except that the $(k+1)$ -torus appears instead of $\mathbf{S}^k \times \mathbf{S}^1$. (For the present purpose, the difference is anecdotal; but it will become critical in section 4).

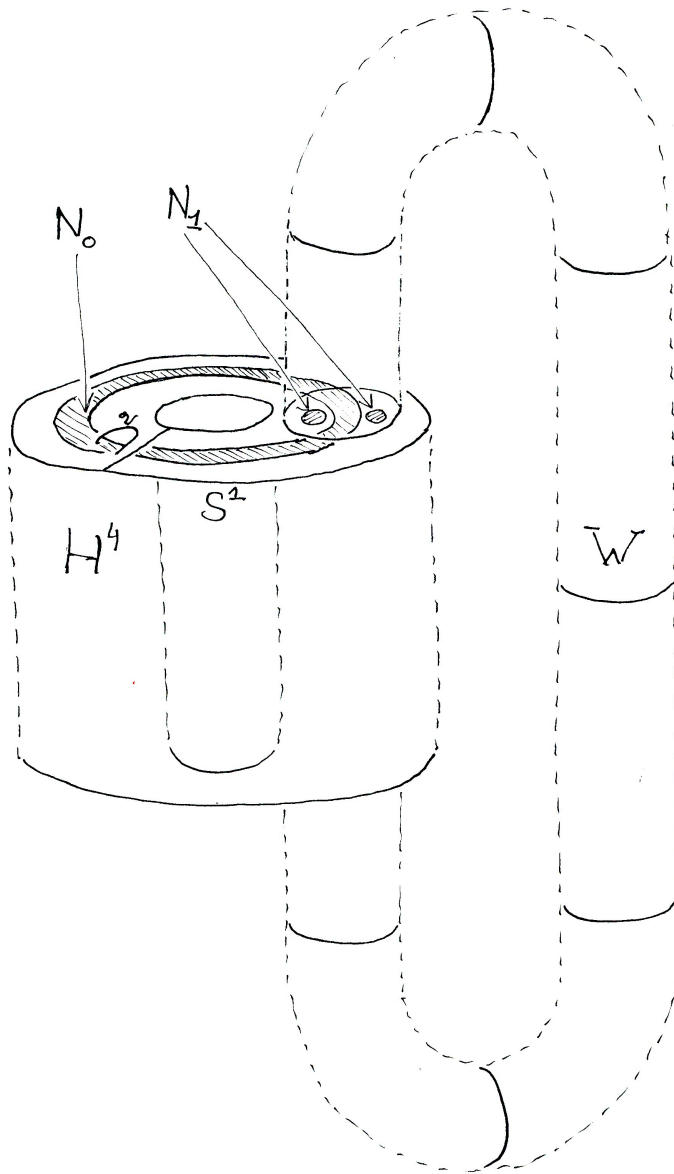

FIGURE 6. The hole H^4 and its worm gallery. The dimension reduction may be misleading here, because we have figured the solid torus $N_0 \cong \mathbf{D}^2 \times \mathbf{S}^1$ as the annulus $\mathbf{D}^1 \times \mathbf{S}^1$, and the solid torus $N_1 \cong \mathbf{D}^2 \times \mathbf{S}^1$ as two disks, $\mathbf{D}^2 \times \mathbf{S}^0$.

Now, we begin to fill H^n . Write $V := \mathbf{S}^{n-4} \times \mathbf{S}^1$ and let $j_0 : V \rightarrow B$ be e_{n-4} followed by the canonical inclusion $\mathbf{D}^1 \times \mathbf{S}^{n-3} \subset \mathbf{D}^2 \times \mathbf{S}^{n-3}$. Put $V_0 := j_0(V)$. The mapping

$$pr_2 \circ j_0 : V \rightarrow \mathbf{S}^{n-3}$$

being of degree one, V_0 together with $1 \times \mathbf{S}^{n-3}$ bound an orientable compact hypersurface W_0 in B (recall that 1 is the basepoint in $\partial\mathbf{D}^2$). Of course, the bundle normal to V_0 in B is trivial. One writes $X_0 := j_0(\mathbf{S}^{n-4} \times 1)$; one writes W_1 for the total space of the (trivial) \mathbf{D}^2 -bundle normal to V_0 above X_0 , so $W_1 \cong \mathbf{D}^2 \times \mathbf{S}^{n-4}$; one writes $V_1 := \partial W_1$; and one writes N_0, N_1 for two disjoint tubular neighborhoods of V_0, V_1 in the interior of B .

In $\mathbf{D}^1 \times \mathbf{S}^{n-3}$, the submanifold $e_{n-4}(\mathbf{S}^{n-4} \times 1)$ is inessential, i.e. contained in some ball: this is obvious from the proof of Lemma 3.6; alternatively, one can argue that in $\mathbf{D}^1 \times \mathbf{S}^{n-3}$, *every* submanifold of codimension two is inessential. So, X_0 is inessential in B . So, N_1 is also.

One continues the filling of H^n much as one did above (3.3.1) for H^4 : one assumes that $\phi = [\alpha_0, \beta_0]$ is a commutator; one chooses $\phi_1 = [\alpha_1, \beta_1]$ just as one did in 3.3.1; one fills $C \times \mathbf{D}^1$, where $C := B \setminus \text{Int}(N_0 \cup N_1)$, with the suspension of the representation ρ defined as in 3.3.1.

There remains to fill two discal subholes $N_0 \times \mathbf{D}^1, N_1 \times \mathbf{D}^1$.

The first one $N_0 \times \mathbf{D}^1$ is just the (\mathbf{S}^{n-4}) -stabilization of a 4-dimensional hole $\mathbf{D}^2 \times \mathbf{S}^1 \times \mathbf{D}^1$. Lemma 3.3, with $r = 1$, applies to this 4-dimensional hole and fills it with a foliation, whose (\mathbf{S}^{n-4}) -stabilization fills $N_0 \times \mathbf{D}^1$.

The second discal subhole $N_1 \times \mathbf{D}^1$ is first extended, since N_1 is inessential in B , through the worm gallery. One obtains a round hole $N_1 \times \mathbf{S}^1$, which is just the (\mathbf{S}^{n-4}) -stabilization of a 4-dimensional hole $\mathbf{D}^2 \times \mathbf{S}^1 \times \mathbf{S}^1$. Lemma 3.4, with $r = 1$, applies to this 4-dimensional hole and fills it with a foliation, whose (\mathbf{S}^{n-4}) -stabilization fills $N_1 \times \mathbf{S}^1$.

This completes the proof of Proposition 3.5 in every dimension $n \geq 4$, in case $i = 1$ or $n - 2$. In dimension 4, this second proof of Proposition 3.5 will be the right one for the concordance argument in the next section.

3.3.3. Proof of Proposition 3.5 for the intermediate indices. In case $n \geq 5$ and $2 \leq i \leq n - 3$, the base factor $\Sigma = \mathbf{S}^{n-i-2} \times \mathbf{S}^{i-1}$ is a product of two spheres of positive dimensions. (The author suggests to think to the simplest case $n = 5, i = 2$). Unfortunately, there exists, of course, no closed $(n - 4)$ -manifold X which would admit some mapping

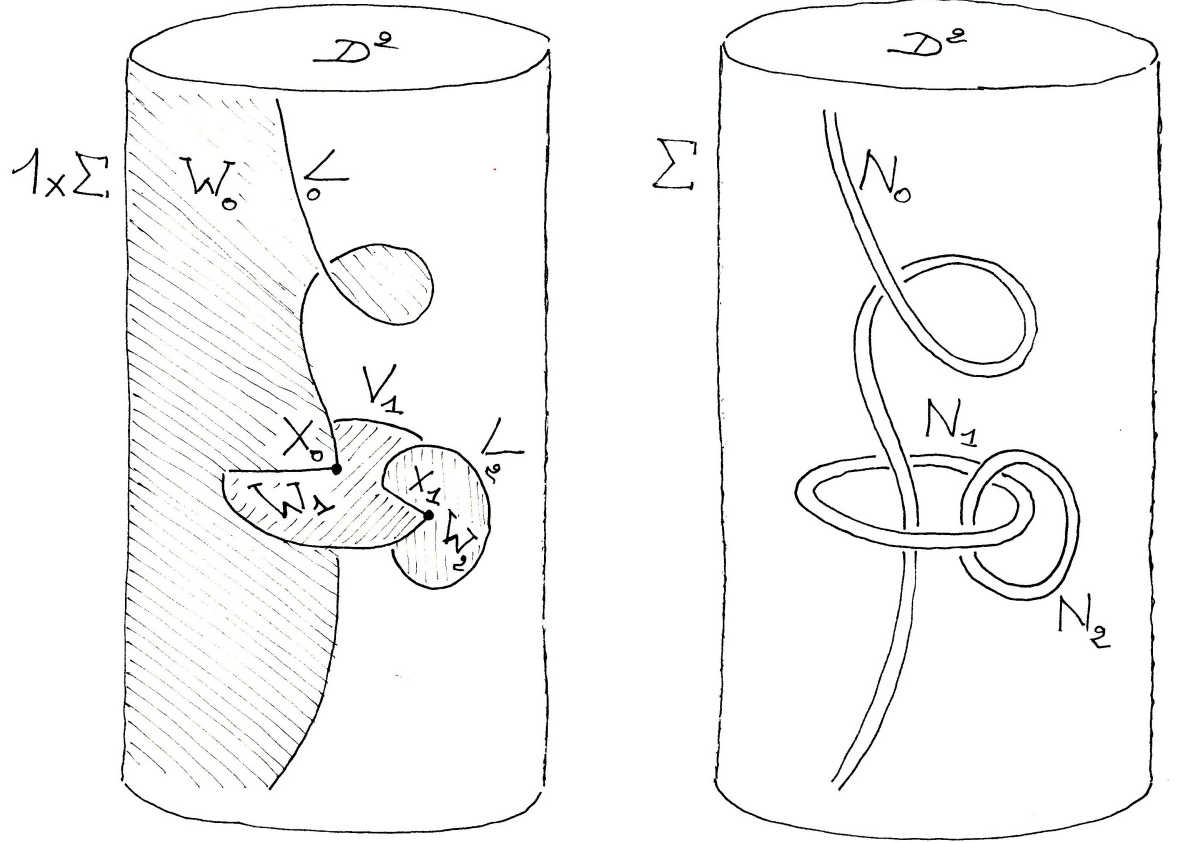

FIGURE 7. First *schematic* view on the “rolling up the holes” process. Here, the codimensions are respected; but, X_0 being reduced to one point, V_1 seems to be inessential in B , which it is not: we have to go to V_2 .

of nonzero degree

$$X \times \mathbf{S}^1 \rightarrow \mathbf{S}^{n-i-2} \times \mathbf{S}^{i-1}$$

that would be null-homotopic in restriction to $X \times 1$. We need one more iteration in the “rolling up” process: going somehow to the meridian of the meridian (Figures 7 and 8).

Consider the $(n-3)$ -manifold

$$V := \mathbf{S}^{n-i-3} \times \mathbf{S}^1 \times \mathbf{S}^{i-2} \times \mathbf{S}^1$$

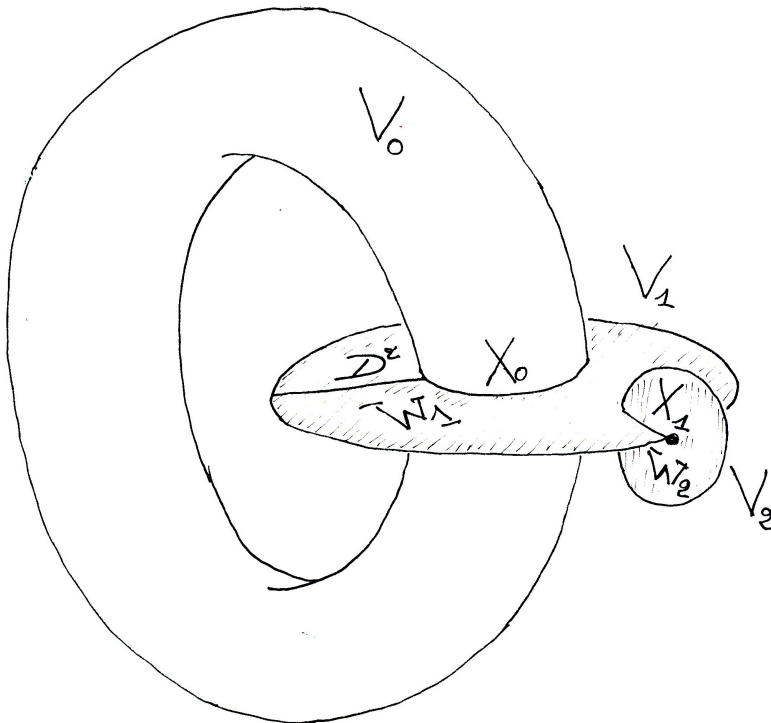

FIGURE 8. Second *schematic* view on the “rolling up the holes” process. In that figure, the codimensions are wrong. Note that, for $n = 5$ and $i = 2$, actually V_0 is a disjoint union of four 2-tori.

and the Cartesian product $j_0 := e_{n-i-3} \times e_{i-2}$ of the two embeddings given by Lemma 3.6:

$$j_0 : V \rightarrow \mathbf{D}^1 \times \mathbf{S}^{n-i-2} \times \mathbf{D}^1 \times \mathbf{S}^{i-1} \cong \mathbf{D}^2 \times \Sigma = B$$

Put $V_0 := j_0(V)$. The mapping $pr_2 \circ j_0 : V \rightarrow \Sigma$ being of degree one, V_0 together with $1 \times \Sigma$ bound an orientable compact hypersurface W_0 in B . Of course, the bundle normal to V_0 in B is trivial. One defines

$$X_0 := j_0(\mathbf{S}^{n-i-3} \times 1 \times \mathbf{S}^{i-2} \times \mathbf{S}^1)$$

and one defines W_1 as the total space above X_0 of the (trivial) \mathbf{D}^2 -bundle normal to V_0 in B . Let $V_1 := \partial W_1$ and choose a diffeomorphism $j_1 : V \rightarrow V_1$ such that the normal projection of every point $j_1(x_1, \theta_1, x_2, \theta_2)$ to V_0 is $j_0(x_1, 1, x_2, \theta_2)$. In the same way, one defines

$$X_1 := j_1(\mathbf{S}^{n-i-3} \times \mathbf{S}^1 \times \mathbf{S}^{i-2} \times 1)$$

and one defines W_2 as the total space over X_1 of the \mathbf{D}^2 -bundle normal to V_1 in B . Let $V_2 := \partial W_2$, a third embedding of V into the interior of B ; and let N_0, N_1, N_2 be pairwise disjoint, compact tubular neighborhoods of V_0, V_1, V_2 , respectively, in the interior of B .

This N_2 is inessential in B . Indeed, every submanifold of codimension 2 being inessential in the product of a sphere of positive dimension with an interval, the bisphere $j_0(\mathbf{S}^{n-i-3} \times 1 \times \mathbf{S}^{i-2} \times 1)$ is inessential in B . But clearly, shrinking the fibre 2-disks over X_0 and X_1 , one brings N_2 arbitrarily close to this bisphere through an isotopy in B .

One continues the filling of H_i^n ($2 \leq i \leq n-3$) much as one did above in the case $i = 1, n-2$. In $\text{Diff}_c(-1, +1)$, some diffeomorphisms $\alpha_j, \beta_j, \phi_j$ ($0 \leq j \leq 2$) are chosen such that:

- $\phi_0 = \phi$;
- Each $\phi_j = [\alpha_j, \beta_j]$;
- For all $j \neq k$, the supports of α_j, β_j are disjoint from those of α_k, β_k ;
- For every $j \geq 1$, the support of ϕ_j brackets those of α_{j-1} and β_{j-1} .

One writes

$$C := B \setminus \text{Int}(N_0 \cup N_1 \cup N_2)$$

and fills the sub-hole $C \times \mathbf{D}^1$ by the suspension of the representation

$$\rho : \gamma \mapsto \phi_0^{(W_0^* \gamma)} \phi_1^{(W_1^* \gamma)} \phi_2^{(W_2^* \gamma)}$$

It remains to fill the sub-holes $N_0 \times \mathbf{D}^1$, $N_1 \times \mathbf{D}^1$ and $N_2 \times \mathbf{D}^1$.

The first one is the stabilization by $X := \mathbf{S}^{n-i-3} \times \mathbf{S}^{i-2} \times \mathbf{S}^1$ of a 4-dimensional hole $\mathbf{D}^2 \times \mathbf{S}^1 \times \mathbf{D}^1$, whose monodromy is ϕ_0 over $\partial \mathbf{D}^2$ and ϕ_1 over the incompressible \mathbf{S}^1 factor. Lemma 3.3 (with $r = 1$) applies to $\mathbf{D}^2 \times \mathbf{S}^1 \times \mathbf{D}^1$ and fills it with a foliation, whose X -stabilization fills $N_0 \times \mathbf{D}^1$.

The second hole $N_1 \times \mathbf{D}^1$ is the $(\mathbf{S}^{n-i-3} \times \mathbf{S}^{i-2})$ -stabilization of a 5-dimensional hole $\mathbf{D}^2 \times \mathbf{T}^2 \times \mathbf{D}^1$, whose monodromy is ϕ_1 over $\partial \mathbf{D}^2$ and ϕ_0, ϕ_2 over the two incompressible \mathbf{S}^1 factors. Lemma 3.3 (with $r = 2$) applies to $\mathbf{D}^2 \times \mathbf{T}^2 \times \mathbf{D}^1$ and fills it with a foliation, whose $(\mathbf{S}^{n-i-3} \times \mathbf{S}^{i-2})$ -stabilization fills $N_1 \times \mathbf{D}^1$.

The third hole $N_2 \times \mathbf{D}^1$ is the X -stabilization of a 4-dimensional hole $\mathbf{D}^2 \times \mathbf{S}^1 \times \mathbf{D}^1$, whose monodromy is ϕ_2 over $\partial\mathbf{D}^2$ and ϕ_1 over the incompressible \mathbf{S}^1 factor. Since N_2 is inessential in B , one can extend this hole through the worm gallery, and one obtains a round hole $N_2 \times \mathbf{S}^1$, which is just the X -stabilization of a 4-dimensional round hole $\mathbf{D}^2 \times \mathbf{S}^1 \times \mathbf{S}^1$. Lemma 3.4 (with $r = 1$) applies to $\mathbf{D}^2 \times \mathbf{S}^1 \times \mathbf{S}^1$ and fills it with a foliation, whose X -stabilization fills $N_2 \times \mathbf{S}^1$. This completes the proof of Proposition 3.5 in the case $n \geq 5$ and $2 \leq i \leq n - 3$, and the construction of a minimal foliation on M .

4. PRESCRIBING THE CONCORDANCE CLASS OF THE FOLIATION AS A Γ_1 -STRUCTURE.

In this section, one more step is made towards Theorem A. We are given a closed connected manifold M of dimension $n \geq 4$ whose Euler characteristic is zero; and, on this manifold, a smooth, co-oriented Γ_1 -structure ξ . We build a concordance from ξ to some minimal foliation; that is, a Γ_1 -structure η on $\bar{M} := M \times [0, 1]$ such that $\eta|(M \times 0) = \xi$ and that $\eta|(M \times 1)$ is regular and minimal. Actually, we shall verify that the method used in the preceding section, with some extra care, builds such a concordance.

By a *Morsifying concordance*, we mean of course a Γ_1 -structure η on \bar{M} such that $\eta|(M \times 0) = \xi$ and that $\eta_1 := \eta|(M \times 1)$ is Morse. Call every $s \in M \times 1$ which is singular for η_1 , a *boundary singularity*. The *index* of s will always mean its Morse index in $M \times 1$. Call s a *positive* (resp. *negative*) *half Morse singularity* of η , if \bar{M} admits at s some local coordinates $x_0 = 1 - \text{pr}_2, x_1, \dots, x_n$, w.r.t. which η is defined by the quadratic form

$$(\text{sign})x_0^2 - x_1^2 - \dots - x_i^2 + x_{i+1}^2 + \dots + x_n^2$$

where $\text{sign} = +1$ (resp. -1).

It is immediate to make a first Morsifying concordance: start from the pullback Γ_1 -structure $\text{pr}_1^*(\xi)$ on \bar{M} , and recall that it is the germ, along $\bar{M} \times 0$ in $\bar{M} \times \mathbf{R}$, of some foliation \mathcal{X} , defined on some open neighborhood U of $M \times 0$ in $M \times \mathbf{R}$, and transverse to the \mathbf{R} -fibres. For a generic smooth section $\sigma : \bar{M} \rightarrow U$ which is zero over $M \times 0$, the restriction $\sigma|(M \times 1)$ has only quadratic tangencies with \mathcal{X} . Take $\eta := \sigma^*(\mathcal{X})$. Note that generically, the boundary singularities of η are *not* half Morse singularities. However, it is easy to make them such, after a perturbation of η supported in a small neighborhood of s , and relative to $M \times 1$. The sign can be chosen arbitrarily.

Now, we make $\eta|(M \times 1)$ regular and minimal through the same successive transformations as in the section 3. We have to verify, for each transformation, that it extends to the concordance. This will follow from some *inductive extension* property of the transformation: it can be extended from $M \times 1$ to $M \times [0, 1]$, relatively to $M \times 0$, by one half of the same transformation performed in dimension $n + 1$. In fact, this property will always come from a sequence of models to which the transformation is conjugate through some local chart. One will have a minimal dimension n_0 and, for every $n \geq n_0$, a model space E^n of dimension n endowed with two model Γ_1 -structures ϵ^n, ϵ'^n (maybe with holes), such that $E^n \subset E^{n+1}$ is a separating hypersurface, that $\epsilon^n = \epsilon'^{n+1}|E^n$, and that $\epsilon'^n = \epsilon'^{n+1}|E^n$ (*induction* property). The transformation consists in changing the original structure ϵ^n to the final structure ϵ'^n .

In the remaining of this section, we verify that the transformations used in the section 3 are inductively extendable. We shall content ourselves with pointing the main points; some do deserve some care. We begin with the creation and cancellation tools, before passing to the process used in the section 3 itself.

Write $\frac{1}{2}\mathbf{D}^{k+1}$ for the compact half unit $(k + 1)$ -disk, defined in \mathbf{R}^{k+1} by $x_0^2 + \cdots + x_k^2 \leq 1$ and $x_0 \geq 0$; write $\frac{1}{2}\mathbf{S}^k$ for the compact half unit k -sphere, defined in \mathbf{R}^{k+1} by $x_0^2 + \cdots + x_k^2 = 1$ and $x_0 \geq 0$. So, $\partial(\frac{1}{2}\mathbf{D}^{k+1}) = \frac{1}{2}\mathbf{S}^k \cup \mathbf{D}^k$.

4.0.1. *Creation of a pair of singularities.* The creation of a pair of Morse singularities s, s' , of respective indices i and $i + 1$, is inductively extendable. One creates two *positive* half Morse singularities of the concordance. The model is defined in every dimension $n \geq n_0 := i + 1$. The model n -space is $E^n := \mathbf{R}^n$. Here, \mathbf{R}^n is included in \mathbf{R}^{n+1} as the hyperplane $x_{i+1} = 0$. The two model Γ_1 -structures ϵ^n, ϵ'^n are defined respectively by the functions x_n and $f_i \circ F_i^{-1}$ of Example 2.2, (2). The induction property is immediately verified on the formulas of Example 2.2, (2).

4.0.2. *Cancellation of a pair of singularities.* The cancellation of a pair of Morse singularities s, s' , of respective indices i and $i + 1$, is inductively extendable. The model is defined in every dimension $n \geq n_0 := i + 1$. The model n -space is $E^n := \mathbf{R}^n$. Here, \mathbf{R}^n is included in \mathbf{R}^{n+1} as the hyperplane $x_{i+1} = 0$. The original model Γ_1 -structure ϵ^n is defined by the function $f_i \circ F_i^{-1}$ of Example 2.2, (2). The final model Γ_1 -structure ϵ'^n is given by Lemma 2.3: it is defined by the function $f_i \circ F_i^{-1}$, except on some small neighborhood N of the cancellation disks, where it is

defined by g . The induction property is verified throughout the proof of this lemma: the point is that we can choose the pseudogradient ∇ and the isotopy $\bar{\phi}_h$ to be tangential to the hyperplane $x_{i+1} = 0$. With this choice, the function induced by g on this hyperplane is also noncritical (and every connected component of every level set of the induced function in N , meets ∂N).

To cancel a pair of boundary singularities, the hypotheses are as follows. In \bar{M} , let η be a Morsifying concordance; let s, s' be a pair of boundary singularities, whose respective indices in $M \times 1$ are i and $i + 1$. Assume that s is a positive half Morse singularity of η . At s , define a *half stable* $(n - i + 1)$ -disk as the image of an embedding $F : \frac{1}{2}\mathbf{D}^{n-i+1} \rightarrow \bar{M}$, such that $F(0) = s$, that $F^{-1}(M \times 1) = \mathbf{D}^{n-i}$, and that $F^*\eta = \xi_{\text{can}}^{n-i+1}|_{\frac{1}{2}\mathbf{D}^{n-i+1}}$ (compare Definition 2.6).

Assume that η admits at s a half stable $(n - i + 1)$ -disk $\frac{1}{2}\mathcal{D}^s$. Assume that η admits at s' an unstable $(i + 1)$ -disk \mathcal{D}^u , contained in $M \times 1$. Assume that $\mathcal{D}^u \cap \frac{1}{2}\mathcal{D}^s$ is a single point $x \in M \times 1$, at which the attachment spheres $\partial\mathcal{D}^u$ and $\partial(\frac{1}{2}\mathcal{D}^s \cap (M \times 1))$ meet transversely in the leaf of $\eta|(M \times 1)$ through x .

The cancellation itself is as follows. Write

$$\frac{1}{2}\mathbf{R}^{n+1} := \{(x_1, \dots, x_{n+1}) \in \mathbf{R}^{n+1} / x_{i+1} \geq 0\}$$

Turn s' into a positive half Morse singularity of η . Then, using the relative Morse lemma (see 2.1) at s' , and another relative form of the Morse lemma at s (exercise), one makes, on a neighborhood of $\frac{1}{2}\mathcal{D}^s \cup \mathcal{D}^u$ in \bar{M} , a local conjugation of η with $\epsilon^{n+1}|_{\frac{1}{2}\mathbf{R}^{n+1}}$, such that the two stable half disks match, and the two unstable disks match. One changes η , close to $\frac{1}{2}\mathcal{D}^s \cup \mathcal{D}^u$, to the preimage of $\epsilon^{n+1}|_{\frac{1}{2}\mathbf{R}^{n+1}}$ through the local conjugation.

4.0.3. Replacement of a local extremum. The replacement of a singularity s of index 0 (resp. n) by one of index 2 (resp. $n - 2$) and a Reeb component, as in paragraph 3.1, is defined in every dimension $n \geq 3$, and inductively extendable. This follows easily from 4.0.1 and 4.0.2. First, one turns the boundary singularity s into a positive (resp. negative) half Morse singularity of the concordance η ; in other words, η admits at s a small half stable (resp. unstable) $(n + 1)$ -disk; then, one creates close to s a pair of positive (resp. negative) boundary singularities s', s'' of indices 1 and 2 (resp. $n - 1$ and $n - 2$); finally, one cancels s with s' . One is left with s'' and a half $(n + 1)$ -dimensional Reeb component.

4.0.4. *Minimization.* The minimization process of paragraph 3.1 is defined for every $n \geq 3$ and inductively extendable — as follows essentially from 4.0.1. The model n -space E^n is $\mathbf{D}^{n-1} \times \mathbf{D}^1$. The inclusion $E^n \subset E^{n+1}$ is the standard one. In E^{n+1} , one arranges that the four singularities s_1, s_2, s'_1, s'_2 of f , whose indices are respectively 1 and 2 and 1 and 2, lie in E^n , and that $f|_{E^n}$ be Morse with exactly the same singularities and the same indices. Then, the whirl is also inductive.

4.0.5. *Matching.* The creation, as in 3.2, of new pairs of singularities, until they match into pairs of successive indices, is of course inductively extendable, by 4.0.1.

4.0.6. *Whirl and holes.* In the paragraph 3.2, given two singularities of indices i and $i+1$, and at them two small, disjoint, stable and unstable disks, a whirl changed these disks into a cancellation pair, at the price of a hole. This whirl is defined for $n \geq i+2$; it is inductively extendable. Here, $E^n := \mathbf{R}^n$; the model Γ_1 -structures are the height Γ_1 -structure defined by $x_n = 0$, and the holed Γ_1 -structure described in 3.2. The inclusion $E^n \subset E^{n+1}$ is

$$\mathbf{R}^{n-i-1} \times \mathbf{R}^i \times \mathbf{R} \subset \mathbf{R}^{n-i} \times \mathbf{R}^i \times \mathbf{R}$$

Returning to this transformation in \bar{M} , some precision is necessary; and we describe the structure of the resulting hole.

One starts from a matched pair s, s' of boundary singularities of η , of indices $i, i+1$, with $1 \leq i \leq n-2$; and from a path from s to s' in $M \times 1$, positively transverse to η but at its endpoints.

The case $i = n-2$ must be avoided; the reason will appear in the next paragraph. In case $i = n-2$, we reverse the co-orientation of η to shift to the case $i = 1$. So, $1 \leq i \leq n-3$.

We make s and s' positive. Then, the whirl that gives them a cancellation pair, and their cancellation, are extended to \bar{M} by one half of the same transformation in dimension $n+1$. This leaves a nonfoliated *half hole*

$$\frac{1}{2}H_i^{n+1} \cong \mathbf{D}^2 \times \frac{1}{2}\mathbf{S}^{n-i-1} \times \mathbf{S}^{i-1} \times \mathbf{D}^1$$

whose intersection with $M \times 1$ is H_i^n (Figure 9).

4.0.7. *Worm galleries.* The enlargement of the holes is inductively extendable. Thanks to the minimality of $\eta|(M \times 1)$, one enlarges each connected component of each half hole $\frac{1}{2}H_i^{n+1}$ with a *half worm gallery* $\frac{1}{2}W^{n+1} \cong \frac{1}{2}\mathbf{D}^n \times \mathbf{D}^1$, whose intersection with $M \times 1$ is a worm gallery $W^n \cong \mathbf{D}^{n-1} \times \mathbf{D}^1$. (This is the point that would fail if one had allowed

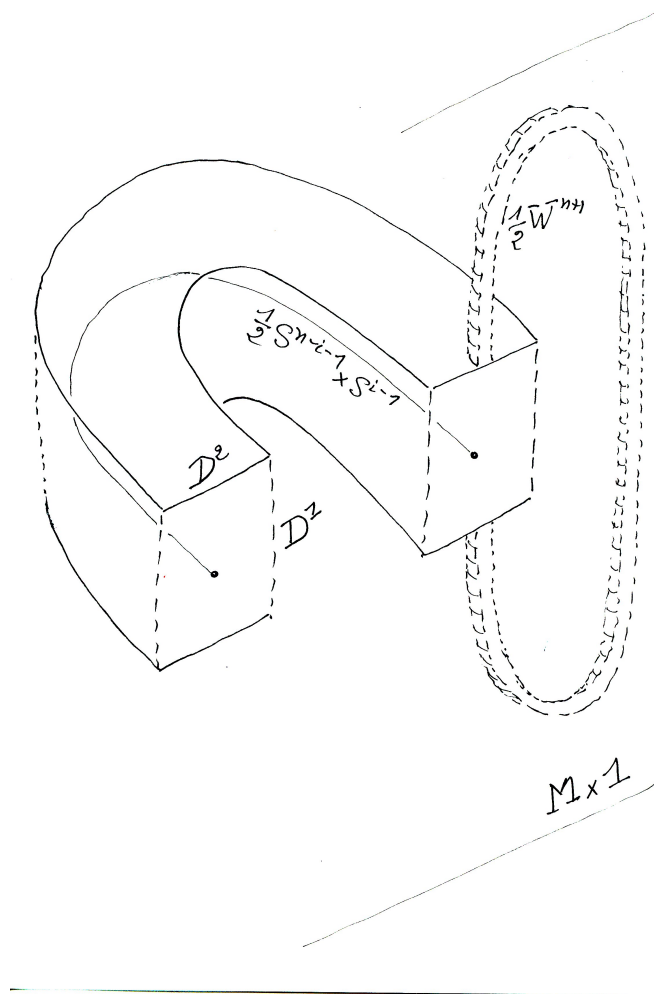

FIGURE 9. A half hole and its half worm gallery. This low-dimensional figure may be misleading because of the number of half worm galleries.

$i = n - 2$, since the number of galleries would not be the same for H_i^{n+1} and for H_i^n).

4.0.8. *Filling the holes.* It remains to fill the enlarged half holes, which amounts to verifying that the filling of the enlarged holes, performed in 3.3, is inductively extendable.

In the case $i = 1$, the model space E^n , defined for every $n \geq 4$, is

$$H_1^n \cup W^n = (\mathbf{D}^2 \times \mathbf{S}^{n-3} \times \mathbf{S}^0 \times \mathbf{D}^1) \cup (\mathbf{D}^{n-1} \times \mathbf{D}^1) \cup (\mathbf{D}^{n-1} \times \mathbf{D}^1)$$

The inclusion $E^n \subset E^{n+1}$ is induced by the standard inclusions $\mathbf{S}^{n-3} \subset \mathbf{S}^{n-2}$ and $\mathbf{D}^{n-1} \subset \mathbf{D}^n$.

In the case $i \geq 2$, the model space E^n , defined for every $n \geq i + 3$, is

$$H_i^n \cup W^n = (\mathbf{D}^2 \times \mathbf{S}^{n-i-2} \times \mathbf{S}^{i-1} \times \mathbf{D}^1) \cup (\mathbf{D}^{n-1} \times \mathbf{D}^1)$$

The inclusion $E^n \subset E^{n+1}$ is induced by the standard inclusions $\mathbf{S}^{n-i-2} \subset \mathbf{S}^{n-i-1}$ and $\mathbf{D}^{n-1} \subset \mathbf{D}^n$.

One has to verify that the filling of $H_i^{n+1} \cup W^{n+1}$ induces by restriction the filling of $H_i^n \cup W^n$.

The embedding Lemma 3.6 admits the following inductive version, whose proof is straightforward. Write the inductive limit of the spheres \mathbf{S}^k as \mathbf{S}^∞ .

LEMMA 4.1. *There is a mapping*

$$e : \mathbf{S}^\infty \times \mathbf{S}^1 \rightarrow \mathbf{D}^1 \times \mathbf{S}^\infty$$

such that

- (1) For each $k \geq 0$, the restriction $e_k := e|_{(\mathbf{S}^k \times \mathbf{S}^1)}$ is an embedding of $\mathbf{S}^k \times \mathbf{S}^1$ into $\text{Int}(\mathbf{D}^1 \times \mathbf{S}^{k+1})$;
- (2) For each $k \geq 0$, the composite $\text{pr}_2 e_k$ is a mapping of degree one from $\mathbf{S}^k \times \mathbf{S}^1$ onto \mathbf{S}^{k+1} .

Now we apply the filling process of paragraphs 3.3.2 and 3.3.3, using the embeddings e_k given by Lemma 4.1 (For $n = 4$ and $i = 1$, we don't apply paragraph 3.3.1, whose construction is not inductive; it is not clear whether this construction results in a concordance of Γ_1 -structures).

Almost extremal index — Consider the case $i = 1$, $n \geq 4$. Recall H^{n+1} , a connected component of H_1^{n+1} ; and its base $B^n \cong \mathbf{D}^2 \times \mathbf{S}^{n-2}$. Since e_{n-3} extends e_{n-4} , in B^n , one easily arranges that $V_0, W_0, X_0, W_1, V_1, N_0, N_1, C$ intersect the base $B^{n-1} \cong \mathbf{D}^2 \times \mathbf{S}^{n-3}$ of H^n along the analogous subsets. Then, the representation ρ and the filling of C are inductive. The filling of N_0 by means of a stabilization of Lemma 3.3 is obviously inductive: the induction carries simply on the stabilizing factors $\mathbf{S}^{n-4} \subset \mathbf{S}^{n-3}$. In the same way, N_1 being inessential in B^n and $N_1 \cap B^{n-1}$ being inessential in B^{n-1} , one chooses a half n -ball $\frac{1}{2}D^n \subset B^n$ containing N_1 , whose boundary intersects B^{n-1} along a $(n-1)$ -ball D^{n-1} . One takes $\frac{1}{2}D^n$ (resp. D^{n-1}) as the entrance and exit of the worm gallery attached to H^{n+1} (resp. H^n). Then, the extension of $N_1 \times \mathbf{D}^1$ through the gallery, by a round hole, is inductive. Its filling is inductive, for the same reasons as for N_0 . Thus, the filling of the enlarged holes of index 1 is inductive.

Intermediate index — In case $2 \leq i \leq n - 3$, completely similar arguments show that the filling of the enlarged holes of intermediate index is also inductive.

5. PRESCRIBING THE HOMOTOPY CLASS OF THE FOLIATION AS A HYPERPLANE FIELD.

In this section, we are given a closed connected manifold M of dimension $n \geq 4$; a co-oriented, Morse-singular, minimal Γ_1 -structure ξ on M ; and a nonsingular vector field V on M . We build a minimal foliation whose negative gradient is homotopic to V . We apply the same method as in the paragraphs 3.2 and 3.3, but we take more care in the choice of the cancellation disks and of the cancellation arcs, in order to control the homotopy class of the pseudogradients of the output foliation. The smooth (C^∞) differentiability class is understood everywhere. Obviously, this section is compatible with the preceding one, thus proving Theorem A.

5.1. Generalities on the opposition between a nonsingular vector field and a pseudogradient.

5.1.1. Definitions.

DEFINITION 5.1. A *pseudogradient* for ξ is a vector field ∇ on M such that:

- ∇ is negatively transverse to ξ , except at the singularities of ξ ;
- On some neighborhood of every singularity of ξ , the field ∇ is the negative gradient of some local first integral of ξ with respect to some *flat* local Riemannian metric.

One immediately makes a pseudo-gradient ∇ , using the Morse Lemma and a partition of the unity.

VOCABULARY 5.2. We call $x \in M$ an *opposition* point between V and ∇ , and write $x \in \mathcal{O}(V, \nabla)$, if $V(x)$ and $\nabla(x)$ are nonpositively colinear. Every singularity of ξ is an opposition point. We call x a *regular* opposition point, if moreover $x \notin \text{Sing}(\xi)$. We call x a *nondegenerate* opposition point, if moreover V and ∇ are transverse to each other at x , as sections of the projectivized tangent bundle. Then, $\mathcal{O}(V, \nabla)$ is a curve in a neighborhood of x .

At a regular opposition point x , let c be the real factor $V(x)/\nabla(x)$. The *opposition framing* $\mathcal{F}_x(V, \nabla)$ is the differential at x of the vector field $V - c\nabla$, modulo $\mathbf{R}\nabla(x)$. So, $\mathcal{F}_x(V, \nabla)$ is a linear morphism from $T_x M$ to $T_x M / \mathbf{R}\nabla(x) = T_x \xi$. Clearly, x is nondegenerate iff $\mathcal{F}_x(V, \nabla)$ is of maximal rank $n - 1$.

We call a regular opposition point x *noncubic* if $\mathcal{F}_x(V, \nabla)$ is of rank $n-1$ in restriction to $T_x\xi$. Then, x is nondegenerate; the curve $\mathcal{O}(V, \nabla)$ is transverse to ξ at x ; and $\mathcal{F}_x(V, \nabla)$ gets identified with a linear automorphism of $T_x\xi$. We also get an *opposition, Poincaré-Hopf index*: the sign of the Jacobian of this automorphism.

We call a regular opposition point x *hyperbolic* if $\mathcal{F}_x(V, \nabla)$ restricted to $T_x\xi$ induces a hyperbolic linear automorphism of $T_x\xi$. Then, x is noncubic; and $T_x\xi$ splits as the direct sum of the stable space $\mathcal{E}_x^s(V, \nabla)$ with the unstable space $\mathcal{E}_x^u(V, \nabla)$. We also get an *opposition, stability index*: the dimension of $\mathcal{E}_x^s(V, \nabla)$.

A nondegenerate opposition point which is a Morse singularity of $\xi|\mathcal{O}(V, \nabla)$ is called a *cusplike*. The Morse index is 0 or 1. At such a point, the Euler-Poincaré index changes.

Alternatively, we can view these properties in terms of the vector field X on $M \setminus \text{Sing}(\xi)$, projection of V on the leaves of ξ parallelly to ∇ . On some domain of $M \setminus \text{Sing}(\xi)$, let x_1, \dots, x_{n-1}, x_n be local coordinates such that ξ is defined by x_n . One thinks of X , in this domain, as a one-parameter family of vector fields on the plaques $x_n = \text{const}$, parametrized by x_n . Write L_x for the plaque through x . If x is an opposition point, then x is a singularity of $X|L_x$. The opposition point is noncubic (resp. hyperbolic) iff $X|L_x$ has a nondegenerate (resp. hyperbolic) singularity at x . Then, $\mathcal{F}_x(V, \nabla)$ is simply the differential of $X|L_x$ at x . At a cusplike of index 0 (resp. 1), in the one-parameter family X , one sees the birth or the death of a pair of nondegenerate singularities.

EXAMPLE 5.3. a) Given an index $1 \leq i \leq n-2$, recall the function P_i of Example 2.2. Consider the parallel vector field $U := -\partial/\partial x_n$, and the negative Euclidean gradient ∇P_i . Every regular opposition point between U and ∇P_i is hyperbolic.

Precisely, the opposition locus is the segment $[s, s']$. At every regular opposition point, the Lagrange multiplier $c := U/\nabla P_i$ equals $(3x_n^2 - 3)^{-1}$; the differential of $U - c\nabla P_i$ is diagonal; its eigenvalues being $-2c$ (with multiplicity i); $+2c$ (with multiplicity $n-i-1$); $2x_n(x_n^2 - 1)^{-1}$ (not relevant since its eigenvector is ∇P_i). Therefore, the opposition between U and ∇P_i is hyperbolic w.r.t. P_i ; the framing is positively proportional to $I_i \oplus -I_{n-i-1}$; the opposition index is $n-i-1$.

b) The same holds if we change P_i and ∇P_i for f_i and its negative Euclidean gradient ∇f_i : indeed, $\mathcal{O}(U, \nabla f_i) = [s, s']$, as follows from the observations made in Example 2.2 about the partial derivatives of f_i .

EXAMPLE 5.4. a) Given two indices $1 \leq i \leq n-2$, and $j = 0$ or 1 , recall the function P_i of Example 2.2. Consider the parallel vector field

$V_j := (-1)^{j+1} \partial/\partial x_1 - \partial/\partial x_n$, and the negative Euclidean gradient ∇P_i . Some straightforward computations give the following.

- The opposition locus between V_j and ∇P_i is an arc (of parabola) bounded by s and s' ;
- This arc is not tangent to the isotropic cones of $d^2 P_i$ at s , nor at s' ;
- Every regular opposition point is nondegenerate (precisely, for $c := V_j/\nabla_x f_i$, the endomorphism $D_x(V_j - c\nabla P_i) = c\text{Hess}_x P_i$, being diagonal with entries $\pm 2c, \dots, \pm 2c, 6cx_n$, is of rank $n-1$ modulo V_j);
- Every regular opposition point is noncubic, except one, which is a cusp of index j .

b) We claim that, for a good choice of the plateau function ϕ in Example 2.2, the same as a) holds for the function f_i and for the opposition between V_j and the negative Euclidean gradient ∇f_i .

Indeed, to the conditions given for r and ϕ in Example 2.2, add that $r^2 \geq 65$; that $\mathcal{O}(V_j, \nabla P_i) \subset B_r$; and that $0 \leq \phi' \leq 1/3$. We have to verify that every opposition point x between V_j and ∇f_i is of norm at most r .

By the equation (2) in Example 2.2, one has $x_2 = \dots = x_{n-1} = 0$. Also, $\partial f_i/\partial x_1 = \partial f_i/\partial x_n \leq 0$. On the one hand, with the equation (3), one sees that $|x_n| \leq 1$; with the equation (3) again, one gets $|\partial f_i/\partial x_n| \leq 8$. On the other hand, since $|\phi'| \leq 1/3$, the equation (2) gives $|\partial f_i/\partial x_1| \geq |x_1|$. Finally, $|x_1| \leq 8$, and $x_1^2 + x_n^2 \leq 65$.

5.1.2. *Opposition close to the singularities.* Given a singularity s of ξ , let i be its Morse index. On a neighborhood, let f be a local first integral for ξ and let g be a local, flat Riemannian metric, such that ∇ is the gradient of f with respect to g (Definition 5.1). Let $\text{Hess}_s f$ denote the g -symmetric linear automorphism of $T_s M$ associated to the bilinear form $d_s^2 f$. Write $h := (\text{Hess}_s f)^{-1} V(s) \in T_s M$. Let $H \subset T_s M$ be the hyperplane g -orthogonal to $V(s)$, and $d^2 f_s$ -orthogonal to h . Let S be the g -symmetric endomorphism of H associated to $d_s^2 f|_H$.

We say that the opposition is *anisotropic* at s , with respect to ξ , if $d_s^2 f(h, h) \neq 0$. In other words, S is invertible.

LEMMA 5.5. *Consider the opposition between V and ∇ close to the singularity s .*

i) On some neighborhood of s , the opposition locus can be parametrized as a smooth curve $t \mapsto x(t)$ ($t \geq 0$) such that $x(0) = s$ and $x'(0) = -h$.

Assume moreover that the opposition is anisotropic at s . Assume that $d^2 f_s(h, h) > 0$ (resp. < 0). Then:

- ii) For every small $t > 0$, one has $(f \circ x)'(t) > 0$ (resp. < 0);
- iii) As t goes to 0, the tangent hyperplane $T_{x(t)}\xi$ goes to H ; and the rescaled framing

$$\mathcal{F}'_{x(t)}(V, \nabla) := \|V(x(t))\|^{-1} \|\nabla(x(t))\| \mathcal{F}_{x(t)}(V, \nabla)$$

goes to $-S$;

- iv) For every small $t > 0$, the opposition point $x(t)$ is hyperbolic w.r.t. ξ , the opposition index being $n - i - 1$ (resp. $n - i$);
- v) The family of planes and automorphisms $(T_{x(t)}\xi, \mathcal{F}'_{x(t)}(V, \nabla))$, extended at $t = 0$ by $(H, -S)$, is smooth at $t = 0$.

See Figure 10.

Proof. One identifies a neighborhood of s in M with an open subset of \mathbf{R}^n , and g with the Euclidean metric. One regards locally the vector fields as self-mappings of \mathbf{R}^n .

i) Put $F(x, t) := \nabla(x) + tV(x)$. The opposition curve is defined by $F(x, t) = 0$ and $t \geq 0$. The partial derivate $\partial F / \partial x|_{(s,0)} = -Hess_s f$ being invertible, by the Implicit Function Theorem, the opposition curve has a smooth parametrization $x(t)$ with $x(0) = s$; and $x'(0) = -h$.

ii) This is because $(f \circ x)'(0) = 0$ and $(f \circ x)''(0) = d_s^2 f(h, h)$.

iii) As t goes to 0, obviously, $T_{x(t)}\xi = V(x(t))^\perp$ goes to $V(s)^\perp = H$. Write ν for $-\|\nabla\|^{-1}\nabla$, the unit vector field positively normal to the level sets of f . At the regular opposition point $x := x(t)$, close enough to s , differentiate the projected vector field $X = V - \langle V, \nu \rangle \nu$ along the level set $L_x := f^{-1}(f(x))$. Recall that the Weingarten endomorphism $D_x(\nu|_{L_x})$ is also $\|\nabla(x)\|^{-1}S_x$, where S_x is the symmetric endomorphism of $T_x L_x$ associated to $d_x^2 f$. One finds after rescaling:

$$(4) \quad \mathcal{F}'_x(V, \nabla) = -S_x + \|V(x)\|^{-1} \|\nabla(x)\| (\text{pr} \circ D_x V)$$

where pr is the orthogonal projection of $T_x M$ onto $T_x L_x = V(x)^\perp$. As x goes to s , the first term does go to $-S$, while the second goes to 0.

iv) By the anisotropy hypothesis, $-S$ is hyperbolic and its stability index (the number of eigenvalues whose real part is negative) is $n - 1 - i$ (resp. $n - i$). By iii), so is the opposition framing at every opposition point close enough to s .

v) Follows at once from the formula (4) (of course, the function $\|\nabla(x(t))\|$ is smooth with respect to $t \geq 0$). \square

5.1.3. *Hyperbolic opposition and the homotopy class of output pseudogradients.* A hyperbolic opposition will allow us to control the homotopy class of the pseudogradients of the output foliation. The crucial step is of course when a pair of singularities is canceled (Lemma 2.8).

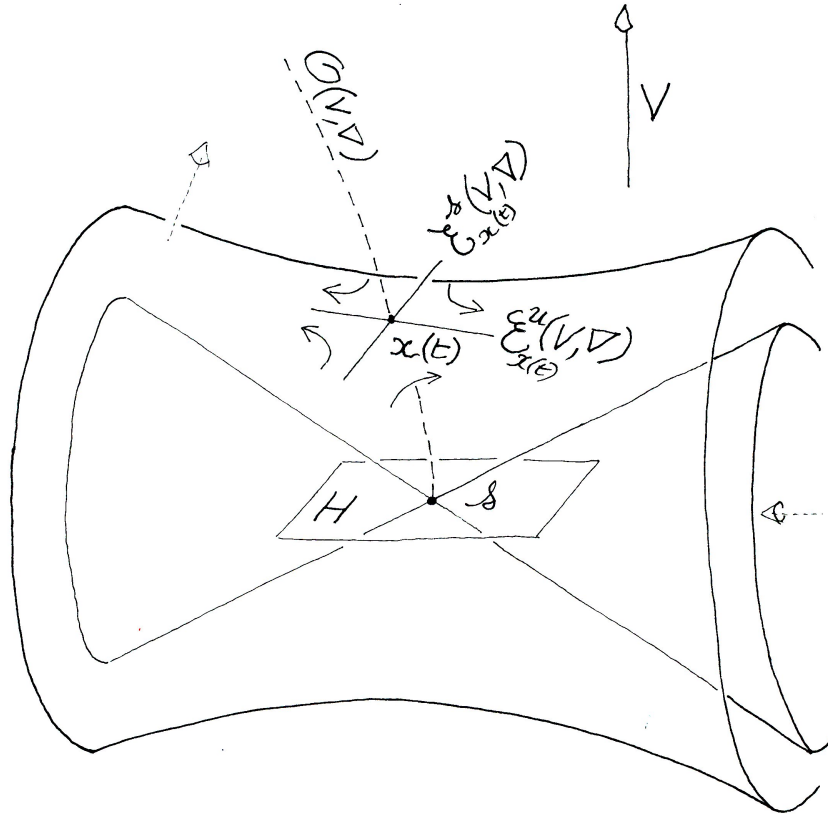

FIGURE 10. Opposition locus between a nonsingular vector field and a pseudogradient, close to a singularity. Some orbits of the vector field X , orthogonal projection of V on the leaves, have been sketched.

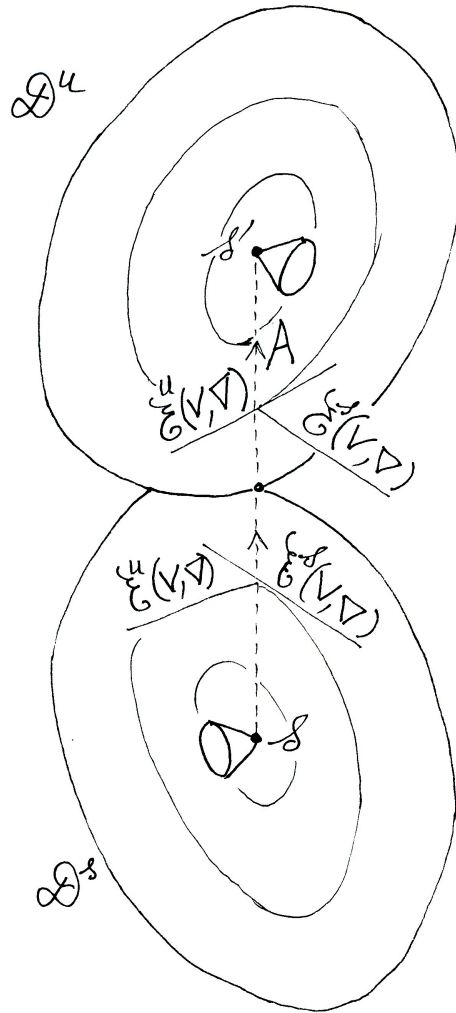

FIGURE 11. A cancellation pair of disks and an adapted opposition.

DEFINITION 5.6. (Figure 11) Consider a pair of singularities s, s' ; a cancellation pair of disks $\mathcal{D}^s, \mathcal{D}^u$ for ξ at s and s' ; an arc $A \subset \mathcal{D}^s \cup \mathcal{D}^u$

bounded by s and s' ; and a neighborhood N of $\mathcal{D}^s \cup \mathcal{D}^u$. We say that the opposition between V and ∇ is *adapted* to the quadruple $(N, \mathcal{D}^s, \mathcal{D}^u, A)$ if:

- i) The opposition locus in N coincides with A ;
- ii) Every regular opposition point $x \in A \setminus \partial A$ is hyperbolic; moreover, if $x \in \mathcal{D}^s$ (resp. \mathcal{D}^u), then the stable (resp. unstable) space $\mathcal{E}_x^s(V, \nabla)$ (resp. $\mathcal{E}_x^u(V, \nabla)$) is the intersection of $T_x \xi$ with $T_x \mathcal{D}^s$ (resp. $T_x \mathcal{D}^u$).

In Example 5.3, the opposition between $-\partial/\partial x_n$ and ∇f_i is adapted to the quadruple $(\mathbf{R}^n, \mathcal{D}^s, \mathcal{D}^u, [s, s'])$.

Note that, in Definition 5.6, the pseudogradient needs not be tangent to the cancellation disks, nor to the arc.

LEMMA 5.7. *Let f be a Morse function on an n -manifold M ; let s, s' be a pair of critical points of f admitting a pair of cancellation disks $\mathcal{D}^s, \mathcal{D}^u$; and let $A \subset \mathcal{D}^s \cup \mathcal{D}^u$ be an arc bounded by s and s' . Let $N \subset M$ be a sufficiently small, embedded compact n -ball containing $\mathcal{D}^s \cup \mathcal{D}^u$ in its interior. Let g be a noncritical function on some neighborhood of N , coinciding with f on ∂N . Let V be a nonsingular vector field on some neighborhood of N , s.t. $V \cdot f < 0$ on ∂N .*

Assume that f admits a pseudogradient whose opposition with V is adapted to the quadruple $(N, \mathcal{D}^s, \mathcal{D}^u, A)$.

Then, every pseudogradient for g which coincides with V on ∂N , is homotopic to V rel. ∂N .

OBSERVATION 5.8. From now on, we use repeatedly an (extremely obvious) convex homotopy trick to make V coincide with ∇ on any given closed subset $K \subset M$ disjoint from $\mathcal{O}(V, \nabla)$. One chooses some plateau function ϕ on M , equal to 1 on K , and whose support is disjoint from $\mathcal{O}(V, \nabla)$. The homotopy of nonsingular vector fields $V_t := (1 - t\phi)V + t\phi\nabla$ brings $V = V_0$ to V_1 , which equals ∇ on K . One changes V for V_1 ; the opposition locus with ∇ is not changed, nor the framing.

Proof of Lemma 5.7. Using the relative Morse Lemma (see 2.1), one embeds some small open neighborhood of $\mathcal{D}^s \cup \mathcal{D}^u$ into \mathbf{R}^n , such that f matches the function f_i of Example 2.2; that $s, s', \mathcal{D}^s, \mathcal{D}^u$ match the points s, s' and the disks $\mathcal{D}^s, \mathcal{D}^u$ of Example 2.2; and that A matches $[s, s']$. So, we are reduced to the situation where $M = \mathbf{R}^n$; where ξ is defined by f_i ; where $A = [s, s']$; and where $s, s', \mathcal{D}^s, \mathcal{D}^u$ are as in Example 2.2. We are given a compact n -ball N containing $\mathcal{D}^s \cup \mathcal{D}^u$ in its interior; a nonsingular vector field V on some neighborhood of N , s.t. $V \cdot f_i < 0$ on ∂N ; a pseudogradient ∇ for f_i on some neighborhood of N , whose opposition with V is adapted to the quadruple

$(N, \mathcal{D}^s, \mathcal{D}^u, [s, s'])$; a noncritical function g on some neighborhood of N , coinciding with f_i on ∂N ; and a pseudogradient ∇g for g , coinciding with V on ∂N .

We extend V and ∇ to \mathbf{R}^n , such that on $\mathbf{R}^n \setminus N$ one has $V \cdot f_i < 0$ and $\nabla \cdot f_i < 0$; and that on some neighborhood of ∞ one has $V = \nabla = -\partial/\partial x_n$. Then, one extends g and ∇g to \mathbf{R}^n , such that on $\mathbf{R}^n \setminus N$ one has $g = f_i$ and $\nabla g = V$.

One has to prove that ∇g is homotopic to V on N rel. ∂N ; or, equivalently, on \mathbf{R}^n rel. some neighborhood of ∞ . Since every orbit of ∇g descends from $\mathbf{R}^{n-1} \times (+\infty)$ down to $\mathbf{R}^{n-1} \times (-\infty)$, by Douady's chord trick [9], ∇g is homotopic to $-\partial/\partial x_n$ on \mathbf{R}^n rel. some neighborhood of ∞ . It remains to show that $-\partial/\partial x_n$ is homotopic to V on \mathbf{R}^n rel. some neighborhood of ∞ . This will follow from an elementary Pontryagin-Thom-like argument. However, reducing to the classical theory would be more tedious than giving the argument from scratch.

First, rescale V (multiplication by a positive function) to arrange that, on $[s, s']$, one has $\nabla/V = \partial f_i/\partial x_n$. Then, consider on \mathbf{R}^n the convex homotopies

$$V_t := (1-t)(-\partial/\partial x_n) + tV$$

$$\nabla_t := (1-t)\nabla f_i + t\nabla$$

The field V_t is nonsingular at every point x of $[s, s']$: indeed, at $x \neq s, s'$ (resp. $x = s$ or s'), both vectors $-\partial/\partial x_n$ and $V(x)$ lie on the same side of the hyperplane $\ker(d_x f_i)$ (resp. the hyperplane H of Lemma 5.5). The opposition locus between V_t and ∇_t contains $[s, s']$.

Claim: On some small neighborhood N' of $[s, s']$ in N , there appears during the homotopy no other opposition point between V_t and ∇_t .

Close to s and s' , the claim follows from Lemma 5.5, (i). Close to $x \in [s, s']$ s.t. $0 \leq x_n < 1$ (resp. $-1 < x_n \leq 0$), the reason is that the opposition framing between V_t and ∇_t at x is hyperbolic too. Indeed, thanks to the rescaling of V , one has

$$\mathcal{F}(V_t, \nabla_t) = (1-t)\mathcal{F}(-\partial/\partial x_n, \nabla f_i) + t\mathcal{F}(V, \nabla)$$

But, the opposition between $-\partial/\partial x_n$ and ∇f_i and the opposition between V and ∇ being both adapted to the quadruple $(N, \mathcal{D}^s, \mathcal{D}^u, [s, s'])$, one has

$$\mathcal{E}_x^s(-\partial/\partial x_n, \nabla f_i) = \mathcal{E}_x^s(V, \nabla)$$

$$\text{(resp. } \mathcal{E}_x^u(-\partial/\partial x_n, \nabla f_i) = \mathcal{E}_x^u(V, \nabla))$$

The set of the $(n-1) \times (n-1)$ real hyperbolic matrices whose stable (resp. unstable) space is $\mathbf{R}^{n-i-1} \times 0$ (resp. $0 \times \mathbf{R}^i$), is of course starred with respect to its point $-I_{n-i-1} \oplus I_i$. The claim is proved.

For every $x \in \mathbf{R}^n \setminus \{s, s'\}$, and for every $t \in [0, 1]$, the space of the vectors of \mathbf{R}^n not opposite to $\nabla_t(x)$ is contractible. On $\mathbf{R}^n \setminus [s, s']$, V_0 is not opposite to ∇_0 , and V_1 is not opposite to ∇_1 . On $N' \setminus [s, s']$, the field V_t is not opposite to ∇_t . On some neighborhood of ∞ , the field $V_t = -\partial/\partial x_n$ is not opposite to ∇_t . Hence, after the Homotopy Lifting Property for fibrations, the local homotopy $(V_t|_{N'})$ can be extended on \mathbf{R}^n by a homotopy (\bar{V}_t) of vector fields such that $\bar{V}_0 = -\partial/\partial x_n$; and $\bar{V}_1 = V$; and \bar{V}_t is not opposite to ∇_t at any point of $\mathbf{R}^n \setminus [s, s']$; and $\bar{V}_t = -\partial/\partial x_n$ on some neighborhood of ∞ . Lemma 5.7 is proved. \square

5.1.4. *Tools for modifying an opposition locus.* We end this paragraph by introducing three tools that will be used, in the next one, to modify the opposition locus.

- (1) Creation of a pair of cusps, by means of a local homotopy of V ;
- (2) Cancellation of a pair of cusps, by means of a homotopy of V ;
- (3) Creation of a pair of singularities and of an opposition arc with one cusp, by means of a local concordance of ξ , of a local modification of ∇ , and of a local homotopy of V .

(1) Let x be a regular, noncubic opposition point between V and ∇ . The local creation of a pair of cusps close to x can be seen as a standard application of the elementary Pontryagin-Thom theory (see e.g. [14]). Consider a neighborhood $N \cong \mathbf{D}^{n-1} \times \mathbf{D}^1$ of x , in which ξ is the height foliation, and whose intersection with $\mathcal{O}(V, \nabla)$ is $A := 0 \times \mathbf{D}^1$. One fixes a parallelization of the manifold N with respect to which the vector field ∇ is parallel. The nonsingular vector fields in N are seen as maps to \mathbf{S}^{n-1} . Let A' be in N an arc isotopic to A rel. ∂A , and on which the height function is Morse, with two singularities. In $N \times [0, 1]$, the arcs A and A' , together with $\partial A \times [0, 1]$, bound a topological disk. By Theorems B and C of [14] there is on N a nonsingular vector field V' , homotopic to V rel. ∂N , such that $\mathcal{O}(V', \nabla) = A'$; and the opposition is nondegenerate. We change V to V' in N .

(2) Let $c_0, c_1 \in \mathcal{O}(V, \nabla)$ be two cusps of respective indices 0 and 1. Since ξ is minimal, c_0 and c_1 bound in M an oriented arc T transverse to ξ , and disjoint from $\mathcal{O}(V, \nabla)$ but at c_0 and c_1 . Consider a small neighborhood $N \cong \mathbf{D}^{n-1} \times \mathbf{D}^1$ of T , in which ξ is the height foliation, and whose intersection with $\mathcal{O}(V, \nabla)$ consist of two small arcs A_0, A_1 centered at c_0, c_1 , with $\partial A_0 \subset \mathbf{D}^{n-1} \times (+1)$ and $\partial A_1 \subset \mathbf{D}^{n-1} \times (-1)$. One completes the square with two disjoint arcs $A', A'' \subset N$ transverse to the height foliation, and such that $\partial(A' \cup A'') = \partial(A_0 \cup A_1)$. One chooses A' and A'' such that $\mathcal{F}(V, \nabla)$ has the same Euler-Poincaré index at the two endpoints of A' (resp. A''). As before, by Theorems

B and C of [14], there is on N a nonsingular vector field V' , homotopic to V rel. ∂N , such that $\mathcal{O}(V', \nabla) = A' \cup A''$; and the opposition is nondegenerate. We change V to V' in N . As a result, the locus $\mathcal{O}(V, \nabla)$ has been modified through an elementary surgery.

(3) Given two indices i, j , such that $1 \leq i \leq n - 2$ and $j = 0$ or 1 , choose in M a point x where V and ∇ are not opposite.

Then, x admits a small open neighborhood $U \cong \mathbf{R}^n$ whose closure \bar{U} is disjoint from $\mathcal{O}(V, \nabla)$; and in which ξ is defined by the polynomial function $F_i^n = Q_i^n + x_n^3 + 3x_n$ of Example 2.2; and in which ∇ is positively colinear to $-\partial/\partial x_n$. Since, at every regular point, the set of vectors tangent to M and not opposite to ∇ is contractible, after a homotopy of V among the vector fields not opposite to ∇ , supported in a small neighborhood of \bar{U} , one can arrange that $V = (-1)^{j+1}\partial/\partial x_1 - \partial/\partial x_n$ in U . In U , we change ξ for the Γ_1 -structure defined by f_i (see Example 2.2), thus creating a pair of singularities of indices $i, i + 1$. Also, let ∇' be a pseudogradient for f_i on U , equal to the negative Euclidean gradient ∇f_i on some neighborhood K of $\mathcal{O}(V, \nabla f_i)$, and to ∇ on some neighborhood $U \setminus K'$ of ∂U . By the homotopy lifting property for fibrations, there is a nonsingular vector field V' on U , homotopic to V rel $K \cup (U \setminus K')$, and nowhere opposite to ∇' on $U \setminus K$. In U , we change ∇ for ∇' and V for V' . Then, in U , the opposition is normal; the opposition locus between V and ∇ is an arc between the two singularities; and there is a unique cusp on this arc, of index j (Example 5.4, d).

5.2. End of the proof of Theorem A. We come back to the data of a closed n -manifold M ($n \geq 4$), endowed with a minimal, co-oriented Morse Γ_1 -structure ξ ; and with a nonsingular vector field V .

Let ∇ be a pseudogradient for ξ on M .

5.2.1. Anisotropy, nondegeneracy, and Morse position. First, we arrange that:

- a) At every singularity of ξ , the opposition curve between V and ∇ is not tangent to the isotropic cone of ξ ;
- b) Every regular opposition point is nondegenerate;
- c) Every cubic opposition point is a cusp.

For ξ and ∇ fixed, these are *generic* properties of the nonsingular vector field V . Indeed, close to the singularities, the genericity of (a) and (b) follows at once from Lemma 5.5, (i) and (iv). On the rest of M , the genericity of (b) follows from the Thom Transversality Theorem; the genericity of (c) follows from the classical normal form Theorem for the one-parameter families of germs of vector fields; but we don't even need this classical result. Alternatively, once (a) and (b) have

been fulfilled, the opposition locus is a smooth submanifold of M of dimension 1, whose boundary is exactly the set of singularities of ξ . To get (c), we can more simply push V and ∇ by a common, C^1 -small isotopy of M , relative to some small neighborhood of the singularities. By the Thom Transversality Theorem, a generic such isotopy pushes the opposition curve to the Morse position with respect to ξ .

5.2.2. Acyclicity and noncubicity. The locus $\mathcal{O}(V, \nabla)$ may have some connected components homeomorphic to the circle. On each of them, using tool (1) of paragraph 5.1.4, we create a pair of cusps. Now, no circle connected component is cusp-free.

For every cusp c of index 0 (resp. 1) on $\mathcal{O}(V, \nabla)$, using tool (3), we create an opposition arc bearing a cusp c' of index 1 (resp. 0). Using tool (2), we cancel c with c' . Now, every regular opposition point is noncubic; and every connected component of $\mathcal{O}(V, \nabla)$ is an arc transverse to ξ .

For each opposition arc A , orient A by the co-orientation of ξ ; let $\partial_0 A$ (resp. $\partial_1 A$) be the lower (resp. upper) endpoint; let $i_0(A)$ (resp. $i_1(A)$) be the Morse index of ξ at this endpoint; and let $\delta(A) := i_1(A) - i_0(A)$. This integer is odd, since the Poincaré-Hopf degree of the opposition, which is constant along A , equals $(-1)^{i_0(A)}$ close to $\partial_0 A$, and $(-1)^{i_1(A)-1}$ close to $\partial_1 A$ (Lemma 5.5, iv).

Note that, if the opposition happens to be hyperbolic along A , then $\delta(A) = 1$. This follows at once from Lemma 5.5 (iv), the stability index being constant along A .

5.2.3. Making δ equal 1. Our next task is to arrange that $\delta(A) = 1$ for every opposition arc A (Figure 12). In case $\delta(A) \geq 3$ (resp. $\delta(A) \leq -1$), one creates on A a pair of cubic points c_0, c_1 of respective indices 0 and 1 (tool 1). Note that the points $\partial_0 A, c_1, c_0, \partial_1 A$ lie in this order along A . Also, by two uses of the tool (3), one creates in M two new opposition arcs A', A'' , such that $i_0(A') = i_0(A) + 1$ (resp. $i_0(A') = i_0(A) - 2$) and $i_1(A') = i_0(A) + 2$ (resp. $i_1(A') = i_0(A) - 1$) and $i_0(A'') = i_0(A) + 1$ (resp. $i_0(A'') = i_0(A)$) and $i_1(A'') = i_0(A) + 2$ (resp. $i_1(A'') = i_0(A) + 1$). The new opposition arcs have two cusps $c' \in A', c'' \in A''$ of respective indices 1 and 0. One cancels c_0 with c' and c_1 with c'' (tool 2). One is left, instead of A , with three opposition arcs B, C, D without cubic points. One has $\partial_0 B = \partial_0 A$ and $\partial_1 B = \partial_0 A''$ (resp. $\partial_0 B = \partial_0 A$ and $\partial_1 B = \partial_1 A''$), so $\delta(B) = 1$; one has $\partial_0 C = \partial_0 A'$ and $\partial_1 C = \partial_1 A''$ (resp. $\partial_0 C = \partial_1 A'$ and $\partial_1 C = \partial_0 A''$), so $\delta(C) = 1$; one has $\partial_0 D = \partial_1 A'$ and $\partial_1 D = \partial_1 A$ (resp. $\partial_0 D = \partial_0 A'$ and $\partial_1 D = \partial_1 A$), so $\delta(D) = \delta(A) - 2$ (resp. $\delta(D) = \delta(A) + 2$).

Iterating this process, one gets $\delta = 1$ for all the opposition arcs.

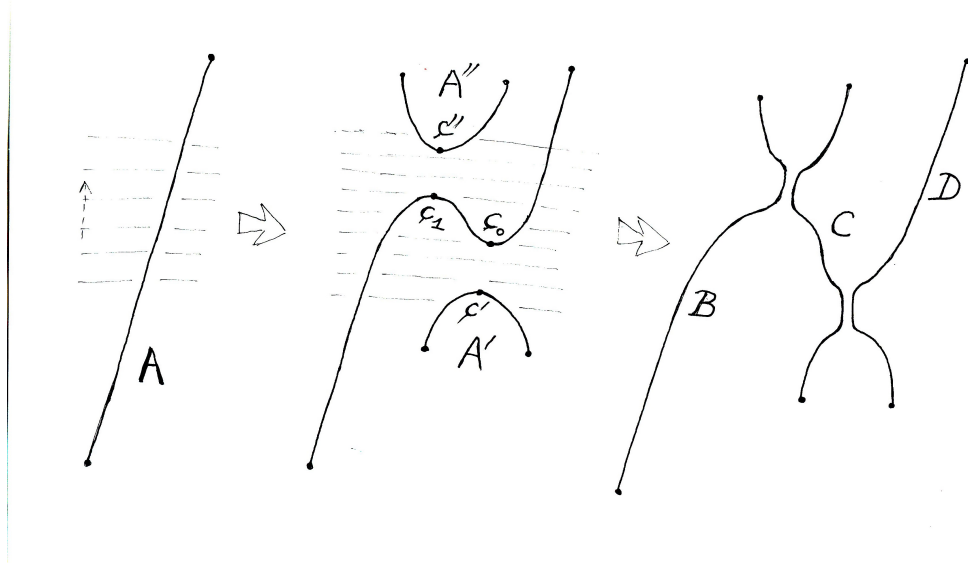
FIGURE 12. Reducing δ , in the case $\delta \geq 3$.

5.2.4. *Hyperbolicity.* Here, we moreover make every regular opposition point hyperbolic; by means of a homotopy of V in a small neighborhood of the opposition locus, and relatively to some small neighborhood of the singularities. The opposition locus itself will not be changed.

Consider an opposition arc A . Close to both its endpoints, $\mathcal{F}(V, \nabla)$ is hyperbolic, with the same stability index $\sigma := n - i_0(A) - 1$ (by Lemma 5.5, iv, and $\delta(A) = 1$). Applying Theorems B and C of [14] in a small neighborhood of some large subarc $A' \subset A \setminus \partial A$, one is reduced to homotope the opposition framing $\mathcal{F}(V, \nabla)|_{A'}$ to some hyperbolic framing, relatively to $\partial A'$.

Since no singularity of ξ is a local extremum, one has $1 \leq \sigma \leq n - 2$. In the linear group $GL(\mathbf{R}^{n-1})$, consider the subset H_σ of the hyperbolic automorphisms whose stable invariant subspace is of dimension σ . Of course, H_σ is connected (being homotopy equivalent to the Grassmannian manifold of the σ -planes in \mathbf{R}^{n-1}). Consider also the connected component $GL_\pm(\mathbf{R}^{n-1})$ of $GL(\mathbf{R}^{n-1})$ containing H_σ . We are reduced to the remark that $GL_\pm(\mathbf{R}^{n-1})$ is simply connected relatively to H_σ . This fact is well evident: at the basepoint $h := (-I)_\sigma \oplus I_{n-1-\sigma}$, the fundamental group of $GL_\pm(\mathbf{R}^{n-1})$ is generated by the loop $(u_\theta h)$,

where (u_θ) ($\theta \in [0, 2\pi]$) is any one-parameter subgroup of rotations in \mathbf{R}^{n-1} . We choose u_θ to be the rotation of angle θ in the $(x_1, x_{\sigma+1})$ -plane, and the identity in the other coordinates. Then, of course, $u_\theta h = (u_{\theta/2})h(u_{\theta/2})^{-1}$ is hyperbolic for every θ .

5.2.5. Adapted disks, and cancellation. Then, for every opposition arc A , we modify ξ in a small neighborhood of A , so that its endpoints s , s' get in cancellation position, just as in paragraph 3.2; but we arrange that the cancellation pair of disks that we create is adapted (Definition 5.6) to the opposition between V and ∇ . Here are the details.

Let i and $i + 1$ be the respective indices of s and s' . Recall the family of the stable, framing-invariant $(n - i - 1)$ -planes $\mathcal{E}^s(V, \nabla) \subset T\xi$, defined and smooth over $A \setminus \partial A$. By Lemma 5.5 (v) and the anisotropy of A at s , this family extends smoothly at the endpoints of A ; the limit plane $H^u \subset H$ is the unstable, S -invariant subspace. Therefore, one has in M an open $(n - i)$ -disk D containing A , and whose tangent space at every $x \in A \setminus \partial A$ (resp. at s) is $\mathcal{E}_x^s(V, \nabla)$ (resp. H^u). In particular, s is a nondegenerate local minimum of $f|_D$. By the Morse Lemma, D contains a small stable disk \mathcal{D}^s for ξ at its singularity s . Symmetrically, one has an open $(i + 1)$ -disk D' containing A , and whose tangent space at every $x \in A \setminus \partial A$ is $\mathcal{E}_x^u(V, \nabla)$; and ξ has at s' a small unstable disk $\mathcal{D}^u \subset D'$.

Write $a \subset A$ for the compact subarc whose endpoints are $A \cap \partial \mathcal{D}^s$ and $A \cap \partial \mathcal{D}^u$. One can arrange, changing ∇ and V without changing the homotopy class of V , nor the opposition locus, nor the opposition framing, that ∇ is tangential to D and to D' on a neighborhood U of a . Indeed, by means of a partition of the unity, one makes a pseudogradient ∇' for ξ , equal to ∇ outside some small neighborhood of a , and tangential to D and to D' on a smaller neighborhood U of a ; one splits V on $M \setminus \text{Sing}(\xi_{\min})$ as $V = X + u\nabla$ where X is tangential to ξ and where u is a function; one changes ∇ to ∇' ; one changes V to $X + u\nabla'$, which is of course homotopic to V .

Then, shrinking U if necessary, we identify U with \mathbf{R}^n as in paragraph 3.2. Since ∇ is tangential to D and to D' , we can arrange moreover that the identification turns ∇ into $-\partial/\partial x_n$ (up to some positive function factor); turns $D \cap U$ into $\mathbf{R}^{n-i-1} \times 0 \times \mathbf{R}$; and turns $D' \cap U$ into $0 \times \mathbf{R}^i \times \mathbf{R}$. Consequently, after rescaling ∇ :

- (1) On $\mathbf{R}^n \setminus H_i^n$, the field ∇ is a pseudogradient for the Γ_1 -structure ξ_{whl} ;
- (2) In the hole H_i^n , the field ∇ coincides with the height gradient;
- (3) The opposition between V and ∇ is adapted to the cancellation pair of disks $\Phi(\mathcal{D}^s), \mathcal{D}^u$.

Let N_A be in M a small open neighborhood of $\Phi(\mathcal{D}^s) \cup \mathcal{D}^u$, diffeomorphic to the open n -ball, so small that ξ admits a first integral f on N_A , and so small that Lemma 2.3 applies. Just as in paragraph 3.2, in N_A one changes ξ to the Γ_1 -structure defined by the noncritical function g . Having done so for each component A of $\mathcal{O}(V, \nabla)$, one gets a minimal foliation \mathcal{F}_{hol} on $M_{\text{hol}} := M$ minus the holes.

Let $N \subset M$ be the union of the N_A 's. After a homotopy of V whose support is disjoint from the opposition locus, we can arrange moreover that $V = \nabla$ on some neighborhood of $M \setminus N$ (since at every regular point, the set of vectors tangent to M and not opposite to ∇ is contractible). Let ∇' be a vector field on M which is a pseudogradient for \mathcal{F}_{hol} in each N_A , and coincides with ∇ on some neighborhood of $M \setminus N$. For each component A , the hypotheses of Lemma 5.7 are fulfilled in N_A . By this Lemma, V is homotopic to ∇' relatively to $M \setminus N$. We change V to ∇' on M .

5.2.6. *Worm galleries.* We are left with a foliation \mathcal{F}_{hol} on M_{hol} ; and with a nonsingular vector field V on M , which is a pseudogradient for \mathcal{F}_{hol} on M_{hol} , and which coincides with the height gradient in each hole.

As in paragraph 3.3, we attach, to every connected component of every hole, a worm path in M_{hol} , transverse to \mathcal{F}_{hol} , from the ceiling of the hole to its floor. After a homotopy of V supported in a small neighborhood of the worm paths, one can arrange that V is moreover tangential to the worm paths. Then, when we enlarge the worm paths to make worm galleries, as in paragraph 3.3, we can choose the enlargement so that in every gallery, the height gradient is positively colinear to V .

5.2.7. *Filling the holes.* Finally, one fills the holes, as in paragraph 3.3: that is, let M_{HOL} be the complement in M of the interiors of the enlarged holes, and let $\mathcal{F}_{\text{HOL}} := \mathcal{F}_{\text{hol}}|_{M_{\text{HOL}}}$. One extends \mathcal{F}_{HOL} by a foliation inside each enlarged hole, obtaining a foliation \mathcal{F} on M , concordant with ξ .

It remains to arrange that \mathcal{F} admits a pseudogradient $\nabla \mathcal{F}$ which coincides with V on M_{HOL} , and which is homotopic to V relatively to M_{HOL} .

In the parts of the enlarged holes that one fills by suspensions, one defines of course $\nabla \mathcal{F}$ as the height gradient. So, one is reduced to arrange that, in Lemmas 3.3 and 3.4, the filling foliation \mathcal{F} admit a pseudogradient $\nabla \mathcal{F}$ equal to the height gradient $-\partial/\partial y$ along ∂H , and homotopic to $-\partial/\partial y$ rel. ∂H .

Consider first the straight case. In paragraphs 3.3.1, 3.3.2 and 3.3.3, we can choose ϕ_1 such that moreover, $\phi_1(y) \geq y$ for every $y \in \mathbf{D}^1$. So, in the hypotheses of Lemma 3.3, one has moreover $\psi_1(y) \geq y$. Then, in H , obviously \mathcal{F} admits a pseudogradient $\nabla \mathcal{F}$, equal to $-\partial/\partial y$ along ∂H , such that $(\nabla \mathcal{F}) \cdot \theta_1 \geq 0$ at every point of H . Here, θ_1 is, of course, the projection of \mathbf{T}^r onto its first \mathbf{S}^1 factor. Then, $\nabla \mathcal{F}$ and $-\partial/\partial y$, being both nowhere opposite to $\partial/\partial \theta_1$, are homotopic rel. ∂H .

The round case is similar, the condition $\psi_1(y) \geq y$ referring to the connected component of $\mathbf{S}^1 \setminus K$ containing y , oriented by the orientation of \mathbf{S}^1 .

6. GENERALIZATIONS

Our Theorem A (as well as Thurston's existence theorem) is indeed more general than the form given in the introduction, in three ways:

- The compact manifold M may have a smooth boundary. We shall consider only the construction of foliations *transverse* to this boundary;
- One works in any differentiability class C^r , $1 \leq r \leq \infty$;
- The Γ_1 -structures are not necessarily co-oriented.

In full generality, on the manifold M , a codimension-one *Haefliger structure* of class C^r — more briefly a Γ_1^r -*structure* [4][5] — can be defined as a pair $\xi = (\nu(\xi), \mathcal{F}(\xi))$:

- A rank-one real vector bundle $\nu(\xi)$ over M : the *normal* bundle;
- In the total space of $\nu(\xi)$, a germ, along the zero section $Z(M)$, of codimension-one foliation $\mathcal{F}(\xi)$ of class C^r , transverse to every fibre: the *microfoliation*.

The Γ_1^r -structure is *regular* at a point $x \in M$ if Z is transverse to $\mathcal{F}(\xi)$ at x . One makes no distinction between a foliation and a regular Γ_1 -structure. A concordance between two Γ_1^r -structures ξ_0, ξ_1 on M means a Γ_1^r -structure on $M \times [0, 1]$ whose restriction to $M \times i$ coincides with ξ_i ($i = 0, 1$). Then, $\nu(\xi_0)$ and $\nu(\xi_1)$ are isomorphic. A $(\nu(\xi))$ -*twisted* tangent vector V at a point $x \in M$ is a linear morphism $\nu(\xi)_x \rightarrow \tau M_x$. If V is transverse to ξ , the sign of this transversality is well-defined. If ξ is regular, it admits a *gradient*, that is, a $\nu(\xi)$ -twisted vector field negatively transverse to ξ .

THEOREM A'. *Let*

- M be a compact manifold of dimension at least 4;
- ξ be a Γ_1^r -structure ($1 \leq r \leq \infty$) on M , inducing a foliation on ∂M ;

- V be a nonsingular, $\nu(\xi)$ -twisted vector field on M , tangential to ∂M , and whose restriction to ∂M is a gradient for $\xi|_{\partial M}$.

Then, there is a minimal C^r foliation on M , concordant to ξ rel. ∂M (as a Γ_1^r -structure), and whose gradient is homotopic to V rel. ∂M (as a nonsingular, $\nu(\xi)$ -twisted vector field).

The generalization of the h -principle to manifolds with boundary is, of course, the key to classifying foliations up to concordance. Here is a simple example of a nontrivial application of our Theorem A' for manifolds with boundary. *Any two linear foliations of codimension one on the 3-torus are concordant through some smooth foliation of $\mathbf{T}^3 \times [0, 1]$ without interior leaf.*

We now indicate the few changes to be made in the sections 4 and 5.2, in order to prove Theorem A'.

To pass to the relative version, just change M for $\text{Int}(M)$ wherever necessary: one never has to modify ξ , nor V , on the boundary.

Of course, in class C^1 , the notion of Morse singularity is not defined. Without co-orientability, the index of a Morse singularity is not defined; and the index of a cusp opposition point (see vocabulary 5.2) is not defined. However, an arbitrary differentiability class C^r ($1 \leq r \leq \infty$) and/or a lack of differentiability will make few problems, because one will always arrange to work in an open subset $\Omega \subset M$ on which ξ is co-orientable and smooth (C^∞). To this end, five places in the proof need some care.

i) In section 4, by assumption, the foliation \mathcal{X} representing the germ $\text{pr}_1^*(\mathcal{F}(\xi))$ in U is of class C^r . First, it is not difficult to make a section σ_1 of $\nu(\xi)$ of class C^1 over $M \times 1$, which is U -valued, and whose tangency points with \mathcal{X} are isolated ([11], Proposition 2.1). Second, \mathcal{X} is easily smoothed in a neighborhood of these tangency points, through some ambient, C^1 -small isotopy of class C^r in U . Third, one takes for σ a generic, smooth, U -valued section of $\text{pr}_1^*(\nu(\xi))$ over \bar{M} , null over $M \times 0$, and C^1 -close to σ_1 over $M \times 1$. So, $\eta := \sigma^*(\mathcal{X})$ is of class C^r , and smooth in a neighborhood of its boundary singularities, which are Morse. From this moment, one always works with a Γ_1^r -structure which is C^r on M , smooth on a neighborhood of its singularities; and the singularities are Morse.

ii) In section 5.2, V is understood smooth; all pseudogradients are understood smooth. In paragraph 5.2.1, after (a) and (b) have been fulfilled, $\mathcal{O}(V, \nabla)$ is a smooth submanifold of M of dimension 1, transverse to ξ in a neighborhood of its boundary $\text{Sing}(\xi)$. The property (c) still makes sense provided that ξ is smooth in an open neighborhood of $\mathcal{O}(V, \nabla)$. To get this local smoothness and (c), one will push ξ

successively by four isotopies of M , of class C^r , small in topology C^1 , and relative to some neighborhood of $Sing(\xi)$. A first isotopy allows us to arrange that ξ has only a finite number of tangency points with the curve $\mathcal{O}(V, \nabla)$ (cubic opposition points). Then, using the elementary Weierstrass Approximation Theorem, one has a second isotopy, with support in some small neighborhood of these tangency points, which makes ξ smooth in some smaller, open neighborhood N of the tangency points. After this second isotopy, the tangency points form a compact subset of N . Then, using the Thom Transversality Theorem, one has a third isotopy, smooth and with support in N , which makes all tangency points be cusps. There remains to make ξ smooth close to the arcs of $\mathcal{O}(V, \nabla)$ bounded by the cusps and the endpoints, and close to the cusp-free circle components of $\mathcal{O}(V, \nabla)$. Since these arcs and circles are transverse to ξ , this is easily realized by a fourth isotopy, whose support is contained in a small neighborhood of $\mathcal{O}(V, \nabla)$, but disjoint from the singularities and the cusps.

iii) At the beginning of the paragraph 5.2.2, one replaces a cusp c by a new opposition arc. This construction can take place in a small neighborhood of c , where ξ is co-oriented and smooth.

As soon as $\mathcal{O}(V, \nabla)$ is a union of arcs transverse to ξ except at their endpoints, obviously ξ is co-orientable (and smooth) in some open neighborhood Ω of $\mathcal{O}(V, \nabla)$. One fixes arbitrarily a co-orientation Or in Ω .

iv) In the paragraph 5.2.3, one uses tool (2) several times to cancel some pairs of cusps. Let c, c' be one of these pairs, of respective indices 0 and 1 with respect to Or . This tool needs an arc T in M transverse to ξ , such that $\partial T = \{c, c'\}$, and such that the co-orientation Or extends along T . But such an arc does exist, because every codimension-one, minimal foliation which is *not* co-orientable, has a strong transitivity property: for every two points x, y and every two tangent vectors $v \in T_x M$, $w \in T_y M$ both transverse to the foliation, there is a transverse path $\gamma : [0, 1] \rightarrow M$ such that $\gamma(0) = x$, $\gamma'(0) = v$, $\gamma(1) = y$, and $\gamma'(1) = w$. Also, one makes ξ smooth on some neighborhood of T , by a C^1 -small isotopy of class C^r . We extend Ω by a small open neighborhood of T .

So, we keep an open neighborhood Ω of $\mathcal{O}(V, \nabla)$ where ξ is smooth and co-oriented.

v) The rest of the proof (paragraphs 5.2.3 through 5.2.7) takes place in Ω , except for the worm galleries (paragraph 5.2.6).

For each connected component of each hole, recall that a worm path means a path in M minus the holes, transverse to ξ , and joining the ceiling of the component to its floor. Such a path does exist, thanks to

the strong transitivity property recalled in iv). Then, the worm path being transverse to ξ , one can make ξ smooth in a small neighborhood of the arc, through some C^1 -small isotopy of class C^r , whose support is close to the arc; and then dig the gallery in this neighborhood. Also, the co-orientation of $\nu\xi$ over the component obviously extends first over the worm path, and then, over the gallery.

REFERENCES

- [1] C. Bonatti, *Existence de feuilletages singuliers de codimension 1 à feuilles denses sur les variétés compactes sans bord*, C. R. Acad. Sci. Sér. I Math. 300 (1985), 493–496, MR0788979, Zbl 0576.57024.
- [2] D. B. A. Epstein, *The simplicity of certain groups of homeomorphisms*, Compos. Math. 22 (1970), 165–173, MR0267589, Zbl 0205.28201.
- [3] D. B. A. Epstein, *Commutators of C^∞ -diffeomorphisms*, appendix to *A curious remark concerning the geometric transfer map*, by John N. Mather. Comment. Math. Helv. 59 (1984), 111–122, MR0743945, Zbl 0535.58007.
- [4] A. Haefliger, *Structures feuilletées et cohomologie à valeurs dans un faisceau de groupoïdes*, Comment. Math. Helv. 32 (1958), 248–329, MR0100269, Zbl 0085.17303.
- [5] A. Haefliger, *Espaces universels pour les feuilletages*, Colloque de Topologie Différentielle (Mont Aigoual 1969), Université de Montpellier, 11–17, MR0256412, Zbl 0207.54104.
- [6] M.R. Herman, *Simplicité du groupe des difféomorphismes de classe C^∞ , isotopes à l'identité, du tore de dimension n* , C. R. Acad. Sci. Paris, Sér. A-B, 273 (1971), A232–A234, MR0287585, Zbl 0217.49602.
- [7] M.R. Herman, *Sur le groupe des difféomorphismes du tore*, Ann. Inst. Fourier (Grenoble) 3 (1973), 75–86, MR0391166, Zbl 0269.58004.
- [8] M.R. Herman, *Sur la conjugaison différentiable des difféomorphismes du cercle à des rotations*, Inst. Hautes Etudes Sci. Pub. Math. 49 (1979), 5–233, MR0538680, Zbl 0448.58019.
- [9] F. Laudenbach, *Formes différentielles de degré 1 fermées non singulières: classes d'homotopie de leurs noyaux*, Comment. Math. Helv. 51 (1976), 447–464, MR0428335, Zbl 0354.58001.
- [10] F. Laudenbach, *A proof of Morse's Theorem about the cancellation of critical points*, C. R. Acad. Sci. Paris, Ser. I 351 (2013), 483–488, MR3090134, Zbl 1279.57023.
- [11] F. Laudenbach, G. Meigniez, *Haefliger's codimension-one singular foliations, open books and twisted open books in dimension 3*, Bull. Braz. Math. Soc. (N.S.) 43, 3 (2012), 347–373, MR3024060, Zbl 1263.57022.
- [12] H. Blaine Lawson Jr. *Foliations*, Bull. Amer. Math. Soc. 80 (1974), 369–418, MR0343289, Zbl 0293.57014.
- [13] J. N. Mather, *Integrability in codimension 1*, Comment. Math. Helv. 48 (1973), 195–233, MR0356085, Zbl 0284.57016.
- [14] J. W. Milnor, *Topology from the Differentiable Viewpoint*, Princeton University Press, Princeton, N.J. (1965), parag. 7, 42–51, MR0226651; revised reprint (1997), MR1487640, Zbl 0136.20402.

- [15] J. W. Milnor, *Lectures on the h-cobordism Theorem*, notes by L. Siebenmann and J. Sondow, Princeton University Press, Princeton, N.J. (1965), MR0190942, Zbl 0161.20302.
- [16] M. Morse, *Bowls of a non-degenerate function on a compact differentiable manifold*, in *Differential and Combinatorial Topology*, ed. S. S. Cairns, Princeton University Press, Princeton, N.J. (1965), 81–103, MR0182026, Zbl 0159.24803.
- [17] P. Schweitzer, S.J. *Codimension one foliations without compact leaves*, *Comment. Math. Helv.*, vol. 70 (1995), 171–209, MR1324626, Zbl 0843.57028.
- [18] W. Thurston, *The theory of foliations of codimension greater than one*, *Comment. Math. Helv.* 49 (1974), 214–231, MR0370619, Zbl 0295.57013.
- [19] W. Thurston, *Existence of codimension-one foliations*, *Annals of Math.* 104 (1976), 249–268, MR0425985, Zbl 0347.57014.
- [20] W. Thurston, *On Proof and Progress in Mathematics*. *Bull. Amer. Math. Soc.* 30 (2) (1994), 161–177, MR1249357, Zbl 0817.01031.

UNIVERSITÉ DE BRETAGNE SUD, LMBA_UBS, CNRS UMR 6205, BP 573,
F-56017 VANNES, FRANCE
E-mail address: Gael.Meigniez@univ-ubs.fr