



HAL
open science

Emission spectroelectrochemistry: cell design and set-up

Olivier Alévêque, Eric Levillain

► **To cite this version:**

Olivier Alévêque, Eric Levillain. Emission spectroelectrochemistry: cell design and set-up. Luminescence in Electrochemistry: Applications in Analytical chemistry, Physics, and Biology, 1, Springer International Publishing, pp.1-19, 2017, 978-3-319-49135-6. 10.1007/978-3-319-49137-0_1 . hal-01449607

HAL Id: hal-01449607

<https://hal.science/hal-01449607v1>

Submitted on 16 Jul 2020

HAL is a multi-disciplinary open access archive for the deposit and dissemination of scientific research documents, whether they are published or not. The documents may come from teaching and research institutions in France or abroad, or from public or private research centers.

L'archive ouverte pluridisciplinaire **HAL**, est destinée au dépôt et à la diffusion de documents scientifiques de niveau recherche, publiés ou non, émanant des établissements d'enseignement et de recherche français ou étrangers, des laboratoires publics ou privés.

Chapter 2

Emission spectroelectrochemistry: cell design and set-up

Olivier ALEVEQUE and Eric LEVILLAIN*

Laboratoire MOLTECH Anjou - Université d'Angers/CNRS UMR6200

2, Boulevard Lavoisier - 49045 ANGERS Cedex - France

Email: eric.levillain@univ-angers.fr

Abstract: This chapter reviews the most recent developments in the fluorescence spectroelectrochemistry, coupled detection of fluorescence and electrochemical signals. It focuses on the instrumental development in fluorescence spectroelectrochemistry and recent coupling of electrochemical techniques with fluorescence microscopy. The first part is dedicated to conventional fluorescence spectroelectrochemistry cells and the second one to the electrochemistry and fluorescence microscopy coupling.

2.1 Introduction and chapter scope

Spectroelectrochemistry (SEC) combines both electrochemical and spectroscopic experiments and affords the investigation and identification of electroactive species under different redox states or products arising from redox reactions [1-13]. The strength of this technique relies on generating spectroscopic information about *in situ* electrogenerated species. The coupling can be done, for example, with electronic absorption (UV/VIS/NIR Absorption), light emission and scattering (Fluorescence), vibrational modes and frequencies (IR and Raman), magnetic resonance (NMR) and electron spin resonance (ESR).

Combined results from electrical and optical responses allow detailed insights in underlying mechanisms and more precise studies than each process taken separately.

The typical application fields that involve spectroelectrochemistry are bioelectrochemistry, redox polymer processes, molecular electrochemistry, molecular switches, and organometallic reactions among others.

Historically, time resolved spectroelectrochemistry was introduced in the 90's to study molecules in solution. Over the years, it became a complementary analytical technique to conventional electrochemical methods. The electrochemical measurement (*i.e.* cyclic voltammetry and/or chronoamperometry) was first coupled to multichannel UV-visible-NIR spectrophotometry [14-18], then adapted to micro-Raman [19,20], rapid scan infrared [21-23], fluorescence [24,25], ESR [26,27], EXAFS [28], etc. Over the past 15 years or so, the improvement in electronic devices and the lowering cost of CCD detectors has extended the spectroelectrochemical analytical range to modified electrodes (*i.e.* mono, multi-layers or conducting polymers).

Since there are a lot potential analytical applications, especially in biochemistry [29-31,4,32], where in situ dual detection of electrochemical and fluorescence signals can lead to very sensitive and selective biosensors, this chapter reviews the most recent cell design and set-up developments in the fields of fluorescence spectroelectrochemistry (F-SEC), coupled detection of fluorescence and electrochemical signals of molecules and materials exhibiting electrofluorochromic properties.

The first part (Part 2.2) focuses on the conventional F-SEC whereas the second one is dedicated to the coupling of electrochemistry and fluorescence microscopy (Part 2.3). It is noteworthy that this chapter is largely inspired by the excellent minireview of Pierre Audebert and Fabien Miomandre, published in Chemical Science in 2013 [33].

2.2 Conventional fluorescence spectroelectrochemistry cells

2.2.1 Fluorescence spectroelectrochemical cells

The general principle of the fluorescence spectroelectrochemical technique is to visualize in situ, simultaneously, the electrical (current) and the spectral (fluorescence) responses of a molecular system close to the surface of a working electrode surface subjected to both a linear or staircase potential modulation and an incident monochromatic light [14,34].

Despite a seemingly simple principle, the F-SEC has received less attention than its absorption counterpart (*i.e.* absorption spectroelectrochemistry (A-SEC)) for investigating molecular systems. While sharing a common principle, this is essentially due to the difficulties to design specific dedicated cells.

Actually, this technique requires that the immediate vicinity of the working electrode or the electrode surface itself must be in interaction with the excitation light. This also implies that the optical path of the light beams must not be disturbed by the elements present in the cell, such as counter and reference electrodes for example. Finally, the cell has to be fully compatible with the ideal 90°

detection angle, between the excitation and the emission light beams, required for luminescence measurements in order to limit the quantity of excitation light reaching the detector [12].

Over years, cells have been designed according to technologies available at that time and to the specific experimental conditions. This chapter lists the most used and the most effective solutions selected among the most promising [35-38].

Optically Transparent Thin Layer Electrochemical (OTTLE) Cells

The first set-up designed to generate interpretable results were "Optically Transparent Thin Layer Electrochemical" (OTTLE) cells, which have been recurrently used for A-SEC [39]. The later presents the advantages to work with small volume and with a high (Surface/Volume)_{exposed} ratio, thus achieving rapid electrolysis of the bulk solution confined in a pathway of *ca* 250 μm . However, cells cannot make real time resolved spectroelectrochemistry due to the presence of a non-negligible diffusion layer.

In practice, this type of cells was built with working electrodes based on vapour-deposited metallic films [40], transparent conducting oxides films [40,41] or presented small holes in its surface [42] such as for example, minigrid electrodes [43-46,2,47]. In addition, the PVD technique has the advantages of producing reproducible metallic surfaces with high crystallographic quality, low roughness, low electrical resistance and with a defined geometry [15]. With this technique, optically transparent electrodes are prepared with ease.

The experimental configuration is set with a cell positioned with a 45° angle vs. both excitation and emission beams. This configuration gives, in the case of thin layers (\approx 250 μm), a maximum emission intensity combined with minimal interference regarding to the excitation radiation and satisfy the 90° detection angle between the excitation and the emission light beams [40,12]. A schematic of possible cell configuration is depicted in Figure 1.

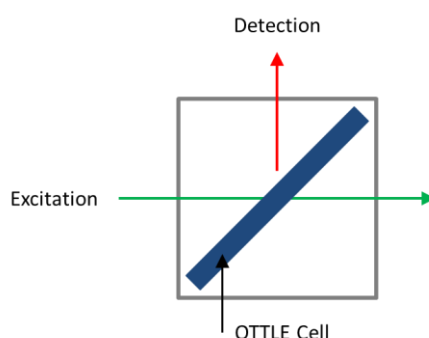

Figure 1: Schematic representation of a spectroelectrochemical experiment using OTTLE cell with minigrid or vapour-deposited metal film working electrode.

Despite results in agreement with the potential of F-SEC in term of sensitivity, the fluorescence detection is mainly limited by the light scattering from the front face of the cell leading to a low signal-to-noise ratio and to poor reproducibility.

Long Optical Path Electrochemical Cells

To overcome limitations encountered with OTTLE cells, e.g. short pathway inducing low signal intensities, "Long Optical Path Electrochemical" (LOPE) cells based on gold resinate film electrode [48] or reticulated vitreous carbon electrode (RVC) [49-51] were designed [Figure 2]. Their configuration permitted detection of the emitted light at 90°, and avoid scattering effect from the faces of the cell. Unfortunately, the equilibration time is longer than the one required for OTTLE cells and shows the pseudo-thin-layer nature of the long optical path electrochemical cells. However, bunch of experiments can be easily performed with this type of cells, particularly for stable electroactive species.

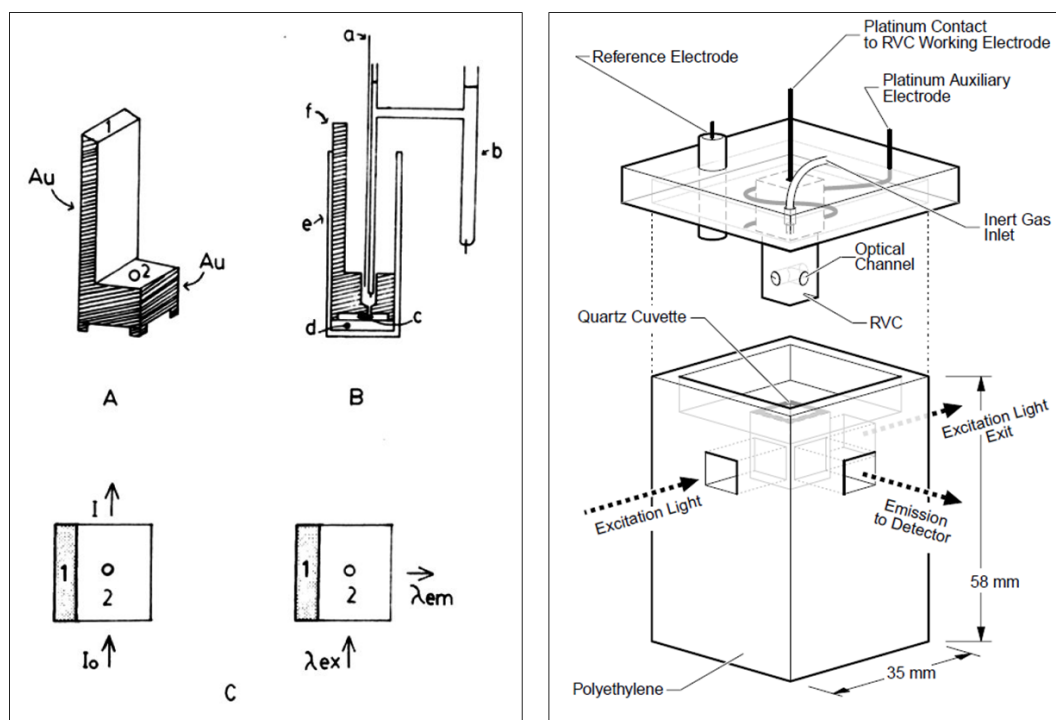

Figure 2: (Left) (A) Gold coated Teflon working electrode insert, areas 1 and 2 as in C. (B) Completed cell diagram showing (a) Pt auxiliary electrode, (b) SCE reference electrode. (c) Radiation path, (d) Teflon bottom spacer, (e) Quartz cuvette, and (f) Gold-coated Teflon working electrode. (C) Top view of the cell showing radiation paths in absorption and fluorescence experiments, areas 1 and 2 as in A (from reference [48]). (Right) Design of a two-body spectrofluorochemical cell with right angle detection (from ref. [51]).

Hydrodynamic voltammetry

Following on from cells mainly limited to stable species, OTTLE Cells have been redesigned by Compton *et al.* to work as flow cells (Figure 3), in hydrodynamic voltammetry experiments especially for complex electrochemical processes [52-54]. Hydrodynamic voltammetry techniques using such cells facilitate the analysis of fluorescent solution-phase electrogenerated species, by modelling, from a proposed model, their spacial and temporal distributions in the flow cell, and finally correlate the fluorescence intensity to the electrode current.

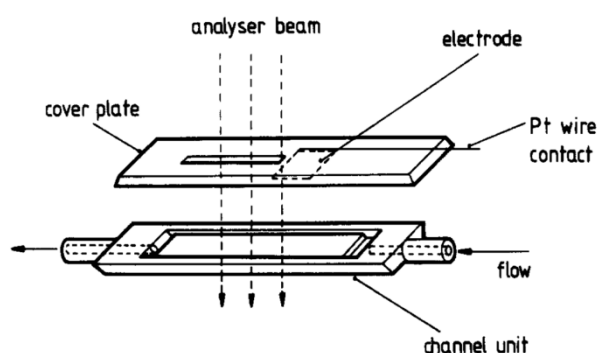

Figure 3: The channel electrode luminescence cell from reference [52].

Variable thickness Thin Layer Cells

In the beginning of 2000s, a new evolution of thin layer electrochemical cells, able to operate at variable thicknesses, were designed. A first version [55], dedicated to UV-Vis and fluorescence spectroscopies, was proposed by Yu *et al.* and is composed of a working electrode disk inserted normally to the emission detector, in a Teflon body up to an experimental chamber. The Excitation light and the emission detector were placed at 90° to each other. This type of flow cell is illustrated in Figure 4.

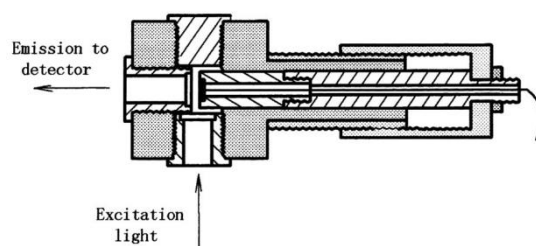

Figure 4: Schematic diagram of the thin layer spectroelectrochemical cell from reference [55].

A second version, proposed by Levillain *et al.* [14,25] and inspired by the works of Salbeck [56] and Wertz [44], can be used in different configurations due to its wide versatility and dedicated to UV-

Vis, IR or fluorescence spectroscopies. Regarding to F-SEC, the excitation light makes a 30, 45 or 60° angle with the electrode surface and the emission light is recorded normal to the surface. The path length can range from few micrometres (thin layer conditions) to few millimetres (diffusion layer conditions). This type of spectroelectrochemical cell is highlighted in Figure 5. These two examples show that the transparent electrodes are replaced by commonly used non-transparent electrodes such as gold, vitreous carbon, platinum. Recently, Levillain *et al.* have proposed to record simultaneously both the excitation and emission lights, with a zero angle configuration vs. both excitation and detection directions [15]. They can observe two concomitant processes namely the extinction of fluorescence and the inevitable increasing of the absorbance at the wavelength of the excitation light. This set-up allows performing a fluorescence and absorption spectroelectrochemistry without tuning the configuration of the bench.

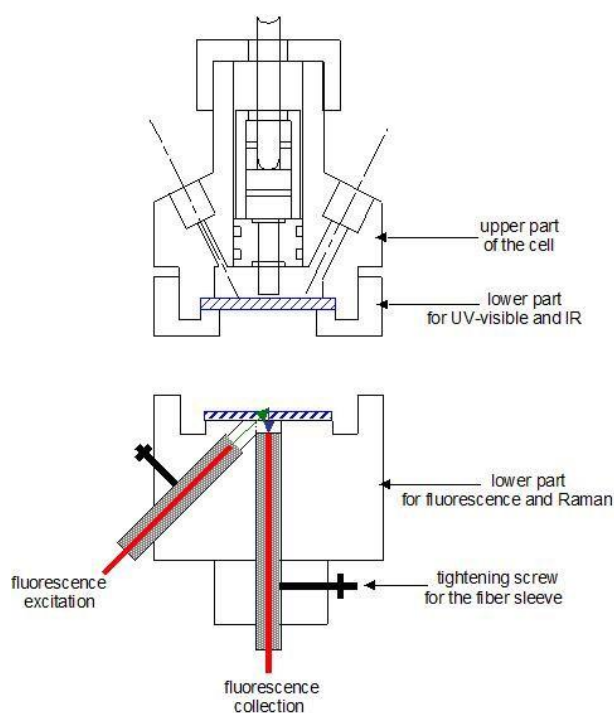

Figure 5: Schematic view of the spectroelectrochemical cell from reference [25].

2.2.2 Data processing

The improvement in cameras (*i.e.* very sensitive and stable with low noise and large dynamics), sources (*i.e.* stability vs time), optical fibers and 3D printing technologies enables now the development of very efficient time-resolved spectroelectrochemical measurement bench capable of:

- An accurate monitoring of the evolution of the spectroscopic signature as a function of an electrical perturbation such as a potential step or linear scan.

- A recording of the emission light with a non-zero or a zero angle vs. both the excitation and detection directions.
- A probing of very low intensity signals at high signal-to-noise ratio.

A-SEC and F-SEC:

Since the fluorescence intensity (I_{Fluo}) depends on the absorbance (A) (Table 1), F-SEC is closely linked to A-SEC. Set-up capable of carrying out these two techniques in parallel emerge in literature and allow an overall view of the optical and fluorescent properties under potential. This approach offers more flexibility and gives a comprehensive overview of emission and absorption processes (Figure 6).

	Solution	Modified electrode
Absorbance	$A = \epsilon \ell C$ with $\epsilon, \text{mol}^{-1}\text{L cm}^{-1}$ ℓ, cm^{-1} $C, \text{mol L}^{-1}$	$A = 1000 \epsilon \Gamma$ with $\epsilon, \text{mol}^{-1}\text{L cm}^{-1}$ $\Gamma, \text{mol cm}^{-2}$ (Γ is the surface coverage)
Fluorescence	$I_{\text{Fluo}} = k \phi I_{\text{Exc}} [1 - e^{-A}]$ with k , instrument constant ϕ , fluorescence quantum yield I_{Exc} , intensity of excitation light	

Table 1: Usual relationships between fluorescence and absorbance

Voltafluorogram and voltabsorptogram:

Even though it is well-established since a while that derivative cyclic voltabsorptogram (DCVA = dA/dt versus potential) is an efficient tool for characterizing optical properties under potential, the pioneering work dedicated to derivative cyclic voltafluorograms (DCVF) was only published in 2004 [25]. The high performance of cameras allows now calculating the derivative of the fluorescence (or absorbance) signal from a three-dimensional representation [potential (or time), wavelength, signal] and then extracting the DCVF (or DCVA) at any potential (or time) (Figure 6). In this regard, it is worth reminding here that a good signal-to-noise ratio is a prerequisite to extract, with or without smoothing *via* 1D or 2D digital filters, the derivative of the fluorescence vs. potential (or time).

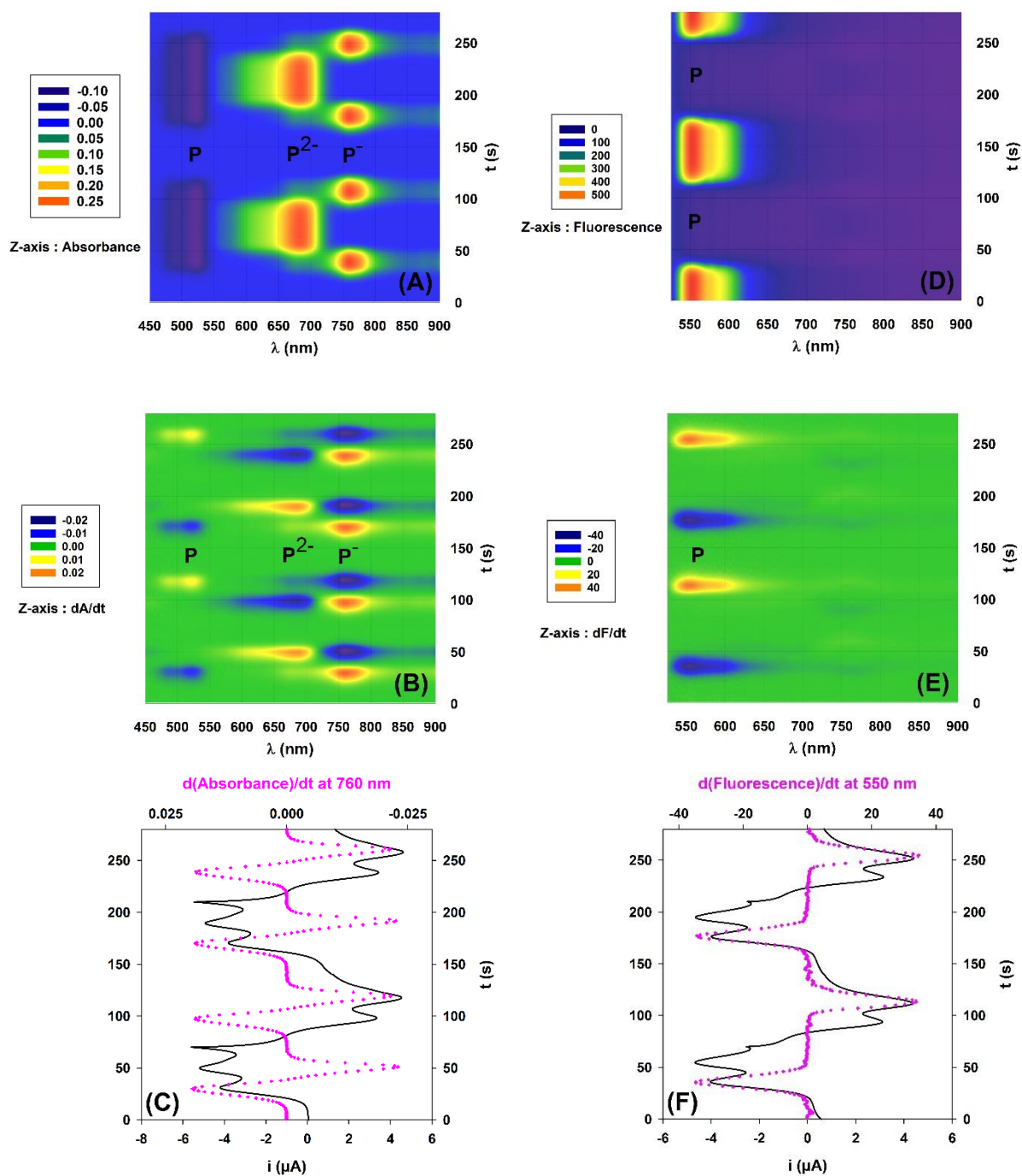

Figure 6: Absorbance and F-SEC of 5.10^{-4} M perylene-3,4,9,10-tetracarboxylic diimide (P) on Pt electrode in 0.1 M TBAPF₆ in CH₂Cl₂ in TLCV ($\sim 50 \mu\text{m}$). **(A).** 3D representation: X-axis = wavelength, Y-axis = time and Z-axis = absorbance. **(B).** 3D DCVA representation: Z-axis = dA/dt . **(C).** Unfolded CV vs. time at 5 mV.s⁻¹ and absorbance at 550 nm extracted from (B). **(D).** 3D representation: Z-axis = fluorescence intensity. Excitation at 495 nm and detection by reflection on Au electrode between 380 and 980 nm. **(E).** 3D DCVF representation: Z-axis = dF/dt . **(F).** CV at 10 mV.s⁻¹ and fluorescence intensity at 550 nm extracted from (B). Note that these results have not been published because these experiments are the same as those described in reference [25] but performed with the set-up of reference [15,57].

Simultaneous recording of excitation and emission lights:

The change of the redox state of fluorescent species occurring during a spectroelectrochemical experiment in thin layer conditions typically leads to two concomitant processes namely the fluorescence quenching and the unavoidable increasing of the absorbance at the wavelength of the excitation light ($\lambda_{\text{excitation}}$). The monitoring of both the excitation and the emission processes affords the opportunity of improving the measurement chain. The best setup is a simultaneous recording of the excitation and emission lights with a zero angle vs. excitation and detection directions (Figure 6). Moreover, it is noteworthy that, with this set-up, no configuration change is necessary to perform A-SEC experiments.

Monitoring very low signals:

Since the frantic development of nanoscale materials requires very sensitive characterizations, monitoring very low signals by spectroelectrochemistry rapidly becomes a challenge.

To illustrate, consider the "worst-case" nanomaterial of all: the self-assembled monolayer (SAM) with a surface coverage typically close to 10^{-10} mol.cm⁻².

A simple numerical calculation from Beer's law shows that the absorbance on a monolayer is, by nature, very low (close to 0.001 with $\Gamma = 10^{-10}$ mol.cm⁻² and $\epsilon = 10\ 000$ M⁻¹.cm⁻¹). However, a recent work has demonstrated that it is possible to perform a visible-NIR time-resolved spectroelectrochemistry on SAMs with a high molar attenuation coefficient chromophore, through the study of the oxidation of a 5,5'-disubstituted-2,2'-bithiophene immobilized on Au substrate [15].

For a fluorescence emission, we are facing the same problem. A numerical calculation confirms that, at the best, $I_{\text{Fluo}} = 10^{-3} I_{\text{Exc}}$ with $\Gamma = 10^{-10}$ mol.cm⁻², $\epsilon = 10\ 000$ M⁻¹.cm⁻¹, $\phi = 100\%$ and $k = 1$ (*i.e.* a fluorophore with a high fluorescence quantum yields is required). Because the molecular luminescence on SAM is, in agreement with the classical energy transfer theory, quenched by a metallic substrate, a F-SEC may not be performed on SAM. However, it is possible to reach a SAM situation under thin layer conditions. Figure 7 provides evidence of an emission spectroelectrochemistry of a perylenediimide (*i.e.* $\epsilon = 50\ 000$ M⁻¹.cm⁻¹ and $\phi = 100\%$) in solution under drastic conditions (*i.e.* a 50 μm thin layer at 10^{-4} M, corresponding to a $5 \cdot 10^{-10}$ mol.cm⁻² surface coverage).

All these results illustrate the benefits provided by the latest technological breakthroughs and offer promising prospects to probe nanomaterials by absorption and emission spectroelectrochemistry.

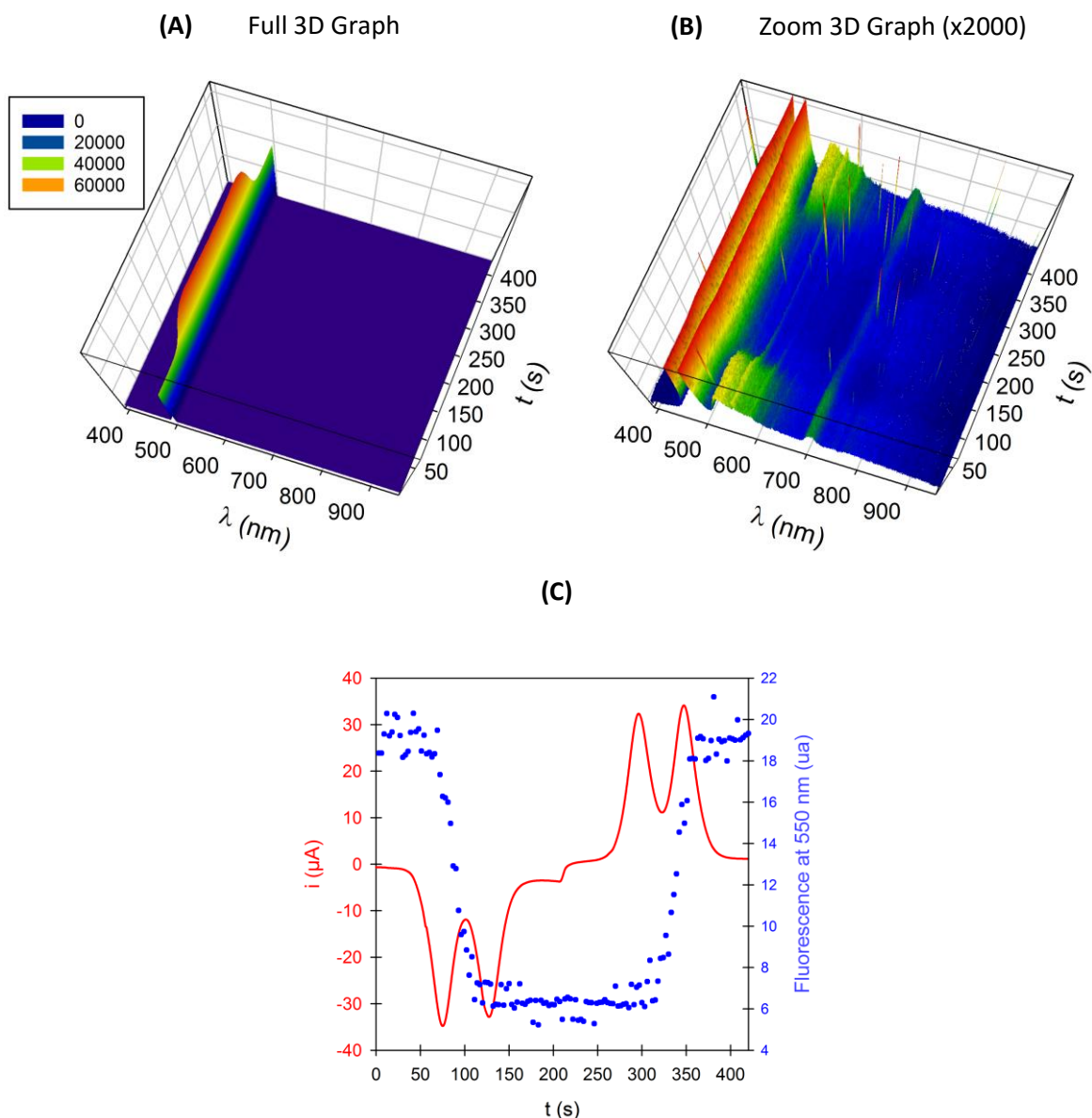

Figure 7: F-SEC of 10^{-4} M perylenediimide on Pt electrode in 0.1 M TBAPF₆ in CH₂Cl₂ characterized in a thin layer close to 50 μm, corresponding to a SAM with a surface coverage close to $5 \cdot 10^{-10}$ mol.cm⁻². Excitation at 495 nm and detection by reflection on Au electrode between 380 and 980 nm. **(A)**. 3D representation: X-axis = wavelength, Y-axis = time and Z-axis = fluorescence intensity. **(B)**. Zoom of 3D representation (raw data without smoothing via a 2D filter). As expected, the intensity ratio $i_{\text{Fluo}} / i_{\text{Exc}}$ ($15 / 60\,000$) is very small $2.5 \cdot 10^{-4}$. **(C)**. CV at $5 \text{ mV}\cdot\text{s}^{-1}$ and fluorescence intensity at 550 nm extracted from (B) vs. frames. As expected, the first reduction of the perylene moiety turns the fluorescence off. Note that these results have not been published because these experiments are the same as those described in reference [25] but performed with the set-up of the reference [15].

2.3 Electrochemistry and fluorescence microscopy coupling.

The coupling of electrochemical techniques with fluorescence microscopy is very recent compared to the conventional F-SEC previously described in the precedent part.

The development of the electrochemistry and fluorescence microscopy coupling (TIRF and confocal configuration) is mainly due to the very high sensitivity of optical detection involved in the fluorescence microscopy benches that can be pushed to the single molecule detection. In most cases, the electrochemical technique is only devoted to tune the redox state of the fluorescent molecules.

One of the most important challenges relies in detecting single-molecular fluorescence under electrochemical conditions [58].

2.3.1 Fluorescence detection

The laser-induced fluorescence spectroscopy technique is typically involved for fluorescence detection. The latter is mainly composed of three different experimental setups when coupled to a microscope: (1) classical fluorescence microscopy (epifluorescence), (2) confocal fluorescence microscopy and (3) total internal reflection fluorescence microscopy (TIRFM). Schematics of these three configurations are depicted in Figure 8.

Epifluorescence

In this configuration, excitation of the fluorophore and detection of the emitted fluorescence are performed through the same light path. The monochromatic excitation light goes through the microscope lens to be focused on the sample. Fluorescence is collected in the same direction as the excitation (*i.e.* through the objective), normal to the sample, and separated from it in the detection line by dichroic mirrors and filters.

Confocal fluorescence microscopy

Confocal microscopy increases the optical resolution (axial and lateral) and contrast of classical microscopes by adding a spatial pinhole placed at the confocal plane of the lens in order to eliminate light coming out of the focus plane. The fluorescence is thus spatially probed and is only coming from the focal plane. It enables the reconstruction of three-dimensional images from those obtained at different focal planes.

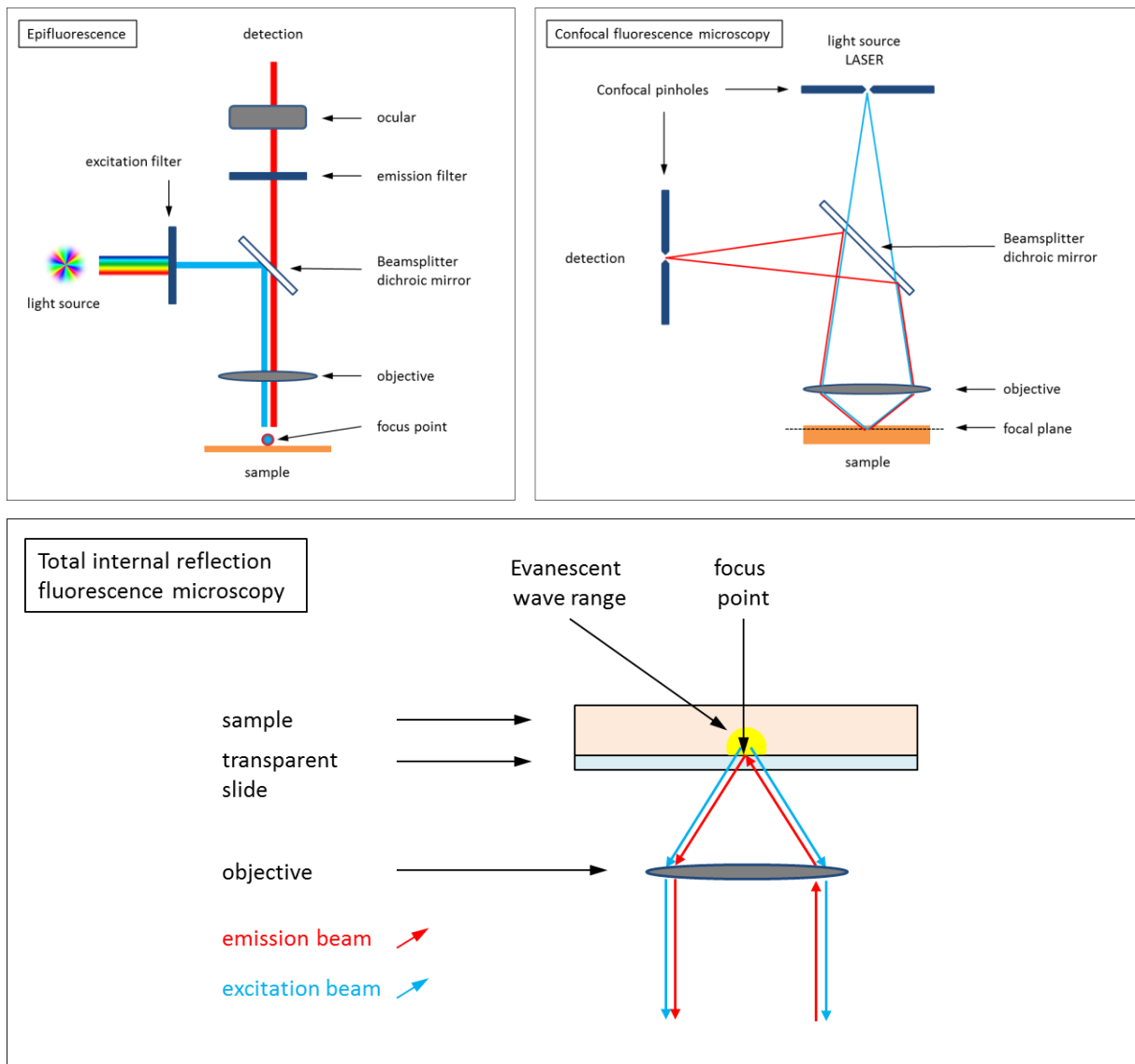

Figure 8: Schematics configurations of classical fluorescence microscopy (epifluorescence - **top left**), confocal fluorescence microscopy (**top right**) and total internal reflection fluorescence microscopy (TIRFM - **bottom**).

Total internal reflection fluorescence microscopy (TIRFM)

A total internal reflection fluorescence microscope (TIRFM) is a type of microscope in which only a restricted region of the sample can be observed near the glass-solution interface.

To reach these special conditions, the excitation light hits the sample with an incident angle greater than the critical angle determined by refraction laws. In this case, a total reflection of the incident light occurs at the glass-solution interface, and an induced evanescent wave is generated at the interface. The evanescent intensity decays exponentially from the interface, and thus penetrates into the sample to a depth of approximately a few of hundreds of nanometers. This very thin probed thickness leads to a very good axial resolution in the perpendicular direction to the interface.

2.3.2 Coupling setup

The most promising spectroelectrochemistry cells are used in combination with total internal reflection fluorescence microscopy, consequently the non-exhaustive examples of setups listed below are mostly based on this configuration.

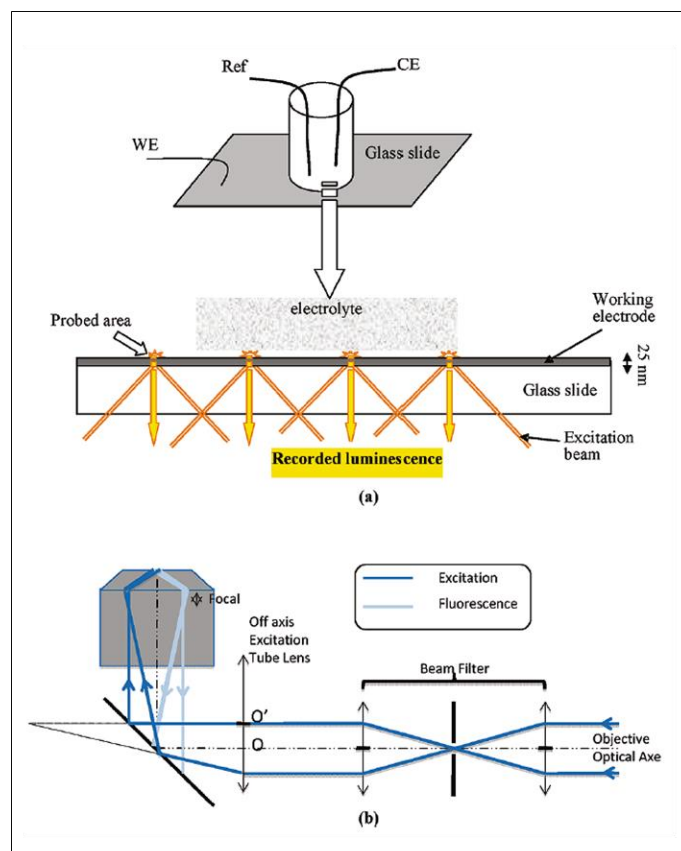

Figure 9: (a) Scheme of the Electrochemical Cell (Top) and Platinum Coated Microscope Slide Used for TIRF Measurements (Bottom) and (b) Optical Path for the Excitation and Emitted Beams in the Epifluorescence Set-Up. From reference [59].

The first example of fluorescence microscopy coupled to a three-electrode electrochemical, reported by Audebert and Miomandre [24,47,59], was dedicated to the investigation of a controlled-potential redox switch of organic fluorophores (Figure 9). The three-electrode cell was composed of a working electrode made with platinum thin layer coated on a microscope glass slide. In order to produce valuable information about quenching mechanisms during a redox state change event, the lifetime variations along with the fluorescence intensity have been measured via the implementation of a pulsed laser to the microscope (Figure 10). Confocal fluorescence microscopy and total internal

reflection fluorescence microscopy were adapted to the electrochemical cell to probe the fluorescence emission.

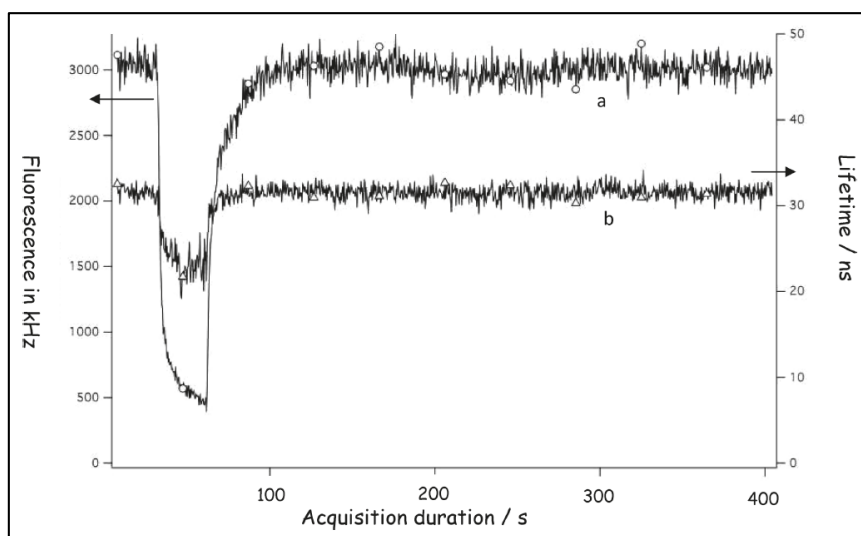

Figure 10: Evolution of the fluorescence lifetime of tetrazine dye (right scale) along with the fluorescence intensity (left scale) for a double step potential between 0 and -0.85 V. From reference [59].

A similar bench (Figure 11) was proposed by Ackerman et al in a confocal fluorescence microscopy configuration [60,61]. The spatial/temporal resolution of this technique combined with a nanomolar concentration of active molecule permit to detect single events as "bursts" in the modulated signal.

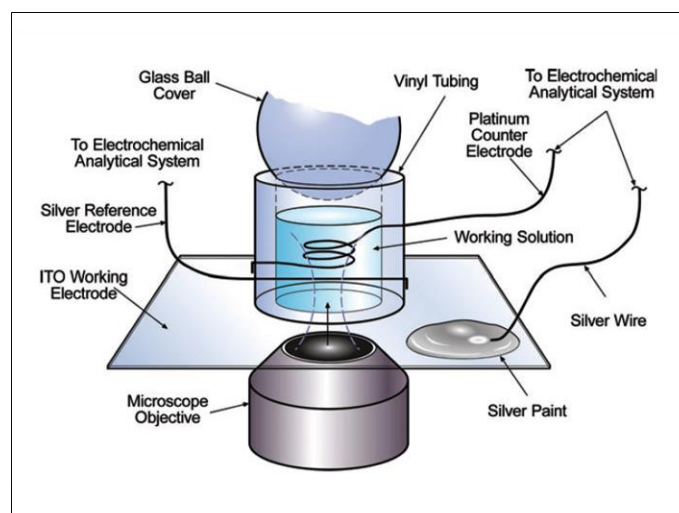

Figure 11: Schematic of an electrochemical cell coupled with scanning confocal fluorescence microscopy from reference [60].

This study shows that it is *a priori* possible with this method to identify the fluorescence of single molecules. Thus, molecular electrochemical characteristics such as standard potentials and electron transfer kinetics may be determined with a similar method. This was accomplished with specific molecules designed to allow energy transfer to be modulated by the electrode potential as for example when the redox active fluorophore was adsorbed on nanoparticles [61,62], when the redox center was connected to a fluorescent molecule as a protein [63], or when the active molecule is a part of a polymer with high molecular weight [58].

Voltafluorograms show that the fluorescence intensity varies with the potential with the same trend as the electrochemical current [62-64]. Compared to other techniques, the spatial resolution of fluorescence microscopy (image of few microns) ranks this technique among the most promising for the future.

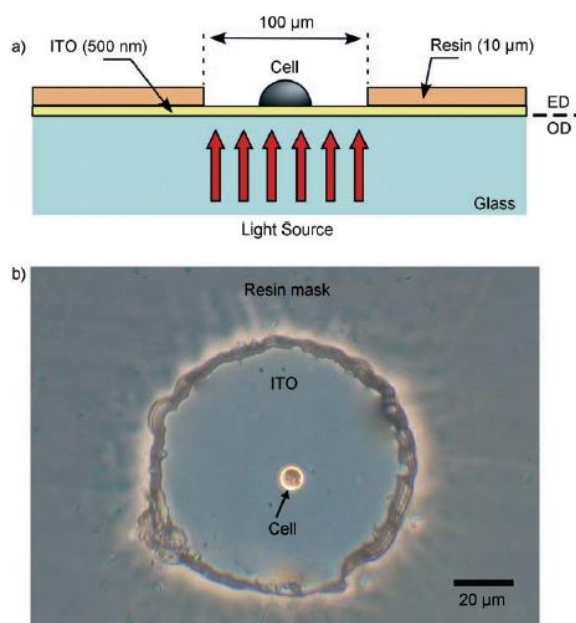

Figure 12: a) Schematic vertical cross-section of an ITO microelectrode. The electrochemical detection (ED) is performed on the ITO surface (upper part of the device) while the optical detection (OD) is obtained through the glass and ITO (lower part). b) Photograph (inverted microscopy) of a chromaffin cell adhering to an ITO microelectrode (100 mm diameter); the insulating resin appears as the dark gray external area. From reference [64].

Recently, thermodynamics and kinetics of electron transfer of single immobilized particles have been determined based on single-molecule spectroelectrochemistry (SMS-EC) [58], this new technique reported by Palacios and co-workers is based on total internal reflection fluorescence microscopy.

Last but not least, another promising method consists of using microelectrodes combined with total internal reflection fluorescence microscopy. Indeed, Amatore et al. [64] have reported the real-time observation of fluorescence and amperometric measurements of exocytosis events at single biologic cell on transparent indium tin oxide (ITO) microelectrodes (Figure 12). Similar investigations were done using microfluidic configuration [65].

2.3 Conclusion

Over the last decade, the benefits provided by the latest technological breakthroughs have improved the instrumental setup dealing with electrofluorochromism, *i.e.* electrochemical monitoring of the fluorescence properties.

Nowadays, the technology facilities are no longer a hindrance to the development of emission spectroelectrochemistry and offers promising prospects in forthcoming research on fluorescent molecules, materials and devices. In the reasonably near future, significant improvements in the miniaturization of the devices should emerge since it is now possible to follow very low absorption and emission events, up to the detection of a single molecule. For example, in analytical and bioanalytical chemistry, many analytes are redox active and could be detected and mapped with a high sensitivity through fluorescence via nanosensors.

2.4 Acknowledgment

The authors thank Flavy Alévêque and Dr. Clément Cabanetos for their critical readings of the manuscript.

References

1. Blubaugh EA, Yacynych AM, Heineman WR (1979) THIN-LAYER SPECTROELECTROCHEMISTRY FOR MONITORING KINETICS OF ELECTROGENERATED SPECIES. *Analytical Chemistry* 51 (4):561-565. doi:10.1021/ac50040a026
2. Kaim W, Fiedler J (2009) Spectroelectrochemistry: the best of two worlds. *Chemical Society Reviews* 38 (12):3373-3382. doi:10.1039/b504286k
3. Dunsch L (2011) Recent Advances in in situ multi-spectroelectrochemistry. *Journal of Solid State Electrochemistry* 15 (7-8):1631-1646. doi:10.1007/s10008-011-1453-1
4. Melin F, Hellwig P (2013) Recent advances in the electrochemistry and spectroelectrochemistry of membrane proteins. *Biological Chemistry* 394 (5):593-609. doi:10.1515/hsz-2012-0344
5. Pruiksma R, McCreery RL (1979) OBSERVATION OF ELECTROCHEMICAL CONCENTRATION PROFILES BY ABSORPTION SPECTROELECTROCHEMISTRY. *Analytical Chemistry* 51 (13):2253-2257. doi:10.1021/ac50049a045
6. Skully JP, McCreery RL (1980) GLANCING INCIDENCE EXTERNAL REFLECTION SPECTROELECTROCHEMISTRY WITH A CONTINUUM SOURCE. *Analytical Chemistry* 52 (12):1885-1889. doi:10.1021/ac50062a025
7. Robinson RS, McCreery RL (1981) ABSORPTION SPECTROELECTROCHEMISTRY WITH MICROELECTRODES. *Analytical Chemistry* 53 (7):997-1001. doi:10.1021/ac00230a017
8. Brewster JD, Anderson JL (1982) FIBER OPTIC THIN-LAYER SPECTROELECTROCHEMISTRY WITH LONG OPTICAL-PATH. *Analytical Chemistry* 54 (14):2560-2566. doi:10.1021/ac00251a035
9. Robinson RS, McCurdy CW, McCreery RL (1982) MICROSECOND SPECTROELECTROCHEMISTRY BY EXTERNAL REFLECTION FROM CYLINDRICAL MICROELECTRODES. *Analytical Chemistry* 54 (13):2356-2361. doi:10.1021/ac00250a049
10. Bard AJ, Faulkner LR, Brisset JL (1983) *Electrochimie: principes, méthodes et applications*. Masson,
11. Bard AJ, Faulkner LR (2000) *Electrochemical Methods: Fundamentals and Applications*. Wiley,
12. Zoski CG (2007) *Handbook of Electrochemistry*. Elsevier,
13. Kaim W, Klein A (2008) *Spectroelectrochemistry*. Royal Society of Chemistry,
14. Gaillard F, Levillain E (1995) VISIBLE TIME-RESOLVED SPECTROELECTROCHEMISTRY - APPLICATION TO STUDY OF THE REDUCTION OF SULFUR (S-8) IN DIMETHYLFORMAMIDE. *Journal of Electroanalytical Chemistry* 398 (1-2):77-87. doi:10.1016/0022-0728(95)04144-1
15. Aleveque O, Levillain E, Sanguinet L (2015) Spectroelectrochemistry on electroactive self-assembled monolayers: Cyclic voltammetry coupled to spectrophotometry. *Electrochemistry Communications* 51:108-112. doi:10.1016/j.elecom.2014.12.014
16. Neudeck A, Dunsch L (1994) CYCLIC VOLTAMMETRY AT MICROSTRUCTURED ELECTRODES. *Journal of Electroanalytical Chemistry* 370 (1-2):17-32. doi:10.1016/0022-0728(93)03206-5
17. Neudeck A, Dunsch L (1995) MICROSTRUCTURED ELECTRODE MATERIALS IN UV-VISIBLE SPECTROELECTROCHEMISTRY. *Journal of Electroanalytical Chemistry* 386 (1-2):135-148. doi:10.1016/0022-0728(95)03824-z
18. Niu JJ, Dong SJ (1996) Transmission spectroelectrochemistry. *Reviews in Analytical Chemistry* 15 (1-2):1-171
19. Frank O, Dresselhaus MS, Kalbac M (2015) Raman Spectroscopy and in Situ Raman Spectroelectrochemistry of Isotopically Engineered Graphene Systems. *Accounts of Chemical Research* 48 (1):111-118. doi:10.1021/ar500384p
20. Gaillard F, Levillain E, Dhamelinourt MC, Dhamelinourt P, Lelieur JP (1997) Polysulphides in dimethylformamide: A micro-Raman spectroelectrochemical study. *Journal of Raman Spectroscopy* 28 (7):511-517. doi:10.1002/(sici)1097-4555(199707)28:7<511::aid-jrs119>3.3.co;2-w
21. Bellec V, De Backer MG, Levillain E, Sauvage FX, Sombret B, Wartelle C (2001) In situ time-resolved FTIR spectroelectrochemistry: study of the reduction of TCNQ. *Electrochemistry Communications* 3 (9):483-488. doi:10.1016/s1388-2481(01)00158-8

22. Wartelle C, Viruela PM, Viruela R, Orti E, Sauvage FX, Levillain E, Le Derf F, Salle M (2005) A study by spectroelectrochemical FTIR and density functional theory calculations of the reversible complexing ability of an electroactive tetrathiafulvalene crown. *Journal of Physical Chemistry A* 109 (6):1188-1195. doi:10.1021/jp045397y
23. Ashley K, Pons S (1988) INFRARED SPECTROELECTROCHEMISTRY. *Chemical Reviews* 88 (4):673-695. doi:10.1021/cr00086a006
24. Miomandre F, Meallet-Renault R, Vachon J-J, Pansu RB, Audebert P (2008) Fluorescence microscopy coupled to electrochemistry: A powerful tool for the controlled electrochemical switch of fluorescent molecules. *Chemical Communications* (16):1913-1915. doi:10.1039/b718899d
25. Dias M, Hudhomme P, Levillain E, Perrin L, Sahin Y, Sauvage FX, Wartelle C (2004) Electrochemistry coupled to fluorescence spectroscopy: a new versatile approach. *Electrochemistry Communications* 6 (3):325-330. doi:10.1016/j.elecom.2004.01.010
26. Petr A, Dunsch L, Neudeck A (1996) In situ UV-vis ESR spectroelectrochemistry. *Journal of Electroanalytical Chemistry* 412 (1-2):153-158. doi:10.1016/0022-0728(96)04582-2
27. Rapta P, Neudeck A, Petr A, Dunsch L (1998) In situ EPR/UV-VIS spectroelectrochemistry of polypyrrole redox cycling. *Journal of the Chemical Society-Faraday Transactions* 94 (24):3625-3630. doi:10.1039/a806423g
28. Sharpe LR, Heineman WR, Elder RC (1990) EXAFS SPECTROELECTROCHEMISTRY. *Chemical Reviews* 90 (5):705-722. doi:10.1021/cr00103a002
29. Dong SJ, Niu JJ, Cotton TM (1995) ULTRAVIOLET-VISIBLE SPECTROELECTROCHEMISTRY OF REDOX PROTEINS. *Biochemical Spectroscopy* 246:701-732
30. Taboy CH, Bonaventura C, Crumbliss AL (2002) Anaerobic oxidations of myoglobin and hemoglobin by spectroelectrochemistry. *Redox Cell Biology and Genetics, Pt B* 353:187-209
31. Murgida D, Hildebrandt P (2006) Surface-enhanced vibrational spectroelectrochemistry: Electric-field effects on redox and redox-coupled processes of heme proteins. *Surface-Enhanced Raman Scattering: Physics and Applications* 103:313-334
32. Best SP (2005) Spectroelectrochemistry of hydrogenase enzymes and related compounds. *Coordination Chemistry Reviews* 249 (15-16):1536-1554. doi:10.1016/j.ccr.2005.01.012
33. Audebert P, Miomandre F (2013) Electrofluorochromism: from molecular systems to set-up and display. *Chemical Science* 4 (2):575-584. doi:10.1039/c2sc21503a
34. Heineman WR (1983) Spectroelectrochemistry: The combination of optical and electrochemical techniques. *Journal of Chemical Education* 60 (4):305. doi:10.1021/ed060p305
35. Kim Y, Kim E, Clavier G, Audebert P (2006) New tetrazine-based fluoro-electrochromic window; modulation of the fluorescence through applied potential. *Chemical Communications* (34):3612-3614. doi:10.1039/b608312a
36. Schroll CA, Chatterjee S, Heineman WR, Bryan SA (2012) Thin-Layer Spectroelectrochemistry on an Aqueous Microdrop. *Electroanalysis* 24 (5):1065-1070. doi:10.1002/elan.201100711
37. Voicescu M, Rother D, Bardischewsky F, Friedrich CG, Hellwig P (2011) A Combined Fluorescence Spectroscopic and Electrochemical Approach for the Study of Thioredoxins. *Biochemistry* 50 (1):17-24. doi:10.1021/bi1013112
38. Brisendine JM, Mutter AC, Cerda JF, Koder RL (2013) A three-dimensional printed cell for rapid, low-volume spectroelectrochemistry. *Analytical Biochemistry* 439 (1):1-3. doi:<http://dx.doi.org/10.1016/j.ab.2013.03.036>
39. Kuwana T, Darlington RK, Leedy DW (1964) Electrochemical Studies Using Conducting Glass Indicator Electrodes. *Analytical Chemistry* 36 (10):2023-2025. doi:10.1021/ac60216a003
40. Yildiz A, Kissinger PT, Reilly CN (1968) Evaluation of an improved thin-layer electrode. *Analytical Chemistry* 40 (7):1018-1024. doi:10.1021/ac60263a012
41. Wilson RA, Pinyayev TS, Membreno N, Heineman WR (2010) Rapid Prototyped Optically Transparent Thin-Layer Electrode Holder for Spectroelectrochemistry in Bench-Top Spectrophotometers. *Electroanalysis* 22 (19):2162-2166. doi:10.1002/elan.201000267

42. Compton RG, Fisher AC, Wellington RG (1991) A THIN-LAYER ELECTRODE CELL FOR FLUORESCENCE MEASUREMENTS ON ELECTROGENERATED INTERMEDIATES. *Electroanalysis* 3 (1):27-29. doi:10.1002/elan.1140030105
43. Simone MJ, Heineman WR, Kreishman GP (1982) Preliminary spectrofluorochemical studies indicate a possible conformational change in horse heart cytochrome c upon reduction. *Journal of Colloid and Interface Science* 86 (2):295-298. doi:[http://dx.doi.org/10.1016/0021-9797\(82\)90075-3](http://dx.doi.org/10.1016/0021-9797(82)90075-3)
44. McLeod CW, West TS (1982) Spectroelectrochemistry of morphine and related alkaloids and their investigation by fluorescence in a gold micromesh cell. *Analyst* 107 (1270):1-11. doi:10.1039/AN9820700001
45. Jones ETT, Faulkner LR (1984) Luminescence spectroelectrochemistry in thin layer cells. *Journal of Electroanalytical Chemistry and Interfacial Electrochemistry* 179 (1):53-64. doi:[http://dx.doi.org/10.1016/S0022-0728\(84\)80274-0](http://dx.doi.org/10.1016/S0022-0728(84)80274-0)
46. Heineman WR, Norris BJ, Goelz JF (1975) Measurement of enzyme E₀' values by optically transparent thin layer electrochemical cells. *Analytical Chemistry* 47 (1):79-84. doi:10.1021/ac60351a001
47. Miomandre F, Allain C, Clavier G, Audibert J-F, Pansu RB, Audebert P, Hartl F (2011) Coupling thin layer electrochemistry with epifluorescence microscopy: An expedient way of investigating electrofluorochromism of organic dyes. *Electrochemistry Communications* 13 (6):574-577. doi:10.1016/j.elecom.2011.03.013
48. Simone MJ, Heineman WR, Kreishman GP (1982) Long optical path electrochemical cell for absorption or fluorescence spectrometers. *Analytical Chemistry* 54 (13):2382-2384. doi:10.1021/ac00250a058
49. Lee YF, Kirchhoff JR (1993) Design and characterization of a spectroelectrochemistry cell for absorption and luminescence measurements. *Analytical Chemistry* 65 (23):3430-3434. doi:10.1021/ac00071a016
50. Lee YF, Kirchhoff JR (1994) Absorption and luminescence spectroelectrochemical characterization of a highly luminescent rhenium(II) complex. *Journal of the American Chemical Society* 116 (8):3599-3600. doi:10.1021/ja00087a056
51. Kirchhoff JR (1997) Luminescence Spectroelectrochemistry. *Current Separations* 16 (1):11-14
52. Compton RG, Fisher AC, Wellington RG, Winkler J (1992) SPECTROFLUOROMETRIC HYDRODYNAMIC VOLTAMMETRY - THEORY AND PRACTICE. *Journal of Physical Chemistry* 96 (20):8153-8157. doi:10.1021/j100199a061
53. Compton RG, Wellington RG (1994) SPECTROFLUOROMETRIC HYDRODYNAMIC VOLTAMMETRY - THE INVESTIGATION OF ELECTRODE-REACTION MECHANISMS. *Journal of Physical Chemistry* 98 (1):270-273. doi:10.1021/j100052a045
54. Compton RG, Winkler J, Riley DJ, Bearpark SD (1994) SPECTROFLUOROMETRIC HYDRODYNAMIC VOLTAMMETRY - INVESTIGATION OF REACTIONS AT SOLID/LIQUID INTERFACES. *Journal of Physical Chemistry* 98 (27):6818-6825. doi:10.1021/j100078a026
55. Yu J-S, Yang C, Fang H-Q (2000) Variable thickness thin-layer cell for electrochemistry and in situ UV-VIS absorption, luminescence and surface-enhanced Raman spectroelectrochemistry. *Analytica Chimica Acta* 420 (1):45-55. doi:[http://dx.doi.org/10.1016/S0003-2670\(00\)01005-9](http://dx.doi.org/10.1016/S0003-2670(00)01005-9)
56. Salbeck J (1992) An electrochemical cell for simultaneous electrochemical and spectroelectrochemical measurements under semi-infinite diffusion conditions and thin-layer conditions. *Journal of Electroanalytical Chemistry* 340 (1-2):169-195. doi:[http://dx.doi.org/10.1016/0022-0728\(92\)80297-H](http://dx.doi.org/10.1016/0022-0728(92)80297-H)
57. Bkhach S, Le Duc Y, Aleveque O, Gautier C, Hudhomme P, Levillain E (2016) Highly stable perylene diimide based self-assembled monolayers studied by spectroelectrochemistry. *ChemElectroChem*:n/a-n/a. doi:10.1002/celec.201600034
58. Palacios RE, Fan F-RF, Bard AJ, Barbara PF (2006) Single-molecule spectroelectrochemistry (SMS-EC). *Journal of the American Chemical Society* 128 (28):9028-9029. doi:10.1021/ja062848e

59. Miomandre F, Lepicier E, Munteanu S, Galangau O, Audibert JF, Meallet-Renault R, Audebert P, Pansu RB (2011) Electrochemical Monitoring of the Fluorescence Emission of Tetrazine and Bodipy Dyes Using Total Internal Reflection Fluorescence Microscopy Coupled to Electrochemistry. *Acs Applied Materials & Interfaces* 3 (3):690-696. doi:10.1021/am100980u
60. Lei C, Hu D, Ackerman EJ (2008) Single-molecule fluorescence spectroelectrochemistry of cresyl violet. *Chemical Communications* (43):5490-5492. doi:10.1039/b812161c
61. Lei C, Hu D, Ackerman E (2009) Clay Nanoparticle-Supported Single-Molecule Fluorescence Spectroelectrochemistry. *Nano Letters* 9 (2):655-658. doi:10.1021/nl802998e
62. Galland C, Ghosh Y, Steinbruck A, Sykora M, Hollingsworth JA, Klimov VI, Htoon H (2011) Two types of luminescence blinking revealed by spectroelectrochemistry of single quantum dots. *Nature* 479 (7372):203-207.
doi:<http://www.nature.com/nature/journal/v479/n7372/abs/nature10569.html#supplementary-information>
63. Salverda JM, Patil AV, Mizzon G, Kuznetsova S, Zauner G, Akkilic N, Canters GW, Davis JJ, Heering HA, Aartsma TJ (2010) Fluorescent Cyclic Voltammetry of Immobilized Azurin: Direct Observation of Thermodynamic and Kinetic Heterogeneity. *Angewandte Chemie International Edition* 49 (33):5776-5779. doi:10.1002/anie.201001298
64. Amatore C, Arbault S, Chen Y, Crozatier C, Lemaitre F, Verchier Y (2006) Coupling of electrochemistry and fluorescence microscopy at indium tin oxide microelectrodes for the analysis of single exocytotic events. *Angewandte Chemie-International Edition* 45 (24):4000-4003. doi:10.1002/anie.200600510
65. Shi B-X, Wang Y, Lam T-L, Huang W-H, Zhang K, Leung Y-C, Chan HLW (2010) Release monitoring of single cells on a microfluidic device coupled with fluorescence microscopy and electrochemistry. *Biomicrofluidics* 4 (4):043009. doi:doi:<http://dx.doi.org/10.1063/1.3491470>