



HAL
open science

Numerical simulations of internal solitary waves interacting with uniform slopes using an adaptive model

G. Rickard, J. O'Callaghan, S. Popinet

► **To cite this version:**

G. Rickard, J. O'Callaghan, S. Popinet. Numerical simulations of internal solitary waves interacting with uniform slopes using an adaptive model. *Ocean Modelling*, 2009, 30, pp.16-28. 10.1016/j.ocemod.2009.05.008 . hal-01445433

HAL Id: hal-01445433

<https://hal.science/hal-01445433>

Submitted on 24 Jan 2017

HAL is a multi-disciplinary open access archive for the deposit and dissemination of scientific research documents, whether they are published or not. The documents may come from teaching and research institutions in France or abroad, or from public or private research centers.

L'archive ouverte pluridisciplinaire **HAL**, est destinée au dépôt et à la diffusion de documents scientifiques de niveau recherche, publiés ou non, émanant des établissements d'enseignement et de recherche français ou étrangers, des laboratoires publics ou privés.

Numerical simulations of internal solitary waves interacting with uniform slopes using an adaptive model

Graham Rickard^{a,*}, Joanne O’Callaghan^a, and
Stéphane Popinet^a

^a*National Institute of Water and Atmospheric Research, P.O. Box 14-901,
Kilbirnie, Wellington, New Zealand*

Abstract

Two-dimensional, non-linear, Boussinesq, non-hydrostatic simulations of internal solitary waves breaking and running up uniform slopes have been performed using an adaptive, finite volume fluid code “Gerris”. It is demonstrated that the Gerris dynamical core performs well in this specific but important geophysical context. The “semi-structured” nature of Gerris is exploited to enhance model resolution along the slope where wave breaking and run-up occur. Comparison with laboratory experiments reveals that the generation of single and multiple turbulent surges (“boluses”) as a function of slope angle is consistently reproduced by the model, comparable with observations and previous numerical simulations, suggesting aspects of the dynamical energy transfers are being represented by the model in two dimensions. Adaptivity is used to explore model convergence of the wave breaking dynamics, and it is shown that significant cpu memory and time savings are possible with adaptivity.

Key words: Internal wave breaking; modelling.

1 Introduction

2 Breaking internal solitary waves (ISWs) are considered to be important con-
3 tributors to the energy required for mixing in the coastal zone (see, e.g., the

* Corresponding author. Tel.: +64 4 386 0311; fax: +64 4 386 2153.

Email addresses: g.rickard@niwa.co.nz (Graham Rickard),
j.ocallaghan@niwa.co.nz (Joanne O’Callaghan), s.popinet@niwa.co.nz
(Stéphane Popinet).

4 review by Helfrich and Melville (2006) and references therein). This is sup-
5 plemented by recent observations (Bourgault et al 2007) of a train of ISWs
6 impacting a coastline; integral to the study is a model comparison since it
7 is noted that the general nature and predictability of ISWs remain largely
8 unquantified. Furthermore, parameterisation of such energetic overturning for
9 large scale models is hampered without detailed process scale modelling allied
10 to field work. To that end this paper considers how high resolution modelling
11 of such processes might be efficiently obtained using adaptive simulation tech-
12 niques.

13 In a previous paper (Popinet and Rickard, 2007) an extension of an existing
14 adaptive fluid code “Gerris” (Popinet, 2003 and 2006) for use with geophysical
15 flows was described. The main issue was to demonstrate (via a series of test
16 cases) that an “A-grid” formulation in Gerris comprising spatially collocated
17 variables that allows for the use of adaptivity would not seriously compromise
18 geophysical requirements (in particular geostrophic balance); the nature of the
19 spatial operations (“approximate projection method”) was shown to introduce
20 a small amount of damping to the inertia-gravity waves while leaving the large
21 scale flows relatively unhindered. Popinet and Rickard (2007) showed that
22 Gerris was more than competitive in this regard in comparison to other non-
23 standard ocean models. The test cases also demonstrated how the finite volume
24 grid structure provided a significant advantage when it came to resolution and
25 representation of the interaction with boundaries.

26 Although Popinet and Rickard (2007) showed the potential for a three di-
27 mensional geophysical extension of Gerris, the adaptivity was limited to the
28 horizontal plane only, with depth projection through vertical z-level stacked
29 layers. Furthermore, most of the test cases focussed on the horizontal geophys-
30 ical responses of the model. In this paper the aim is to look in more detail
31 at the vertical properties, in particular the integration of Boussinesq accelera-
32 tions into the model in the context of non-hydrostatic simulations of internal
33 solitary wave (ISW) breaking as an overall “assessment” of Gerris in the spirit
34 suggested by Berntsen et al (2006). In this paper adaptivity operates in both
35 the horizontal and vertical, removing the limitation of stacked layers.

36 Adaptive methods have long been recognised as potentially allowing efficient
37 access to the multi-scale nature of geophysical flows. Examples for structured
38 models include Blayo and Debreu (1999), and Burchard and Beckers (2004)
39 and Hanert et al (2006) for vertical processes, Behrens (2005) in the context
40 of atmospheric flows, and for unstructured models Piggott et al (2008) and
41 references therein. The examples and tests in Piggott et al (2008) illustrate
42 the adaptive potential, including both two and three dimensional flows, and
43 the issues described (particularly geophysical scale pressure interacting with
44 buoyancy) are those considered for the “semi-structured” Gerris here and by
45 Popinet and Rickard (2007).

46 The approach we will take with Gerris is that of Bourgault and Kelley (2004)
 47 (as advocated by Berntsen et al, 2006) in that a non-hydrostatic model in-
 48 tended for use at coastal scales first be validated against existing observa-
 49 tional data, in this instance the laboratory experiments of Helfrich (1992) and
 50 Michallet and Ivey (1999). Confidence in a model at these scales provides for a
 51 potential benchmark when assessing model performance at geophysical scales.

52 The motivation for this paper is to demonstrate that the collocated Gerris
 53 A-grid can indeed function readily with vertical Boussinesq accelerations and
 54 viscosity included. For the inter-model comparisons a “standard run” (see
 55 later) is used in order to allow reasonable coverage of the parameter space. In
 56 these standard runs the semi-structured Gerris grid is used to provide for en-
 57 hanced (but fixed) resolution along the sloping surface where boundary layers
 58 are anticipated to evolve. A series of simulations will also be used to explore the
 59 resolution dependence of the model solutions (both fixed and adaptive grids),
 60 and to quantify the relative efficiency of the adaptivity. The comparisons show
 61 that Gerris represents an efficient modelling tool for the investigation of the
 62 nature of bolus generation, propagation, and eventual decay as a result of the
 63 ISW breaking.

64 2 Problem definition and model tests

In this study the coordinates are (x, y, z, t) , where (x, y) and z are the horizon-
 tal and vertical coordinates, respectively, and t is time. With the Boussinesq
 approximation, the incompressible, non-hydrostatic equations in a Cartesian
 reference frame become,

$$\partial_t \mathbf{U} + \mathbf{U} \cdot \nabla \mathbf{U} = -\frac{1}{\rho_0} \nabla p - \frac{\rho'}{\rho_0} \mathbf{g} + \nu \nabla^2 \mathbf{U} \quad (1)$$

for momentum,

$$\nabla \cdot \mathbf{U} = 0 \quad (2)$$

for continuity,

$$\partial_t \rho + \mathbf{U} \cdot \nabla \rho = K \nabla^2 \rho \quad (3)$$

65 for density $\rho(x, y, z, t) = \rho_0 + \rho'(x, y, z, t)$ for constant ρ_0 , with $\mathbf{U} \equiv (u, v, w)$
 66 the components of the velocity, and the vector $\mathbf{g} = (0, 0, -1)g$ with g the
 67 constant acceleration due to gravity.

The initial model density $\rho(x, y, z, t = 0) = \rho_0 + \rho'(x, y, z)$ is set with $\rho_0 =$
 1000.0 kgm^{-3} , and

$$\rho'(x, y, z) = \frac{\Delta \rho}{2} \left(1 + \tanh \left[\frac{z - z_i - \zeta(x)}{\Delta h} \right] \right), \quad (4)$$

where,

$$\zeta(x) = 2a_i \operatorname{sech}^2\left(\frac{x}{2W}\right), \quad a_i W^2 = \frac{4(d_- d_+)^2}{3(d_- - d_+)}, \quad (5)$$

68 where x is the distance from the left hand edge of the domain. With $\zeta = 0$,
69 equation 4 establishes a pycnocline of characteristic width Δh centred about a
70 distance z_i below the top of the domain, with $\Delta\rho$ defining the change in density
71 across the pycnocline. For finite ζ a perturbation of amplitude $2a_i$ is added (see
72 the sketch in Figure 1). The aim is to establish an ISW of amplitude $a_0 = a_i$
73 propagating toward the slope. The profile mimics the initial conditions in the
74 Helfrich (1992) and Michallet and Ivey (1999) experiments, and uses functional
75 forms considered by Segur and Hammack (1982), Bogucki and Garrett (1993),
76 and Bourgault and Kelley (2003).

77 *Insert Figure 1 here*

78 The numerical scheme used by the adaptive model to solve these equations is
79 described in Appendix A. Most of the details have been presented previously
80 (e.g. Popinet (2003), and Popinet and Rickard (2007)); however, the intro-
81 duction of the Boussinesq terms interacting with viscosity in this particular
82 context represents a new extension of the adaptive model, and so it is relevant
83 to summarise the numerics.

84 For the present experiments, no normal flux conditions apply to the side and
85 bottom surfaces. No-slip boundary conditions apply on the bottom boundary
86 (both the level run-up of length L_R in Fig. 1, and the slope), while free slip
87 conditions apply to the left hand boundary. There is no bottom friction. The
88 top boundary is a rigid lid. Unlike Bourgault and Kelley (2007) we do not
89 consider the impact of a sidewall friction that they are able to use in their
90 laterally-averaged model. To that end our runs are purely two dimensional
91 (i.e., the “free-slip side walls” as described by Bourgault and Kelley (2007)).

92 2.1 Model “standard run”

93 To be able to explore the parameter space observed by Helfrich (1992) and
94 Michallet and Ivey (1999), and to be able to provide comparison with other
95 model solutions, a “standard run” (see below) is defined. Adaptivity will be
96 used later to explore convergence properties of our solutions. The impact of the
97 use of adaptivity in Gerris will be more completely explored in a companion
98 paper examining the lock-release experiment (O’Callaghan et al, 2009, pers
99 comm).

100 For reference, a “standard run” will use constant viscosity and diffusivity
101 values of $1.0 \times 10^{-6} \text{ m}^2\text{s}^{-1}$, and will not use adaptivity. Spatially, most of the
102 domain will be covered with a level of resolution of 7, i.e., the grid spacing

103 (the same in the x and z directions) will be “H” the depth of the fluid (see
104 Figure 1) divided by 2^7 , so that in this case with $H = 0.15$ m, the grid spacing
105 is 1.17×10^{-3} m. At this level of resolution, Gerris has grid spacing comparable
106 to that used by Berntsen et al (2006) and Bourgault and Kelley (2007). In
107 anticipation of boundary layers along the slope, the semi-structured Gerris grid
108 is exploited to give a level of resolution of 9 there. This spatial distribution is
109 fixed in time for the standard runs.

110 The timestep in Gerris is dynamically adjusted in order to verify the CFL con-
111 dition to satisfy advection scheme stability. A maximum timestep of 1.5×10^{-3} s
112 is used, and for all but the runs with the finest grids suffices. For example, for
113 the adaptive runs described later that allow maximum levels of resolution of
114 10, 11, and 12, the timestep drops to around 80, 60, and 40 per cent, respec-
115 tively, relative to the maximum timestep, generally over the last 30 per cent
116 of the test run time reflecting the increase of activity during wave breaking
117 allied to on-going grid refinement.

118 Gerris maintains second order accuracy for spatial operators by a consistent
119 grid mapping from the high resolution grid along the slope to the relatively
120 coarser grid covering most of the domain (see Popinet, 2003 for details). An
121 example of how the grid is laid out next to the sloping boundary is illustrated
122 in Fig. 2. Note that the lower boundary in Fig. 2 is that given by the line
123 showing the slope. Gerris uses a “cut-cell” technique to determine the best
124 boundary fit within a cell, and boundary fluxes are calculated normal to this
125 boundary (see A.3).

126 *Insert Figure 2 here*

127 The standard model test runs are initialised using the parameters describing
128 model experiment (d) in Table 1, in particular having a slope of 0.217, and an
129 initial pycnocline depth of $z_i = 0.024$ m below the upper rigid lid of the model.

130 *2.2 Model test : transport coefficient variation*

131 Confidence in our standard model set-up was obtained from a convergence
132 test where the initial grid resolution is the same, but the viscosity and diffu-
133 sivity coefficients are changed. Here, the diffusivity and viscosity coefficients
134 are set equal to one another, giving a Prandtl number (the ratio of viscos-
135 ity to diffusivity) of 1 for the present set of experiments. This will go some
136 way to demonstrating that the implicit viscous and diffusive effects from the
137 numerical discretisation are not dominating the overall model solution at the
138 transport values used in the majority of the runs reported.

139 Figure 3 shows density contours at time 7.5 s into each run for different values

140 of the diffusivity and viscosity coefficients. As the coefficients are reduced from
141 Fig. 3(a) to (d) it is apparent that the model solution at this time is different in
142 each case. In Fig. 3(a) the relatively large coefficients overly diffuse the density
143 profile over the time of the ISW propagation. Figure 3(b) is the reference case,
144 showing contours comparable to Bourgault and Kelley (2004) (see their Figure
145 10), with lighter fluid being drawn down towards the slope as the wave breaks.
146 Upstream, downslope flow has compressed the pycnocline onto the slope itself;
147 this downstream flow then separates where it meets the upslope flow of denser
148 water, resulting in the circulation driving the lighter fluid down toward the
149 slope.

150 *Insert Figure 3 here*

151 A further reduction in the diffusivity and viscosity coefficients results in Fig.
152 3(c). The first thing to note is that the pycnocline to the left of the breaking
153 wave is tighter than that in Fig. 3(b); even in our standard case there has been
154 some diffusion acting to spread the initial profile. The upstream pycnocline
155 is also tighter and further down the slope than Fig. 3(b), suggesting that the
156 downslope flow has been relatively intensified. It is also clear that the top of
157 the breaking wave is now able to overshoot, forming a loop of lighter material
158 ahead of the upslope flow of dense material. As a result, the lighter fluid being
159 drawn down behind the wave appears more restricted.

160 The final reduction in the diffusivity and viscosity coefficients gives the con-
161 tours in Fig. 3(d); the upstream downslope flow now appears even greater,
162 such that the upstream pycnocline extends even further down the slope. It
163 would seem that the overshoot of lighter fluid is being drawn by this down
164 slope flow under the wave in such a way that instead of the upslope flow of
165 denser fluid recirculating clockwise, it is now forced up and around counter-
166 clockwise instead. The overall change in the solution from Fig. 3(c) to (d)
167 shows that the model is still responding to changes in the coefficients, rather
168 than being dominated by the numerical truncation errors.

169 *2.3 Model test : impact of adaptivity*

170 Using adaptivity, solution convergence for a specific case of a model initialised
171 as the standard run can be explored. Now each of the model initial condi-
172 tions are the same, but the maximum allowable level of resolution is changed
173 for each run. This strategy assesses solution dependence on the grid resolu-
174 tion. Adaptivity is based on resolution of selected spatial scales, e.g., vorticity
175 norms, tracer gradients, as quantified by equations (A.13) and (A.14), respec-
176 tively. As a run proceeds, these spatial scales are diagnosed, and if deemed
177 to be under-resolved, a grid refinement then operates until either the spatial

178 scales are resolved or the maximum allowable resolution has been reached. The
179 scheme also allows for coarsening so as not to waste resources as gradients relax
180 (except along solid boundaries where resolved scales must not change). The
181 refinement preserves the space and time second order accuracy of the model.
182 The parameters determining this time-adaptive behaviour then become extra
183 model convergence parameters, in this case the maximum allowable resolution
184 and the parameter ϵ in the adaptivity criteria, where equations A.13 and A.14
185 define ϵ in section A.4 in the Appendix. For the majority of adaptive runs, a
186 single value of $\epsilon = 5.0 \times 10^{-2}$ is used, and the adaptive criteria are here applied
187 to the density and vorticity. In cases of multiple adaptative criteria, cells are
188 refined whenever they violate either of the refinement criteria, and coarsened
189 whenever all the coarsening criteria are met.

190 An example is shown in Fig. 4. Standard run density contours at time 7.5 s
191 into the run are shown in Fig. 4(a). An adaptive run that is initialised exactly
192 as for the standard run, but is allowed to adapt up to a maximum level of
193 resolution of 12 (based on the local density gradient and/or the vorticity), is
194 shown at the same time in Fig. 4(b). The difference between these frames is
195 contoured in Fig. 4(c). By comparing Figs. 4(a) and (b), it is apparent that
196 the adaptive run results in some different features, notably the tightening of
197 the contours for the downslope flow as it is forced to rotate around the denser
198 fluid, the extended counter-clockwise roll-up of lighter fluid, and the sharper
199 finger to its right. Figure 4(c) contours the density differences; these differences
200 range from -16 to 10 kgm^{-3} relative to the constant background density of
201 1000 kgm^{-3} , so there are percentage changes of around 1% or so. Since the
202 majority of contours between Figs. 4(a) and (b) are similar, it would seem
203 that most of these changes represent a shift in position of features, rather
204 than gross amplitude errors. Regardless, it is clear that the standard run is
205 different when adaptivity in time is used.

206 *Insert Figure 4 here*

207 To illustrate the relationship between the adaptivity and the dynamics, Fig. 5
208 contours the resolution levels underlying the solution in Fig. 4(b). The range
209 of levels chosen for this solution range from 7 (the coarsest) to 12 (the finest).
210 The dynamically evolving resolution is determined by the refinement criteria,
211 and the maximum allowed level of resolution. For this instance, these criteria
212 combine to cover the wave breaking region with levels 8 to 10, with most of the
213 domain remaining at the original value of 7. The level 10 regions are further
214 extended to cover the boundary layers along the slope to resolve the evolving
215 flows.

216 *Insert Figure 5 here*

217 To better quantify the convergence consider the above experiment run out to

218 7.5 s using adaptive runs that allow for maximum levels of refinement of 10, 11,
219 and 12. In these runs the initial grid is at level 7 nearly everywhere, except for
220 close to the solid boundary where the maximum level is set. At each timestep
221 the adaptive criteria are checked, and if violated grid refinement takes place.
222 The maximum differences in density and speed at time 7.5 s for the adap-
223 tive sequence for (10 – standard, 11 – 10, 12 – 11) were (16.6, 3.5, 2.5) kgm^{-3}
224 and (4.8, 1.06, 0.6) cms^{-1} , respectively. The runs were still converging as the
225 maximum level of resolution was increased, but there has been a relatively
226 significant change between refinement levels 10 and 11.

227 Adaptivity is only useful if it proves to be more efficient than the equivalent
228 non-adaptive run initialised everywhere with the finest resolution obtained
229 in the adaptive run, and if the adaptive and constant resolution solutions
230 converge. To that end constant resolution versions have been run as above
231 to time 7.5 s using initial uniform levels of refinement of 5 to 10. For these
232 two dimensional runs, the total cpu memory increases by 4 for each increase
233 in level, here 1 Mb for level 5 up to 1002 Mb for level 10. For the single cpu
234 workstations used in this study, levels 11 and 12 at regular resolution exceeded
235 the resources, and could not be run. However, cpu timings showed that for
236 each level change, the cpu increases by around 5, going from 0.007 days for
237 level 5 to 10.3 days for level 10, so that levels 11 and 12 would require at least
238 50 and 250 days, respectively, to get to time 7.5 s.

239 In comparison, the adaptive run with maximum level of 10 requires 0.79 days
240 to reach time 7.5 s, and uses a maximum of 45 Mb of memory. For refinements
241 up to 11 and 12, the cpu times and maximum memories are 2.2 and 4.9 days,
242 and 57 and 81 Mb, respectively. For each maximum level change, the cpu
243 time increases by between 2 and 3, not only due to memory increases but also
244 because the timestep starts to decline to satisfy the advective CFL condition
245 for the finest resolution. In comparison to its constant resolution counterpart
246 (recalling the values for 11 and 12 are conservative estimates), the adaptive
247 run uses factors of 22, 70, 198 and 13, 23, 50 less for memory and cpu time,
248 respectively, for levels 10, 11, and 12. In terms of total numbers of grid cells,
249 the adaptive runs use maximums of 116974, 145203, and 197613 for levels
250 10, 11, and 12, respectively, factors of 23, 76, and 222 times less than the
251 respective constant resolution runs, reflecting the memory changes.

252 So, if the adaptive run at a given level is accessing all the scales of its constant
253 resolution counterpart, then it's clear that the adaptivity will provide great
254 cpu time efficiency, here increasing up to a factor of 50. These gains are case
255 dependent, and will increase as the volume of fine scales reduces compared
256 to the domain volume. As Fig. 5 shows, the high resolution region is mainly
257 confined to the wave breaking zone.

258 Without an analytic solution, model consistency is checked using convergence.

259 The maximum density and speed differences for (6 – 5) down to (10 – 9) for
 260 the constant resolution runs were
 261 (34.0, 28.0, 20.0, 16.0, 8.0) kgm^{-3} and (14.0, 11.0, 8.0, 3.7, 3.2) cms^{-1}
 262 for density and speed, respectively. As with the adaptive sequence above, con-
 263 vergence is clear. Finally, taking the level 10 constant resolution solution as
 264 a reference, the differences between it and the standard run and the level 10,
 265 11, and 12 adaptive runs are
 266 (15.0, 5.0, 4.0, 4.0) kgm^{-3} and (4.7, 1.05, 1.05, 1.5) cms^{-1}
 267 for density and speed, respectively. Again, convergence is clear, but some sat-
 268 uration as the adaptive models are accessing some finer scales.

269 Could we have started with a relatively low level of resolution and then allowed
 270 adaptivity to fill in evolving scales as required? In general no, as the initial
 271 conditions and the boundaries need to be adequately resolved at the outset;
 272 adaptivity cannot in general compensate for initially unresolved scales implied
 273 by the boundaries or initial stratification. For a uniform medium at rest with
 274 regular boundaries, this strategy works well (see Popinet (2006) for examples),
 275 and maximises the adaptive gain. In these ISW simulations, under resolution
 276 of the initial stratification will result in cumulative errors later in time. The
 277 resolution of the standard run is perhaps a compromise between adequately
 278 capturing the initial scales, and spanning the parameter space in reasonable
 279 time.

280 In summary, these model tests show that;

- 281 (1) the implicit viscosity and diffusivity of the numerical discretisation is
 282 not dominating the overall solution for values of $1 \times 10^{-6} \text{m}^2\text{s}^{-1}$ for the
 283 viscosity and diffusivity for the standard run;
- 284 (2) differences of around 1 per cent remain in the density as a result of under
 285 resolution when not using the adaptivity in time for the standard run;
- 286 (3) adaptivity can provide factors of up to 50 times saving in cpu time relative
 287 to the equivalent constant resolution run at the maximum resolution of
 288 the adaptive run. This scaling arises here because the wave breaking
 289 volume is comparatively compact, and the efficiency of the adaptive grid
 290 scheme in Gerris.

291 To explore a wider parameter space, model results using the standard run
 292 configuration are compiled and discussed. To provide comparison with the
 293 Helfrich (1992) and Michallet and Ivey (1999) observations, and the numerical
 294 results of Bourgault and Kelley (2007), slopes as shallow as 0.034 relative to
 295 the standard run's of 0.217 will be simulated. The shallowest slope requires
 296 a domain 5 times larger and needs to run for at least 5 times as long as the
 297 standard run in order to capture the wave breaking. From a resource point,
 298 adaptive runs may have been feasible, but given that the percentage differences
 299 might be around 1 per cent, and that the wider context is testing the Gerris

300 dynamical core, the standard run configuration will be presented. As we shall
301 see, experimentally observed turbulence at the time of wave breaking does not
302 occur in the simulations, and so there is clear scope for future adaptive runs
303 to capture finer scales and the third dimension.

304 **3 Model Results**

305 In this section, model results from the experiments listed in Tables 1 and 2
306 are described. The intention is to compare Gerris to the laboratory experi-
307 ments of Helfrich (1992) and Michallet and Ivey (1999). Comparisons with
308 the laterally-averaged non-hydrostatic model of Bourgault and Kelley (2007)
309 (as described in Bourgault and Kelley (2004)) are also made. Each run in this
310 section is initialised as per the standard run in terms of grid resolution, with
311 no adaptivity, and with diffusivity equal to viscosity of $1.0 \times 10^{-6} \text{ m}^2\text{s}^{-1}$.

312 The phenomena of interest are the wave breaking process and subsequent
313 turbulent vortex (“bolus”) generation, bolus propagation, and the energetics
314 resulting from the wave breaking, in particular what proportion of the incom-
315 ing energy flux is reflected (and hence how much is left for mixing processes
316 up-slope).

317 *3.1 Wave breaking turbulence*

318 In the Michallet and Ivey (1999) experiments they identify instability associ-
319 ated with three-dimensional motion. This instability and subsequent turbu-
320 lence is apparent in the sequence of frames in their Figure 3, from the time that
321 the initial wave breaks until later as the bolus runs upslope. Helfrich (1992)
322 similarly identifies an initial patch of wave instability (or “break point”) from
323 shadowgraphs, and consequently defines the position of this break point to be
324 the “maximum offshore location of the initial patch of turbulence”.

325 Gerris does not produce such instability or turbulence as the initial wave
326 breaking takes place, in common with Bourgault and Kelley (2004). Even as
327 the model resolution and viscosity and diffusivity are varied (see Figs. 3 and 4
328 for example), the pycnocline to the left of the breaking wave remains relatively
329 coherent, with none of the clear filamentary structure seen in Michallet and
330 Ivey (1999). The most likely explanation – as proffered by Bourgault and
331 Kelley (2004) – is that the two dimensional models are missing important
332 three-dimensional processes.

333 This is not to imply that the model pycnocline is not “dynamic”. Indeed, as the

334 slope is reduced and the number of boluses increases, a complex structure of
335 vortices and density develops from which each bolus emerges (not shown). As
336 the overturning and wave breaking processes diminish so does the pycnocline
337 complexity, slowly returning toward a stable, final structure.

338 We identify a model break point by comparison with Figures 3c and 4a in
339 Michallet and Ivey (1999), and their observation that “the first sign of breaking
340 seems to be a gravitational instability, following the separation of the flow in
341 the lower layer”. Diagnosis of model flow vectors and vorticity allied to density
342 contours shows when the lower layer flow first separates from the slope, leading
343 to the formation of a clear counter-clockwise circulation beneath the wave; this
344 we identify as our break point. Beyond this point, the counter-clockwise vortex
345 intensifies and enlarges, such that at later times a bolus is formed; this follows
346 the sequence of Figures 3c to 3e and 4a to 4c in Michallet and Ivey (1999).

347 *3.2 Bolus Identification*

348 Using model experiment 2 in Table 1 as an example, Figure 6 shows a snapshot
349 at time 37.5 seconds into the run. In Fig. 6(a) for density contours there
350 are three distinct and discrete features with core densities labelled as 1016.0
351 and 1028.0 kgm^{-3} above that of the surrounding material. Following Helfrich
352 (1992), each of these counts as a bolus since they exist beyond the undisturbed
353 pycnocline-slope intersection (indicated by the horizontal line in the model
354 domain in each frame). Note that the vertical scale is stretched four times
355 relative to the horizontal for clarity.

356 *Insert Figure 6 here*

357 Figure 6(b) shows horizontal flow, with positive (up-slope flow) contours within
358 each bolus (with peak values of 4.0 and 5.0 cms^{-1}), and negative (down-slope
359 return flow) contours extending from just above each bolus to the model do-
360 main rigid lid at the top (indicated by the 2.0 cms^{-1} contour). This shows that
361 these density anomalies are not stationary. Lastly, Fig. 6(c) contours vorticity,
362 showing discrete structures for each bolus comprising a positive vorticity “cap”
363 indicating local counter-clockwise circulation (labelled with the 1.34 s^{-1} con-
364 tours) overlying negative vorticity locally clockwise circulation (the -3.34s^{-1}
365 contours).

366 However, the Helfrich (1992) experiments showed that boluses are generated
367 below the undisturbed pycnocline-slope intersection as a result of the ISW
368 breaking process. In Fig. 6 signatures of a fourth bolus are apparent within
369 the bound of the pycnocline-slope intersection; there is discrete density (but
370 not as obvious as those further up the slope indicated by the 1032 kgm^{-3}
371 contour), there is upslope flow of around 3.0 cms^{-1} with return downslope flow

372 above, and a consequent positive vorticity cap with less clear negative vorticity
373 below. This is typical of the model bolus structure below the pycnocline-slope
374 intersection – and particularly so for the emergence of subsequent boluses after
375 the first one – in that the bolus signatures tend to be less distinct.

376 Nevertheless, by identifying each new bolus in terms of its density, upslope
377 flow, and vorticity, it is possible to build up a picture of their history from close
378 to initial wave breaking until they are well up the slope. An example of such a
379 time history is plotted in Fig. 7 for model experiment 2 showing the evolution
380 of four boluses moving upslope, the first identified with crosses, the second
381 squares, the third and fourth triangles and diamonds, respectively. Each bolus
382 trajectory is plotted in terms of its position relative to the pycnocline-slope
383 intersection ($x/X_{BP} = 0$) as a function of time. The character of these trajec-
384 tories compare well with those described and plotted by Helfrich (1992) for his
385 Figure 8, in particular the fact that each bolus is generated for $x/X_{BP} < 0$ (the
386 horizontal dashed line), that subsequent boluses first appear further up the
387 slope than their predecessors, and that boluses can be overtaken and absorbed
388 by boluses following on from behind.

389 *Insert Figure 7 here*

390 In summary, bolus identification in these two dimensional model runs can be
391 done using density (relative to local background values), zonal velocity, and/or
392 vorticity signatures. Bolus identification below the undisturbed pycnocline-
393 slope intersection is undoubtedly messy, especially for any subsequent boluses,
394 but by tracking backwards from where they emerge identification can be made.
395 These techniques have been used to compile the bolus statistics for the model
396 experiments in this paper.

397 *3.3 First Bolus Evolution*

398 Typical evolution of the first bolus from close to its emergence until propaga-
399 tion well upslope is illustrated in Figs. 8 and 9, again for model experiment 2
400 in Table 1. Figure 8 shows contours of density, while Figure 9 combines con-
401 tour lines of vorticity with velocity vectors (the latter at a relatively coarser
402 level of resolution of 6 for clarity) to show the circulation. In each figure the
403 frames (a), (b), (c), and (d) are at times 22.5, 27.0, 30.0, and 37.5 seconds
404 into the run, respectively. The size of each frame is proportional to the height
405 of the bolus at that time (with the bolus heights detailed in the Fig. 8 cap-
406 tion for reference). Frames (a) and (b) are for bolus positions downslope of
407 the undisturbed pycnocline-slope intersection, while frames (c) and (d) are
408 upslope.

409 *Insert Figure 8 here Insert Figure 9 here*

410 The initial model bolus tends to have three elements clearly delineated in
411 the density and flow fields. This overall structure is contained by the strong
412 downslope flow ahead of the bolus that separates at its front, then passes
413 over the top of the bolus, with re-circulation at the back of the bolus. The
414 three bolus elements comprise two counter-clockwise rotating cells (at the
415 back and front), with a clockwise rotating cell between them. Note that the
416 velocity vectors have been thinned for clarity. However, the vorticity contours
417 are based on the full resolution, and the tightening of contours close to the
418 slope show the presence of boundary layers.

419 Dense upslope flowing fluid is drawn into the back of the bolus, and entrains
420 with lighter fluid being circulated around the left-most vortex. This fluid then
421 circulates and mixes within the core of the bolus. Note that this mixing process
422 continues to dilute the density within the bolus as it propagates upslope, such
423 that the maximum density in frame (a) of 1047.0 kgm^{-3} steadily reduces to
424 1017.0 kgm^{-3} by frame (d) in Fig. 8.

425 A characteristic bolus height and base length can be obtained from the evolu-
426 ting bolus structure. The height is the maximum distance from the slope up to
427 where the down slope flow vectors intersect the density contours at the bolus
428 top, locating the transition between the core bolus and background densities.
429 As this density difference reduces as the bolus propagates upslope, the transi-
430 tion sharpness declines, but the bolus top is still indentifiable via flow vectors.
431 Similarly, bolus base length can be defined in terms of the distance between
432 the upward flow at the bolus leading nose to downward flow at the bolus rear
433 edge. Again, these locations can be correlated with density gradients to iden-
434 tify the bounds of a single bolus. The solid lines on frames (b) in Figs. 8 and 9
435 illustrate these definitions. It is clear that the overall dimensions of the bolus
436 change, with general shrinkage in both height (going from 0.03 m in frame (a)
437 to 0.0144 m by frame (d)) and base length (from 0.05 m in (a) to 0.03 m in
438 (d)) as the bolus progresses upslope.

439 It is also clear that the bolus three cell structure changes as it moves upslope.
440 It would seem that the cell at the front of the bolus shrinks (most evidently in
441 density), and that the left-most vortex seems to extend over the middle vortex
442 such that at the later times the typical cap structure in vorticity is obtained.
443 This is perhaps in response to the change in flow field. Note that in frames (a)
444 and (b) in Fig. 9 the velocity vectors show that there is downslope flow into
445 the nose of the bolus. However, in frames (c) and (d), where the bolus is now
446 moving beyond the undisturbed pycnocline-slope intersection, this downslope
447 flow disappears to be replaced by upslope flow. The bolus structure at these
448 later times is consistent with that seen in other models (e.g. Härtel et al (2000)
449 and Venayagamoorthy and Fringer (2007)), and similar to gravity current head
450 structures described by Simpson (1972, 1997).

The bolus properties examined by Helfrich (1992) in his experiments for a parameter space dependent on the initial densities, pycnocline depths, and slope angle, can be diagnosed from Gerris to provide for a more quantitative evaluation of the model. While particular experiments of Helfrich (1992) are not modelled directly, the observational space in terms of the parameter λ will be explored, where

$$\lambda = (kL)^{-1}, \quad k^{-1} = \sqrt{\frac{4(d_+d_-)^2}{3(d_+ - d_-)a_0}}, \quad (6)$$

452 where L , d_+ , and d_- are defined in Fig. 1, and a_0 is the maximum displacement
 453 of the incoming wave. All of the model experiments in Tables 1 and 2 will be
 454 used and plotted against their reference label, i.e., 1-4 and a-i. Note that
 455 experiments 1-4 and a-d are parallel in every regard except the initial depth
 456 of the pycnocline; this then changes the respective value of λ .

457 Figure 10 plots breaking location in terms of a_0/d_{BP} as a function of λ for
 458 comparison with Helfrich’s (1992) Figure 6. Both show a tendency for an
 459 increase of a_0/d_{BP} as λ decreases. For the larger range of λ used here, the
 460 model suggests that the breaking location actually saturates as λ increases.
 461 The model values for a_0/d_{BP} are typically 0.2 or so higher than those found
 462 in the experiments. As described earlier, identifying the break point in the
 463 model is difficult due to the lack of an initial patch of instability seen in the
 464 experiments.

465 *Insert Figure 10 here*

466 The number of boluses in each experiment as a function of λ is shown in Fig.
 467 11 for comparison with Helfrich’s (1992) Figure 9. The model captures the
 468 dependence with λ well, showing a typical increase in the number of boluses
 469 as λ decreases. Furthermore, the multiple-bolus characteristics shown in Fig.
 470 7 fit that seen and discussed by Helfrich (1992) with respect to his Figure 8.
 471 Note that the model results do not suggest an absolute scaling with respect
 472 to λ . Rather, for each sequence of “similar” experiments, i.e., 1-4, a-d, e-i, the
 473 scaling with λ indeed holds, but the number of boluses for a given λ can vary.

474 *Insert Figure 11 here*

475 The initial height of the first bolus in Fig. 12 compares favourably with Hel-
 476 frich’s (1992) result in his Figure 10, both covering the range 1 to 2 over the
 477 values of λ sampled. The agreement is relatively good given the uncertainties
 478 in estimating the time and then the actual first bolus height (see the definitions
 479 and error estimates quoted by Helfrich).

480 *Insert Figure 12 here*

481 Frames (a)-(c) in Fig. 13 show the first bolus aspect ratios (H/l_b) as a function
482 of distance for the model experiments for comparison with Figure 11 in Helfrich
483 (1992). The major consistent difference across the models is their tendency to
484 have the aspect ratio somewhat larger than observed; Helfrich shows values
485 in the range 0.2 to 0.4 (given his estimated uncertainties), whereas the model
486 aspect ratios are typically in the range 0.4 to 0.8. Helfrich also notes a tendency
487 for the aspect ratio to increase with distance; this general tendency is not so
488 apparent in the model, but there are certainly individual instances where this
489 does occur.

490 *Insert Figure 13 here*

491 The decay of the first bolus height with distance is shown in Fig. 13(d)-(f) for
492 comparison with Helfrich's (1992) Figure 12. The near linear decay observed
493 by Helfrich is reproduced by nearly all of the model experiments. In some of
494 the model experiments (particularly in Fig. 13(f)) the bolus height is seen to
495 increase at early times in the bolus evolution; again uncertainties in timing of
496 measurements between the observations and models may contribute to these
497 differences.

498 3.5 *Energy Reflectance*

499 As a final consideration, comparisons with energy reflectance results from
500 Bourgault and Kelley (2007) are made, specifically their free slip sidewall re-
501 sults shown in their Figure 6. Bourgault and Kelley (2007) covered all of the
502 Michallet and Ivey (1999) experiments in compiling their results. In this study
503 we have focussed on specific experiments labelled e-i in Table 2 corresponding
504 to experiments 4, 8, 12, 7, and 13, respectively, from Table 1 in Michallet and
505 Ivey (1999); results from the latter are reproduced in Table 3. The Gerris wave
506 amplitudes (a_0) in Table 2 match fairly well, although they tend to typically be
507 a few percent less than measured. The comparison for the characteristic length
508 L_w shows that the model responded a little more erratically, with slight over-
509 estimates for shorter L_w but with relatively larger underestimates for longer
510 L_w (experiments h and i).

For direct comparison with the model results of Bourgault and Kelley (2007),
the energy reflectance "R" was diagnosed, where

$$R = E_R/E_0, \quad (7)$$

where E_0 and E_R (as defined by equations 7 and 8 in Bourgault and Kelley
(2007)) are the energy fluxes measured at the base of the slope for the initial

incoming and first reflected waves, respectively. The reflectance provides an important measure of the likely amount of mixing induced by the breaking of these waves, and scaling their behaviour for parameterisation in larger and climate scale models remains relevant. To validate their model, Bourgault and Kelley (2007) compared the dependence of their model R in terms of the Iribarren number (Iribarren and Nogales (1949) ξ where,

$$\xi = s/\sqrt{(a_0/L_w)}, \quad (8)$$

where s is the slope, for the Michallet and Ivey (1999) experiments. Bourgault and Kelley (2007) found their free slip sidewall model R values are typically 0.1 larger than the equivalent experimental values. They showed that by including no slip sidewalls close agreement with the laboratory experiments could be obtained. In terms of the free slip sidewall runs, Bourgault and Kelley (2007) performed a curve fit to their results and obtained a parameterisation of the form,

$$R = 1 - e^{-\xi/\xi_0}, \quad (9)$$

511 where a least squares fit returns $\xi_0 = 0.78 \pm 0.02$.

512 The results from the Gerris experiments are summarised in Figure 14 showing
513 R as a function of ξ .

514 *Insert Figure 14 here*

515 The Gerris results for R show that experiments e, f, g, and h have reflectance
516 estimates close to those of Bourgault and Kelley (2007) (the bold curve), and
517 with a similar dependence on ξ . The only anomaly is experiment i, which falls
518 closer to the Michallet and Ivey (1999) R value.

519 For comparison, Fig. 15 plots the individual energy fluxes as a function of time
520 used to calculate the reflectances for model experiments e to i. The bold curve
521 for experiment f in Fig. 15(b) compares favourably with that from Figure 3 in
522 Bourgault and Kelley (2007), and indeed the value obtained for R is close to
523 that found in their model. Note that the character of each energy flux curve
524 changes with slope, the density jump $\Delta\rho$, and the depth of the pycnocline z_i ,
525 so that the incoming energy flux and first return pulse can be relatively close
526 or widely separated in time from each other.

527 *Insert Figure 15 here*

528 It is encouraging that the tendency for increasing R with ξ is reproduced by
529 Gerris and generally in close agreement with Bourgault and Kelley (2007)
530 model results. The only outlier is experiment i. In terms of differences, it
531 is clear that the time history of energy flux for experiment i has quite a
532 narrow time separation between the incoming and first return pulse relative
533 to the other experiments. Experiment i also has a significantly larger value of

534 λ (equation 6) than all the other experiments (see Tables 1 and 2). It is clear,
535 however, that further runs will be needed to cover the full range of Michallet
536 and Ivey (1999) experiments in order to assess and understand how anomalous
537 the experiment i reflectance result is.

538 4 Conclusion

539 Multi-scale, non-hydrostatic simulations of geophysical flows represent a sig-
540 nificant computational challenge. In this paper the potential of an adaptive (in
541 space *and* time) model, Gerris, is explored, in terms of validation against lab-
542 oratory scale experiments, and against other models benchmarked in a similar
543 fashion. Gerris combines a tree-based structure with a finite-volume discretisa-
544 tion for efficient adaptivity, thereby allowing for local refinement over fine scale
545 features without the need for excessive refinement over less dynamic parts of
546 the domain. The ability of Gerris to handle largely horizontal geophysical pro-
547 cesses was demonstrated in Popinet and Rickard (2007). This paper extends
548 that work by looking in more detail at vertical processes.

549 The flexible grid structure of Gerris allows for selective refinement in the model
550 domain. Here this property is exploited to allow for increased refinement along
551 the sloping boundary to better resolve evolving boundary layers. For most of
552 the runs in this paper this spatially non-uniform grid is fixed in time (for
553 our so-called “standard runs”) in order to be able to span the parameter
554 space of interest, and to allow comparison with previously published model
555 output. Similarly, the diffusivity and viscosity coefficients have been restricted
556 for comparison purposes. All the runs in this paper were done on single CPU
557 workstations, but note that Gerris is fully parallelised.

558 For the adaptive runs, efficiency can be measured by comparison with a version
559 comprising constant resolution equal to the finest resolution of the adaptive
560 run. By this measure the adaptive run requires some 10 to 50 times less cpu
561 time, and up to 22 to 200 times less memory (dependent on maximum allowed
562 resolution) than the constant resolution run for the breaking waves. This gain
563 is clearly problem dependent, as it will be proportional to the volume fraction
564 in which the finest scales arise.

565 The general dynamical features of internal solitary waves breaking on uniform
566 slopes reported by Helfrich (1992) and Michallet and Ivey (1999) are repro-
567 duced by Gerris, especially given the experimental uncertainties, and the fact
568 that the model simulations are two-dimensional and use a rigid lid rather than
569 a free surface as a top boundary condition. The absence of turbulent genera-
570 tion at the time of wave breaking in the models has been attributed to the lack
571 of a third dimension (and so will require future simulations). Nevertheless, the

572 overall correspondence between the model and observations suggests that the
573 major energy conversion processes involved in wave breaking leading to bolus
574 generation can be largely captured in two dimensions. Some of the detailed
575 diagnostics show that the model gets the general time evolution correct, but
576 that amplitudes can be wrong (for instance, in terms of the bolus aspect ratio).

577 For the tests in this paper we have limited ourselves to two dimensions, and
578 so have not further explored the issues of side wall interactions considered by
579 Bourgault and Kelley (2007). The latter find that they need to introduce side
580 wall friction effects into their model in order to reproduce the experimentally
581 obtained energy reflectance values of Michallet and Ivey (1999). Furthermore,
582 Bourgault and Kelley (2007) find that the Helfrich (1992) reflectance values
583 are 0.1 to 0.4 smaller again than Michallet and Ivey (1999); the reasons for
584 this are unclear, but Bourgault and Kelley (2007) suggest that again side-
585 wall effects have an influence, as well as the different Helfrich (1992) tank
586 geometry. Given these uncertainties should we expect to be able to reproduce
587 the Helfrich (1992) bolus evolution results with our present numerical exper-
588 iments? Perhaps not, but the similarities between the model and experiment
589 suggest that perhaps the lateral effects are not dominating the wave breaking
590 process; nevertheless, more complete answers will have to wait for fully three
591 dimensional simulations.

592 Aspects of bolus evolution are revealed by the model. The boluses are gener-
593 ated below the undisturbed pycnocline-slope intersection, and while the bolus
594 is on this part of the slope, the model suggests a three cell structure to the
595 bolus in which denser up-slope flowing material is mixed into the bolus in-
596 terior with the lighter down-slope flowing fluid. As the bolus moves upslope
597 toward the undisturbed pycnocline-slope intersection and beyond it, the bolus
598 changes from three to two cells, eventually forming a structure similar to typ-
599 ical gravity current heads. This bolus evolution is consistent across the range
600 of model parameters explored.

601 In terms of Gerris as a geophysical tool, it is encouraging that Gerris performs
602 well in comparison to other non-hydrostatic geophysical models such as that of
603 Bourgault and Kelley (2004, 2007), and the Massachusetts Institute of Tech-
604 nology general circulation model (Marshall et al., 1997) and the Bergen Ocean
605 Model (Berntsen (2000)) which are both discussed in Berntsen et al (2006) in
606 terms of wave breaking tests. Adaptivity is presently enabled by collocation of
607 prognostic variables, making the Gerris dynamical core unusual with regard to
608 other geophysical models. The tests in this paper and previously (Popinet and
609 Rickard (2007)) continue to suggest that Gerris and its adaptivity represents
610 an efficient alternative to simulate multi-scale, non-hydrostatic flows.

611 With isotropic adaptivity, there will be no vertical stacked layers in general.
612 Unresolved processes such as vertical mixing, convection etc are parameterised

613 locally down each vertical column in many global scale models. The loss of
614 this vertical structure means parameterisation amendment will be required
615 in order to convert purely vertical schemes to more general forms. Further,
616 selection rules will be needed to separate when and where the adaptive model
617 is actually resolving or not these small scale processes. The challenge will be
618 to efficiently incorporate such parameterisations without endangering other
619 adaptivity gains (as discussed by Pain et al (2005) for unstructured models).

620 Whether adaptivity coupled with a pressure solver for non-hydrostatic flows
621 can maximise the available computational resources needs further study. A
622 stumbling block is likely to be the convergence properties of the pressure
623 solver in the presence of excessive grid aspect ratios, since typical geophysical
624 systems have horizontal scales much larger than in the vertical. This issue
625 has recently been discussed by Matsumura and Hasumi (2008) who suggest
626 that there are potential acceleration techniques that can make non-hydrostatic
627 multi-grid Poisson inversions competitive with their hydrostatic equivalents;
628 this provides further encouragement as a multi-grid pressure solver is integral
629 to Gerris.

630 In this paper, density is treated as the only independent tracer. Future tests
631 with Gerris will need to examine more closely an oceanic equation of state
632 linking potential temperature and salinity tracers to the in-situ density. Fur-
633 thermore, as the model is applied to larger geophysical systems, the potential
634 for inaccuracies in the discretisation of the horizontal hydrostatic pressure
635 gradient (especially across a grid that is adapting in the vertical) may exist
636 and will need to be quantified. In the present laboratory scale experiments
637 the influence of such errors is small; maintaining accuracy will become more
638 critical for larger systems.

639 **Acknowledgements**

640 This work was funded by the Foundation for Research, Science, and Technol-
641 ogy, New Zealand, contract C01X0701. We are also grateful to two anony-
642 mous referees for their constructive critique leading to a greatly improved
643 manuscript.

645 **A Numerical discretisation of adaptive model**

646 The details of the numerical scheme are described in Popinet (2003) and we
 647 will only give a summary of the overall procedure.

648 *A.1 Temporal discretisation*

A staggered in time discretisation of the density and pressure leads to the following formally second-order accurate time discretisation of the momentum, continuity, and density equations (1), (2) and (3), respectively,

$$\frac{\mathbf{U}_{n+1} - \mathbf{U}_n}{\Delta t} + \mathbf{U}_{n+\frac{1}{2}} \cdot \nabla \mathbf{U}_{n+\frac{1}{2}} = -\frac{1}{\rho_0} \nabla p_{n+\frac{1}{2}} - \frac{\rho'_{n+\frac{1}{2}}}{\rho_0} \mathbf{g} + \frac{\nu}{2} \nabla^2 (\mathbf{U}_n + \mathbf{U}_{n+1}), \quad (\text{A.1})$$

$$\frac{\rho'_{n+\frac{1}{2}} - \rho'_{n-\frac{1}{2}}}{\Delta t} + \nabla \cdot (\rho'_n \mathbf{U}_n) = 0, \quad (\text{A.2})$$

$$\nabla \cdot \mathbf{U}_n = 0. \quad (\text{A.3})$$

This system is further simplified using a classical time-splitting projection method (Chorin, 1968) to give,

$$\frac{\mathbf{U}_\star - \mathbf{U}_n}{\Delta t} + \mathbf{U}_{n+\frac{1}{2}} \cdot \nabla \mathbf{U}_{n+\frac{1}{2}} = -\frac{\rho'_{n+\frac{1}{2}}}{\rho_0} \mathbf{g} + \frac{\nu}{2} \nabla^2 (\mathbf{U}_n + \mathbf{U}_\star), \quad (\text{A.4})$$

$$\frac{\rho'_{n+\frac{1}{2}} - \rho'_{n-\frac{1}{2}}}{\Delta t} + \nabla \cdot (\rho'_n \mathbf{U}_n) = 0, \quad (\text{A.5})$$

$$\mathbf{U}_{n+1} = \mathbf{U}_\star - \frac{\Delta t}{\rho_0} \nabla p_{n+\frac{1}{2}}, \quad (\text{A.6})$$

$$\nabla \cdot \mathbf{U}_{n+1} = 0, \quad (\text{A.7})$$

which requires the solution of the Poisson equation

$$\nabla \cdot \left[\frac{\Delta t}{\rho_0} \nabla p_{n+\frac{1}{2}} \right] = \nabla \cdot \mathbf{U}_\star \quad (\text{A.8})$$

649 This equation is solved efficiently using the quad/octree-based multilevel solver
 650 described in detail in Popinet (2003).

The discretised momentum equation (A.4) can be re-organised as

$$\frac{1}{\Delta t} \mathbf{U}_\star - \frac{\nu}{2} \nabla^2 \mathbf{U}_\star = \frac{\nu}{2} \nabla^2 \mathbf{U}_n - \frac{\rho'_{n+\frac{1}{2}}}{\rho_0} \mathbf{g} + \frac{1}{\Delta t} \mathbf{U}_n - \mathbf{U}_{n+\frac{1}{2}} \cdot \nabla \mathbf{U}_{n+\frac{1}{2}}, \quad (\text{A.9})$$

651 where the right-hand-side depends only on values at time n and $n + 1/2$. This
652 Helmholtz-type equation for \mathbf{U}_* can be solved efficiently using a variant of the
653 multilevel Poisson solver. The resulting Crank–Nicolson discretisation of the
654 viscous terms is formally second-order accurate and unconditionally stable.

655 The velocity advection term $\mathbf{U}_{n+\frac{1}{2}} \cdot \nabla \mathbf{U}_{n+\frac{1}{2}}$ and the density advection term
656 $\nabla \cdot (\rho'_n \mathbf{U}_n)$ are estimated using the Bell–Colella–Glaz second-order unsplit
657 upwind scheme (Bell et al 1989, Popinet 2003). This scheme is stable for CFL
658 numbers smaller than one.

659 *A.2 Spatial discretisation*

660 Space is discretised using a graded quadtree partitioning (octree in three di-
661 mensions). Second order accuracy is maintained in spatial operators, including
662 all boundaries. We refer the reader to Popinet (2003) and references therein
663 for a more detailed presentation of this data structure.

664 All the variables (components of the momentum, pressure and passive tracers)
665 are collocated at the centre of each square in 2D (resp. cubic in 3D) discreti-
666 sation volume. Consistent with a finite-volume formulation, the variables are
667 interpreted as the volume-averaged values for the corresponding discretisation
668 volume. The choice of a collocated definition of all variables makes momentum
669 conservation simpler when dealing with mesh adaptation (Popinet, 2003). It
670 is also a necessary choice in order to use the Godunov momentum advection
671 scheme of Bell, Colella and Glaz (Bell et al 1989), and it simplifies the imple-
672 mentation of the Crank–Nicolson discretisation of the viscous terms; however
673 one has to be careful to avoid the classic problem of decoupling of the pressure
674 and velocity field.

675 To do so, an approximate projection method (Almgren et al 2000, Popinet
676 2003) is used for the spatial discretisation of the pressure correction equa-
677 tion (A.6) and the associated divergence in the Poisson equation (A.8). In a
678 first step the auxiliary cell-centred velocity field \mathbf{U}_*^c is computed using equa-
679 tion (A.9). An auxiliary face-centred velocity field \mathbf{U}_*^f is then computed using
680 averaging of the cell-centred values on all the faces of the Cartesian discreti-
681 sation volumes. When faces are at the boundary between different levels of
682 refinement of the quad/octree mesh, averaging is performed so as to guar-
683 antee consistency of the corresponding volume fluxes (see Popinet (2003) for
684 details).

The divergence of the auxiliary velocity field appearing on the right-hand-side
of equation (A.8) is then computed for each control volume as the finite-volume

approximation

$$\nabla \cdot \mathbf{U}_* = \frac{1}{\Delta} \sum_f \mathbf{U}_*^f \cdot \mathbf{n}^f, \quad (\text{A.10})$$

685 with \mathbf{n}^f the unit normal vector to the face and Δ the length scale of the
686 control volume.

After solving equation (A.8), the pressure correction is applied to the face-centred auxiliary field

$$\mathbf{U}_{n+1}^f = \mathbf{U}_*^f - \frac{\Delta t}{\rho_0} \nabla^f p_{n+\frac{1}{2}}, \quad (\text{A.11})$$

687 where ∇^f is a simple face-centred gradient operator (consistent at coarse/fine
688 volume boundaries, see section 4.1 of Popinet 2003). The resulting face-centred
689 velocity field \mathbf{U}_{n+1}^f is exactly non-divergent by construction. This velocity field
690 is used to compute the momentum and density advection terms $\mathbf{U}_{n+\frac{1}{2}} \cdot \nabla \mathbf{U}_{n+\frac{1}{2}}$
691 and $\nabla \cdot (\rho'_n \mathbf{U}_n)$ so that the resulting scheme conserves mass and momentum
692 exactly.

The cell-centred velocity field at time $n + 1$ is obtained by applying a cell-centred pressure correction

$$\mathbf{U}_{n+1}^c = \mathbf{U}_*^c - \left| \frac{\Delta t}{\rho_0} \nabla^f p_{n+\frac{1}{2}} \right|^c, \quad (\text{A.12})$$

693 where the $\|\cdot\|^c$ operator denotes averaging over all the faces delimiting the con-
694 trol volume. The resulting cell-centred velocity field \mathbf{U}_{n+1}^c is approximately
695 divergence-free.

696 A.3 Representation of solid boundaries

697 Solid boundaries are represented using the *Cartesian cut-cell* scheme described
698 in Popinet (2003). This scheme uses surface- and volume- fluid fractions to ob-
699 tain a spatially second-order accurate representation of the solid boundaries
700 irrespective of their orientation relative to the underlying Cartesian discretisa-
701 tion. This scheme has been shown in Popinet (2003), and Popinet and Rickard
702 (2007) to compare very favourably with the simpler first-order accurate *mask-*
703 *ing* commonly used in Cartesian ocean models.

704 A.4 Adaptivity

705 The overall scheme allows for space and time-varying spatial resolution. To
706 simplify the implementation the sizes of neighbouring cells can not vary by

707 more than a factor of two (this is sometimes referred to as *restricted or graded*
708 *quad/octree*).

709 One of the advantages of the quad/octree discretisation is that mesh refine-
710 ment or coarsening are cheap and can be performed at every timestep if nec-
711 essary with a minimal impact on overall performance (usually less than 1% of
712 computation time). Interpolation of quantities on newly refined or coarsened
713 cells is also relatively simple and is done conservatively both for momentum
714 and density.

715 Several refinement criteria can be used simultaneously depending on the prob-
716 lem. Combinations of the following criteria have been used in this article:

Vorticity

$$\frac{|\nabla \times \mathbf{U}| \Delta}{\max(|\mathbf{U}|)} < \epsilon, \quad (\text{A.13})$$

717 with Δ the mesh size and ϵ a user-defined threshold. This criterion will
718 ensure that a finer resolution is used in areas of high vorticity. The threshold
719 parameter ϵ can be interpreted as the maximum angular deviation from a
720 straight path – due to the local vorticity $\nabla \times \mathbf{U}$ – of a massless particle
721 travelling at speed $\max(|\mathbf{U}|)$ across a cell of size Δ . The threshold ϵ is
722 usually set to a small value, typically 10^{-2} .

Gradient

$$|\nabla c| \Delta < \epsilon, \quad (\text{A.14})$$

723 with c a field variable. Note that the value of ϵ can be chosen differently if
724 required for each adaptive criteria.

725 **REFERENCES**

726 Almgren, A. S., J. B. Bell, and W. Y. Crutchfield, 2000. Approximate projec-
727 tion methods: Part I. Inviscid analysis, *SIAM J. Sci. Comput.*, **22**, pp1139-
728 1159.

729 Behrens, J., 2005. Adaptive atmospheric modeling: scientific computing at its
730 best, *Comput. Sci. Eng.*, **7**, pp 7683.

731 Bell, J. B., P. Colella, and H. M. Glaz, 1989. A second-order projection method
732 for the incompressible Navier-Stokes equations, *J. Comput. Phys.*, **85**, pp 257-
733 283.

734 Berntsen, J., 2000. USERS GUIDE for a modesplit σ -coordinate numerical
735 ocean model. Technical Report 135, Department of Applied Mathematics,
736 University of Bergen, Johs. Bruns gt. 12, N-5008, Bergen, Norway, 48pp.

737 Berntsen, J., J. Xing, and, G. Alendal, 2006. Assessment of non-hydrostatic
738 ocean models using laboratory scale problems. *Continental Shelf Research*, **26**,
739 pp 1433-1447.

740 Blayo, E., Debreu, L., 1999. Adaptive mesh refinement for finite difference
741 ocean models: first experiments. *Journal of Physical Oceanography*, **29**, pp
742 12391250.

743 Bogucki, D., Garrett, C., 1993. A simple model for the shear-induced decay of
744 an internal solitary wave, *Journal of Physical Oceanography*, **23**, pp 17671776.

745 Bourgault, D., Kelley, D.E., 2003. Wave-induced boundary mixing in a par-
746 tially mixed estuary. *Journal of Marine Research*, **61**, pp 553576.

747 Bourgault, D., and, D. E. Kelley, 2004. A laterally averaged nonhydrostatic
748 ocean model, *Journal of Atmospheric and Oceanic Technology*, **21**, pp 1910-
749 1924.

750 Bourgault, D., M. D. Blokhina, R. Mirshak, and, D. E. Kelley, 2007. Evolution
751 of a shoaling internal solitary wavetrain, *Geophysical Research Letters*, **34**,
752 L03601, doi:10.1029/2006GL028462.

753 Bourgault, D., and, D. E. Kelley, 2007. On the reflectance of uniform slopes for
754 normally incident interfacial solitary waves, *Journal of Physical Oceanography*,

755 **37**, pp 1156-1162.

756 Burchard, H., and, J-M. Beckers, 2004. Non-uniform adaptive vertical grids
757 in one-dimensional numerical ocean models, *Ocean Modelling*, **6**, pp 51-81.

758 Chorin, A., 1968. Numerical solution of the Navier-Stokes equations. *Mathe-*
759 *matics of Computation*, **22** (104), pp 745-762.

760 Hanert, E., E. Deleersnijder, and, V. Legat, 2006. An adaptive finite element
761 water column model using the MellorYamada level 2.5 turbulence closure
762 scheme, *Ocean Modelling*, **12**, pp 205-223.

763 Härtel, C., E. Meiburg and F. Necker, 2000. Analysis and direct numerical
764 simulation of the flow at a gravity-current head. Part 1. Flow topology and
765 front speed for slip and no-slip boundaries, *Journal of Fluid Mechanics*, **418**,
766 pp 189-212.

767 Helfrich, K.R., 1992. Internal solitary wave breaking and run-up on a uniform
768 slope, *Journal of Fluid Mechanics*, **243**, pp 133-154.

769 Helfrich, K.R., and W.K. Melville, 2006. Long nonlinear internal waves, *Annu.*
770 *Rev. Fluid Mech.*, **38**, pp 395-425.

771 Iribarren, C.R., Nogales, C., 1949. Protection des ports. Section II, Comm. 4,
772 XVIIth Int. Nav. Congress, Lisbon.

773 Marshall, J., A. Adcroft, C. Hill, L. Perelman, C. Heisey, 1997. A finite-volume,
774 incompressible Navier Stokes model for studies of the ocean on parallel com-
775 puters, *Journal of Geophysical Research*, **102(C3)**, pp 5753-5766.

776 Matsumura, Y., and H. Hasumi, 2008. A non-hydrostatic ocean model with a
777 scalable multigrid Poisson solver, *Ocean Modelling*, **24**, pp 15-28.

778 Michallet, H., and, G. N. Ivey, 1999. Experiments on mixing due to internal
779 solitary waves breaking on uniform slopes, *Journal of Geophysical Research*,
780 **104(C6)**, pp13467-13477.

781 Pain, C.C., M.D. Piggott, A.J.H. Goddard, F. Fang, G.J. Gorman, D.P. Mar-
782 shall, M.D. Eaton, P.W. Power, C.R.E. de Oliveira, 2005. Three-dimensional
783 unstructured mesh ocean modelling, *Ocean Modelling*, **10**, pp 5-33.

- 784 Piggott, M.D., G.J. Gorman, C.C. Pain, P.A. Allison, A.S. Candy, B.T. Mar-
785 tin, and M.R. Wells, 2008. A new computational framework for multi-scale
786 ocean modelling based on adapting unstructured meshes, *Int. J. Numer. Meth.*
787 *Fluids*, **56**, pp 10031015.
- 788 Popinet, S., 2003. A tree-based adaptive solver for the incompressible Euler
789 equations in complex geometries, *Journal of Computational Physics*, **190**(2),
790 pp572-600.
- 791 Popinet, S., 2006. The Gerris Flow Solver, <http://gfs.sourceforge.net>.
- 792 Popinet, S., and, G.J. Rickard, 2007. A tree-based solver for adaptive ocean
793 modelling, *Ocean Modelling*, **16**, p224-249.
- 794 Segur, H., Hammack, J.L., 1982. Soliton models of long internal waves, *Journal*
795 *of Fluid Mechanics*, **118**, pp 285304.
- 796 Simpson, A.E., 1972. Effects of the lower boundary on the head of a gravity
797 current, *J. Fluid Mech.*, **53**, pp 759-768.
- 798 Simpson, A.E., 1997. Gravity Current, Cambridge University Press.
- 799 Venayagamoorthy, S. K., and, O. B. Fringer, 2007. On the formation and
800 propagation of nonlinear internal boluses across a shelf break, *Journal of Fluid*
801 *Mechanics*, **577**, pp 137-159.

802 **LIST OF FIGURES**

- 803 (1) Experimental and model set-up. Horizontal dashed line is initial undis-
804 turbed centre of the pycnocline, with solid line illustrating initial con-
805 ditions for model perturbed pycnocline. Slope gradient is “s”, such that
806 $s = H/L_S = d_-/L$. For reference, horizontal distance from slope bottom
807 to left hand domain edge is L_R .
- 808 (2) Grid layout on slope for standard run (see text). Largest squares show
809 volumes associated with coarsest grid at level of resolution of 7. As the
810 boundary set here by the slope (the solid line) is approached, the resolu-
811 tion is increased by halving the grid size until the maximum resolution
812 (here level 9) is reached. Gerris is finite volume, and accounts for cell
813 changes in volume where cut by the boundary in order to return the
814 correct boundary fluxes.
- 815 (3) Density contours at time 7.5 s for viscosity and diffusivity values of (a)
816 6.75×10^{-5} , (b) 1.0×10^{-6} , (c) 1.5×10^{-7} , and (d) $1.5 \times 10^{-8} \text{ m}^2\text{s}^{-1}$ for
817 model experiment “d” in Table 1 in the (x,z)-plane. The height of each
818 frame is 0.075 m.
- 819 (4) Density contours at time 7.5 s for (a) standard run (see text), (b) adapting
820 to a maximum level of resolution of 12, and (c) frame(b) - frame(a) in
821 the (x,z)-plane. The height of each frame is 0.075 m.
- 822 (5) Contours of resolution levels for frame (b) in Fig. 4 from lowest resolution
823 at level 7 to finest resolution at level 12.
- 824 (6) Contours at time 37.5 s for model experiment 2 in Table 1 of (a) density,
825 (b) x component of velocity, and (c) vorticity in the (x,z)-plane, with
826 contour intervals of (a) 4.0kgm^{-3} , (b) 0.01ms^{-1} , and (c) 4.67s^{-1} . The
827 height of each frame is 0.072 m. Vertical scale is four times the horizontal
828 scale for clarity. Vertical lines locate root cells at horizontal spacing of 0.15
829 m, and horizontal line inside model domain locates initial undisturbed
830 pycnocline.
- 831 (7) Multiple bolus trajectories plotted in terms of its position relative to the
832 pycnocline-slope intersection ($x/X_{BP} = 0$) as a function of time for model
833 experiment 2 (see Table 1). Four boluses are shown moving upslope, the
834 first identified with crosses, the second squares, the third and fourth trian-
835 gles and diamonds, respectively. Horizontal dashed line locates horizontal
836 position of undisturbed pycnocline-slope intersection.
- 837 (8) Density contours for first bolus for model experiment 2 in Table 1 at
838 (times (seconds), normalised positions x/X_{BP}) (a) (22.5, -0.28), (b) (27.0,
839 -0.07), (c) (30.0, 0.06), and (d) (37.5, 0.31), respectively. Bolus trajectory
840 shown as crosses in Figure 7. Contour interval for density in kgm^{-3} for
841 frames (a,b) is 4.0, for frame (c) is 3.0, and for (d) is 2.0. Maximum

- 842 (density, bolus height, length, speed) is (a) (1047, 0.03, 0.05, 0.11), (b)
843 (1035, 0.022, 0.033, 0.084), (c) (1032, 0.017, 0.03, 0.07), and (d) (1017,
844 0.0144, 0.024, 0.047) (kgm^{-3} , m, m, ms^{-1}), respectively. Bold lines on
845 frame (b) indicate bolus height and length.
- 846 (9) Vorticity contours and velocity vectors for first bolus for model experi-
847 ment 2 in Table 1. Velocity vectors scaled proportional to the maximum
848 speed in each frame, and the contour interval for vorticity is $5.0s^{-1}$. All
849 other details for frames (a)-(d) are the same as in the caption for Fig. 8.
850 Bold lines on frame (b) indicate bolus height and length.
- 851 (10) Breaking location (criterion) as a function of λ . Characters identify indi-
852 vidual experiments 1 to 4 and a to i in Tables 1 and 2.
- 853 (11) Number of boluses in a breaking event as a function of λ . Characters
854 identify individual experiments 1 to 4 and a to i in Tables 1 and 2.
- 855 (12) Initial height of first bolus scaled by a_0 (maximum displacement of the
856 interface) as a function of λ . Characters identify individual experiments
857 1 to 4 and a to i in Tables 1 and 2.
- 858 (13) First bolus aspect ratio H/l_B (frames (a)-(c)) and first bolus height
859 (frames (d)-(f)) as a function of upslope distance for model experiments
860 as labelled in Tables 1 and 2. Dashed line in frames (d)-(f) indicates linear
861 decay of bolus height with distance.
- 862 (14) Reflection coefficient R against Iribarren number ξ for the dots (model)
863 and Michallet and Ivey (1999) experiments (crosses). Size of boxes and
864 crosses at each point indicate estimated error bounds. The bold curve
865 is the best fit to model by Bourgault and Kelley (2007) for the free slip
866 sidewalls.
- 867 (15) Energy flux (W/m) against time (seconds) for model experiments (e) to
868 (i) in Table 2.

Table 1

Initial conditions for eight test model experiments. For each of these model experiments $H = 0.15$ m, $L_R = 0.05$ m (see Figure 1), $\rho_0 = 1000 \text{ kgm}^{-3}$, and $a_i = 0.027$ m, $\Delta\rho = 47.0 \text{ kgm}^{-3}$, $\Delta h = 0.0035\text{m}$, $d_+ = z_i$, and $d_- = 0.15 - z_i$ (see equations 4 and 5). Pairs of experiments differ only in their initial z_i value, which changes subsequent a_0 and λ model values.

Model Label	slope	z_i (m)	a_0 model (cm)	λ model
1,a	0.034	0.05, 0.024	2.7, 2.6	0.053, 0.018
2,b	0.05	0.05, 0.024	2.8, 2.7	0.077, 0.026
3,c	0.128	0.05, 0.024	2.8, 2.6	0.198, 0.083
4,d	0.217	0.05, 0.024	3.0, 2.9	0.32, 0.12

Table 2

Model conditions for five selected experiment numbers (in brackets) from Michallet and Ivey (1999). For each of these model experiments $H = 0.15$ m, $L_R = 1.0$ m, (see Figure 1), $\rho_0 = 1000 \text{ kgm}^{-3}$, and $\Delta\rho$ is used in equation 4.

Model Label (Expt)	slope	z_i (m)	$\Delta\rho$ (kgm^{-3})	a_0 (cm)	L_w (cm)	ξ	λ
e (4)	0.069	0.033	20.0	2.8	31.0	0.23	0.054
f (8)	0.169	0.0255	40.0	2.6	28.0	0.55	0.098
g (12)	0.214	0.024	12.0	2.7	24.0	0.64	0.113
h (7)	0.169	0.0495	40.0	2.0	41.0	0.77	0.3
i (13)	0.214	0.06	44.0	1.8	46.0	1.08	0.64

Table 3

Experimental data for five selected experiment numbers from Michallet and Ivey (1999). Variation in experimental Iribaren number ξ is based on range of internal wave amplitudes a_0 , and a 5% error estimate in L_w by Michallet and Ivey (1999).

Expt	a_0 (cm)	L_w (cm)	ξ
4	3.0	30.0	0.21 - 0.22
8	2.8	24.0	0.48 - 0.51
12	2.5 - 3.1	24.0	0.58 - 0.67
7	2.0	46.0	0.79 - 0.83
13	1.6 - 2.0	56.0	1.1 - 1.3

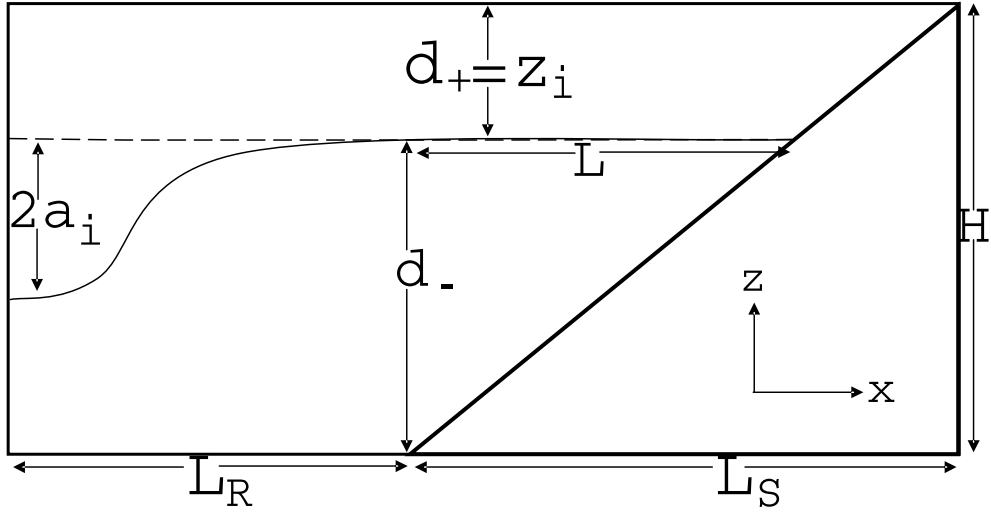

Fig. 1. Experimental and model set-up. Horizontal dashed line is initial undisturbed centre of the pycnocline, with solid line illustrating initial conditions for model perturbed pycnocline. Slope gradient is “ s ”, such that $s = H/L_S = d_-/L$. For reference, horizontal distance from slope bottom to left hand domain edge is L_R .

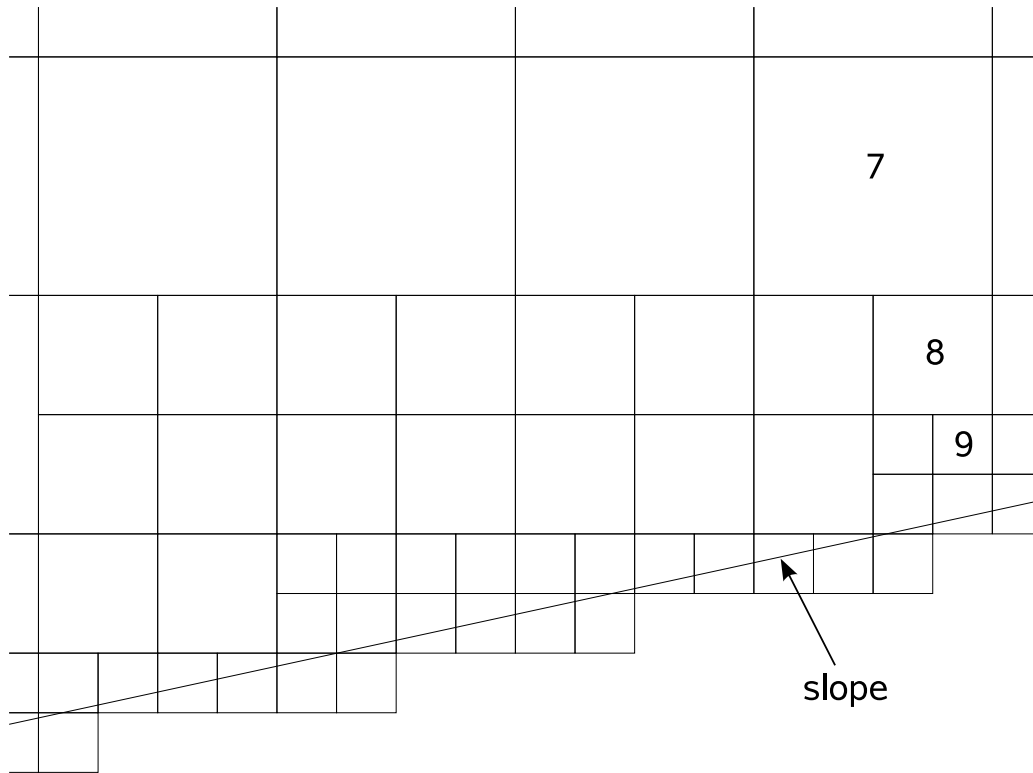

Fig. 2. Grid layout on slope for standard run (see text). Largest squares show volumes associated with coarsest grid at level of resolution of 7. As the boundary set here by the slope (the solid line) is approached, the resolution is increased by halving the grid size until the maximum resolution (here level 9) is reached. Gerris is finite volume, and accounts for cell changes in volume where cut by the boundary in order to return the correct boundary fluxes.

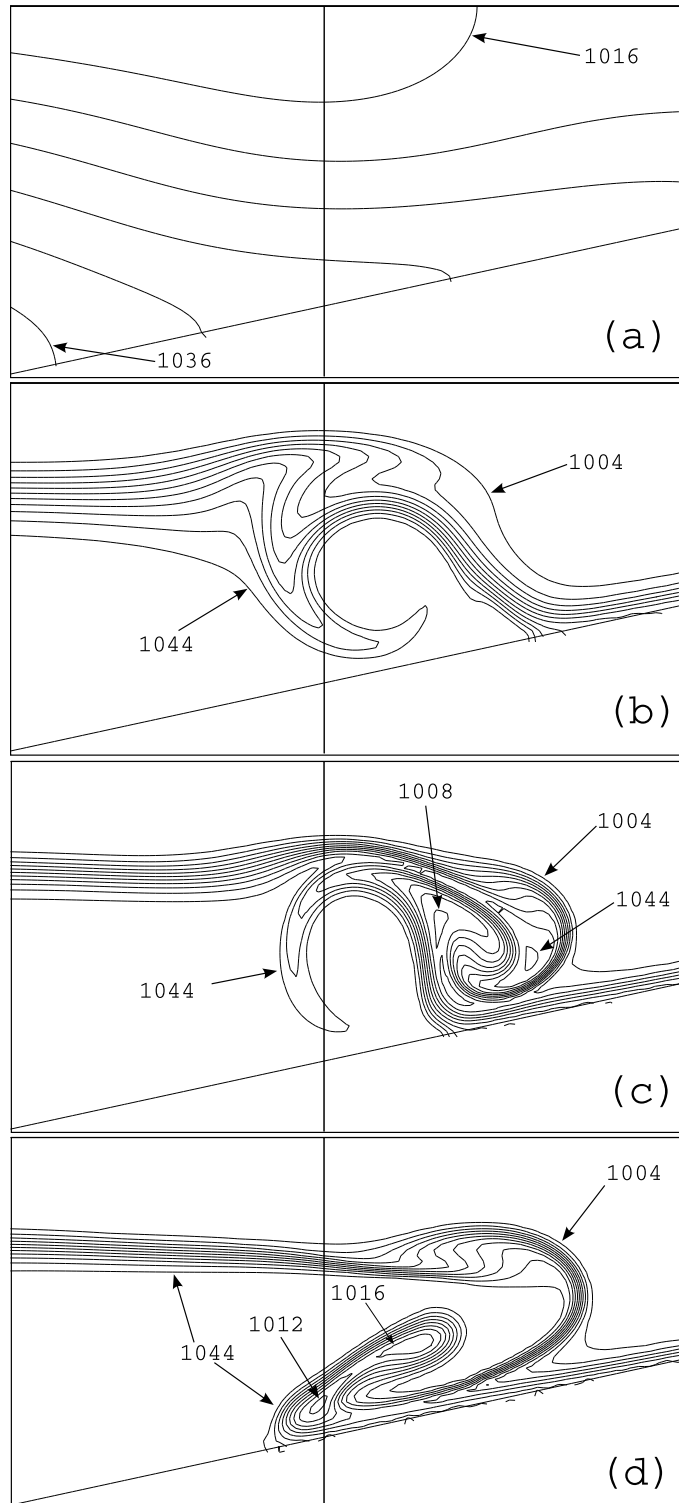

Fig. 3. Density contours at time 7.5 s for viscosity and diffusivity values of (a) 6.75×10^{-5} , (b) 1.0×10^{-6} , (c) 1.5×10^{-7} , and (d) $1.5 \times 10^{-8} \text{ m}^2\text{s}^{-1}$ for model experiment “d” in Table 1 in the (x, z)-plane. The height of each frame is 0.075 m.

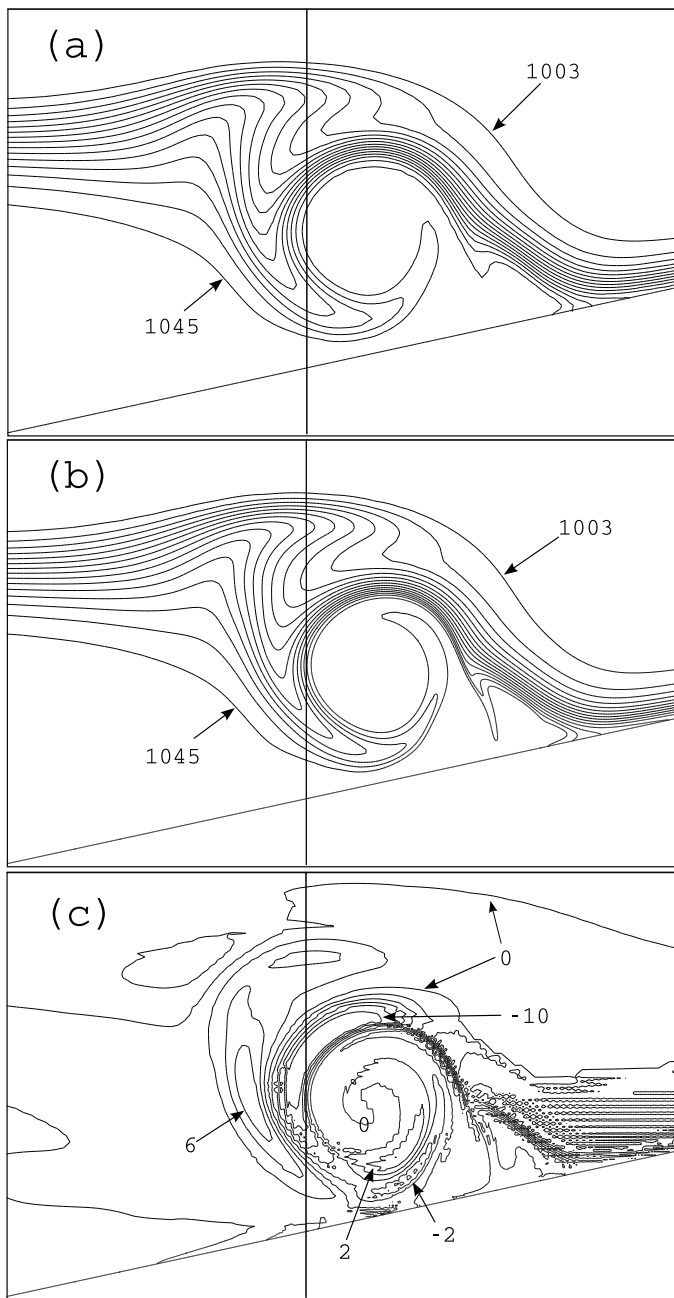

Fig. 4. Density contours at time 7.5 s for (a) standard run (see text), (b) adapting to a maximum level of resolution of 12, and (c) frame(b) - frame(a) in the (x, z)-plane. The height of each frame is 0.075 m.

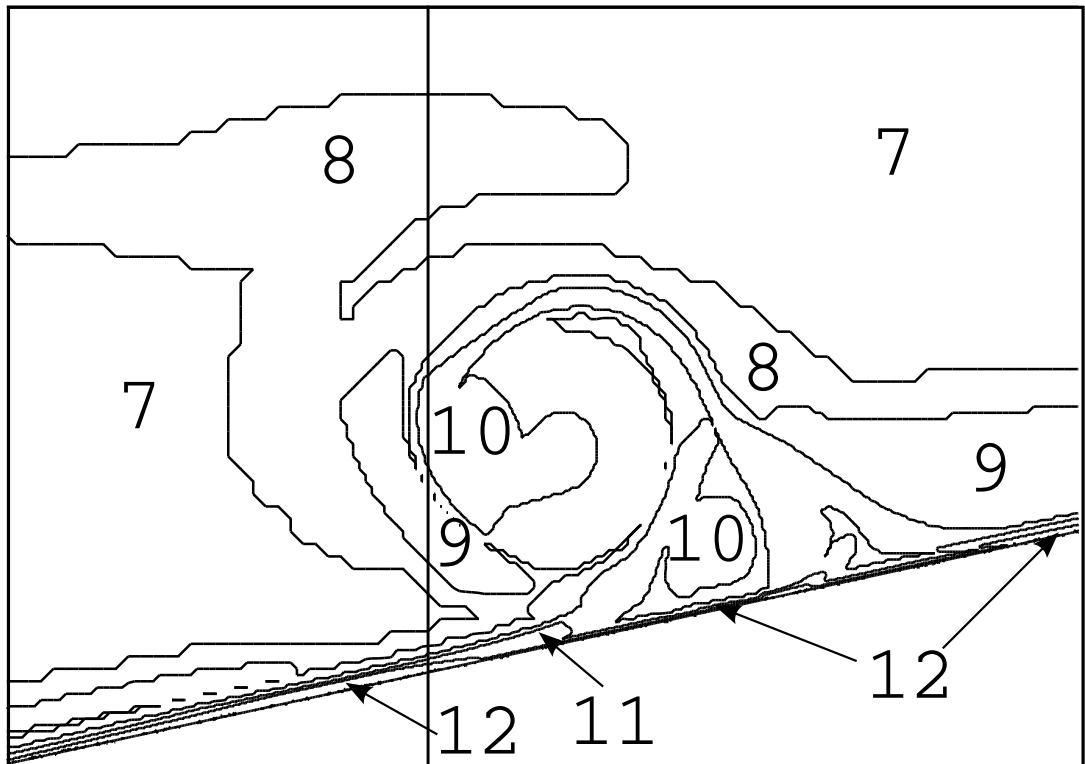

Fig. 5. Contours of resolution levels for frame (b) in Fig. 4 from lowest resolution at level 7 to finest resolution at level 12.

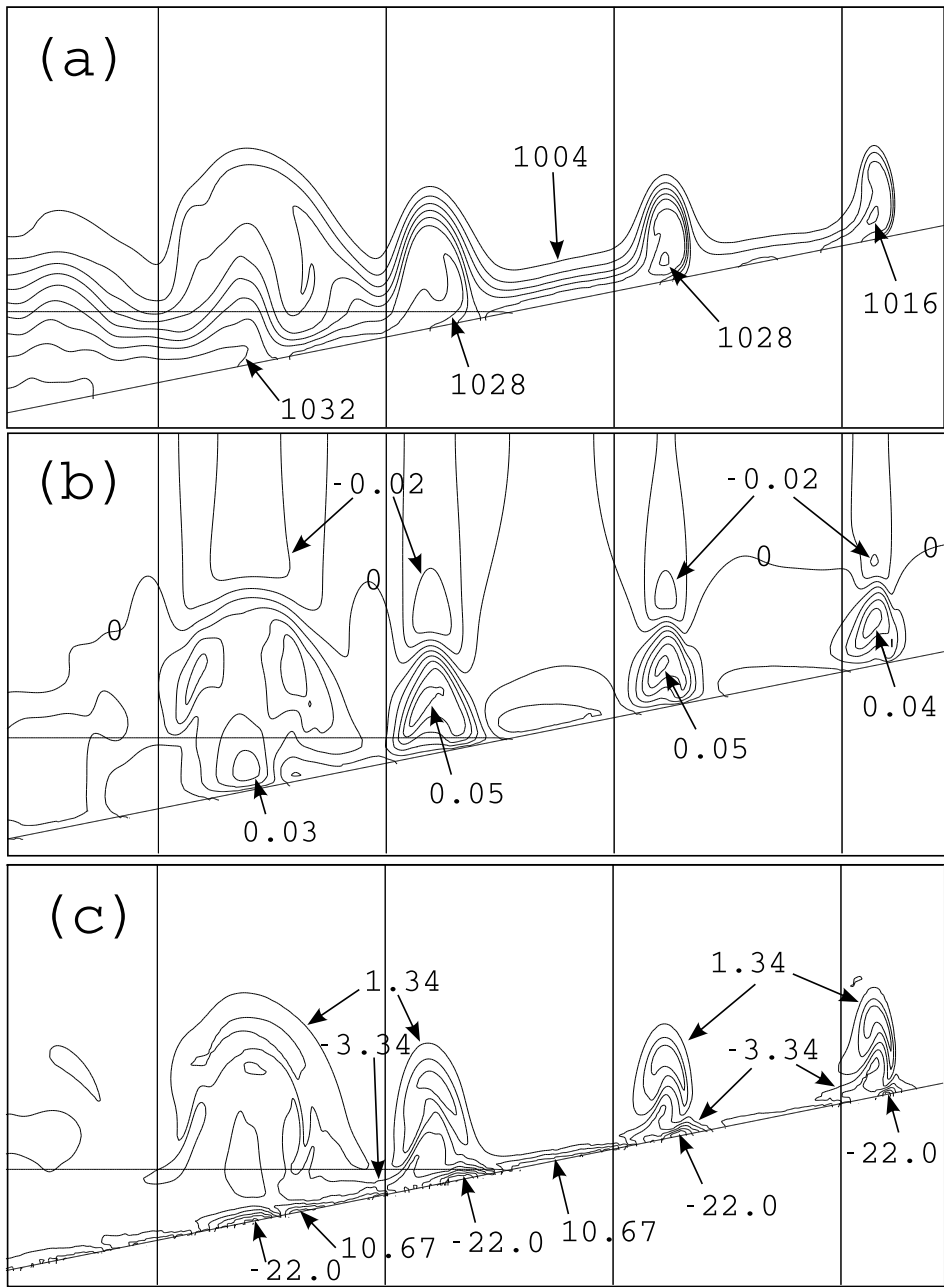

Fig. 6. Contours at time 37.5 s for model experiment 2 in Table 1 of (a) density, (b) x component of velocity, and (c) vorticity in the (x, z) -plane. The height of each frame is 0.072 m. Vertical scale is four times the horizontal scale for clarity. Vertical lines locate root cells at horizontal spacing of 0.15 m, and horizontal line inside model domain locates initial undisturbed pycnocline.

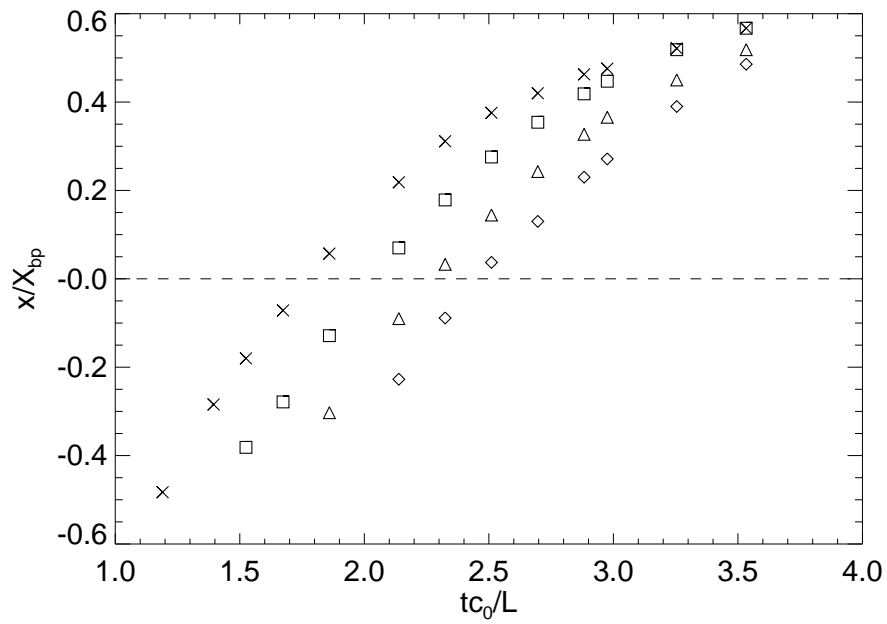

Fig. 7. Multiple bolus trajectories in time for model experiment 2 (see Table 1). Four boluses are shown moving upslope, the first identified with crosses, the second squares, the third and fourth triangles and diamonds, respectively. Horizontal dashed line locates horizontal position of undisturbed pycnocline-slope intersection.

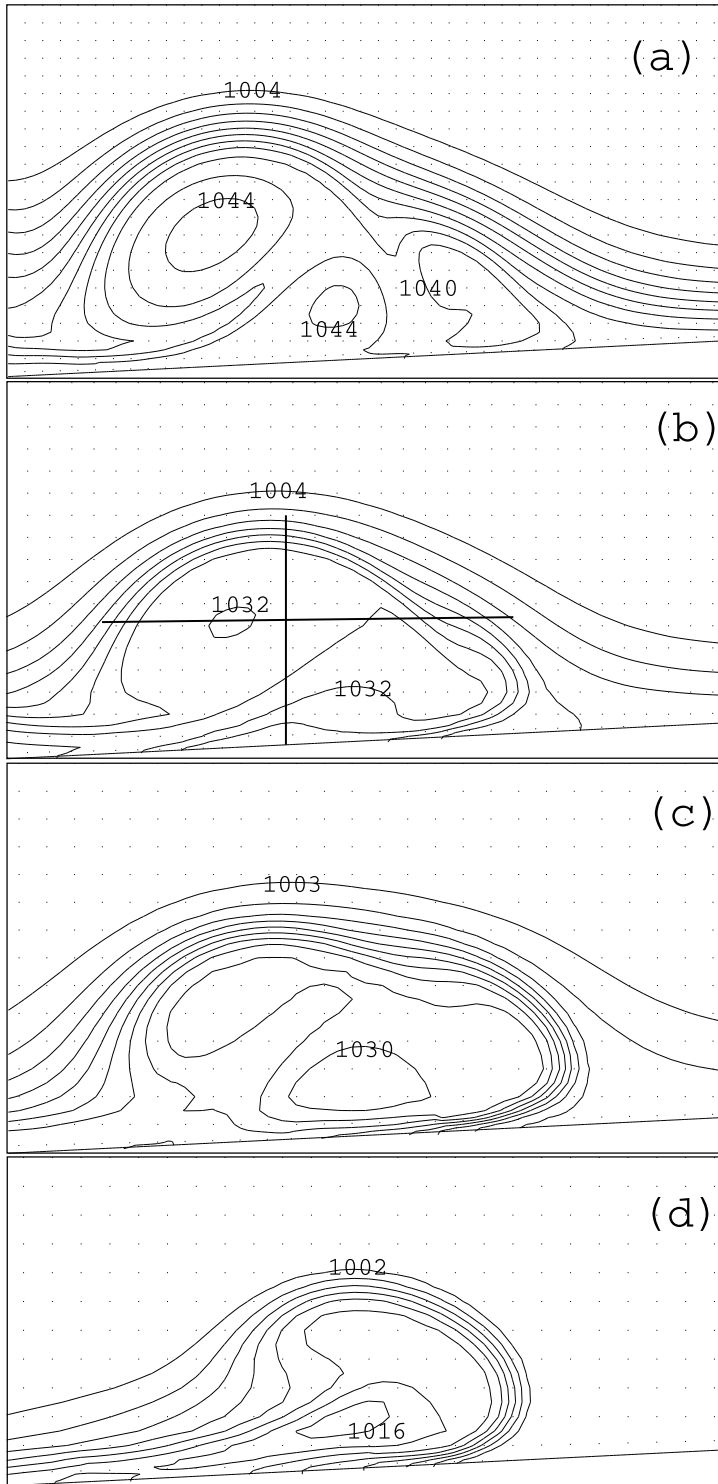

Fig. 8. Density contours for first bolus for model experiment 2 in Table 1 at (times (seconds), normalised positions x/X_{BP}) (a) (22.5, -0.28), (b) (27.0, -0.07), (c) (30.0, 0.06), and (d) (37.5, 0.31), respectively. Bolus trajectory shown as crosses in Figure 7. Contour interval for density in kgm^{-3} for frames (a,b) is 4.0, for frame (c) is 3.0, and for (d) is 2.0. Maximum (density, bolus height, length, speed) is (a) (1047, 0.03, 0.05, 0.11), (b) (1035, 0.022, 0.033, 0.084), (c) (1032, 0.017, 0.03, 0.07), and (d) (1017, 0.0144, 0.024, 0.047) (kgm^{-3} , m, m, ms^{-1}), respectively. Bold lines on frame (b) indicate bolus height and length.

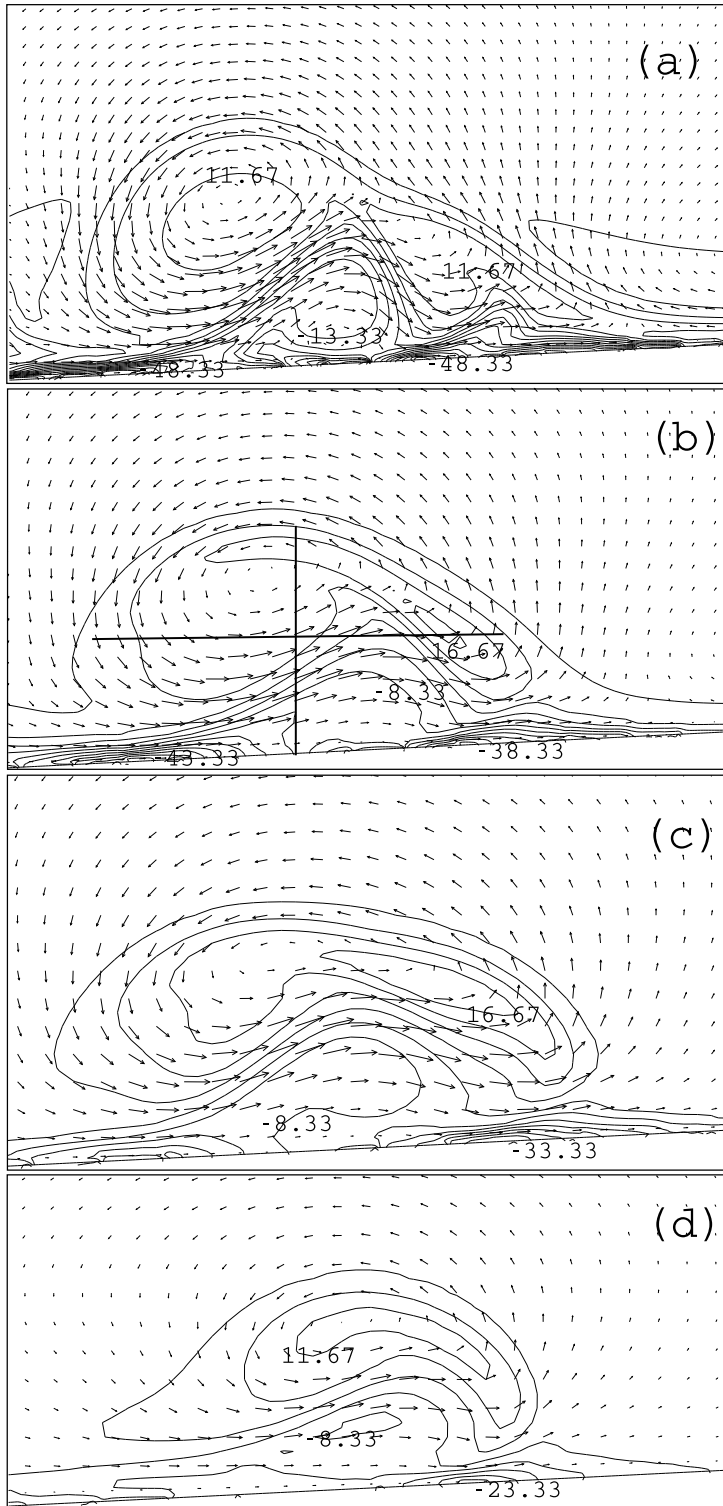

Fig. 9. Vorticity contours and velocity vectors for first bolus for model experiment 2 in Table 1. Velocity vectors scaled proportional to the maximum speed in each frame, and the contour interval for vorticity is $5.0s^{-1}$. All other details for frames (a)-(d) are the same as in the caption for Fig. 8. Bold lines on frame (b) indicate bolus height and length.

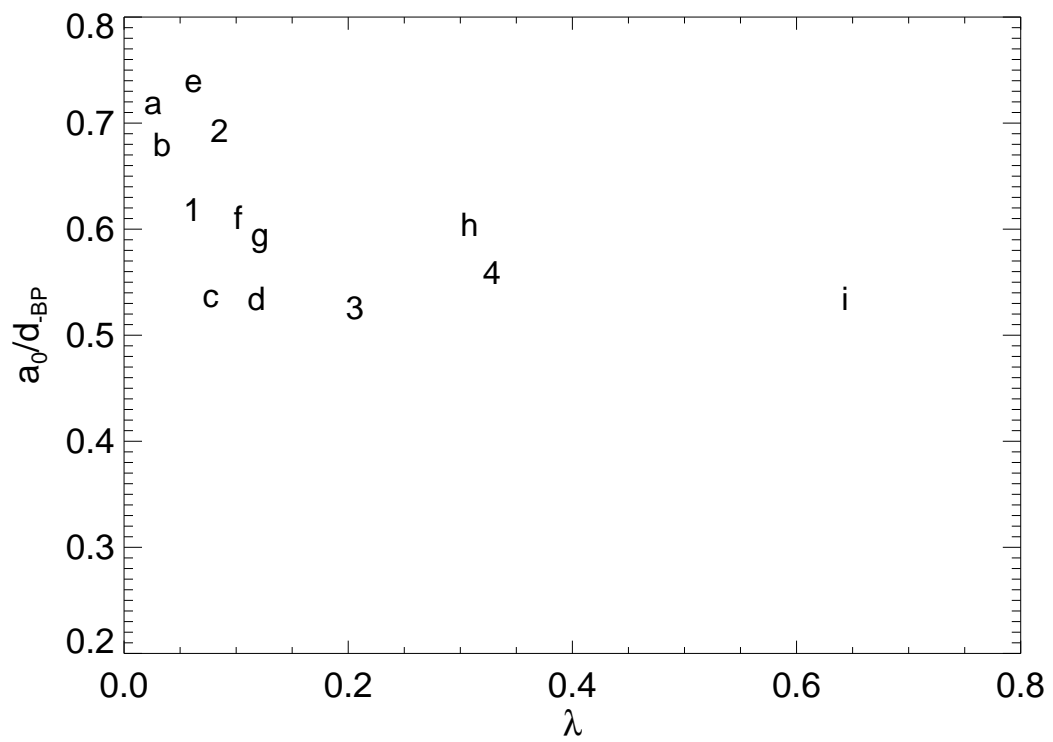

Fig. 10. Breaking location (criterion) as a function of λ . Characters identify individual experiments 1 to 4 and a to i in Tables 1 and 2.

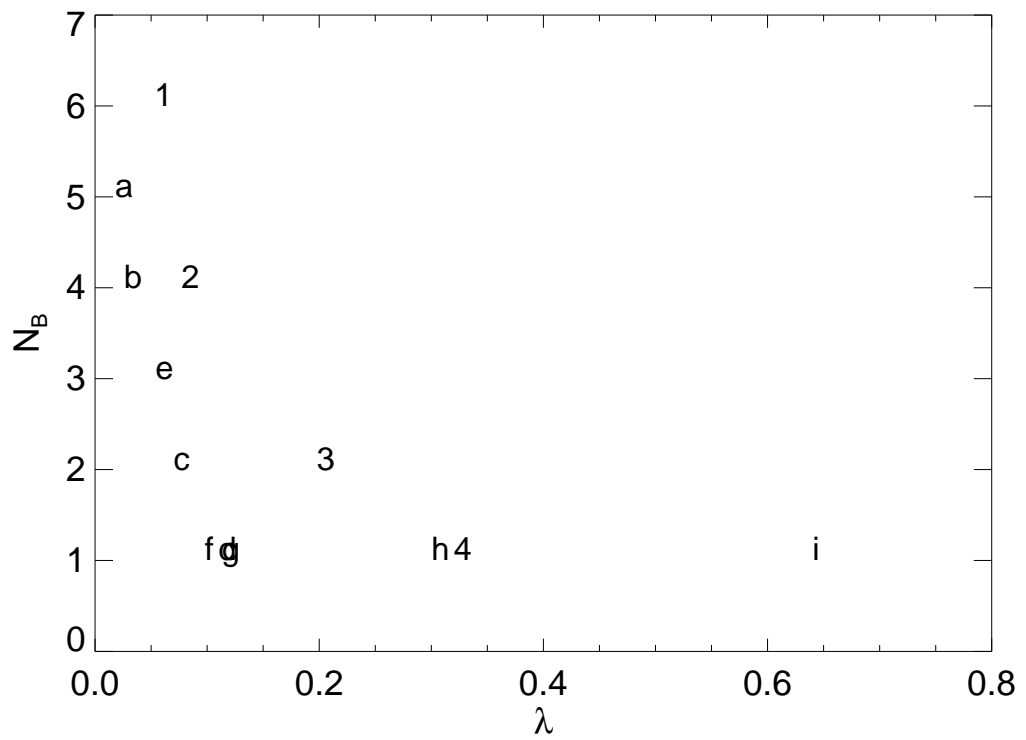

Fig. 11. Number of boluses in a breaking event as a function of λ . Characters identify individual experiments 1 to 4 and a to i in Tables 1 and 2.

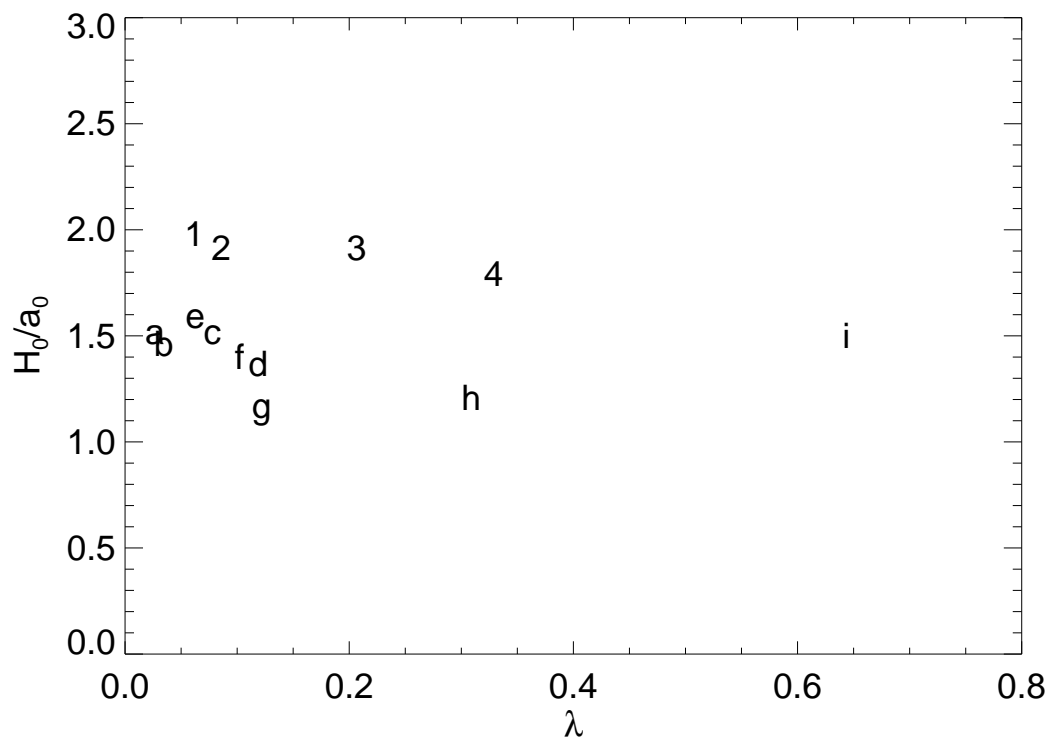

Fig. 12. Initial height of first bolus scaled by a_0 (maximum displacement of the interface) as a function of λ . Characters identify individual experiments 1 to 4 and a to i in Tables 1 and 2.

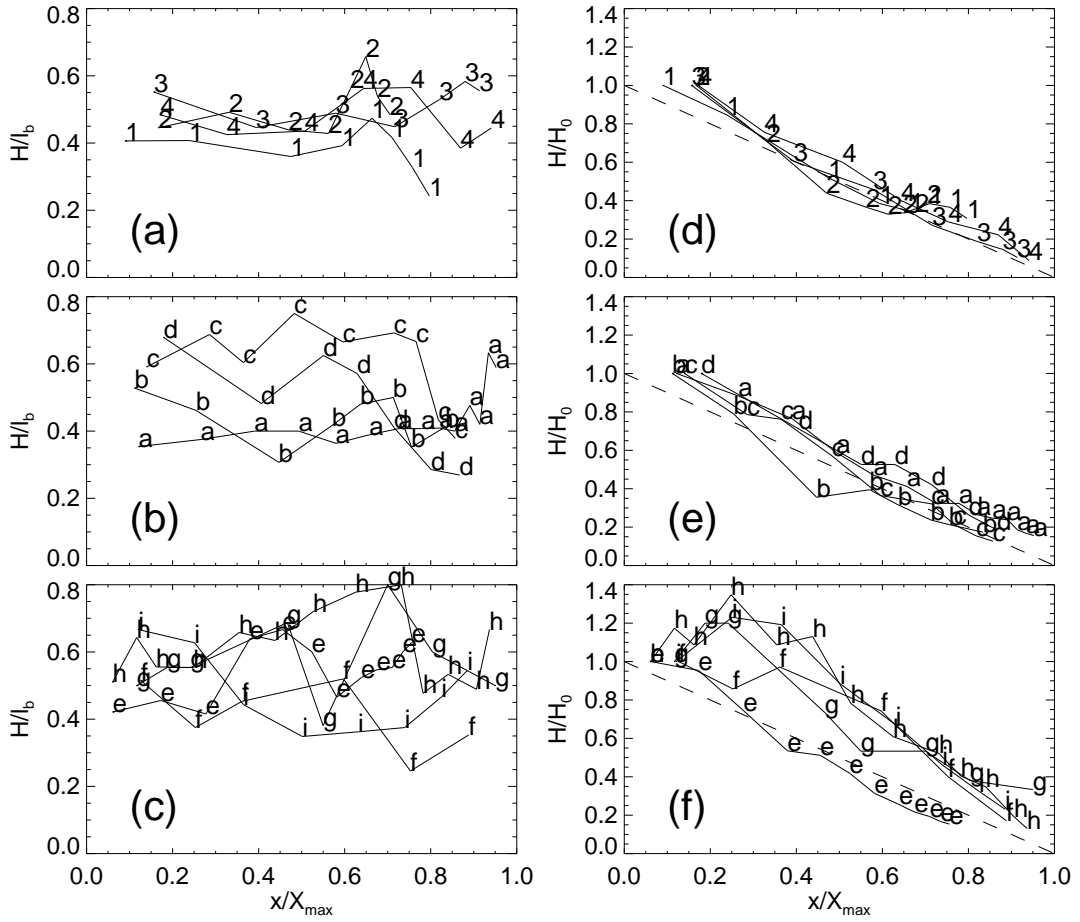

Fig. 13. First bolus aspect ratio H/l_B (frames (a)-(c)) and first bolus height (frames (d)-(f)) as a function of upslope distance for model experiments as labelled in Tables 1 and 2. Dashed line in frames (d)-(f) indicates linear decay of bolus height with distance.

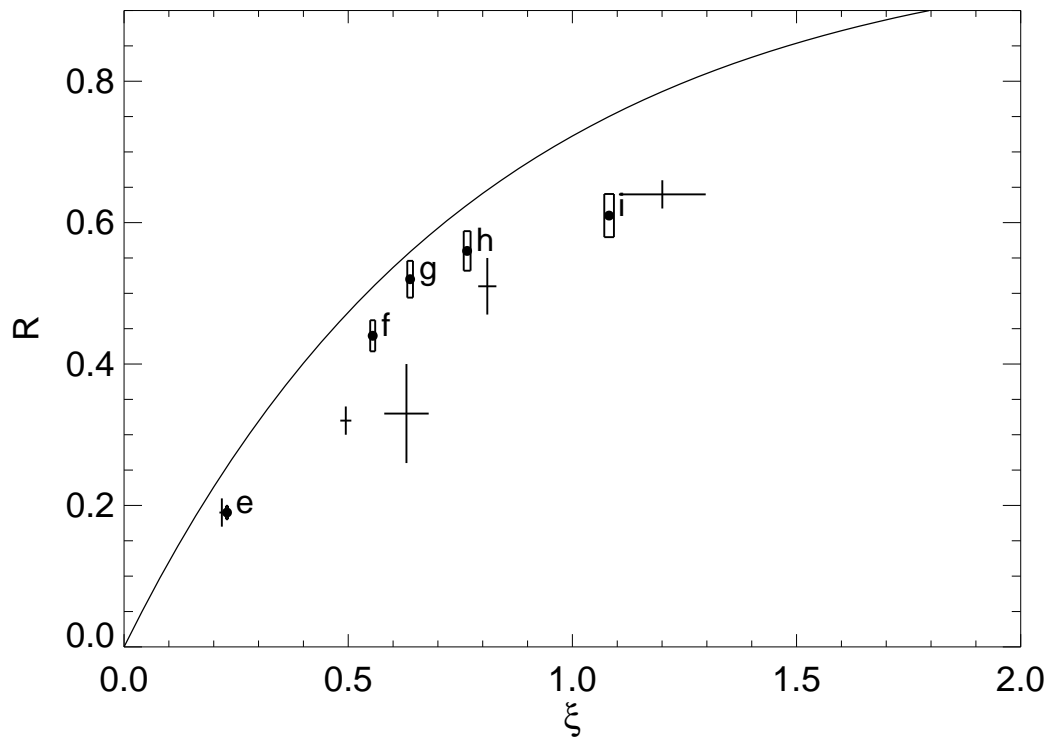

Fig. 14. Reflection coefficient R against Iribarren number ξ for the dots (model) and Michallet and Ivey (1999) experiments (crosses). Size of boxes and crosses at each point indicate estimated error bounds. The bold curve is the best fit to model by Bourgault and Kelley (2007) for the free slip sidewalls.

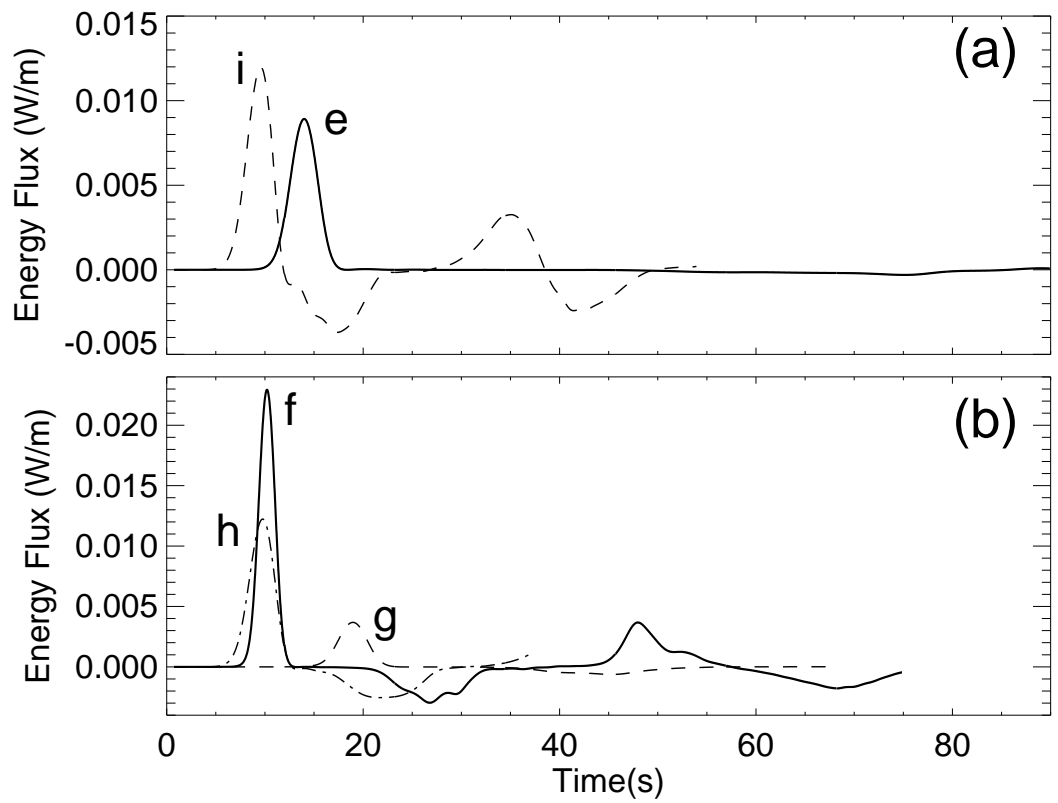

Fig. 15. Energy flux (W/m) against time (seconds) for model experiments (e) to (i) in Table 2.