



HAL
open science

Integrated process planning and system configuration for mixed-model machining on rotary transfer machine

Olga Battaïa, Alexandre Dolgui, Nikolai Guschinsky

► **To cite this version:**

Olga Battaïa, Alexandre Dolgui, Nikolai Guschinsky. Integrated process planning and system configuration for mixed-model machining on rotary transfer machine. *International Journal of Computer Integrated Manufacturing*, 2017, 30 (9), pp.910-925. 10.1080/0951192X.2016.1247989 . hal-01435089

HAL Id: hal-01435089

<https://hal.science/hal-01435089v1>

Submitted on 13 Jan 2017

HAL is a multi-disciplinary open access archive for the deposit and dissemination of scientific research documents, whether they are published or not. The documents may come from teaching and research institutions in France or abroad, or from public or private research centers.

L'archive ouverte pluridisciplinaire **HAL**, est destinée au dépôt et à la diffusion de documents scientifiques de niveau recherche, publiés ou non, émanant des établissements d'enseignement et de recherche français ou étrangers, des laboratoires publics ou privés.

Integrated process planning and system configuration for mixed-model machining on rotary transfer machine

Olga Battaïa *, **Alexandre Dolgui ****, **Nikolai Guschinsky*****

* ISAE-Supaéro, Toulouse, France (e-mail: olga.battaia@isae.fr)

** École des Mines de Nantes, CNRS UMR6597 IRCCYN, F-44307 NANTES Cedex 3, France
(e-mail: alexandre.dolgui@mines-nantes.fr)

*** Operatoinal Research Laboratory, United Institute of Informatics Problems, Academy of Sciences, Minsk, Belarus (e-mail: gyshin@newman.bas-net.by)

Abstract: New generation of rotary transfer machines processing different models of parts is considered. In order to enhance the cost-effectiveness of mixed-model rotary transfer machines, the problems of process planning for the parts to be machined and the configuration of a rotary transfer machine are integrated in the same optimisation problem. This problem is modelled as a combinatorial optimization problem. The decisions to be taken simultaneously concern the orientation of parts for machining, the machining parameters for processing the parts as well as the configuration of machining units to be used at working positions of the machine. Constraints related to the design of such units – spindle heads, turrets – and working positions, as well as precedence constraints related to machining operations, are taken into account. The problem consists in minimizing an estimated cost of the rotary transfer machine, while reaching a given output and satisfying all the constraints. The proposed methods to solve the problem are based on its MIP formulation. The optimisation techniques are validated on an industrial case study. Numerical experiments evaluate the efficiency of the approach against the variety of parts to be produced.

Keywords: Rotary machine, Product variety, Machine engineering, Production system design, Integrated process planning and system configuration, Line design and balancing, Combinatorial design, Combinatorial optimization, Industrial case study.

1. INTRODUCTION

Within the today's context of increasing demand and product diversification, companies must be able to adapt their manufacturing systems for high variety production in order to profitably produce in small quantities different models of products. Mixed-model production is the practice of processing products without changeovers in the manufacturing system (Rabbani et al., 2014). Such a production mode poses new challenges in production system design, planning and management. In order to be cost-efficient several decision problems have to be considered jointly (Leonesio et al, 2013) such as process planning, system configuration and scheduling. In literature, each of these decision problems has attracted a large amount of research interest (Xu et al., 2011, Battaïa et al. 2012b, Guschinskaya et al., 2009, Dolgui et al., 2008). However, conventionally they have been performed sequentially (Lv and Qiao, 2014). Under the

modern production constraints and global competition, the strong dependence between these issues and its influence on the profitability of product manufacturing, resource utilisation and product delivery time cannot be ignored anymore. The growing amount of research work in the direction of joint consideration of these problems proves the importance of such an integrated approach.

It should be noted that the most advanced integration is currently realized between process planning and scheduling (Phanden et al. 2013; Bensmaine et al. 2014). The primary goal of process planning is to specify raw materials or components, processes and operations needed to convert a part from its raw material to the finished form (Yin et al., 2014). Scheduling receives process plans as its input and defines an order of processing the operations on machines while satisfying the precedence relations given in process plans. Scheduling is bound by process sequencing instructions given by the process plan and constrained by time-phased availability of production resources (Li and McMahon, 2007). However, even if a great research effort was dedicated to the integration of process planning and scheduling since the pioneer study by Chryssolouris et al. (1985), it still remains of limited functionality or compensated in computational efficiency due to the NP-hard nature of both problems (Mohapatra et al. 2014). The existing approaches for these two methods are broadly categorized into two types: the progressive/enumerative approach and the simultaneous/centralised approach. A comprehensive state-of-the-art review on the integration of process planning and scheduling has been recently realized by Phanden et al. (2011).

The configuration of machine tools and process planning problems are also traditionally managed as independent stages, where the process plan is designed by considering a number of machine tool solutions available from catalogue. Despite the fact that this strategy presents a number of disadvantages in terms of process results and machine capabilities fully exploitation, the integration of these decision problems has been rarer considered in the academic literature. Szadkowski (1971) has proposed one of the first models to optimize process plans for mass production taking into account combinatorial aspects and machining constraints. A graph approach for optimisation of mass production rotary transfer machines was proposed by Dolgui et al. (2009). A decision support system for design of mass production machining lines composed of stations with rotary or mobile table was developed by Battaïa et al. (2012a). This decision system included modules for part designing, process planning, system configuration and system cost optimisation. An integrated approach for jointly configuring machine tools and process planning with the objective to optimize the production costs was developed by Leonesio et al. (2013). The problem of combinatorial customization of automated production lines with rotary transfer and turrets was addressed by Battaïa et al. (2014a). Integrated configurable equipment selection and line balancing for mass production with serial–parallel machining systems was considered by Battaïa et al. (2014b).

The studies considering reconfiguration of machining systems when it is necessary to integrate new parts to be machined requires also solving NP-hard optimization problems. For the case of mass production, where the integration of new parts is not effortless, optimisation techniques were proposed by Makssoud et al. (2014). To improve the flexibility of existing machining systems, several studies were conducted by Terkaj et al. (2009, 2010) and Copani et al (2015), Copani and Rosa (2015). Tolio and Urgo (2013) have proposed a mathematical model to assess the reconfiguration cost for flexible transfer lines. Variety-oriented design of rotary machining systems used for family part production was discussed by Battaïa et al. (2015).

Since no model available in the literature can be applied for the integrated process planning and system configuration for mixed-model machining on a rotary transfer machine, this paper develops such an optimisation model and evaluates it on an industrial case study.

The rotary transfer machine studied in this paper is used to produce simultaneously d_0 types of parts. Such machines are multi-positional, i.e. the parts are sequentially machined on m_0 (1, 2, ..., m_0) working positions. One position of the machine (zero position) is exclusively used for loading new billets and

unloading finished parts. It is assumed that the parts are loaded in sequence $\pi=(\pi_1, \pi_2, \dots, \pi_{\mu_0})$ where $\pi_i \in \{0, 1, 2, \dots, d_0\}$, $i=1, 2, \dots, \mu_0$, μ_0 is multiple to m_0+1 and $\pi_i=0$ means that no part is loaded. Using sequence π one can define in one-to-one manner function $\pi(i,k)$ of part number at the k -th working position each time when machining part π_i i.e.:

$$\pi(i,k) = \begin{cases} \pi_{i+m_0-k}, & \text{if } i+m_0-k \leq \mu_0, \\ \pi_{\text{mod}(i+m_0-k, \mu_0)}, & \text{otherwise.} \end{cases}$$

At each working position, several machining units (spindle heads or turrets) can be installed to execute the operations assigned to this position. There are vertical and horizontal units to process vertically or horizontally, respectively. A turret holds several machining tools which are applied to the parts to be machined sequentially. A horizontal turret (spindle head) can work in parallel with a vertical spindle head (but not a turret) to access to different sides of parts at a working position. A vertical spindle head can be common for several working positions, i.e. can execute simultaneously operations on all these working positions. However, only one vertical turret can be mounted at one position or one common vertical spindle head can be installed for all working positions. Only one horizontal spindle head or turret can be used per position. For example, the rotary transfer machine in Fig. 1 has one vertical spindle head common for position 1,3,4,5, two horizontal turrets on position 1 and 3, and one horizontal spindle head on position 4.

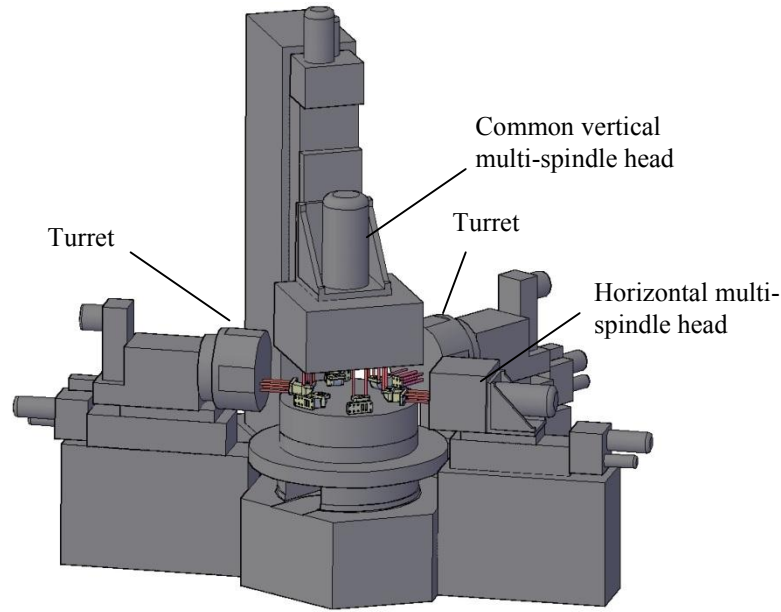

Fig. 1. A rotary transfer machine with turrets

The rest of paper is organized as follows. Section 2 describes the decision variables and input data for the joint process planning and system configuration problem for mixed-model machining on a rotary transfer machine. Sections 3 provides a mathematical model for the considered combinatorial optimization problem. An industrial example is presented in Section 4. The results of numerical experiments are given and analyzed in Section 5. Concluding remarks are reported in Section 6.

2. PROBLEM STATEMENT

2.1. Notations and definitions

Let \mathbf{N}^d be the set of machining operations needed for machining elements of the d -th part, $d=1, 2, \dots, d_0$, located on n_d sides and N_s^d , $s=1, 2, \dots, n_d$, be a subset of operations for machining elements of the s -th

side of the part. Part d can be located in different orientations, the set of all possible orientations is $\mathbf{H}(d)$ is known. Part orientation is done at zero position and still the same for all working positions. Elements of no more than one side can be machined by vertical spindle head or turret. All elements of other sides of the part have to be assigned to horizontal spindle heads or turrets. $\mathbf{H}(d)$ can be represented by matrix of dimension $r_d \times n_d$ where $h_{rs}(d)$ is equal $j, j=1,2$ if the elements of the s -th side of the part d can be machined by spindle head or turret type j .

Let $\mathbf{N} = \bigcup_{d=1}^{d_0} \mathbf{N}^d$. All operations $p \in \mathbf{N}$ are characterized by the following parameters:

- length $\lambda(p)$ of the working stroke for operation $p \in \mathbf{N}$, i.e. the distance to be run by the tool in order to complete operation p ;
- range $[\gamma_1(p), \gamma_2(p)]$ of feasible values of feed rate which characterizes the machining speed;
- set $H(p)$ of feasible orientations of the part (indexes $r \in \{1, 2, \dots, r_d\}$ of rows of matrix $\mathbf{H}(d)$) for execution of operation $p \in N_s^d$ by spindle head or turret of type j (vertical if $h_{rs}(d)=1$ and horizontal if $h_{rs}(d)=2$).

Let subset $N_k, k=1, \dots, m$, contains the operations from set \mathbf{N} assigned to the k -th working position.

Let sets N_{k1} and N_{k2} be the sets of operations assigned to working position k that are concerned by vertical and horizontal machining, respectively.

Finally, let b_{kj} be the number of machining modules (not more than b_0) of type j (vertical if $j=1$ or horizontal if $j=2$) installed at the k -th working position. Subsets $N_{kjl}, l=1, \dots, b_{kj}$ contain the operations from set N_{kj} assigned to the same machining module.

The machining process imposes numerous constraints that have to be taken into account both for process planning and machining units' configuration. In the literature, these constraints are commonly divided in the following categories (Battaia and Dolgui, 2013).

Since the machining operations naturally have precedence relationships, they have to be taken into account on the process planning step. They are expressed by a directed graph $G^{OR}=(\mathbf{N}, D^{OR})$ where an arc $(p, q) \in D^{OR}$ if and only if operation p has to be executed before operation q . It should be noted that if such operations p and q belong to different sides of the part then they cannot be executed at the same position.

Tolerance constraints impose to execute certain operations at the same working position, by the same turret, by the same spindle head or even by the same spindle (for different parts). Such inclusion constraints are modeled by undirected graphs $G^{SP}=(\mathbf{N}, E^{SP}), G^{ST}=(\mathbf{N}, E^{ST}), G^{SM}=(\mathbf{N}, E^{SM})$ and $G^{SS}=(\mathbf{N}, E^{SS})$, where edge $(p, q) \in E^{SS} ((p, q) \in E^{SM}, (p, q) \in E^{ST}, (p, q) \in E^{SP})$ if and only if operations p and q must be executed by the same spindle, machining module, turret, or at the same position, respectively.

On contrary, certain operations cannot be performed at the same working position, by the same turret or by the same spindle head for such evident reasons as tool intersections, impossibility of tool location in spindle head, turret, etc. These exclusion constraints are modeled by undirected graphs $G^{DM}=(\mathbf{N}, E^{DM}), G^{DT}=(\mathbf{N}, E^{DT}),$ and $G^{DP}=(\mathbf{N}, E^{DP}),$ where edge $(p, q) \in E^{DM} ((p, q) \in E^{DT}, (p, q) \in E^{DP})$ if and only if operations p and q cannot be executed by the same machining module, turret, or at the same position, respectively.

The configuration of each machining unit depends on the operations assigned to it. The assignment of operations together, to be executed by the same machining unit, impose additional constraints on the choice of the cutting parameters. The choice of these parameters influences the machining time for each particular part and the makespan for completing all parts.

Let $P = \langle P_1, \dots, P_k, \dots, P_{m_0} \rangle$ is a design decision with $P_k = (P_{1k11}, P_{2k11}, \dots, P_{d_0k11}, \dots, P_{1k1b_{k1}}, P_{2k1b_{k1}}, \dots, P_{d_0k1b_{k1}}, P_{1k21}, P_{2k21}, \dots, P_{d_0k21}, \dots, P_{1k2b_{k1}}, P_{2k2b_{k1}}, \dots, P_{d_0k2b_{k1}})$, $P_{dkjl} = (N_{dkjl}, \Gamma_{dkjl})$, $P_{dkj} = (P_{dkjl} | l=1, \dots, b_{kj})$, $P_{dk} = (P_{dkj} | j=1, 2)$, and $N_j = \bigcup_{d=1}^{d_0} \bigcup_{k=1}^{m_0} \bigcup_{l=1}^{b_{kj}} N_{dkjl}$, $j=1, 2$.

2.2. Machining time

The execution time $t^b(P_{dkjl})$ of all operations from N_{dkjl} with a feed per minute $\Gamma_{dkjl} \in [\max\{\gamma_1(p) | p \in N_{dkjl}\}, \min\{\gamma_2(p) | p \in N_{dkjl}\}]$ is equal to

$$t^b(P_{dkjl}) = L(N_{dkjl}) / \Gamma_{dkjl} + \tau^a,$$

where $L(N_{dkjl}) = \max\{\lambda(p) | p \in N_{dkjl}\}$, and τ^a is an additional constant time for advance and disengagement of tools.

We assume that if a turret of type j is installed at k -th position, then the execution time of all operations from N_{dkjl} is equal to

$$t^h(P_{dkj}) = \tau^g b_{kj} + \sum_{l=1}^{b_{kj}} t^b(P_{dkjl}), \quad j=1, 2,$$

where τ^g is an additional fixed time for one rotation of turret.

If the spindle head is installed, then $t^h(P_{dkj}) = t^b(P_{dkjl})$, $j=1, 2$. If all N_{dkjl} are empty, then $t^h(P_{dkj}) = 0$.

The execution time $t^p(P_{dk})$ is defined as

$$t^p(P_{dk}) = \tau^r + \max\{t^h(P_{dkj}) | j=1, 2\},$$

where τ^r is an additional constant time for table rotation.

The time $T(P)$ of execution of all corresponding operations after μ_0 turns of rotary table is defined as follows

$$T(P) = \sum_{i=1}^{\mu_0} \max\{t^p(P_{\pi(i,k)k}) | k=1, \dots, m_0\}.$$

We assume that the objective productivity is provided, if the total time $T(P)$ does not exceed a given available time T_0 .

Let C_1 , C_2 , C_3 , and C_4 be the relative costs for one position, one turret, one machining module of a turret, and one horizontal spindle head, respectively.

Since a vertical spindle head (if it presents) is common for several positions, its size (and therefore the cost) depends on the number of positions to be covered. Let k_{\min}^h and k_{\max}^h be the minimal and maximal position number for positions covered by a common vertical spindle head. Then, the cost of such a spindle head can be estimated as $C_4 + (k_{\max}^h - k_{\min}^h)C_5$, where C_5 is the relative cost for covering one additional position by a vertical spindle head.

The cost of a vertical turret can be estimated as $C_2 + C_3 b_{k1}$.

In the similar way, the cost $C(b_{k2})$ for performing set of operations N_{k2} by associated b_{k2} machining modules can be assessed as follows:

$$C(b_{k2}) = \begin{cases} 0 & \text{if } b_{k2} = 0, \\ C_4 & \text{if } b_{k2} = 1, \\ C_2 + C_3 b_{k2} & \text{if } b_{k2} > 1. \end{cases}$$

The machine cost $Q(P)$ is calculated as the total cost of all equipment used, i.e.

$$Q(P) = C_1 m + C_4 \text{sign}(|\mathbf{N}_1|) \left(1 - \sum_{k=1}^{m_0} \text{sign}(|N_{k12}|)\right) + \sum_{k=1}^{m_0} \text{sign}(|N_{k12}|) (C_2 + C_3 b_{k1}) + C_5 (k_{\max}^h - k_{\min}^h) + \sum_{k=1}^{m_0} C(b_{k2})$$

where $\text{sign}(a) = 1$ if $a > 0$, and $\text{sign}(a) = 0$ if $a \leq 0$.

The studied problem is to determine:

- an orientation for each part to be produced;
- an assignment of operations from set \mathbf{N} into subsets N_{kjl} , $k=1, \dots, m_0$, $j=1, 2$, $l=1, \dots, b_{kj}$ to be performed by machining module l of type j at working position k ;
- a feed per minute X_{dkjl} employed for each set of operations $N_{dkjl} = N_{kjl} \cap \mathbf{N}^d$, $d=1, \dots, d_0$, $k=1, \dots, m_0$, $j=1, 2$, $l=1, \dots, b_{kj}$

in such a way that the machine cost $Q(P)$ is as small as possible and all given constraints are respected.

Based on matrices $\mathbf{H}(d)$, $d=1, 2, \dots, d_0$, we can build matrix \mathbf{H} of dimension $\prod_{d=1}^{d_0} r_d \times \sum_{d=1}^{d_0} n_d$. It has to be

coordinated with inclusion constraints on turrets, machining modules and tools, i.e. we delete row r of \mathbf{H} if $h_{rs'} \neq h_{rs''}$ for $p \in N_s^{d'}$, $q \in N_s^{d''}$ and $(p, q) \in E^{SS} \cup E^{SM} \cup E^{ST}$. Each row of \mathbf{H} defines in one-to-one manner a partition of \mathbf{N} to \mathbf{N}_1 and \mathbf{N}_2 . Then, the optimal solution of the initial problem can be found as the best partition of corresponding \mathbf{N}_1 and \mathbf{N}_2 .

In the next section we present MIP formulation of this problem.

3. MIP FORMULATION

Let us introduce the following notations:

- X_{pkl} decision variable which is equal to 1 if operation p from \mathbf{N} is assigned to l -th machining module of spindle head or turret of type j at k -th position ($j=1$ if $p \in \mathbf{N}_1$ and $j=2$ if $p \in \mathbf{N}_2$)
- Y_{kjl}^d auxiliary variable which is equal to 1 if at least one operation for machining elements of d -th part is executed in l -th machining module of spindle head or turret type j at k -th position ($Y_{kjl}^d = 0$ if $\mathbf{N}_j = \emptyset$)
- Y_{kj}^d auxiliary variable which is equal to 1 if at least one operation for machining elements of d -th part is executed by a spindle head or turret of type j at k -th position ($Y_{kj}^d = 0$ if $\mathbf{N}_j = \emptyset$)
- Y_{kjl} auxiliary variable which is equal to 1 if l -th machining module of spindle head or turret of type j is installed at k -th position
- $Y_{1\min}$ auxiliary variable which is equal to k if k is the first position covered by a vertical spindle head or turret ($Y_{1\min} = 0$ if $\mathbf{N}_1 = \emptyset$)
- $Y_{1\max}$ auxiliary variable which is equal to k if k is the last position covered by a vertical spindle head or turret ($Y_{1\max} = 0$ if $\mathbf{N}_1 = \emptyset$)
- Z_k auxiliary variable which is equal to 1 if at least one operation is assigned to k -th position

- F_{kjl}^d auxiliary variable for determining the time of execution for operations from \mathbf{N}^d by l -th machining module of spindle head or turret of type j at k -th position
- F_k^d auxiliary variable for determining the time of execution of operations from \mathbf{N}^d at k -th position
- F^i auxiliary variable for determining the time of execution of all operations from \mathbf{N} when machining of part π_i is finished
- t_{pq} minimal time necessary for execution of operations p and q by the same machining module, $t_{pq} = \max(\lambda(p), \lambda(q)) / \min(\gamma_2(p), \gamma_2(q)) + \tau^a$

It is assumed that $(p, q) \in E^{DM}$ if $\min(\gamma_2(p), \gamma_2(q)) < \max(\gamma_1(p), \gamma_1(q))$.

Since a vertical spindle head has the common feed rate for all its spindles, it is possible to check the feasibility of installing a common vertical spindle head. It cannot be installed if $\max\{\gamma_1(p) | p \in \mathbf{N}_1\} > \min\{\gamma_2(p) | p \in \mathbf{N}_1\}$. The vertical turret cannot be installed if there exist operations $p \in \mathbf{N}_1$ and $q \in \mathbf{N}_2$ such that $(p, q) \in E^{SP}$ or operations $p \in \mathbf{N}_1$ and $q \in \mathbf{N}_1$ such that $(p, q) \in E^{DT} \cup E^{DP}$. If both above cases for spindle head and turret are identified, then the problem has no solution.

The objective function is as follows:

$$\begin{aligned} \text{Min } & C_1 \sum_{k=1}^{m_0} Z_k + C_4 \sum_{k=1}^{m_0} Y_{k21} + (C_2 + 2C_3 - C_4) \sum_{k=1}^{m_0} \sum_{j=1}^2 Y_{kj2} + \\ & C_3 \sum_{k=1}^{m_0} \sum_{j=1}^2 \sum_{l=3}^{b_0} Y_{kjl} + C_4 Y_1 + C_5 (Y_{1\max} - Y_{1\min}) \end{aligned} \quad (1)$$

If an horizontal turret is installed at position k , then $Y_{k21} = Y_{k22} = 1$ and $C_4 Y_{k21} + (C_2 + 2C_3 - C_4) Y_{k22} = C_2 + 2C_3$. If an horizontal spindle head is installed at position k , then $Y_{k2l} = 0$, $l = 2, \dots, b_0$, and $C_4 Y_{k21} + (C_2 + 2C_3 - C_4) Y_{k22} = C_4$. If a vertical turret is installed at position k , then $Y_{k11} = Y_{k12} = 1$, $Y_1 = 1$, $Y_{1\min} = Y_{1\max}$ and $(C_2 + 2C_3 - C_4) Y_{k12} + C_4 Y_1 + C_5 (Y_{1\max} - Y_{1\min}) = C_2 + 2C_3$. If a vertical spindle head is common for positions $k_1 = Y_{1\min}, \dots, k_v = Y_{1\max}$, then $Y_1 = 1$, $Y_{k1l} = 0$, $l = 2, \dots, b_0$, $k = 1, \dots, m_0$ and $C_4 Y_1 + (C_2 + 2C_3 - C_4) \sum_{k=1}^{m_0} Y_{k12} = C_4$.

Variables Z_k , $k = 1, \dots, m_0$ should satisfy the following constraints:

$$Z_k \leq Y_{k11} + Y_{k21}; \quad k = 1, \dots, m_0 \quad (2)$$

$$Y_{k11} + Y_{k21} \leq 2Z_k; \quad k = 1, \dots, m_0 \quad (3)$$

If $\mathbf{N}_1 \neq \emptyset$, variables $Y_{1\min}$ and $Y_{1\max}$ can be defined by the following constraints:

$$(m_0 - k + 1) Y_{k11} + Y_{1\min} \leq m_0 + 1; \quad k = 1, \dots, m_0 \quad (4)$$

$$Y_{1\max} \geq k Y_{k11}; \quad k = 1, \dots, m_0 \quad (5)$$

The following constraints define Y_{kjl}^d , Y_{kj}^d , and Y_{kjl} . They take 1, if and only if the corresponding sums are not equal to 0.

$$Y_{kjl}^d \leq \sum_{p \in \mathbf{N}_j \cap \mathbf{N}^d} X_{pkl}; \quad d = 1, \dots, d_0; \quad k = 1, \dots, m_0; \quad j = 1, 2; \quad l = 1, \dots, b_0 \quad (6)$$

$$\sum_{p \in \mathbf{N}_j \cap \mathbf{N}^d} X_{pkl} \leq |\mathbf{N}_j \cap \mathbf{N}^d| Y_{kjl}^d; \quad d = 1, \dots, d_0; \quad k = 1, \dots, m_0; \quad j = 1, 2; \quad l = 1, \dots, b_0 \quad (7)$$

$$Y_{kjl} \leq \sum_{d=1}^{d_0} Y_{kjl}^d ; k=1, \dots, m_0; j=1, 2; l=1, \dots, b_0 \quad (8)$$

$$\sum_{d=1}^{d_0} Y_{kjl}^d \leq d_0 Y_{kjl}; k=1, \dots, m_0; j=1, 2; l=1, \dots, b_0 \quad (9)$$

$$Y_{kj}^d \leq \sum_{l=1}^{b_0} Y_{kjl}^d ; d=1, \dots, d_0; k=1, \dots, m_0; j=1, 2 \quad (10)$$

$$\sum_{l=1}^{b_0} Y_{kjl}^d \leq b_0 Y_{kj}^d ; d=1, \dots, d_0; k=1, \dots, m_0; j=1, 2; l=1, \dots, b_0 \quad (11)$$

The constraints which prohibit empty machining modules are:

$$Y_{kjl-1} \geq Y_{kjl}; k=1, \dots, m_0; j=1, 2; l=2, \dots, b_0 \quad (12)$$

A vertical turret cannot be combined with any other machining module at the same position:

$$Y_{k12} + Y_{k21} \leq 1; k=1, \dots, m_0 \quad (13)$$

If any vertical turret cannot be installed, then the following equations should be satisfied:

$$Y_{k1l} = 0; k=1, \dots, m_0; l=2, \dots, b_0 \quad (14)$$

Otherwise:

$$Y_{k11} = Y_{k12}; k=1, \dots, m_0 \quad (14')$$

Each operation is assigned to one block, this constraints is expressed as follows:

$$\sum_{k=1}^{m_0} \sum_{l=1}^{b_0} X_{pkl} = 1 ; p \in \mathbf{N} \quad (15)$$

If operation p is assigned to l -th machining module of spindle head or turret of type j at k -th position, each operation q , predecessor of p , has to be executed at a previous position or to be assigned to a previous machining module of the corresponding turret:

$$\sum_{k=1}^{m_0} \sum_{l=1}^{b_0} ((k-1)b_0 + l) X_{pkl} \leq \sum_{k=1}^{m_0} \sum_{l=1}^{b_0} ((k-1)b_0 + l - 1) X_{qkl} ; (p, q) \in D^{OR}; p, q \in \mathbf{N}_j; j=1, 2 \quad (16)$$

$$\sum_{k=1}^{m_0} \sum_{l=1}^{b_0} k X_{pkl} \leq \sum_{k=1}^{m_0} \sum_{l=1}^{b_0} (k-1) X_{qkl} ; (p, q) \in D^{OR}; p \in \mathbf{N}_j; q \in \mathbf{N}_{3-j}; j=1, 2 \quad (17)$$

Precedence constraints can be modelled as follows:

$$\sum_{k'=1}^{k-1} \sum_{l'=1}^{b_0} X_{pk'l'} + \sum_{l'=1}^{l-1} X_{pkl'} \geq X_{qkl} ; (p, q) \in D^{OR}; p, q \in \mathbf{N}_j; j=1, 2 \quad (17')$$

$$\sum_{k'=1}^{k-1} \sum_{l'=1}^{b_0} X_{pk'l'} \geq X_{qkl} ; (p, q) \in D^{OR}; p \in \mathbf{N}_j; q \in \mathbf{N}_{3-j}; j=1, 2 \quad (18')$$

or

$$\sum_{p \in Pred(q)} \sum_{k'=1}^{k-1} \sum_{l'=1}^{b_0} X_{pk'l'} + \sum_{p \in Pred(q) \cap \mathbf{N}_j} \sum_{l'=1}^{l-1} X_{pkl'} \geq |Pred(q)| X_{qkl} ; q \in \mathbf{N}_j; j=1, 2 \quad (17'')$$

where $Pred(q) = \{p \in \mathbf{N} | (p, q) \in D^{OR}\}$.

For operations p and q that have to be performed at the same working position or by the same turret:

$$\sum_{l=1}^{b_0} X_{pkl} = \sum_{l=1}^{b_0} X_{qkl} ; (p,q) \in E^{SP} \cup E^{ST} ; k=1, \dots, m_0 \quad (19)$$

For operations p and q that have to be performed by tools of the same machining module or by the same spindle:

$$X_{pkl} = X_{qkl} ; (p,q) \in E^{SM} \cup E^{SS} ; k=1, \dots, m_0 ; l=1, \dots, b_0 \quad (20)$$

For operations p and q that have to be executed at different working positions:

$$\sum_{l=1}^{b_0} X_{pkl} + \sum_{l=1}^{b_0} X_{qkl} \leq 1, (p,q) \in E^{DP} ; k=1, \dots, m_0 \quad (21)$$

For operations p and q that have to be executed by tools of different turrets, if turrets are used, but can also be executed by the same spindle head:

$$\sum_{l=1}^{b_0} X_{pkl} + \sum_{l=1}^{b_0} X_{qkl} + Y_{kj2} \leq 2, (p,q) \in E^{DT} ; p,q \in \mathbf{N}_j ; k=1, \dots, m_0 ; j=1,2 \quad (22)$$

For operations p and q that have to be executed by tools of different machining modules:

$$X_{pkl} + X_{qkl} \leq 1 ; (p,q) \in E^{DB} ; k=1, \dots, m_0 ; l=1, \dots, b_0 \quad (23)$$

The time of execution of operations from \mathbf{N}^d by l -th machining module of spindle head or turret of type j at k -th position cannot be less than the time of execution of any operation from \mathbf{N}^d assigned to this machining module:

$$F_{kjl}^d \geq t_{qq} X_{qkl} ; q \in \mathbf{N}^d \cap \mathbf{N}_j ; j=1,2 ; d=1, \dots, d_0 ; k=1, \dots, m_0 ; l=1, \dots, b_0 \quad (24)$$

The time of execution of operations from \mathbf{N}^d by l -th machining module of spindle head or turret of type j at k -th position cannot be less than the time of execution of any pair of operations from \mathbf{N}^d assigned to this machining module:

$$F_{kjl}^d \geq t_{pq} (X_{pkl} + X_{qkl} - 1) ; p, q \in \mathbf{N}^d \cap \mathbf{N}_j ; j=1,2 ; d=1, \dots, d_0 ; k=1, \dots, m_0 ; l=1, \dots, b_0 \quad (25)$$

If a vertical spindle head can be installed (i.e. $\max\{\gamma_1(p) | p \in \mathbf{N}_1\} \leq \min\{\gamma_2(p) | p \in \mathbf{N}_1\}$), then:

$$F_{k11}^d \geq (\lambda(p)/\gamma_2(q) + \tau^a)(X_{pk1} + X_{qk'1} - 1) ; p, q \in \mathbf{N}^d \cap \mathbf{N}_1 ; d=1, \dots, d_0 ; k, k'=1, \dots, m_0 ; k \neq k' \quad (26)$$

The time of execution of operations from \mathbf{N}^d at k -th position cannot be less than the time of execution of vertical and horizontal spindle head or turret:

$$F_k^d \geq \sum_{l=1}^{b_0} F_{kjl}^d + 2\tau^g Y_{kj2} + \tau^g \sum_{l=3}^{b_0} Y_{kjl} + b_0 \tau^g (Y_{kj}^d - 1) ; d=1, \dots, d_0 ; k=1, \dots, m_0 ; j=1,2 \quad (27)$$

If a turret of type j with b_{kj} machining modules is installed at k -th position, then $F_k^d \geq \sum_{l=1}^{b_{kj}} F_{kjl}^d + b_0 \tau^g$, if at

least one operation from \mathbf{N}^d is executed by the turret and $F_k^d = 0$, otherwise. If a spindle head of type j is installed at k -th position, then $F_k^d \geq F_{kjl}^d$.

The constraint on the throughput is respected if:

$$F^i \geq F_k^{\pi(i,k)} + \tau^r ; i=1, \dots, \mu_0 ; k=1, \dots, m_0 \quad (28)$$

$$\sum_{i=1}^{\mu_0} F^i \leq T_0 \quad (29)$$

Principal decision variables are binary:

$$X_{pkl} \in \{0,1\}; p \in \mathbf{N}; k=1,\dots,m_0; l=1,\dots,b_0 \quad (30)$$

$$Y_{kj}^d \in \{0,1\}; k=1,\dots,m_0; d=1,\dots,d_0; j=1,2 \quad (31)$$

$$Y_{kjl}^d \in \{0,1\}; k=1,\dots,m_0; j=1,2; l=1,\dots,b_0; d=1,\dots,d_0 \quad (32)$$

$$Y_{kjl} \in \{0,1\}; k=1,\dots,m_0; j=1,2; l=1,\dots,b_0 \quad (33)$$

$$Y_{1\min}, Y_{1\max} \in \{0,1,\dots, m_0\}; k=1,\dots,m_0; j=1,2; l=1,\dots,b_0 \quad (34)$$

$$Z_k \in \{0,1\}; k=1,\dots,m_0 \quad (35)$$

Auxiliary decision variables are real and bounded:

$$F_{kjl}^d \in [0, \bar{t}_k^d - \tau^r]; k=1,\dots,m_0; j=1,2; l=1,\dots,b_0; d=1,\dots,d_0 \quad (36)$$

$$F_k^d \in [0, \bar{t}_k^d - \tau^r]; k=1,\dots,m_0; d=1,\dots,d_0 \quad (37)$$

$$F^i \in [\underline{T}^i, \bar{T}^i]; i=1,\dots,\mu_0 \quad (38)$$

where

$$\underline{t}^d = \min \{ \lambda(p) / \gamma_2(p) + \tau^a + \tau^r \mid p \in \mathbf{N}^d \}$$

$$\underline{T}^i = \max \{ \underline{t}^{\pi(i,k)} \mid k=1,\dots,m_0 \}$$

$$\bar{T}^i = T_0 - \sum_{i'=1, i' \neq i}^{\mu_0} \underline{T}^{i'} \quad \text{and} \quad \bar{t}_k^d = \max \{ \bar{T}^i \mid i=1,\dots,\mu_0, \pi(i,k) = d \}$$

Model (1) - (38) can be transformed by excluding constraints (20). In this case, family E^{SSM} is created of such subsets e of \mathbf{N} that include all operations connected by an edge from E^{SS} or E^{SM} . Then, constraints (15) – (19) and (21) – (26) are modified by leaving only one operation from each set $e \in E^{SSM}$. The efficiency of such a transformation is evaluated in the experimental study presented in Section 5.

4 AN INDUSTRIAL EXAMPLE

A rotary machine is designed for machining 6 different parts presented in Figures 2-7.

Parameters of machining operations are given in Table 1. Operations to be realized for parts 1, 2, 3 and 6 are located on two different sides and all operations for parts 4 and 5 are located on only one side. The sequence of loading parts is $\{1,2,5,-,3,4,-,6\}$ where “-“ means that no part is loaded.

The possible orientations of the parts are defined by the following expressions: $\mathbf{H}(1)=\mathbf{H}(2)=\mathbf{H}(3)=\mathbf{H}(6)=\begin{pmatrix} 1,2 \\ 2,1 \end{pmatrix}$, $\mathbf{H}(4)=\mathbf{H}(5)=\begin{pmatrix} 1 \\ 2 \end{pmatrix}$. The total number of possible orientations of all parts is $64=2^6$.

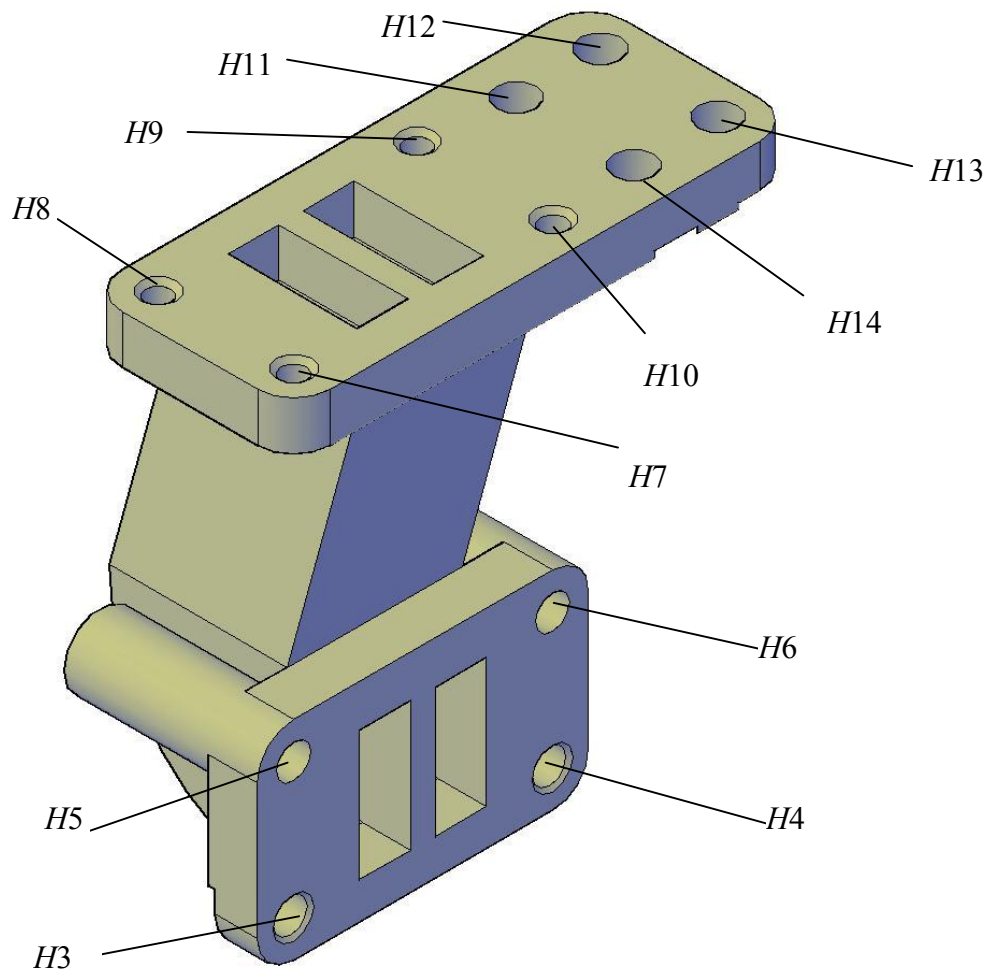

Fig.2. The first part to be machined

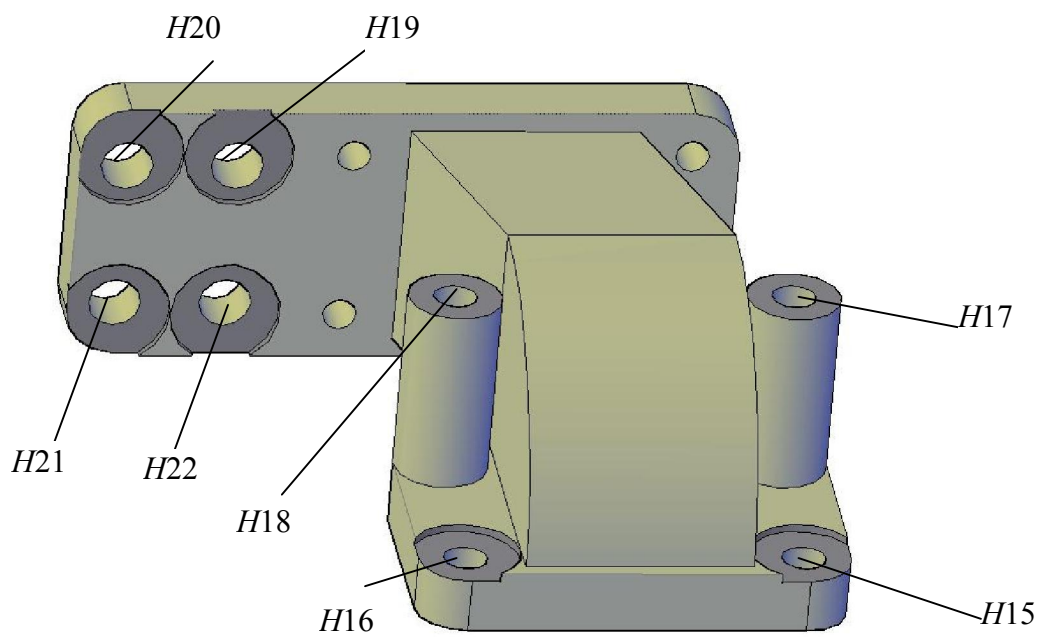

Fig.3. The second part to be machined

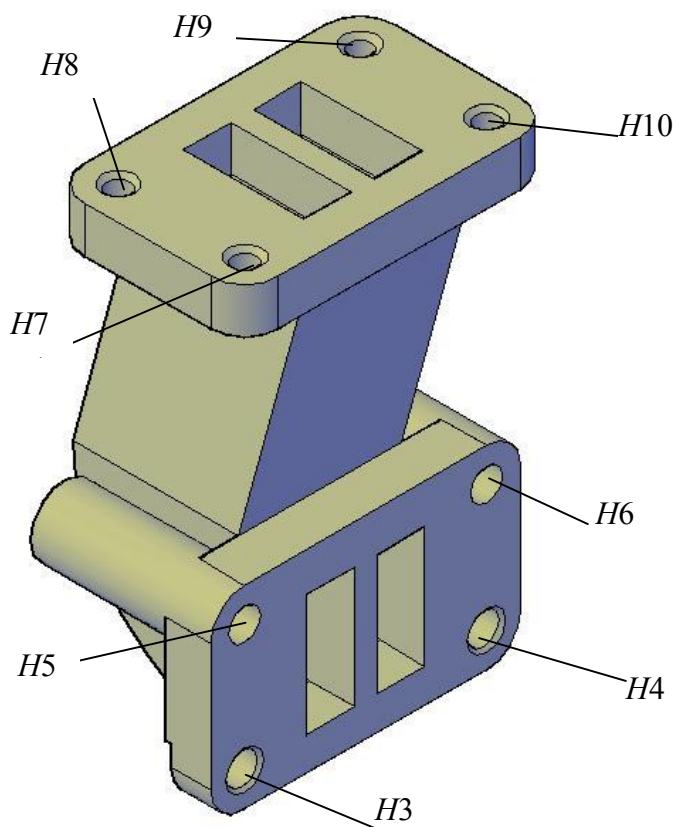

Fig.4. The third part to be machined

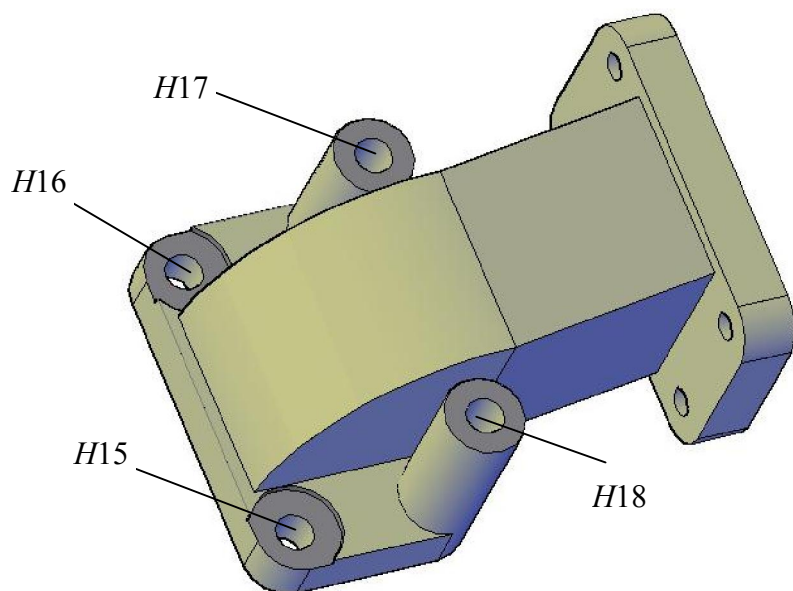

Fig.5. The fourth part to be machined

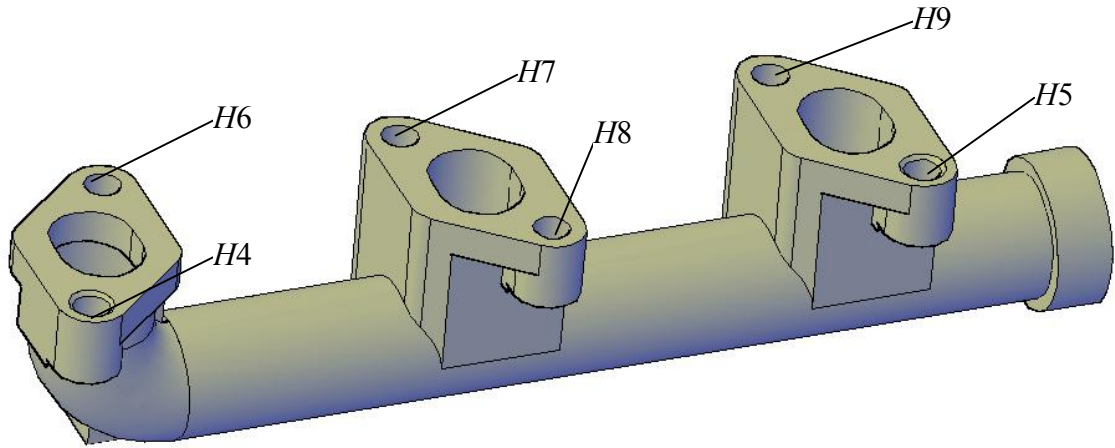

Fig.6. The fifth part to be machined

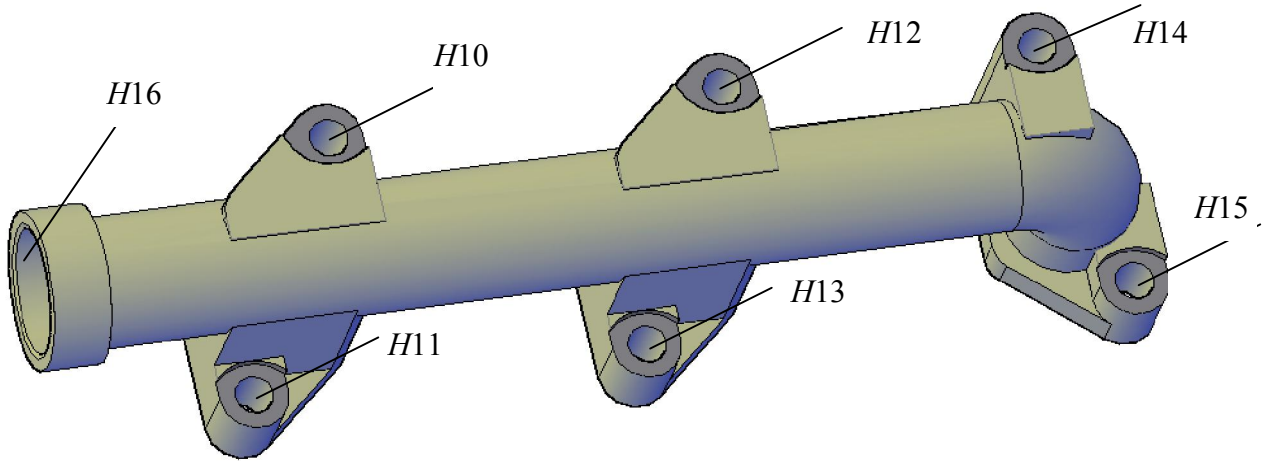

Fig.7. The sixth part to be machined

Table 1. Operations and their parameters

p	Hole	Part	Side	$\lambda(p)$, mm	$\gamma_1(p)$, mm/min	$\gamma_2(p)$, mm/min	p	Hole	Part	Side	$\lambda(p)$, mm	$\gamma_1(p)$, mm/min	$\gamma_2(p)$, mm/m in
1	H3	1	1	34	37.7	63.4	36	H6	3	1	75	29.7	105.7
2	H3	1	1	22	27.8	249.5	37	H7	3	2	24	24.6	83.6
3	H4	1	1	34	37.7	63.4	38	H7	3	2	9	28.3	106.3
4	H4	1	1	22	27.8	249.5	39	H8	3	2	24	24.6	83.6
5	H5	1	1	79	22.8	81.3	40	H8	3	2	9	28.3	106.3
6	H5	1	1	75	29.7	105.7	41	H9	3	2	24	24.6	83.6
7	H6	1	1	79	22.8	81.3	42	H9	3	2	9	28.3	106.3
8	H6	1	1	75	29.7	105.7	43	H10	3	2	24	24.6	83.6
9	H7	1	2	24	24.6	83.6	44	H10	3	2	9	28.3	106.3
10	H7	1	2	9	28.3	106.3	45	H15	4	1	2	18.8	62.7
11	H8	1	2	24	24.6	83.6	46	H16	4	1	2	18.8	62.7
12	H8	1	2	9	28.3	106.3	47	H17	4	1	2	18.8	62.7
13	H9	1	2	24	24.6	83.6	48	H18	4	1	2	18.8	62.7
14	H9	1	2	9	28.3	106.3	49	H4	5	1	53	39.2	62.9
15	H10	1	2	24	24.6	83.6	50	H4	5	1	34	27.2	248

16	H10	1	2	9	28.3	106.3	51	H5	5	1	53	39.2	62.9
17	H11	1	2	25	22	82.2	52	H5	5	1	34	27.2	248
18	H12	1	2	25	22	82.2	53	H6	5	1	100	22.8	81.3
19	H13	1	2	25	22	82.2	54	H6	5	1	98	29.7	105.7
20	H14	1	2	25	22	82.2	55	H7	5	1	100	22.8	81.3
21	H15	2	1	2	18.8	62.7	56	H7	5	1	98	29.7	105.7
22	H16	2	1	2	18.8	62.7	57	H8	5	1	45	22.8	81.3
23	H17	2	1	2	18.8	62.7	58	H8	5	1	43	29.7	105.7
24	H18	2	1	2	18.8	62.7	59	H9	5	1	100	22.8	81.3
25	H19	2	2	2	18.8	62.7	60	H9	5	1	98	29.7	105.7
26	H20	2	2	2	18.8	62.7	61	H16	6	1	30	43.7	74.1
27	H21	2	2	2	18.8	62.7	62	H16	6	1	24	31.9	197.1
28	H22	2	2	2	18.8	62.7	63	H16	6	1	24	26.9	161.6
29	H3	3	1	34	37.7	63.4	64	H16	6	1	18	26.7	160.2
30	H3	3	1	22	27.8	249.5	65	H10	6	2	3	15.5	51.6
31	H4	3	1	34	37.7	63.4	66	H11	6	2	3	15.5	51.6
32	H4	3	1	22	27.8	249.5	67	H12	6	2	3	15.5	51.6
33	H5	3	1	79	22.8	81.3	68	H13	6	2	3	15.5	51.6
34	H5	3	1	75	29.7	105.7	69	H14	6	2	3	15.5	51.6
35	H6	3	1	79	22.8	81.3	70	H15	6	2	3	15.5	51.6

Precedence constraints, exclusion constraints for machining modules, turrets and working positions are presented in Tables 2, 3, 4 and 5, respectively. Inclusion constraints for positions and machining modules are given in Tables 6 and 7. Operations to be executed by the same spindle are presented in Table 8.

Table 2. Precedence constraints

Operation	Predecessors	Operation	Predecessors
2	1 3 29 31	40	9 11 13 15 37 39 41 43
4	1 3 29 31	42	9 11 13 15 37 39 41 43
6	5 7 33 35	44	9 11 13 15 37 39 41 43
8	5 7 33 35	50	49 51
10	9 11 13 15 37 39 41 43	52	14 42 49 51 64
12	9 11 13 15 37 39 41 43	54	53 55 59
14	9 11 13 15 37 39 41 43	56	53 55 59
16	9 11 13 15 37 39 41 43	58	57
30	1 3 29 31	60	53 55 59
32	1 3 29 31	62	61
34	5 7 33 35	63	62
36	5 7 33 35	64	63
38	9 11 13 15 37 39 41 43		

Table 3. Incompatibility of operations in machining modules

Operations	Incompatible operations
2	1
4	3
6	5
8	7
9	1 2 3 4 5 6 7 8
10	1 2 3 4 5 6 7 8 9
11	1 2 3 4 5 6 7 8
12	1 2 3 4 5 6 7 8 11
13	1 2 3 4 5 6 7 8
14	1 2 3 4 5 6 7 8 13
15	1 2 3 4 5 6 7 8
16	1 2 3 4 5 6 7 8 15
17	1 2 3 4 5 6 7 8 13 14
18	1 2 3 4 5 6 7 8 17
19	1 2 3 4 5 6 7 8 18
20	1 2 3 4 5 6 7 8 15 16 17 19
23	21
24	22
25	21 22 23 24
26	21 22 23 24 25
27	21 22 23 24 25 26
28	21 22 23 24 25 26 27
29	2 9 10 11 12 13 14 15 16 17 18 19 20
30	1 9 10 11 12 13 14 15 16 17 18 19 20 29
31	4 9 10 11 12 13 14 15 16 17 18 19 20
32	3 9 10 11 12 13 14 15 16 17 18 19 20 31
33	6 9 10 11 12 13 14 15 16 17 18 19 20
34	5 9 10 11 12 13 14 15 16 17 18 19 20 33
35	8 9 10 11 12 13 14 15 16 17 18 19 20
36	7 9 10 11 12 13 14 15 16 17 18 19 20 35
37	1 2 3 4 5 6 7 8 10 29 30 31 32 33 34 35 36
38	1 2 3 4 5 6 7 8 9 29 30 31 32 33 34 35 36 37
39	1 2 3 4 5 6 7 8 12 29 30 31 32 33 34 35 36
40	1 2 3 4 5 6 7 8 11 29 30 31 32 33 34 35 36 39
41	1 2 3 4 5 6 7 8 14 17 29 30 31 32 33 34 35 36
42	1 2 3 4 5 6 7 8 13 17 29 30 31 32 33 34 35 36 41
43	1 2 3 4 5 6 7 8 16 20 29 30 31 32 33 34 35 36
44	1 2 3 4 5 6 7 8 15 20 29 30 31 32 33 34 35 36 43
45	23 25 26 27 28
46	24 25 26 27 28
47	21 25 26 27 28 45
48	22 25 26 27 28 46
50	49
52	51
54	53
56	55
58	57
60	59

62	61
63	61 62
64	61 62 63
65 66 67 68 69 70	61 62 63 64

Table 4. Incompatibility of operations in turrets

Operations	Incompatible operations
9 10 11 12 13 14 15 16 17 18 19 20	1 2 3 4 5 6 7 8
25 26 27 28	21 22 23 24
29 30 31 32 33 34 35 36	9 10 11 12 13 14 15 16 17 18 19 20
37 38 39 40 41 42 43 44	1 2 3 4 5 6 7 8 29 30 31 32 33 34 35 36
45 46 47 48	25 26 27 28
61	9 10 11 12 13 14 15 16 17 18 19 20 37 38 39 40 41 42 43 44
65 66 67 68 69 70	61 62 63 64

Table 5. Incompatibility of operations in working positions

Operations	Incompatible operations
2	1
3 29	2
30	1 3 29
31	2 30
61	25

Table 6. Operations to be assigned to the same position

Operation	Operations to be to the same position	Operation	Operations to be to the same position
25	26 27 28	61	62 63 64

Table 7. Operations to be assigned to the same machining module

Operation	Operations to be executed by the same machining module	Operation	Operations to be executed by the same machining module
1	3	33	35
5	7	34	36
6	8	37	39 41 43
9	11 13 15	49	51
17	19	53	55 59
18	20	54	56 60
29	31		

Table 8. Operations to be executed by the same spindle

Operation	Operations to be executed by the same tool	Operation	Operations to be executed by the same tool
1	29	11	39
2	30	12	40
3	31	13	41
4	32	14	42
5	33	15	43
6	34	16	44
7	35	21	45
8	36	22	46
9	37	23	47
10	38	24	48

The total number of feasible orientations of all the parts is reduced to 16 due to constraints from Table 7. Other parameters of a rotary transfer machine are: $\tau^a = \tau^g = \tau^r = 0.1$ min. The available time T_0 is 13.2 min.

First, we solve problem (1) – (38) using academic version of CPLEX 12.2. The obtained optimal solution and its characteristics are presented in Tables 9 and 10. The number of variables in the model (1) – (38) is 1224 and the number of constraints is 5521. The solution time was 1.31 sec. The common vertical spindle head cover positions 2 and 3. Only parts 1, 2, 3 are machined at position 1 where a horizontal turret with 4 machining units is installed for machining these parts. Parts 1, 2, 3, 4, 5 are machined at position 2, and all the parts are machined at position 3. There are installed the horizontal turret with 4 machining modules for (parts 1, 2, 3; parts 1, 2, 3; parts 1, 2, 3; part 2) at the position 1 and the horizontal turret with 4 machining modules for part 6 at the position 2. The rotary table turns 1.65 min after the start, then in 2.14 min, 2.1 min, 1.73 min, 1.65 min, 0.24 min, 1.92 min, and in 1.73 min respectively. The total time for machining all parts of the batch is 13.16 min.

Table 9. An optimal solution

Set N_{dkjl}	Operations of N_{dkjl}	$L(N_{dkjl})$	γ_{dkjl}	$t^b(P_{dkjl})$
N_{1121}	9 11 13 15	24	83.6	0.39
N_{2121}	26	2	62.7	0.13
N_{3121}	37 39 41 43	24	83.6	0.39
N_{1122}	10 14 18 20	25	82.2	0.4
N_{2122}	27	2	62.7	0.13
N_{3122}	38 42	9	106.3	0.18
N_{1123}	12 16 17 19	25	82.2	0.4
N_{2123}	28	2	62.7	0.13
N_{3123}	40 44	9	106.3	0.18
N_{2124}	25	2	62.7	0.13
N_{1211}	1 3 5 7	79	51.6	1.63
N_{2211}	22 23	2	51.6	0.14
N_{3211}	29 31 33 35	79	51.6	1.63
N_{4211}	46 47	2	51.6	0.14
N_{5211}	49 51 53 55 57 59	100	51.6	2.04
N_{6221}	61	40	74.1	0.64
N_{6222}	62	24	197.1	0.22
N_{6223}	63	24	161.6	0.25
N_{6224}	64	18	160.2	0.21
N_{1311}	2 4 6 8	75	51.6	1.55
N_{2311}	21 24	2	51.6	0.14

N_{3311}	30 32 34 36	75	51.6	1.55
N_{4311}	45 48	2	51.6	0.14
N_{5311}	50 52 54 56 58 60	98	51.6	2.0
N_{6311}	65 66 67 68 69 70	3	51.6	0.16

Table 10. Characteristics of the optimal solution

Position p	$t^p(P_{1k})$	$t^p(P_{2k})$	$t^p(P_{3k})$	$t^p(P_{4k})$	$t^p(P_{5k})$	$t^p(P_{6k})$
1	1.79	1.02	1.25	0.1	0.1	0.1
2	1.73	0.24	1.73	0.24	2.14	1.92
3	1.65	0.24	1.65	0.24	2.1	0.26

Then, we solve problem (1) – (38) again with CPLEX 12.2 but by using the reduction of constraints (20) as explained in Section 2. The obtained optimal solution and its characteristics are presented in Tables 11 and 12. The number of variables in the model is 828 and the number of constraints is 4824. The solution time was 1.21. There is the vertical spindle head common for positions 2 and 3. Parts 1, 2, 3, 4, 5 are machined at the position 2, and all the parts are machined at the position 3. There are installed the horizontal turret with 4 machining modules (part 6; part 6; part 6; part 6) at the position 1 and the horizontal turret with 4 machining modules (part 2; parts 1, 2, 3; parts 1, 2, 3; parts 1, 2, 3) at the position 2. The rotary table turns 1.65 min after the start, then in 2.14 min, 2.1 min, 1.73 min, 1.65 min, 1.92 min, 0.1 min, and in 1.73 min, respectively. The total time for machining all parts of the batch is 13.02 min.

Table 11. An optimal solution

Set N_{dkjl}	Operations of N_{dkjl}	$L(N_{dkjl})$	γ_{dkjl}	$t^p(P_{dkjl})$
N_{6121}	61	40	74.1	0.64
N_{6122}	62	24	197.1	0.22
N_{6123}	63	24	161.6	0.25
N_{6124}	64	18	160.2	0.21
N_{1211}	1 3 5 7	79	51.6	1.63
N_{2211}	22 23	2	51.6	0.14
N_{3211}	29 31 33 35	79	51.6	1.63
N_{4211}	46 47	2	51.6	0.14
N_{5211}	49 51 53 55 59 57	100	51.6	2.04
N_{2221}	28	2	62.7	0.13
N_{1222}	9 11 13 15	24	83.6	0.39
N_{2222}	26	2	62.7	0.13
N_{3222}	37 39 41 43	24	83.6	0.39
N_{1223}	12 16 17 19	25	82.2	0.4
N_{2223}	25	2	62.7	0.13
N_{3223}	40 44	9	106.3	0.18
N_{1224}	10 14 18 20	25	82.2	0.4
N_{2224}	27	2	62.7	0.13
N_{3224}	38 42	9	106.3	0.18
N_{1311}	2 4 6 8	75	51.6	1.55
N_{2311}	21 24	2	51.6	0.14
N_{3311}	30 32 34 36	75	51.6	1.55
N_{4311}	45 48	2	51.6	0.14
N_{5311}	50 52 54 56 60 58	98	51.6	2.0
N_{6311}	65 66 67 68 69 70	3	51.6	0.16

Table 12. Characteristics of the optimal solution

Position k	$t^p(P_{1k})$	$t^p(P_{2k})$	$t^p(P_{3k})$	$t^p(P_{4k})$	$t^p(P_{5k})$	$t^p(P_{6k})$
1	0.1	0.1	0.1	0.1	0.1	1.92
2	1.73	1.02	1.73	0.24	2.14	0.1
3	1.65	0.24	1.65	0.24	2.1	0.26

Finally, the summary of the generated models and obtained results for different combinations of constraints (20), (17) – (18), (17') – (18'), and (17'') is presented in Table 13.

Table 13. Characteristics of the models

Constraints (20)	Precedence constraints	Number of variables	Number of constraints	Time solution (sec)
	(17) – (18)	1224	5521	1.314
Yes	(17') – (18')	1224	6797	1.571
	(17'')	1224	5741	1.575
	(17) – (18)	828	4824	1.207
No	(17') – (18')	828	5000	1.226
	(17'')	828	4940	1.295

The locations of parts at the loading position and the general view of the designed rotary transfer machine according to the solution from Table 9 are presented in Fig. 2 and Fig. 3.

5. EXPERIMENTAL STUDY

The purpose of this study is to evaluate the effectiveness of the proposed optimization approach. Series of 100 test instances for 4, 6 and 8 different parts were generated. Their characteristics are presented in Fig. 10-11 and Tables 14-16, where $|N|$ is the number of operations, OSP is the order strength of precedence constraints, DM, DT, DP, SS, and SM are the densities of graphs G^{DM} , G^{DT} , G^{DP} , G^{SS} , and G^{SM} , respectively. The constraints were generated using the techniques and software presented in (Dolgui *et al*, 2008). Experiments were carried out on ASUS notebook (1.86 Ghz, 4 Gb RAM) with academic version of CPLEX 12.2.

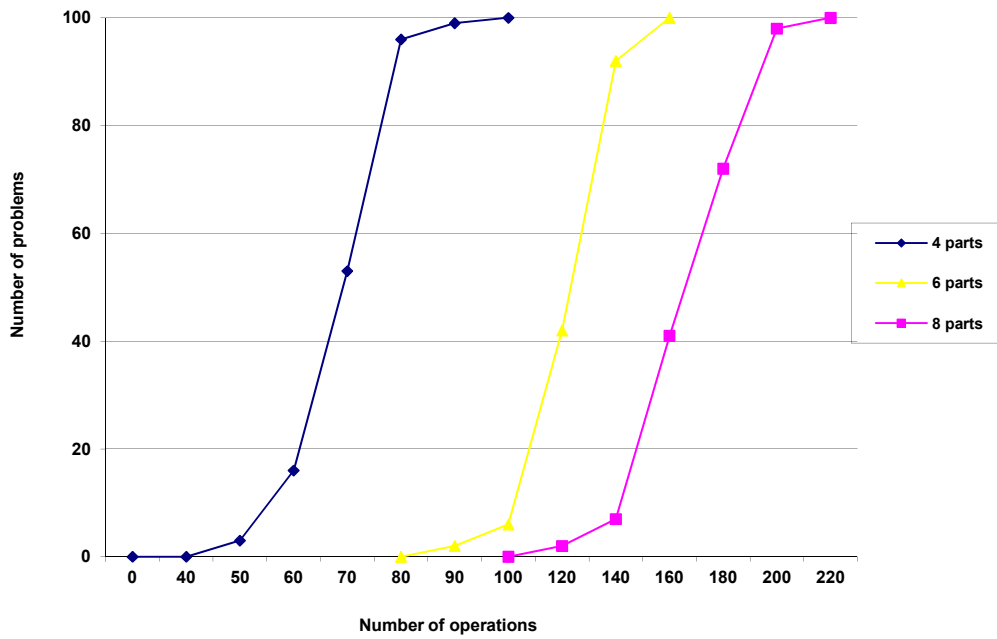

Fig. 10 Characteristics of test instances (number of operations)

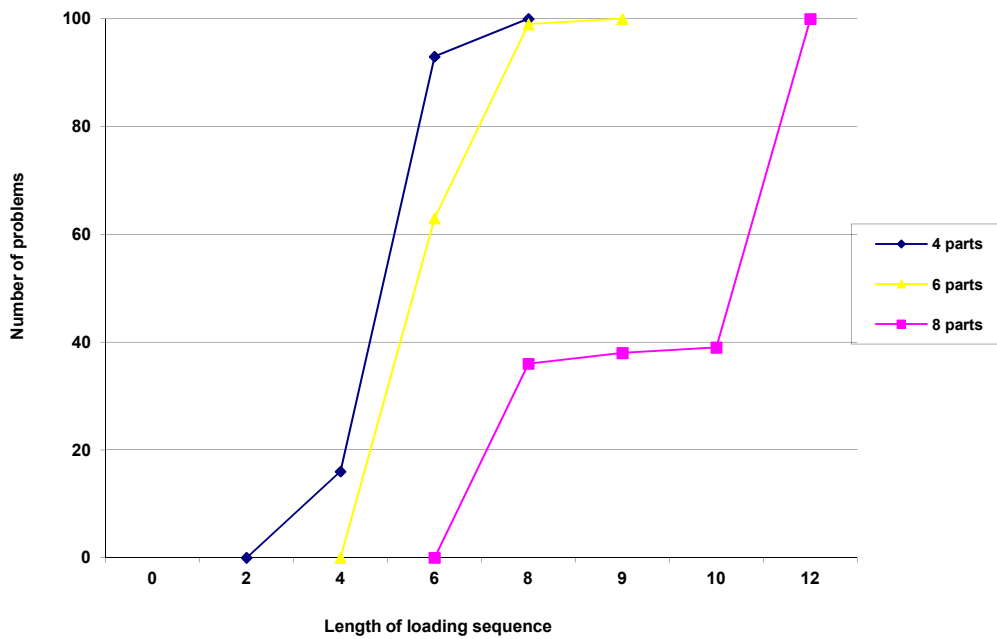

Fig. 11 Characteristics of test instances (loading sequence length)

Table 14 Test series with 4 parts

Parameters of problems	N	OSP	DM	DT	DP	SS	SM	LS
Minimal value	44	0.034	0.064	0.026	0	0.027	0	4
Maximal value	95	0.161	0.659	0.659	0.242	0.051	0.016	8
Average value	69	0.102	0.373	0.348	0.023	0.036	0.004	6

Table 15 Test series with 6 parts

Parameters of problems	N	OSP	DM	DT	DP	SS	SM	LS
Minimal value	89	0.029	0.003	0.002	0	0.024	0	6
Maximal value	159	0.111	0.462	0.462	0.205	0.031	0.008	9
Average value	124	0.08	0.229	0.198	0.028	0.027	0.002	7

Table 16 Test series with 8 parts

Parameters of problems	N	OSP	DM	DT	DP	SS	SM	LS
Minimal value	118	0.023	0.004	0.004	0	0.024	0	8
Maximal value	216	0.083	0.526	0.525	0.214	0.033	0.006	12
Average value	166	0.055	0.297	0.266	0.027	0.028	0.002	10

First, we compare the results of using model (1) – (38) with different combinations of constraints (20), (17) – (18), (17') – (18'), and (17'') for test instances with 4 parts.

By analyzing the results presented in Table 17, we can see the positive impact of the reduction of constraints (20).

Table 17 Impact of the transformation of constraints (20) on test series with 4 parts

Parameters	With inclusion constraints (20)	With reducing inclusion constraints (20)
Minimal time (sec)	1.32	0.76
Maximal time (sec)	601.074	609.27
Average time (sec)	38.238	33.912
Total time (sec)	3823.81	3391.17
Number of instances solved in shorter time	86	14

Then, we compare the effectiveness of modeling precedence constraints by (17) – (18), (17') – (18') and (17''). The summary results are presented in Table 18.

Table 18 Impact of modeling precedence constraints

Parameters	(17) – (18)	(17') – (18')	(17'')
Minimal time (sec)	0.76	1.071	0.665
Maximal time (sec)	609.27	544.771	3790.99
Average time (sec)	33.912	46.19	140.405
Total time (sec)	3391.17	4619.01	14040.5
Number of instances solved in shorter time	69	13	18

Finally, we present in Table 19 the summary results of solving 3 series of 100 test instances for 4, 6, and 8 parts with constraints (17) – (18) and the transformation of constraints (20). The maximal available time was set up to 2 hours (7200 sec). Feasible solutions were found for all test instances. However, only for 2 instances with 6 parts the optimality of found solutions was not proved while the number of such instances with 8 parts is equal to 11 with maximal gap 34.3 % (see Table 20). Number of solved problems in function of time is depicted in Figure 12. Parameters of easy and hard instances are presented in Table 20 and 21, respectively.

Table 19 Time solution of test instances

Parameters	4 parts	6 parts	8 parts
Minimal time (sec)	0.76	0.678	1.693
Maximal time (sec)	609.27	7200	7200
Average time (sec)	33.912	703.742	1767.59
Total time (sec)	3391.17	70374.2	174992
Number of solved instances	100	100	100
Number of instances with proven optimality	100	98	89

Table 20 Parameters of easy test instances

Parameters of problems	N	OSP	DM	DT	DP	SS	SM	LS	Time, sec
4 parts	63	0.093	0.598	0.591	0.001	0.037	0.002	4	0.76
6 parts	106	0.086	0.024	0.014	0.009	0.030	0.003	6	0.68
8 parts	159	0.065	0.162	0.161	0.000	0.024	0.000	8	1.69

Table 21 Parameters of hard test instances

Parameters of problems	N	OSP	DM	DT	DP	SS	SM	Time, sec	LS	Gap, %
4 parts	69	0.104	0.249	0.141	0.100	0.033	0.00	609.3	8	0
6 parts	118	0.094	0.335	0.291	0.037	0.028	0.000	7200	8	4.91
6 parts	159	0.065	0.335	0.291	0.037	0.028	0.000	7200	8	6.3
8 parts	176	0.061	0.291	0.276	0.009	0.027	0.001	7200	8	15.8
8 parts	148	0.043	0.232	0.155	0.062	0.031	0.001	7200	8	2.3
8 parts	185	0.079	0.264	0.226	0.026	0.026	0.000	7200	8	34.3
8 parts	185	0.079	0.260	0.220	0.032	0.026	0.001	7200	8	22.5
8 parts	175	0.073	0.277	0.220	0.046	0.028	0.001	7200	8	8.1
8 parts	177	0.073	0.230	0.221	0.006	0.025	0.002	7200	8	4.4
8 parts	170	0.072	0.185	0.169	0.010	0.027	0.001	7200	8	25.2
8 parts	132	0.053	0.316	0.254	0.046	0.032	0.001	7200	8	19.1
8 parts	180	0.060	0.219	0.046	0.168	0.028	0.000	7200	8	14.5
8 parts	179	0.060	0.378	0.295	0.075	0.026	0.000	7200	8	7.0

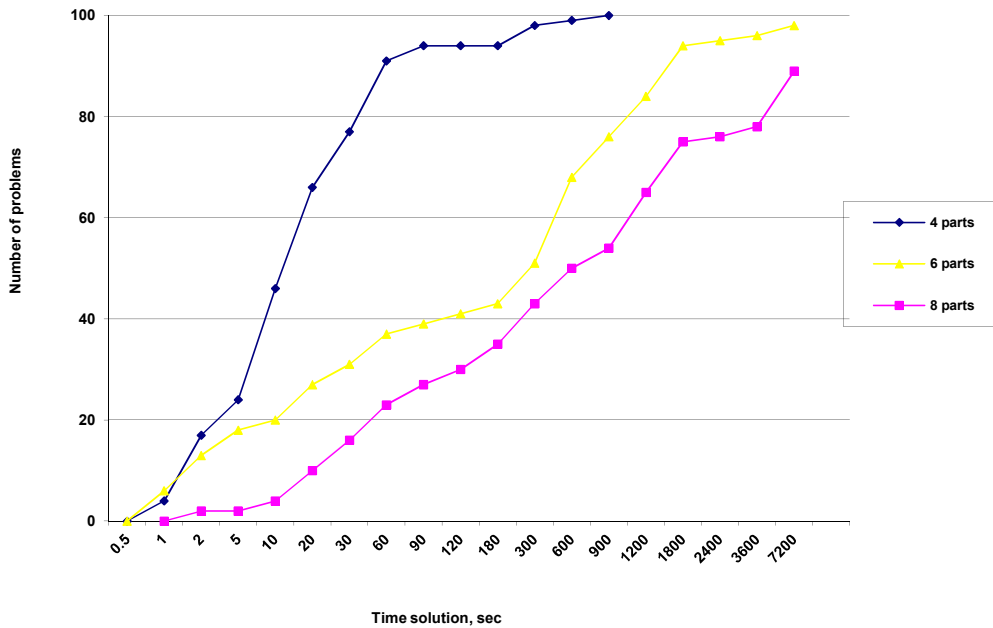

Fig. 12 Time solution diagram

6. CONCLUSION

This paper has proposed a joint formulation for process planning and system configuration for design of rotary transfer machines for a mixed-model production of different parts. The objective of suggested models is to minimize the total system cost. A mathematical formulation with several variants for this combinatorial optimization problem was developed and evaluated on an industrial case study. It was shown that the developed models could be successfully applied to the production cases with 6 different types of parts to be machined simultaneously at such a transfer machine. However, since the problem size is substantially increasing when the number of different types of parts is growing, as a consequence, it makes difficult to obtain optimal solutions for larger problem sizes. To address such problems efficiently within reasonable solution time, approximate methods have to be developed. Having such methods available will also allow envisaging the extension of the optimization problem by considering the sequence of the parts to be determined at the same time as the process planning and the system configuration.

REFERENCES

- Battaïa, O., Brissaud, D., Dolgui, A., Guschinsky, N. (2015) Variety-oriented design of rotary production systems. *CIRP Annals - Manufacturing Technology*, 64:1, 411-414.
- Battaïa, O., Dolgui, A., Guschinsky, N., and Levin, G. (2014a). Combinatorial techniques to optimally customize an automated production line with rotary transfer and turrets. *IIE Transactions*, 46 (9), 867-879.
- Battaïa, O., Dolgui, A., Guschinsky, N., Levin, G. (2014b) Integrated configurable equipment selection and line balancing for mass production with serial-parallel machining systems, *Engineering Optimisation*, 46:10, 1369-1388.
- Battaïa, O., Dolgui, A., Guschinsky, N., and Levin, G. (2012a). A decision support system for design of mass production machining lines composed of stations with rotary or mobile table. *Robotics and Computer-Integrated Manufacturing*, 28, 672-680.
- Battaïa, O., Dolgui, A., Guschinsky, N., and Levin, G. (2012b). Optimal design of machines processing pipeline parts. *International Journal of Advanced Manufacturing Technology*, 63, 963-973.

- Bensmaine, A., Dahane M., Benyoucef. L. (2014) A new heuristic for integrated process planning and scheduling in reconfigurable manufacturing systems, *International Journal of Production Research*, 52:12, 3583-3594.
- Chryssolouris, G., Chan, S., Suh, N.P. (1985) An integrated approach to process planning and scheduling, *CIRP Annals-Manufacturing Technology*, 34:1, 413–417.
- Copani, G., Leonesio, M., Molinari Tosatti, L., Pellegrinelli, S., Urgo, M., Valente, A. (2015) An integrated framework for combined designing dematerialised machine tools and production systems enabling flexibility-oriented business models, *International Journal of Computer Integrated Manufacturing*, 28:4, 353-363.
- Copani, G., Rosa, P. (2015) DEMAT: sustainability assessment of new flexibility-oriented business models in the machine tools industry, *International Journal of Computer Integrated Manufacturing*, 28:4, 408-417.
- Dolgui, A., Guschinsky, N., Levin, G. Proth, J.M. (2008) Optimisation of multi-position machines and transfer lines, *European Journal of Operational Research*, 185:3, 1375-1389.
- Dolgui, A., Guschinsky, N., Levin, G. (2009) Graph approach for optimal design of transfer machine with rotary table, *International Journal of Production Research*, 47:2, 321–341.
- Guschinskaya, O., Dolgui, A., Guschinsky, N., and Levin, G. (2009). Minimizing makespan for multi-spindle head machines with a mobile table. *Computers and Operations Research*, 36 (2), 344–357.
- Leonesio, M., Molinari Tosatti, L., Pellegrinelli, S., Valente, A. (2013) An integrated approach to support the joint design of machine tools and process planning. *CIRP Journal of Manufacturing Science and Technology*, 6, 181–186.
- Li, W. D., McMahon, C. A. (2007) A simulated annealing-based optimization approach for integrated process planning and scheduling, *International Journal of Computer Integrated Manufacturing*, 20:1, 80-95.
- Lv, S., Qiao, L. (2014) Process planning and scheduling integration with optimal rescheduling strategies, *International Journal of Computer Integrated Manufacturing*, 27:7, 638-655.
- Makssoud, F., O. Battaïa, A. Dolgui. An exact optimization approach for a Transfer Line Reconfiguration Problem. *International Journal of Advanced Manufacturing Technology*, 72 (2014) 717-727.
- Mohapatra, P., Kumar, N., Matta, A., Tiwari, M.K. (2014) A nested partitioning-based approach to integrate process planning and scheduling in flexible manufacturing environment, *International Journal of Computer Integrated Manufacturing*, DOI: 10.1080/0951192X.2014.961548
- Phanden R. K., Jain, A., Verma, R. (2011) Integration of process planning and scheduling: a state-of-the-art review, *International Journal of Computer Integrated Manufacturing*, 24:6, 517-534.
- Phanden R. K., Jain, A., Verma, R (2013) An approach for integration of process planning and scheduling, *International Journal of Computer Integrated Manufacturing*, 26:4, 284-302.
- Rabbani, M., Ziaieifar A., Manavizadeh N. (2014) Mixed-model assembly line balancing in assemble-to-order environment with considering express parallel line: problem definition and solution procedure, *International Journal of Computer Integrated Manufacturing*, 27:7, 690-706.
- Szadkowski J. (1971) An approach to machining process optimization, *International Journal of Production Research*, 9:3, 371-376.
- Terkaj, W., Tolio, T., Valente, A. (2010) A stochastic programming approach to support the machine tool builder in designing focused flexibility manufacturing systems (ffmss), *International Journal of Manufacturing Research*, 5, 199-229.
- Terkaj, W., Tolio, T., Valente, A. Focused flexibility in production systems, H. ElMaraghy (Ed.), *Changeable and reconfigurable manufacturing systems*, Springer, Berlin (2009), pp. 47-66.

- Tolio, T., Urgo, M., (2013) Design of flexible transfer lines: A case-based reconfiguration cost assessment, *Journal of Manufacturing Systems*, 32:2, 325-334.
- Xu, X., Wang, L., Newman S.T. (2011) Computer-aided process planning – A critical review of recent developments and future trends, *International Journal of Computer Integrated Manufacturing*, 24:1, 1–31.
- Yin, R., Cao, H., Li H., Sutherland J.W. (2014) A process planning method for reduced carbon emissions, *International Journal of Computer Integrated Manufacturing*, 27:12, 1175-1186.