



HAL
open science

Octal Games on Graphs: The game 0.33 on subdivided stars and bistars

Laurent Beaudou, Pierre Coupechoux, Antoine Dailly, Sylvain Gravier, Julien Moncel, Aline Parreau, Eric Sopena

► To cite this version:

Laurent Beaudou, Pierre Coupechoux, Antoine Dailly, Sylvain Gravier, Julien Moncel, et al.. Octal Games on Graphs: The game 0.33 on subdivided stars and bistars. 2016. hal-01418153v1

HAL Id: hal-01418153

<https://hal.science/hal-01418153v1>

Preprint submitted on 16 Dec 2016 (v1), last revised 5 Jun 2018 (v3)

HAL is a multi-disciplinary open access archive for the deposit and dissemination of scientific research documents, whether they are published or not. The documents may come from teaching and research institutions in France or abroad, or from public or private research centers.

L'archive ouverte pluridisciplinaire **HAL**, est destinée au dépôt et à la diffusion de documents scientifiques de niveau recherche, publiés ou non, émanant des établissements d'enseignement et de recherche français ou étrangers, des laboratoires publics ou privés.

Octal Games on Graphs: The game 0.33 on subdivided stars and bistars [☆]

Laurent Beaudou^a, Pierre Coupechoux^d, Antoine Dailly^{e,*}, Sylvain Gravier^f, Julien Moncel^{b,c}, Aline Parreau^e, Éric Sopena^{g,h}

^aLIMOS, 1 rue de la Chebarde, 63178 Aubière CEDEX, France.

^bLAAS-CNRS, Université de Toulouse, CNRS, Université Toulouse 1 Capitole - IUT Rodez, Toulouse, France

^cFédération de Recherche Maths à Modeler, Institut Fourier, 100 rue des Maths, BP 74, 38402 Saint-Martin d'Hères Cedex, France

^dLAAS-CNRS, Université de Toulouse, CNRS, INSA, Toulouse, France.

^eUniv Lyon, Université Lyon 1, LIRIS UMR CNRS 5205, F-69621, Lyon, France.

^fCNRS/Université Grenoble-Alpes, Institut Fourier/SFR Maths à Modeler, 100 rue des Maths - BP 74, 38402 Saint Martin d'Hères, France.

^gUniv. Bordeaux, LaBRI, UMR5800, F-33400 Talence, France.

^hCNRS, LaBRI, UMR5800, F-33400 Talence, France.

Abstract

Octal games are a well-defined family of two-player games played on heaps of counters, in which the players remove alternately a certain number of counters from a heap, sometimes being allowed to split a heap into two nonempty heaps, until no counter can be removed anymore.

We extend the definition of octal games to play them on graphs: heaps are replaced by connected components and counters by vertices. Thus, an octal game on a path P_n is equivalent to playing the same octal game on a heap of n counters.

We study one of the simplest octal games, called 0.33, in which the players can remove one vertex or two adjacent vertices without disconnecting the graph. We study this game on trees and give a complete resolution of this game on subdivided stars and bistars.

Keywords: Combinatorial Games; Octal Games; Subtraction Games; Graphs

1. Introduction

Combinatorial games are finite two-player games without chance, with perfect information and such that the last move alone determines which player wins the game. Since the information is perfect and the game finite, there is always a winning strategy for one of the players. A formal definition of combinatorial games and basic results will be given in Section 2. For more details, the interested reader can refer to [1], [2] or [3].

A well-known family of combinatorial games are *subtraction games*, which are played with a heap of counters. A subtraction game is defined by a list of positive integers L and is denoted by $Sub(L)$. A player is allowed to remove k counters from the heap if $k \in L$. The first player unable to remove an allowed number of counters from the heap loses the game. For example, consider the game $Sub(\{1, 2\})$. In this game, both players take turns removing one or two counters from the heap, until the heap is empty. If the initial number of counters is a multiple of 3, then the second player has a winning strategy: by playing in such a way that the first player always gets a multiple of 3, he will take the last counter and win the game.

A natural generalization of subtraction games is to allow the players to split a heap in two nonempty heaps after having removed counters. This defines a much larger class of games, called *octal games* [1]. An octal game is represented by an octal code which entirely defines its rules. As an example, $Sub(\{1, 2\})$ is

[☆]This work has been supported by the ANR-14-CE25-0006 project of the French National Research Agency.

*Corresponding author

defined as **0.33**. A precise definition will be given in Section 2. Octal games have been extensively studied. One of the most important question [4] is the periodicity of these games. Indeed, it seems that all finite octal games have a periodic behaviour in the following sense: the set of initial numbers of counters for which the first player has a winning strategy is ultimately periodic. This is true for all subtraction games and for all finite octal games for which the study has been completed [5, 1].

Octal games can also be played by placing counters on a row. Heaps are constituted by consecutive counters and only consecutive counters can be removed. According to this representation, it seems natural to play octal games on more complex structures like graphs. A position of the game is a graph and players remove vertices that induce a connected component which correspond to consecutive counters. The idea to extend the notion of octal games to graphs was already suggested in [6]. However, to our knowledge, this idea has not been further developed. With our definition, playing the generalization of an octal game on a path is the same as playing the original octal game. In the special case of subtraction games, players have to leave the graph connected. As an example, playing **0.33** on a graph consists in removing one vertex or two adjacent vertices from the graph without disconnecting it.

This extension of octal games is in line with several take-away games on graphs as ARC KAYLES [7] and GRIM [8]. However, it does not describe some other deletion games, such as the vertex and edge versions of the game GEOGRAPHY [7, 9], vertex and edge deletion games with parity rules, considered in [10] and [11], or scoring deletion games such as Le Pic'arete [12].

We will first give in Section 2 basic definitions of combinatorial games theory as well as a formal definition of octal games on graphs. We then focus on the game **0.33** which is one of the simplest octal games, and to its study on trees. We first study subdivided stars in Section 3. We prove that paths can be reduced modulo 3 which leads to a complete resolution, in contrast with the related studies on subdivided stars of NODE KAYLES [6] and ARC KAYLES [13]. In Section 4, we extend our results to subdivided bistars (i.e. trees with at most two vertices of degree at least 3) using an operator similar to the sum of games. Unfortunately, these results cannot be extended to all trees and even not to caterpillars. In a forthcoming paper [14], some of our results are generalized to other subtraction games on subdivided stars.

2. Definitions

2.1. Basics of Combinatorial Game Theory

Combinatorial games [1] are two-player games such that:

1. The two players play alternately.
2. There is no chance.
3. The game is finite (there is finitely many positions and no position can be encountered twice during the game).
4. The information is perfect.
5. The last move alone determines the winner.

In what is called *normal* play, the player who plays the last move wins the game. In what is called *misère* play, the player who plays the last move loses the game. *Impartial games* are combinatorial games where at each turn the moves are the same for both players. Hence the only distinction between both players is who plays the first move. In this paper, we will only consider impartial games in normal play.

Positions in impartial games have exactly two possible *outcomes*: either the first player has a winning strategy, or the second player has a winning strategy. If a game position falls into the first category, it is an *N-position* (for *N*ext player wins); otherwise, it is a *P-position* (for *P*revious player wins).

From a given position J of the game, the different positions that can be reached by playing a move from J are the *options* of J , and the set of options of J is denoted $\text{opt}(J)$. If we know the outcomes of the positions in $\text{opt}(J)$ we can deduce the outcome of J , using the following proposition:

Observation 1. Let J be a position of an impartial combinatorial game in normal play:

- If $\text{opt}(J) = \emptyset$, then the position J is a \mathcal{P} -position.
- If there exists a \mathcal{P} -position J' in $\text{opt}(J)$, then the position J is an \mathcal{N} -position: a winning move consists in playing from J to J' .
- If all the options of J are \mathcal{N} -positions, then the position J is a \mathcal{P} -position.

Every position J of a combinatorial game can be viewed as a combinatorial game with J as the initial position. We therefore often consider positions as games. Given two games J_1 and J_2 , their *disjoint sum*, noted $J_1 + J_2$, is defined as the game where, at their turn, each player plays a legal move on either J_1 or J_2 . Once J_1 (resp. J_2) is finished, the two players play exclusively on J_2 (resp. J_1), until it is over. The player who plays the last move wins the game. If J_1 is a \mathcal{P} -position, then $J_1 + J_2$ has the same outcome as J_2 : the winning player of J_2 applies his strategy on J_2 , and if the other player plays on J_1 then he applies the winning strategy on J_1 . In order to study the disjoint sum of two \mathcal{N} -positions, we define the *equivalence* of two games J_1 and J_2 : $J_1 \equiv J_2$ if and only if $J_1 + J_2$ is a \mathcal{P} -position. According to this relation, one can attribute to a game a value corresponding to its equivalence class and called the *Grundy value*. The Grundy value of a game position P for a game J , denoted by $\mathcal{G}_J(P)$, can be computed from the Grundy value of its options using the following formula:

$$\mathcal{G}_J(P) = \text{mex}(\mathcal{G}_J(P') | P' \in \text{opt}(P))$$

where, for any set of integers S , $\text{mex}(S)$ is the smallest nonnegative integer not in S . In particular, P is a \mathcal{P} -position if and only if $\mathcal{G}_J(P) = 0$. Note that this is consistent with Observation 1. When the context is clear, we will denote $\mathcal{G}_J(P)$ as $\mathcal{G}(P)$.

A fundamental result of Combinatorial Game Theory is the Sprague-Grundy Theorem that gives the Grundy values of the sum of games:

Theorem 2 (Sprague-Grundy Theorem [15]). Let J_1 and J_2 be two game positions. Then $\mathcal{G}(J_1 + J_2) = \mathcal{G}(J_1) \oplus \mathcal{G}(J_2)$, where \oplus , called the *nim-sum*, is the bitwise XOR applied to the two values written in base 2.

2.2. Octal games

A well-known family of impartial games is the family of *octal games*, which are played on heaps of counters. On their turn, each player removes some counters from one heap and may also divide the remaining counters of the heap into two nonempty heaps. The rules of an octal game are encoded according to an octal number as follows:

Definition 3 (Octal games [1]). Let $u_1, u_2, \dots, u_n, \dots$ be nonnegative integers such that for all i , $u_i \leq 7$. In the octal game $\mathbf{0.u_1u_2\dots u_n\dots}$, a player can remove i counters from a heap if and only if $u_i \neq 0$.

Moreover, if we write u_i as $u_i = b_1^i + 2 * b_2^i + 4 * b_3^i$ with $b_j^i \in \{0, 1\}$, then, the player can, when removing i counters:

1. empty the heap if and only if $b_1^i = 1$;
2. leave one nonempty heap if and only if $b_2^i = 1$;
3. split the remaining heap in two nonempty heaps if and only if $b_3^i = 1$.

An octal game is *finite* if it has a finite number of non-zero values. In this case, we stop the code at the last non-zero u_i 's.

As an example, $\mathbf{u_i = 3}$ means that a player can remove i counters from a heap without splitting it. Octal games with only $\mathbf{0}$ and $\mathbf{3}$ in their code correspond to *subtraction games* since the heap is never divided. In particular, the game $\mathbf{0.33}$ is the game where one can remove one or two counters from the heap. A value $\mathbf{u_i = 7}$ means that one can remove i counters from a heap, possibly dividing the heap in two heaps whereas

$\mathbf{u}_i = \mathbf{6}$ means that one can remove i counters from a heap except if the heap has exactly i counters, and possibly divide it into two heaps.

To study an octal game, it suffices to consider it on a single heap. Indeed, using Theorem 2, one can obtain the Grundy value of any octal game by computing the nim-sum of its components. The *Grundy sequence* of an octal game is the sequence of the Grundy values of the game on a heap of n counters with $n = 0, 1, 2, \dots$. For example, the Grundy sequence of $\mathbf{0.33}$ is $0, 1, 2, 0, 1, 2, \dots$ since the Grundy value of the game $\mathbf{0.33}$ on a heap of size n is $n \bmod 3$.

The Grundy sequence of $\mathbf{0.33}$ is periodic and one can prove that this is the case for all finite subtraction games [1]. Actually, all the octal games which have been completely studied have an ultimately periodic Grundy sequence¹. This led to the following conjecture, proposed by Guy:

Conjecture 4 (Guy's conjecture [4]). *All finite octal games have ultimately periodic Grundy sequences.*

2.3. Octal games on graphs

A natural question is whether this periodicity can be extended to more complex structures. A relevant structure is graphs. Indeed, as explained in the introduction, octal games are generally played with counters on a row. Considering a row of counters as a path and replacing the notion of consecutive counters by connected components, we get the following definition of octal games on graphs:

Definition 5 (Octal game on graphs). *Let $u_1, u_2, \dots, u_n, \dots$ be nonnegative integers such that for all i , $u_i \leq 7$. Let G be a graph and H a connected component of G .*

In the octal game $\mathbf{0.u_1u_2\dots u_n\dots}$ played on G , a player can remove a set X_i of i vertices of H only if $u_i \neq 0$ and X_i induces a connected graph.

*Moreover, if we write u_i as $u_i = b_1^i + 2 * b_2^i + 4 * b_3^i$, with $b_j^i \in \{0, 1\}$, then:*

1. *the player can empty H (i.e. $X_i = H$) if and only if $b_1 = 1$;*
2. *the player can leave H connected with at least one vertex (i.e. $H \setminus \{X_i\}$ is non empty and connected) if and only if $b_2 = 1$*
3. *the player can disconnect H if and only if $b_3 = 1$.*

If G is a path, then the game is equivalent to the corresponding standard octal game of Definition 3. We now consider several examples. The game $\mathbf{0.33}$ on a connected graph corresponds to the game where one can take one vertex or two adjacent vertices without disconnecting it. The game $\mathbf{0.07}$ corresponds to the game where one can remove any two adjacent vertices of the graph. That is exactly the well known game ARC KAYLES [7]. Recently, Adams *et al.* [8] studied the game GRIM that is exactly $\mathbf{0.6}$ on some graphs (players are allowed to remove any vertex of the graph, except if it is an isolated vertex). A scoring version of $\mathbf{0.6}$ is also currently studied [16]. Hence our definition is relevant with existing work. Note that the well-known game NODE KAYLES cannot be seen as such an octal game even if on a path it is equivalent to $\mathbf{0.137}$. Indeed, in NODES KAYLES, when four vertices can be removed, they cannot induce a P_4 . This cannot match our definition.

Remark 6. *We ask for the i removed vertices to form a connected component for two reasons. First, in traditional octal games, the counters are generally taken consecutively. The second reason is that if we remove this condition, then all subtraction games on graphs will be trivial. Indeed, it is always possible to remove a vertex of a connected graph and keep the graph connected. Therefore it is also always possible to remove i vertices of the graph without disconnecting it if the vertices do not need to induce a connected graph. Thus playing a subtraction game on a graph would be equivalent to playing the same game on a path with the same number of vertices and we lose the interest of considering more complex structures. With our definition, subtraction games on graphs are not so straightforward.*

¹For an up-to-date table of octal games, see <http://wwwhomes.uni-bielefeld.de/achim/octal.html>

In the rest of this paper, we focus on one octal game, namely **0.33**, for which we provide a detailed analysis on subdivided stars and bistars: by proving lemmas about reductibility of paths, we provide an equivalence between families of stars and bistars which allows us to determine their Grundy value.

3. A study of 0.33 game on subdivided stars

The subdivided star $S_{\ell_1, \dots, \ell_k}$ is the graph composed of a central vertex connected to k paths of length ℓ_1, \dots, ℓ_k . Figure 1 shows an example of such a graph. The subdivided star S_0 has no chain attached to its central vertex, so that it is isomorphic to P_1 .

Note that the subdivided star S_{ℓ_1} is isomorphic to P_{ℓ_1+1} and that the subdivided star S_{ℓ_1, ℓ_2} is isomorphic to $P_{\ell_1+\ell_2+1}$. For reasons of clarity, the notation as paths will be used whenever applicable.

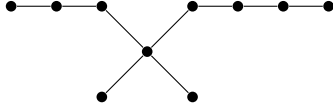

Figure 1: The subdivided star $S_{1,1,3,4}$.

In the **0.33** game played on a graph, players can remove a vertex or two adjacent vertices from the graph, provided that they do not disconnect the graph. Figure 2 shows the moves that are available for the first player on a subdivided star. Note that in every figure describing moves, the original position will be boxed.

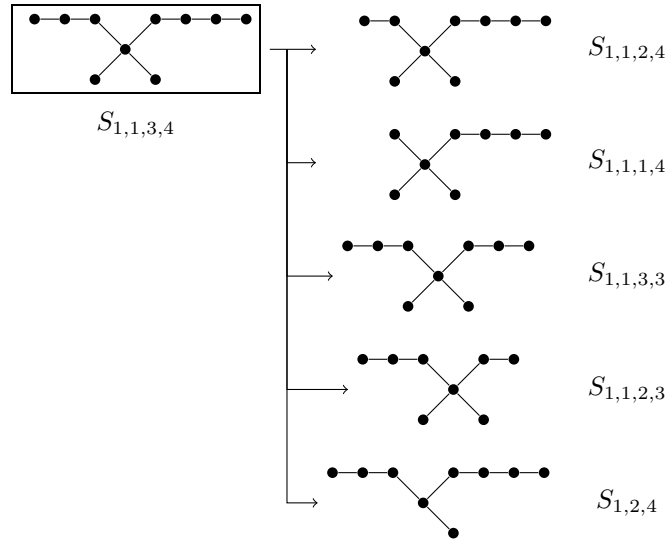

Figure 2: The available moves for the first player in the **0.33** game played on the subdivided star $S_{1,1,3,4}$.

The **0.33** game on paths and cycles has the same nim-sequence as the **0.33** game on heaps of counters: for any $n \geq 0$, $\mathcal{G}(P_n) = \mathcal{G}(C_n) = n \bmod 3$. In this section, we will prove a similar result for subdivided stars: every path can be reduced to its length modulo 3 without changing the Grundy value.

Theorem 7. For all ℓ_1, \dots, ℓ_k , we have $\mathcal{G}(S_{\ell_1, \dots, \ell_k}) = \mathcal{G}(S_{\ell_1 \bmod 3, \dots, \ell_k \bmod 3})$.

To prove this theorem, it suffices to prove that a P_3 can be added to the central vertex or appended to a leaf of a subdivided star without changing the Grundy value. This will follow from a series of lemmas.

Lemma 8. Let S be a subdivided star, with $S \neq P_1$ and $S \neq P_2$. If S is an \mathcal{N} -position, then there is a winning move which does not involve taking the central vertex.

Proof. Let S be a subdivided star ($S \neq P_1$ and $S \neq P_2$).

First, suppose that S is not a chain, i.e. $S = S_{\ell_1, \ell_2, \ell_3}$, with $\ell_1, \ell_2, \ell_3 > 0$. Then, no winning move may involve taking the central vertex, as such a move would be illegal.

Now, let S be a chain of length n . Since S is an \mathcal{N} -position, we can assume that $n \geq 4$. If a winning move involves taking the central vertex, then it can be taking one or two vertices including the central vertex. Hence the central vertex is the first or the second vertex of the chain and this winning move can be replicated on the other end of the chain without taking the central vertex, since $n \geq 4$. \square

Lemma 9. *Let $\ell \geq 0$ and $S = S_{1,1,\ell}$. We have $\mathcal{G}(S) = |V(S)| \bmod 3 = \ell \bmod 3$.*

Proof. We use induction on ℓ . First, suppose that one can remove the central vertex of S . Thus, we are in one of the following cases:

- $\ell = 0$. In this case, $S = P_3$, and we are done.
- $\ell = 1$. In this case, the only available move is to remove a leaf, leaving only P_3 . Thus, $\mathcal{G}(S) = \text{mex}(\mathcal{G}(P_3)) = \text{mex}(0) = 1$.

Now, if $\ell > 1$, then one cannot remove the central vertex of S . In this case, three moves are available from S :

- Removing one of the two leaves, leaving $P_{\ell+2}$ which has $\ell + 2 \bmod 3$ as Grundy value;
- Removing one vertex from the chain of length ℓ , leaving a star which has $\ell + 2 \bmod 3$ as Grundy value by induction hypothesis;
- Removing two vertices from the chain of length ℓ , leaving a star which has $\ell + 1 \bmod 3$ as Grundy value by induction hypothesis.

Thus, we have $\mathcal{G}(S) = \text{mex}(\ell + 1 \bmod 3, \ell + 2 \bmod 3) = \ell \bmod 3$. \square

Lemma 10. *A P_3 can be appended to any leaf or to the central vertex of a subdivided star without changing its Grundy value.*

Proof. Let S be a subdivided star, and S' be the subdivided star obtained by appending a P_3 to any leaf or to the central vertex of S . We show that $S + S'$ is a \mathcal{P} -position by proving that the second player can always play to a \mathcal{P} -position following the first player's move. The proof is by induction on $|V(S)|$.

First, we consider the cases where the first player can remove the central vertex of S :

- If S is empty (resp. $S = P_1, S = P_2$), then $S' = P_3$ (resp. $S' = P_4, S' = P_5$), and thus $\mathcal{G}(S) = \mathcal{G}(S')$;
- If $S = P_3$, then either $S' = P_6$ and we are done, or $S' = S_{1,1,3}$ and the result follows from Lemma 9.
- If $S = P_m$ with $m \geq 4$, then, as said in the proof of Lemma 8, the second player will always be able to replicate the first player's move on S' , by playing the symmetrical move. By induction hypothesis, the new position will be a \mathcal{P} -position.

Now, we consider the cases where the first player cannot remove the central vertex of S :

- If the first player takes one vertex (resp. two vertices) from the new chain in S' , then the second player takes two vertices (resp. one vertex) from it, leaving $S + S$ which is a \mathcal{P} -position.
- If the first player plays elsewhere on S' , the second player answers by playing the same move on S . By induction hypothesis, the new position will be a \mathcal{P} -position.
- If $S \neq P_m$, then the first player cannot remove the central vertex. In this case, for every first player's move on S , the second player can replicate it on S' , allowing us to invoke the induction hypothesis.

\square

Theorem 7 then directly follows from Lemma 10. Hence, all paths of length $3p$ can be reduced to 0, all paths of length $3p + 1$ can be reduced to 1, and all paths of length $3p + 2$ can be reduced to 2. If we want to know the Grundy value of a given subdivided star, it then suffices to study the Grundy values of the subdivided stars with paths of length 1 and 2 attached to its central vertex.

We are able to build a table of positions and their options: the rows stand for the number of paths attached to the central vertex, and the columns stand for the number of paths of length 2. Figure 3 shows the first six rows of this table (the first two rows correspond to the empty graph and the subdivided star reduced to its central vertex, respectively):

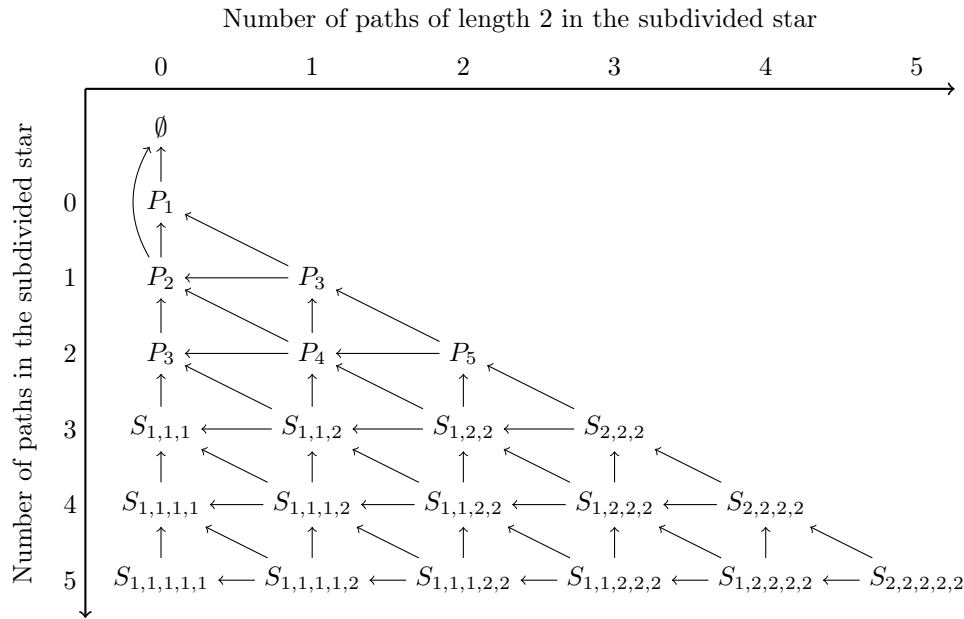

Figure 3: The first six rows of the table of positions and their options.

Since the empty graph has a Grundy value of 0, we can deduce the Grundy value of every star by proceeding inductively from the top lines:

Theorem 11. *Figure 4 shows the table of the Grundy values of subdivided stars after reduction of their paths modulo 3; rows stand for the number of paths attached to the central vertex and columns for the number of paths of length 2 in the star.*

Except for the four first lines, the lines with an odd number of paths are of the form 1203(12)* whereas the even lines are of the form 0312(03)*. Moreover, except for the four first columns, the columns with an even number of paths of length 2 are of the form (01)* whereas the columns with an odd number of paths of length 2 are of the form (23)*.

4. The game 0.33 on subdivided bistars

Let S_1 and S_2 be two subdivided stars. The subdivided bistar $S_1 \overset{m}{\bullet} S_2$ is the graph constructed by joining the central vertices of S_1 and S_2 by a path of m edges. If $m = 0$, then the subdivided bistar is a subdivided star. Likewise, if $m = 1$ and $S_1 = \emptyset$ (resp. $S_2 = \emptyset$), then the subdivided bistar is the subdivided star S_2 (resp. S_1). Figure 5) shows an example of a subdivided bistar.

For the sake of convenience, we will denote $S_1 \overset{1}{\bullet} S_2$ by $S_1 \bullet S_2$.

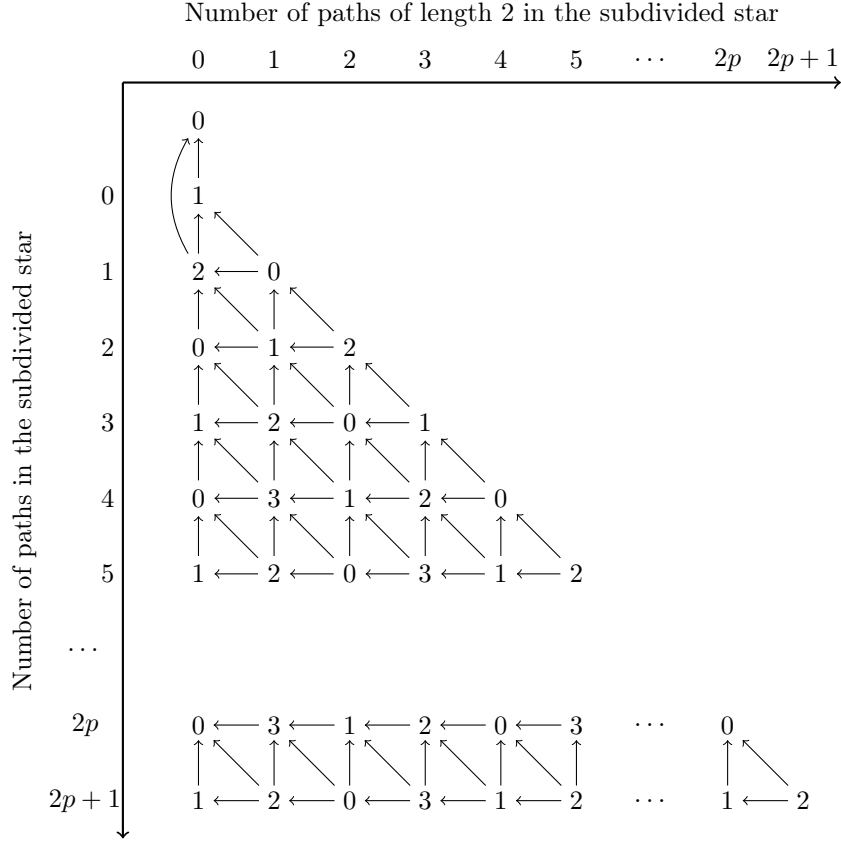

Figure 4: First six rows, and rows $2p$ and $2p + 1$, of the table of Grundy values for the subdivided stars.

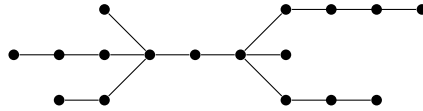

Figure 5: The subdivided bistar $S_{1,2,3} \bullet^2 S_{1,3,4}$.

We notice that playing the **0.33** game on a subdivided bistar is similar to playing the **0.33** game on the two subdivided stars composing it with an "adjustment" depending on the length of the path linking the two stars, except for some small cases where one of the stars can be emptied so that one can play on the middle path.

This section is divided in two parts. In the first part, we will prove that every path in a subdivided bistar can be reduced to its length modulo 3 without changing the Grundy value:

Theorem 12. For all $\ell_1, \dots, \ell_k, \ell_{k+1}, \dots, \ell_l, m$, we have: $\mathcal{G}(S_1 \bullet^m S_2) = \mathcal{G}(S'_1 \bullet^{m \bmod 3} S'_2)$, where $S_1 = S_{\ell_1, \dots, \ell_k}$, $S_2 = S_{\ell_{k+1}, \dots, \ell_l}$, $S'_1 = S_{\ell_1 \bmod 3, \dots, \ell_k \bmod 3}$ and $S'_2 = S_{\ell_{k+1} \bmod 3, \dots, \ell_l \bmod 3}$.

The second part will focus on computing the Grundy value of a subdivided bistar, depending on the Grundy values of each of its two subdivided stars.

4.1. Reducing the paths of a subdivided bistar

In this section, we prove Theorem 12. We begin by proving the result on the middle path, before proving it on the paths of the two subdivided stars composing the bistar.

Note that we allow the length of the middle path to reach 0. Thus, if a subdivided bistar has a middle path of $3k$ edges, then it can be reduced to a subdivided star without changing its Grundy value.

Lemma 13. *The path linking the two stars of a subdivided bistar can be reduced to its length modulo 3 without changing the Grundy value of the bistar.*

Proof. It is enough to prove that adding three edges to the path does not change the Grundy value of the subdivided bistar.

Let S_1 and S_2 be two subdivided stars. Let $B = S_1 \bullet^m \bullet S_2$ and $B' = S_1 \bullet^{m+3} \bullet S_2$. We show that $B + B'$ is a \mathcal{P} -position by proving that for every first player's move, the second player always has an answer leading to a \mathcal{P} -position. We use induction on the size of B .

The cases where the first player can play on the middle path are when one of the two stars is either empty or reduced to a single vertex. In this case, B and B' are subdivided stars, and the result follows from Lemma 10.

Assume now that both S_1 and S_2 have at least two vertices. Hence, the first player is unable to play on the middle path and can play either on S_1 or S_2 . The second player will replicate the same move on the other subdivided bistar. By induction hypothesis, the result follows. \square

In order to prove that the paths of the stars can be reduced, we need a few technical lemmas.

Lemma 14. *Let S be a subdivided star, and $B = S \bullet \bullet S_{1,1}$. We have $\mathcal{G}(S) = \mathcal{G}(B)$.*

Proof. We show that $S + B$ is a \mathcal{P} -position by proving that for every first player's move, the second player always has an answer leading to a \mathcal{P} -position. We use induction on the size of S .

The cases where the first player can remove the central vertex of S are:

- S is empty, thus $B = P_3$, which is a \mathcal{P} -position;
- S is reduced to a vertex, thus $B = S_{1,1,1}$. We know by Lemma 9 that $\mathcal{G}(B) = 1 = \mathcal{G}(S)$;
- $S = P_2$, thus $B = S_{1,1,2}$. Considering Figure 4, we get $\mathcal{G}(B) = 2 = \mathcal{G}(S)$;
- $S = P_3$, and in that case, either $S = S_{1,1}$ or $S = S_2$:
 1. $B = S_{1,1} \bullet \bullet S_{1,1}$. B is a \mathcal{P} -position: the first player has only one available move, and from the resulting graph the second player can play to P_3 which is a \mathcal{P} -position. Both B and S being \mathcal{P} -positions, we have $\mathcal{G}(B) = \mathcal{G}(S)$.
 2. $B = S_{1,1,3}$. By Theorem 7, $\mathcal{G}(S) = \mathcal{G}(B)$.
- $S = P_m$ with $m \geq 4$. By Lemma 8, the second player will always be able to replicate the first player's move on B , by playing the symmetrical move. By induction hypothesis, the new position is a \mathcal{P} -position.

Figure 6 depicts the cases where the first player does not take the central vertex of S , and completes the proof.

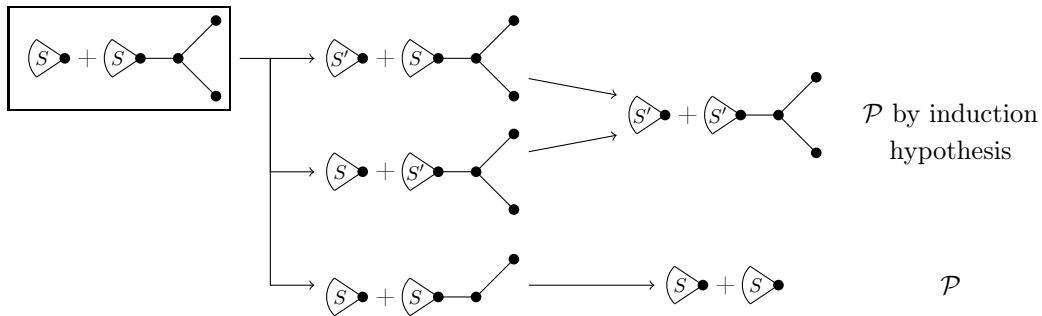

Figure 6: The inductive part of the proof of Lemma 14

□

Let S be a subdivided star, we denote $S \bullet \rightarrow \emptyset$ by $S \bullet \rightarrow$. We then have:

Lemma 15. *Let S be a subdivided star. We have $\mathcal{G}(S \bullet \rightarrow) = \mathcal{G}(S \bullet \rightarrow S_{1,1})$.*

Proof. We denote $B = S \bullet \rightarrow S_{1,1}$. We show that $S + B$ is a \mathcal{P} -position by proving that for every first player's move, the second player always has an answer leading to a \mathcal{P} -position. We use induction on the size of S .

The cases where the first player can remove either the central vertex of S or both the central vertex of S and the vertex from the middle path of $S \bullet \rightarrow$ are:

- S is empty, thus $B = S_{1,1,1}$. We know by Lemma 9 that $\mathcal{G}(B) = 1 = \mathcal{G}(S \bullet \rightarrow)$;
- S is a single vertex, thus $B = S_{1,1,2}$. Considering Figure 4, we get $\mathcal{G}(B) = 2 = \mathcal{G}(S \bullet \rightarrow)$;
- $S = P_2$, thus $B = S_{1,1,3}$ which by Lemma 10 has the same Grundy value as $S_{1,1}$, *i.e.* as P_3 . Thus, $\mathcal{G}(B) = \mathcal{G}(S \bullet \rightarrow)$;
- $S \bullet \rightarrow = S_{1,1,1}$, thus $B = 1, 1 \bullet \rightarrow 1, 1$. Considering Table 4, we get $\mathcal{G}(S \bullet \rightarrow) = 1$. It is easy to see that $\mathcal{G}(B) = 1$, since only one move is available for the first player (removing one leaf vertex), which leaves $S_{1,1,3}$ which is a \mathcal{P} -position. Thus $\mathcal{G}(S \bullet \rightarrow) = \mathcal{G}(B)$.
- $S = P_m$ with $m \geq 4$. By the same argument as in the proof of Lemma 8, the second player will always be able to replicate the first player's move on B , by playing the symmetrical move. By induction hypothesis, the new position is a \mathcal{P} -position.

Figure 7 depicts the cases where the first player does take neither the central vertex of S nor both the central vertex of S and the vertex from the middle path of $S \bullet \rightarrow$, and completes the proof.

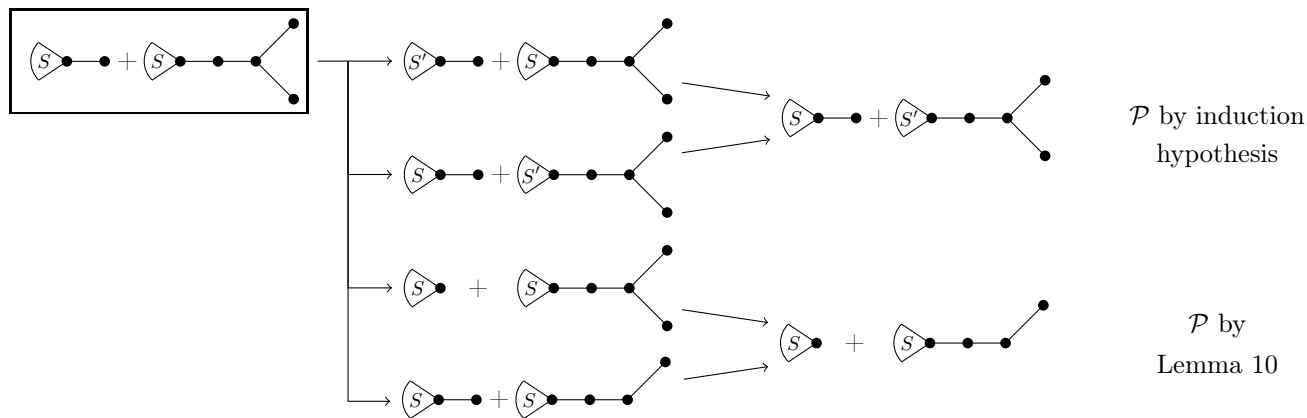

Figure 7: The inductive part of the proof of Lemma 15.

□

We are now ready to prove that the paths of the two subdivided stars of a bistar can be reduced:

Lemma 16. *In a subdivided bistar, the paths of each star can be reduced to their length modulo 3 without changing the Grundy value.*

Proof. Thanks to Lemma 13, we only have to prove the result on the bistars with a middle path of length 1 or 2.

Let S_1 and S_2 be two subdivided stars, $B = S_1 \bullet^i \bullet S_2$ with $i \in \{1, 2\}$, and B' the subdivided bistar obtained by appending a P_3 to a leaf or to the central vertex of (without loss of generality) S_2 . We prove by induction on $|V(B)|$ that $\mathcal{G}(B) = \mathcal{G}(B')$.

First, we consider the cases where the first player can remove the central vertex of S_2 :

- If S_2 is empty (resp. a single vertex), then B is a subdivided star, and the result holds by Lemma 10;
- If S_2 is a chain, and the P_3 is appended to its central vertex, then replicating the first player's move will always be possible and lead to a \mathcal{P} -position by induction hypothesis (by using the argument of the proof of Lemma 8), except if $B = S_1 \bullet \bullet P_2$ (resp. $B = S_1 \bullet^2 \bullet P_2$). In those cases, if the first player empties S_2 on B , then the second player is unable to replicate the move on B' . The strategy is then to take two vertices from the new chain. By Lemma 14 (resp. Lemma 15), we have $\mathcal{G}(B) = \mathcal{G}(B')$.

Now, we consider the cases where the first player cannot take the central vertex of S_2 :

- If the first player takes one vertex (resp. two vertices) from the new chain on B' , then the second player answers by taking two vertices (resp. one vertex) from it, leaving $B + B$ which is a \mathcal{P} -position.
- Otherwise, the first player plays either on S_1 or on S_2 in either of the two bistars. Note that the first player cannot remove the central vertex of S_2 , since S_2 is not a chain. The second player answers by replicating his move on the other bistar, which is always a legal move, allowing us to invoke the induction hypothesis.

□

Theorem 12 then follows from Lemmas 13 and 16. As in the subdivided stars section, we are left with a limited number of bistars to study. The next section presents the study of the Grundy value of a subdivided bistar depending on the Grundy values of its subdivided stars.

4.2. Computing the Grundy value of a subdivided bistar

We try to express the Grundy value of a subdivided star in function of the Grundy values of its two stars.

By Lemma 13, it is enough to consider bistars whose middle path has length either 1 or 2. We consider these two cases separately.

4.2.1. When the middle path is of length 1

Playing on a subdivided bistar with a middle path of length 1 is almost equivalent as playing in the disjoint union of the two subdivided stars, except for small cases when some moves are not available in the bistar. We will see in what follows that except for some small cases, the Grundy value of the bistar is indeed the nim-sum of the Grundy values of the two stars.

We refine the equivalence relation \equiv for subdivided stars as follows. Let S_1 and S_2 be two subdivided stars. We say that S_1 and S_2 are \sim_1 -equivalent, denoted $S_1 \sim_1 S_2$, if and only if for any subdivided star S , $S_1 \bullet \bullet S \equiv S_2 \bullet \bullet S$.

Note that the Grundy value of a bistar $S \bullet \bullet S'$ only depends of the equivalence class under \sim_1 of S and S' . The equivalence \sim_1 is a refinement of \equiv since taking $S = \emptyset$ we have $S_1 \equiv S_2$.

By Lemma 14, we already know that $P_3 \sim_1 \emptyset$, and thus $S_2 \sim_1 \emptyset$ and $S_{1,1} \sim_1 \emptyset$.

We will prove that there are actually eight equivalence classes for \sim_1 :

- $\mathcal{C}_1^* = \{P_1, S_{2,1}, S_{2,2,2}\}$ (these stars have Grundy value 1);
- $\mathcal{C}_2^* = \{P_2, S_{2,2}\}$ (these stars have Grundy value 2);
- \mathcal{C}_2^\square : subdivided stars S such that $\mathcal{G}(S) = 2$ and S contains one or three paths of length 2;

- \mathcal{C}_3^\square : subdivided stars S such that $\mathcal{G}(S) = 3$ and S contains one or three paths of length 2;
- For $i \in \{0, 1, 2, 3\}$, \mathcal{C}_i : subdivided stars S with $\mathcal{G}(S) = i$ and S is not in a previous class.

Theorem 17. *The equivalence classes for \sim_1 are exactly the sets $\mathcal{C}_0, \mathcal{C}_1, \mathcal{C}_1^*, \mathcal{C}_2, \mathcal{C}_2^*, \mathcal{C}_2^\square, \mathcal{C}_3$ and \mathcal{C}_3^\square . Moreover, Table 1 describes how the Grundy value of $S \bullet \rightarrow S'$ can be computed depending on the equivalence class of S and S' .*

	\mathcal{C}_0	\mathcal{C}_1	\mathcal{C}_1^*	\mathcal{C}_2	\mathcal{C}_2^*	\mathcal{C}_2^\square	\mathcal{C}_3	\mathcal{C}_3^\square
\mathcal{C}_0	\oplus	\oplus	\oplus	\oplus	\oplus	\oplus	\oplus	\oplus
\mathcal{C}_1	\oplus	\oplus	\oplus	\oplus	\oplus	\oplus	\oplus	\oplus
\mathcal{C}_1^*	\oplus	\oplus	2	\oplus	0	\oplus	\oplus	\oplus
\mathcal{C}_2	\oplus	\oplus	\oplus	\oplus	\oplus	\oplus	\oplus	\oplus
\mathcal{C}_2^*	\oplus	\oplus	0	\oplus	1	1	\oplus	0
\mathcal{C}_2^\square	\oplus	\oplus	\oplus	\oplus	1	\oplus	\oplus	\oplus
\mathcal{C}_3	\oplus	\oplus	\oplus	\oplus	\oplus	\oplus	\oplus	\oplus
\mathcal{C}_3^\square	\oplus	\oplus	\oplus	\oplus	0	\oplus	\oplus	\oplus

Table 1: Computing the Grundy value of $S \bullet \rightarrow S'$ depending on the equivalence class of S and S' .

We will need some technical lemmas before proving the theorem:

Lemma 18. *We have:*

1. $P_1 \sim_1 S_{2,1}$
2. $P_2 \sim_1 S_{2,2}$
3. $S_{1,1} \sim_1 S_{2,2,1}$
4. $S_{2,1} \sim_1 S_{2,2,2}$.

Therefore, any two elements in \mathcal{C}_1^* (resp. \mathcal{C}_2^*) are \sim_1 -equivalent.

Proof. Each of these equivalences will be proved in the same way: for an equivalence $S_1 \sim_1 S_2$, we prove that for every subdivided star S , $\mathcal{G}(S \bullet \rightarrow S_1) = \mathcal{G}(S \bullet \rightarrow S_2)$. We will use induction on $|S|$. The base cases will be when $|S| \in \{0, 1, 2\}$, that is to say when the first player is able to take the central vertex of S . Each of these cases corresponds to a subdivided star, whose Grundy value is given in Figure 4. In the inductive part, we need to prove that for every move on $S \bullet \rightarrow S_1 + S \bullet \rightarrow S_2$ by the first player, the second player has a move leading to a \mathcal{P} -position. In every case, if the first player plays on S , then the second player can replicate the move, allowing us to invoke the induction hypothesis. Thus, we will only consider the moves on S_1 or S_2 in each case.

Case 1 : $P_1 \sim_1 S_{2,1}$

Figure 8 shows the possible moves on S_1 or S_2 , and the answer leading to a \mathcal{P} -position.

Case 2 : $P_2 \sim_1 S_{2,2}$

Figure 9 shows the possible moves on S_1 or S_2 , and the answer leading to a \mathcal{P} -position.

Case 3 : $S_{1,1} \sim_1 S_{2,2,1}$

Figure 10 shows the possible moves on S_1 or S_2 , and the answer leading to a \mathcal{P} -position.

Case 4 : $S_{2,1} \sim_1 S_{2,2,2}$

Figure 11 shows the possible moves on S_1 or S_2 , and the answer leading to a \mathcal{P} -position.

□

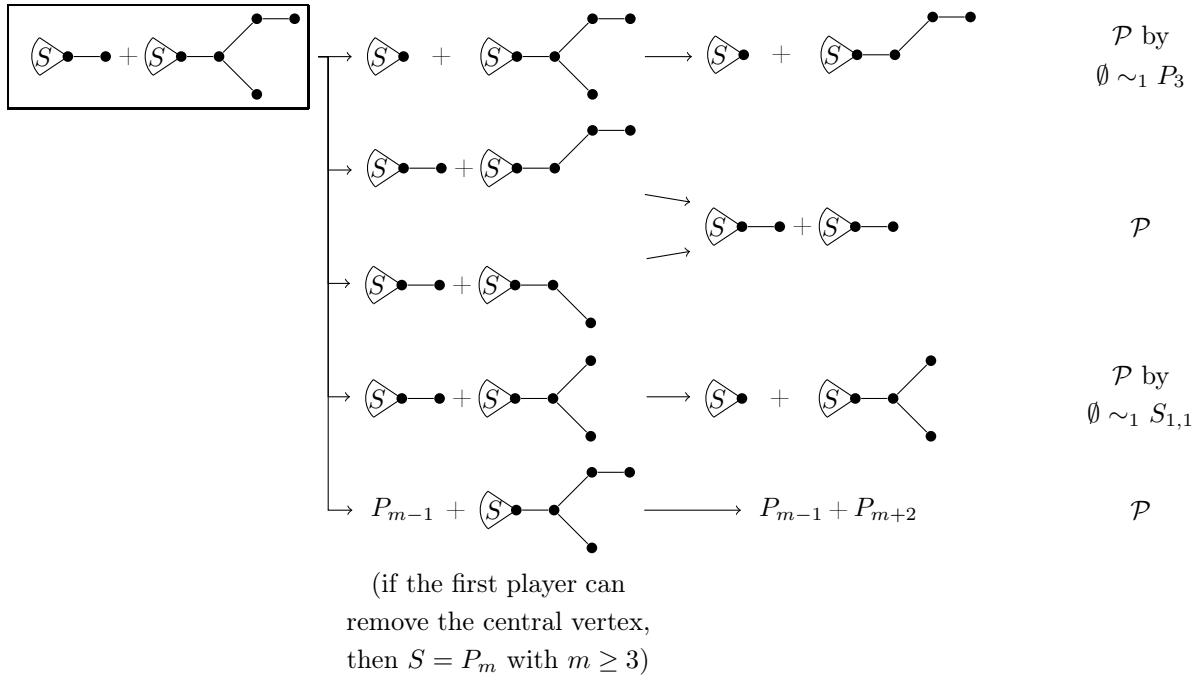

Figure 8: The inductive part of the proof that $P_1 \sim_1 S_{2,1}$.

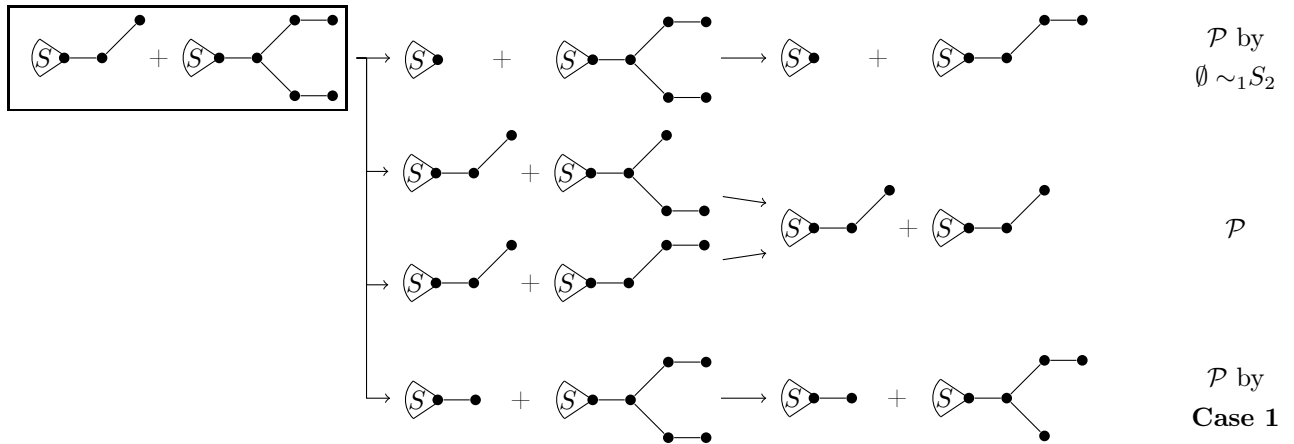

Figure 9: The inductive part of the proof that $P_2 \sim_1 S_{2,2}$.

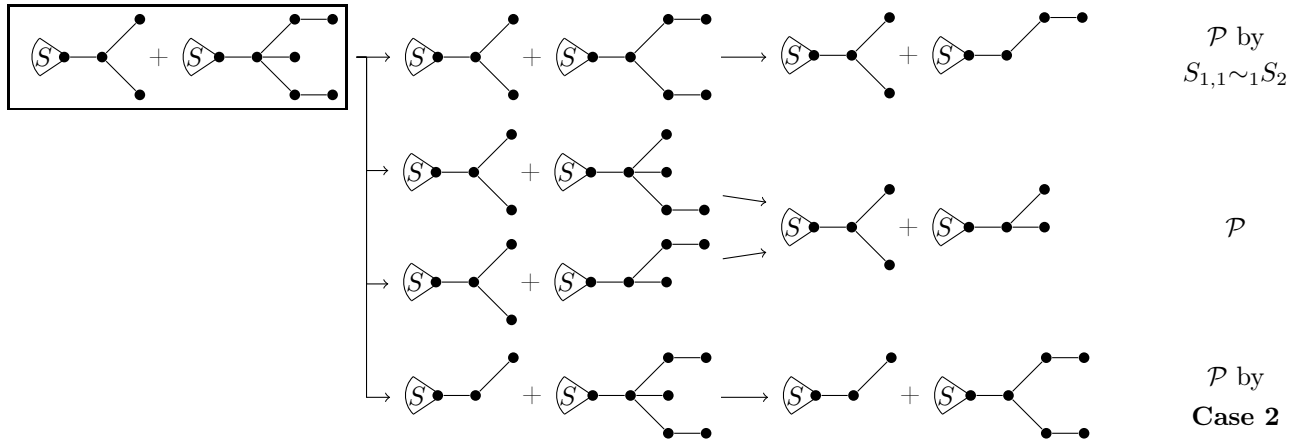

Figure 10: The inductive part of the proof that $S_{1,1} \sim_1 S_{2,2,1}$.

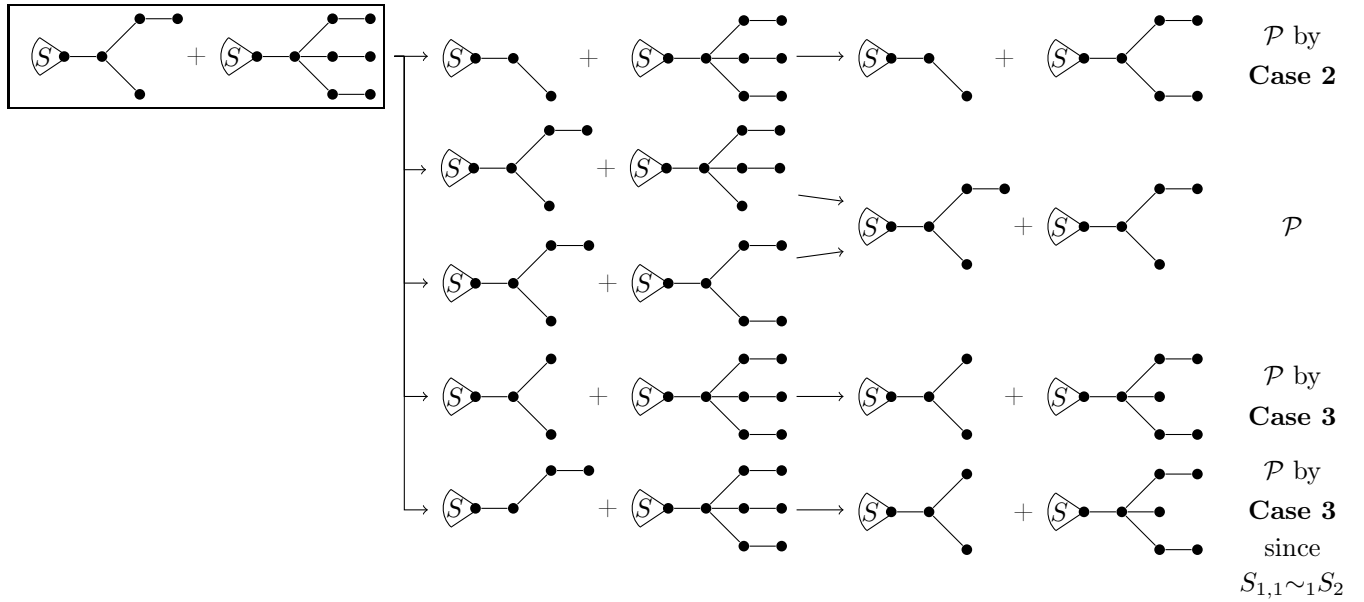

Figure 11: The inductive part of the proof that $S_{2,1} \sim_1 S_{2,2,2}$.

Lemma 19. *Let S be a subdivided star not belonging to $\mathcal{C}_1^* \cup \mathcal{C}_2^*$. Then $S_{1,1,1} \bullet \bullet S \equiv P_1 \bullet \bullet S$.*

Proof. We use induction on $|S|$. The base cases are the subdivided stars having an option in $\mathcal{C}_1^* \cup \mathcal{C}_2^*$:

1. $S = \emptyset$. In this case, $\mathcal{G}(S_{1,1,1} \bullet \bullet S) = \mathcal{G}(S_{1,1,1}) = 1 = \mathcal{G}(P_1) = \mathcal{G}(P_1 \bullet \bullet S)$.
2. $S = S_{1,1}$. In this case, $\mathcal{G}(S_{1,1,1} \bullet \bullet S) = \mathcal{G}(S_{1,1,1})$ (by Lemma 18) $= \mathcal{G}(P_1 \bullet \bullet S)$.
3. $S = S_{2,1,1}$. In this case, $\mathcal{G}(S_{1,1,1} \bullet \bullet S) = 3 = \mathcal{G}(S_{2,1,1,1}) = \mathcal{G}(P_1 \bullet \bullet S)$.
4. $S = S_{2,2,1}$. In this case, $\mathcal{G}(S_{1,1,1} \bullet \bullet S) = \mathcal{G}(S_{1,1,1} \bullet \bullet S_{1,1})$ (by Lemma 18) $= 1 = \mathcal{G}(S_{2,2,1,1}) = \mathcal{G}(P_1 \bullet \bullet S)$.
5. $S = S_{2,2,2,1}$. In this case, $\mathcal{G}(S_{1,1,1} \bullet \bullet S) = 3 = \mathcal{G}(S_{2,2,2,1,1}) = \mathcal{G}(P_1 \bullet \bullet S)$.
6. $S = S_{2,2,2,2}$. In this case, $\mathcal{G}(S_{1,1,1} \bullet \bullet S) = 1 = \mathcal{G}(S_{2,2,2,2,1}) = \mathcal{G}(P_1 \bullet \bullet S)$.

Although tedious, all these values can be computed by considering the Grundy values of the sets $\text{opt}(S_{1,1,1} \bullet \bullet S)$ and $\text{opt}(P_1 \bullet \bullet S)$.

We now prove that if S is a subdivided star not belonging to $\mathcal{C}_1^* \cup \mathcal{C}_2^*$, then $S_{1,1,1} \bullet \bullet S \equiv P_1 \bullet \bullet S$. We note that the first player can neither empty S nor take its central vertex. We show that for every first player's move on $S_{1,1,1} \bullet \bullet S + P_1 \bullet \bullet S$, the second player can always move to a \mathcal{P} -position. If the first player plays from S to S' , then $S' \notin \mathcal{C}_1^* \cup \mathcal{C}_2^*$, thus if the second player replicates the move, we can invoke the induction hypothesis. Figure 12 shows the end of the inductive proof.

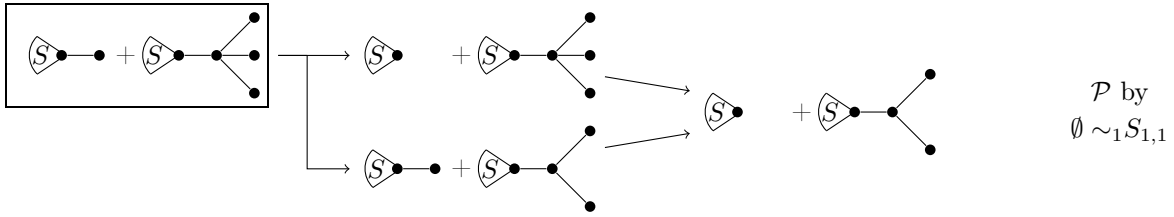

Figure 12: The inductive part of the proof for Lemma 19.

□

Proof of Theorem 17. We prove by induction on the total number of vertices of S_1 and S_2 that if S_1 and S_2 are in the same set $\mathcal{C}_0, \mathcal{C}_1, \mathcal{C}_1^*, \mathcal{C}_2, \mathcal{C}_2^*, \mathcal{C}_2^\square, \mathcal{C}_3$ or \mathcal{C}_3^\square , then they are \sim_1 -equivalent.

By Lemma 18, this is true if S_1 and S_2 are in \mathcal{C}_1^* or in \mathcal{C}_2^* . It is also true if $S_1, S_2 = \{\emptyset, S_{1,1}\}$ by Lemma 14 or if $S_1, S_2 = \{\emptyset, P_3\}$ since it is the same that adding a P_3 to the central vertex of a subdivided star.

Furthermore, we can check that the lines of Table 1 for \mathcal{C}_1^* and \mathcal{C}_2^* are correct. To check that, it suffices to prove it for one representant of \mathcal{C}_1^* (P_1) and one representant of \mathcal{C}_2^* (P_2). Adding P_1 to a subdivided star corresponds to going down in the table of Figure 4: there are always a 1 under a 0, a 2 under an element of \mathcal{C}_1^* and a 0 under the other 1, a 2 under a 3 and a 3 under a 2 except for \mathcal{C}_2^* where the value under 2 is 0. This corresponds exactly to the line of \mathcal{C}_1^* of Table 1. Similarly, adding P_2 corresponds to going down right in the table (in diagonal) and one can check that the Grundy values are correct. Thus we are done.

Suppose now that S_1 and S_2 belong to the same set \mathcal{C} , with $\mathcal{C} \neq \mathcal{C}_1^*$ and $\mathcal{C} \neq \mathcal{C}_2^*$. Thus both S_1 and S_2 are either empty or not a chain. We prove by induction on the size of S that $S_1 \bullet \bullet S \equiv S_2 \bullet \bullet S$ for any subdivided star S . This is true if $S = \emptyset$ (since $\mathcal{G}(S_1) = \mathcal{G}(S_2)$) or if $S \in \mathcal{C}_1^* \cup \mathcal{C}_2^*$ (by the previous paragraph). Hence we can assume that $S \notin \mathcal{C}_1^* \cup \mathcal{C}_2^*$ and S is not a chain. We will prove that $S_1 \bullet \bullet S + S_2 \bullet \bullet S$ is a \mathcal{P} -position. The first player cannot play both in S_1 and S nor both in S_2 and S since S is not a chain. If the first player plays in S , leading to S' in one of the two games, the first player cannot take the central vertex (since S is not a chain). Hence the second player can reply to $S_1 \bullet \bullet S' + S_2 \bullet \bullet S'$ which is a \mathcal{P} -position by induction hypothesis. Otherwise, the first player plays in S_1 or in S_2 . By symmetry, we can assume that the first player plays in S_1 , leading to a game $S_1' \bullet \bullet S + S_2 \bullet \bullet S$. We have to find an answer from that game to a \mathcal{P} -position.

- (i) If there is a move from S'_1 to S''_1 with S''_1 in the same set than S_1 then the second player plays to $S''_1 \bullet \bullet S + S_2 \bullet \bullet S$ (this is always possible since if the move from S'_1 to S''_1 is taking the central vertex and S''_1 is not empty, it means that S'_1 is a chain which is not P_3 , nor P_4 , a contradiction). By induction, $S''_1 \bullet \bullet S + S_2 \bullet \bullet S$ is a \mathcal{P} -position.
- (ii) If there is a move from S_2 to S'_2 with S'_1 and S'_2 in the same set, then the second player plays to $S'_1 \bullet \bullet S + S'_2 \bullet \bullet S$ (again, this is always possible since S_2 is not a chain), which is a \mathcal{P} -position by induction hypothesis.

Assume that none of these two cases occurs. If $\mathcal{G}(S_1) = 3$ then we are always in the case (ii). If $\mathcal{G}(S_1) = 0$ then we are always in the case (i). Hence we have $\mathcal{G}(S_1) \in \{1, 2\}$. If $\mathcal{G}(S_1) = 1$, then $S_1, S_2 \in \mathcal{C}_1$. If $\mathcal{G}(S'_1) = 0$ then we are in the case (ii). Otherwise, $\mathcal{G}(S'_1) > 1$, and there is always a move from S'_1 to $S''_1 \in \mathcal{C}_1$ and we are in the case (ii). Hence $\mathcal{G}(S_1) = 2$. If $\mathcal{G}(S'_1) = 0$ or if $S'_1 \in \mathcal{C}_1$, then we are in the case (ii). If $\mathcal{G}(S'_1) = 3$, we are in the case (i). Hence the only remaining case is $S'_1 \in \mathcal{C}_1^*$. Then there is a move from S_2 to S'_2 with $S'_2 \in \mathcal{C}_1$. By induction, $S'_2 \bullet \bullet S \equiv S_{1,1,1} \bullet \bullet S$ (indeed, the number of vertices in S_1 and S_2 is strictly greater than the number of vertices in S'_2 and $S_{1,1,1}$ since S_1 has at least five vertices). By Lemma 19, $S_{1,1,1} \bullet \bullet S \equiv P_1 \bullet \bullet S \equiv S'_1 \bullet \bullet S$ (since $S \notin \mathcal{C}_1^* \cup \mathcal{C}_2^*$). Thus $S'_1 \bullet \bullet S \equiv S'_2 \bullet \bullet S$ and $S'_1 \bullet \bullet S + S'_2 \bullet \bullet S$ is a \mathcal{P} -position.

To compute Table 1, it is enough to consider one representant of each class, for instance $\emptyset, P_1, P_2, S_{1,1,1}, S_{2,1,1}, S_{2,1,1,1}, S_{2,2,2,2,2}, S_{2,2,2,2,2,1}$, respectively, and compute their Grundy value. \square

4.2.2. When the middle path is of length 2

The situation in that case will be more complicated than in the previous case. We similarly define an equivalence relation \sim_2 . Let S_1 and S_2 be two subdivided stars. We say that S_1 and S_2 are \sim_2 -equivalent, denoted $S_1 \sim_2 S_2$, if and only if for any subdivided star S , $S_1 \bullet \bullet S \equiv S_2 \bullet \bullet S$.

By Lemma 15, we already know that $P_3 \sim_2 \emptyset$, and thus $S_2 \sim_2 \emptyset$ and $S_{1,1} \sim_2 \emptyset$.

We will prove that there are exactly ten equivalence classes for \sim_2 :

- \mathcal{D}_0^* : subdivided stars S such that $\mathcal{G}(S) = 0$ and S contains zero or two paths of length 2;
- $\mathcal{D}_1^* = \{P_1, S_{2,1}, S_{2,2,2}\}$ (these stars have Grundy value 1);
- \mathcal{D}_1^\square : subdivided stars S such that $\mathcal{G}(S) = 1$, S contains zero or two paths of length 2 and $S \neq P_1$;
- $\mathcal{D}_2^* = \{P_2, S_{2,2}\}$ (these stars have Grundy value 2);
- \mathcal{D}_2^\square : subdivided stars S such that $\mathcal{G}(S) = 2$ and S contains one or three paths of length 2;
- \mathcal{D}_3^\square : subdivided stars S such that $\mathcal{G}(S) = 3$ and S contains one or three paths of length 2;
- For $i \in \{0, 1, 2, 3\}$, \mathcal{D}_i : subdivided stars S with $\mathcal{G}(S) = i$ and S is not in a previous class.

Theorem 20. *The equivalence classes for \sim_2 are exactly the sets $\mathcal{D}_0, \mathcal{D}_0^*, \mathcal{D}_1, \mathcal{D}_1^*, \mathcal{D}_1^\square, \mathcal{D}_2, \mathcal{D}_2^*, \mathcal{D}_2^\square, \mathcal{D}_3$ and \mathcal{D}_3^\square . Moreover, Table 2 describes how the Grundy value of $S \bullet \bullet S'$ can be computed depending on the equivalence class of S and S' .*

We can notice that when the two subdivided stars are of sufficiently large order, they are in the classes $\mathcal{D}_0, \mathcal{D}_1, \mathcal{D}_2, \mathcal{D}_3$, and the Grundy value of the bistar is given by the nim-sum of their Grundy values. For most of the smallest subdivided stars, it is the nim-sum of the two stars and of 1 that gives the Grundy value of the bistar.

The following lemma gives the validity of \mathcal{D}_1^* and \mathcal{D}_2^* . Its proof is not included, since it is similar to the proof of Lemma 18.

Lemma 21. *We have:*

1. $P_1 \sim_2 S_{2,1}$

	\mathcal{D}_0	\mathcal{D}_0^*	\mathcal{D}_1	\mathcal{D}_1^*	\mathcal{D}_1^\square	\mathcal{D}_2	\mathcal{D}_2^*	\mathcal{D}_2^\square	\mathcal{D}_3	\mathcal{D}_3^\square
\mathcal{D}_0	\oplus	\oplus_1	\oplus	2	\oplus_1	\oplus	0	\oplus_1	\oplus	\oplus_1
\mathcal{D}_0^*	\oplus_1	\oplus_1	\oplus_1	2	\oplus_1	\oplus_1	0	\oplus_1	\oplus_1	\oplus_1
\mathcal{D}_1	\oplus	\oplus_1	\oplus	3	\oplus_1	\oplus	1	\oplus_1	\oplus	\oplus_1
\mathcal{D}_1^*	2	2	3	0	3	0	1	1	1	0
\mathcal{D}_1^\square	\oplus_1	\oplus_1	\oplus_1	3	\oplus_1	\oplus_1	1	\oplus_1	\oplus_1	\oplus_1
\mathcal{D}_2	\oplus	\oplus_1	\oplus	0	\oplus_1	\oplus	2	\oplus_1	\oplus	\oplus_1
\mathcal{D}_2^*	0	0	1	1	1	2	2	2	3	3
\mathcal{D}_2^\square	\oplus_1	\oplus_1	\oplus_1	1	\oplus_1	\oplus_1	2	0	\oplus_1	1
\mathcal{D}_3	\oplus	\oplus_1	\oplus	1	\oplus_1	\oplus	3	\oplus_1	\oplus	\oplus_1
\mathcal{D}_3^\square	\oplus_1	\oplus_1	\oplus_1	0	\oplus_1	\oplus_1	3	1	\oplus_1	0

Table 2: Computing the Grundy value of $S^{\bullet^2 \bullet} S'$ depending on the equivalence class of S and S' . Recall that \oplus denotes the nim-sum. Moreover, $x \oplus_1 y$ stands for $x \oplus y \oplus 1$.

2. $P_2 \sim_2 S_{2,2}$
3. $S_{1,1} \sim_2 S_{2,2,1}$
4. $S_{2,1} \sim_2 S_{2,2,2}$.

Therefore, any two elements in \mathcal{D}_1^* (resp. \mathcal{D}_2^*) are \sim_2 -equivalent.

We can now prove Theorem 20:

Proof of Theorem 20. Rather than proving the validity of equivalence classes and then deducing the table, we prove by induction on the total number of vertices in S_1 and S_2 that the Grundy value of $S_1^{\bullet^2 \bullet} S_2$ is given by Table 2.

We can check that the lines of \mathcal{D}_1^* and \mathcal{D}_2^* in Table 2 are correct: it suffices to prove it for one representant for \mathcal{D}_1^* (P_1) and for \mathcal{D}_2^* (P_2). This is possible since if $S_1, S_2 \in \mathcal{D}_1^*, \mathcal{D}_2^*$, then they are \sim_2 -equivalent by Lemma 21. For any subdivided star S , $S^{\bullet^2 \bullet} P_1$ is S with a path of length 2 added to its central vertex. Thus, we only need to look at the Figure 4 below and right of every class. We can check that if $\mathcal{G}(S) = 0$ then $\mathcal{G}(S^{\bullet^2 \bullet} P_1) = 2$, if $S \in \mathcal{D}_1^*, \mathcal{D}_2, \mathcal{D}_3^\square$ then $\mathcal{G}(S^{\bullet^2 \bullet} P_1) = 0$, if $S \in \mathcal{D}_1, \mathcal{D}_1^\square$ then $\mathcal{G}(S^{\bullet^2 \bullet} P_1) = 3$, if $S \in \mathcal{D}_2^*, \mathcal{D}_2^\square, \mathcal{D}_3$ then $\mathcal{G}(S^{\bullet^2 \bullet} P_1) = 1$. For any subdivided star S , $S^{\bullet^2 \bullet} P_2$ is S with a path of length 3 added to its central vertex. Thus, $\mathcal{G}(S^{\bullet^2 \bullet} P_2) = \mathcal{G}(S)$.

Now we study the Grundy value of $S_1^{\bullet^2 \bullet} S_2$ depending on their classes. We can suppose that $S_1, S_2 \notin \mathcal{D}_1^*, \mathcal{D}_2^*$, and that neither S_1 nor S_2 are $S_{1,1}$ or P_3 (since, by Lemma 15, $S_{1,2} \sim_2 \emptyset$; and $P_3 \sim_2 \emptyset$ by Lemma 10). We can find the options of S_1 and S_2 thanks to Figure 3. None of the options of S_1 and S_2 involves taking their central vertex. We can verify Table 2 by computing the Grundy value of $S_1^{\bullet^2 \bullet} S_2$ in function of the Grundy values of their options, by using the induction hypothesis:

$$\mathcal{G}(S_1^{\bullet^2 \bullet} S_2) = \text{mex}(\mathcal{G}(S_1^{\bullet^2 \bullet} S_2'), \mathcal{G}(S_1^{\bullet^2 \bullet} S_2'') | S_1' \text{ option of } S_1, S_2' \text{ option of } S_2)$$

In order to prove that the equivalence classes are correct, we need to check that the Grundy value of $S_1^{\bullet^2 \bullet} S_2$ does not change with the classes of the options of S_1 and S_2 . Indeed, two subdivided stars belonging to the same class can have different options.

We will prove two cases, the other ones being similar.

Case 1: $S_1 \in \mathcal{D}_1$ and $S_2 \in \mathcal{D}_3$

In this case, S_1 always has three different options, but these options are not the same depending on S_1 . S_1 always has an option in \mathcal{D}_0 , and it can have two options either in \mathcal{D}_2^\square and \mathcal{D}_3^\square or in \mathcal{D}_2 and \mathcal{D}_3 . S_2 has three options, which are in $\mathcal{D}_1, \mathcal{D}_2$ and \mathcal{D}_3 .

These possible options of S_1 and S_2 are shown on Figure 13. Left are the possible options of S_1 , and right are the possible options of S_2 . The notation $\mathcal{D}_i \bullet^2 \bullet \mathcal{D}_j$ expresses the fact that the two subdivided stars S'_1 and S_2 (resp. S_1 and S'_2) are in the classes \mathcal{D}_i and \mathcal{D}_j , and that the subdivided bistar is smaller than $S_1 \bullet^2 \bullet S_2$, allowing us to invoke the induction hypothesis.

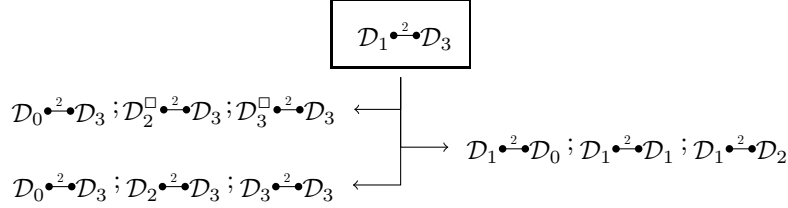

Figure 13: The possible options of $S_1 \bullet^2 \bullet S_2$ when $S_1 \in \mathcal{C}_1$ and $S_2 \in \mathcal{C}_3$.

Now, we can compute the Grundy value of $S_1 \bullet^2 \bullet S_2$. First, we compute it in the case where the options of S_1 are in \mathcal{D}_2^\square and \mathcal{D}_3^\square :

$$\begin{aligned} \mathcal{G}(S_1 \bullet^2 \bullet S_2) &= \text{mex}(\mathcal{G}(\mathcal{D}_0 \bullet^2 \bullet \mathcal{D}_3), \mathcal{G}(\mathcal{D}_2^\square \bullet^2 \bullet \mathcal{D}_3), \mathcal{G}(\mathcal{D}_3^\square \bullet^2 \bullet \mathcal{D}_3), \mathcal{G}(\mathcal{D}_1 \bullet^2 \bullet \mathcal{D}_0), \mathcal{G}(\mathcal{D}_1 \bullet^2 \bullet \mathcal{D}_1), \mathcal{G}(\mathcal{D}_1 \bullet^2 \bullet \mathcal{D}_2)) \\ &= \text{mex}(3, 0, 1, 1, 0, 3) \text{ (by induction hypothesis)} \\ &= 2 \end{aligned}$$

Now, we compute it in the case where the options of S_1 are in \mathcal{D}_2 and \mathcal{D}_3 :

$$\begin{aligned} \mathcal{G}(S_1 \bullet^2 \bullet S_2) &= \text{mex}(\mathcal{G}(\mathcal{D}_0 \bullet^2 \bullet \mathcal{D}_3), \mathcal{G}(\mathcal{D}_2 \bullet^2 \bullet \mathcal{D}_3), \mathcal{G}(\mathcal{D}_3 \bullet^2 \bullet \mathcal{D}_3), \mathcal{G}(\mathcal{D}_1 \bullet^2 \bullet \mathcal{D}_0), \mathcal{G}(\mathcal{D}_1 \bullet^2 \bullet \mathcal{D}_1), \mathcal{G}(\mathcal{D}_1 \bullet^2 \bullet \mathcal{D}_2)) \\ &= \text{mex}(3, 1, 0, 1, 0, 3) \text{ (by induction hypothesis)} \\ &= 2 \end{aligned}$$

The Grundy value being the same in both cases, we can conclude that $\mathcal{G}(S_1 \bullet^2 \bullet S_2) = 2$.

Case 2: $S_1 \in \mathcal{D}_0$ and $S_2 \in \mathcal{D}_2$

In this case, the possible options of S_1 and S_2 are given by Figure 14. Left are the options of S_1 , and right are the options of S_2 . Below each possible bistar is the Grundy value of the bistar, thanks to the induction hypothesis. By computing the *mex* value of each of the two right sets of options and each of the four left sets of options, we always find the value 2. Thus, $\mathcal{G}(S_1 \bullet^2 \bullet S_2) = 2$.

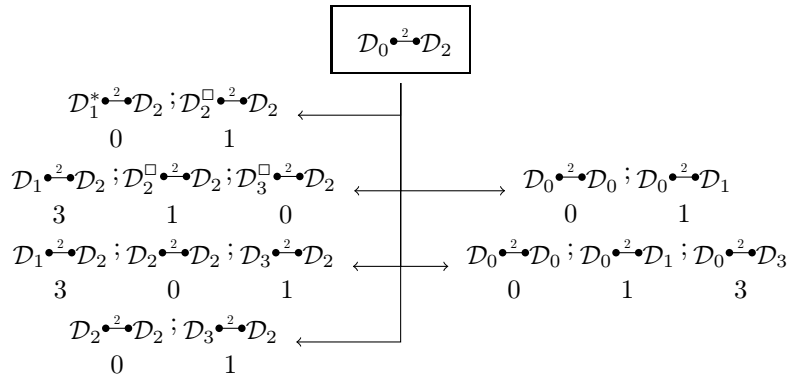

Figure 14: The possible options of $S_1 \bullet^2 \bullet S_2$ when $S_1 \in \mathcal{D}_0$ and $S_2 \in \mathcal{D}_2$.

There is a total of 36 cases to consider. As they are all similar to the two we already considered, we only present the possible classes of the options of S , on Figure 15.

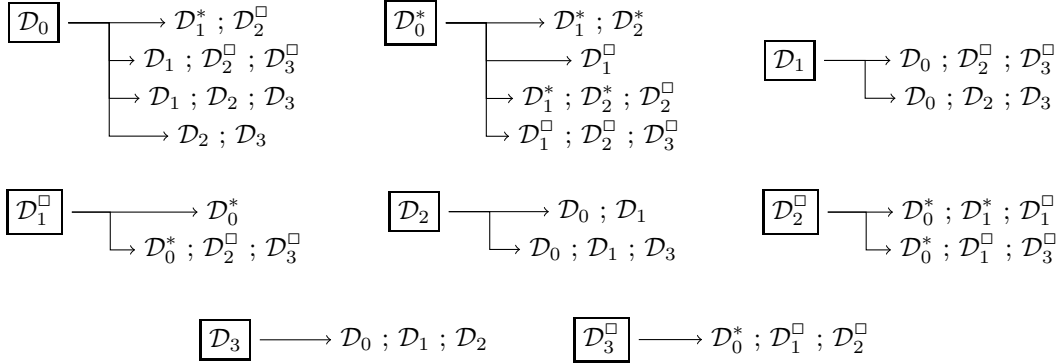

Figure 15: The classes of the possible options of S depending on its class.

Going through all the cases allows to prove the correctness of Table 2. □

This concludes our study of subdivided bistars.

5. Conclusion

In this paper, we provided a general definition of octal games on graphs, capturing some existing take-away games on graphs. We then focused on one of the simplest octal games, **0.33**, on some subclasses of trees, namely subdivided stars and bistars.

We proved that for subdivided stars and bistars, as in paths, one could reduce the length of the paths to their length modulo 3. Thanks to this result, we have computed the exact Grundy values of any subdivided star, and thus exhibited a periodic behaviour. We have extended these results to bistars for which one can also reduce the lengths of any chain modulo 3. Using operators and equivalence classes similar to the nim-sum and Grundy classes, we could then compute the Grundy value of a subdivided bistar using values of the two stars that are composing it.

However, the reduction of paths modulo 3 cannot be generalized to trees:

Observation 22. *One cannot add a P_3 to any vertex of a bistar without changing the Grundy value (and even without changing the output). Indeed, the bistar of Figure 16 is an \mathcal{N} -position, but appending a P_3 to u changes it into a \mathcal{P} -position.*

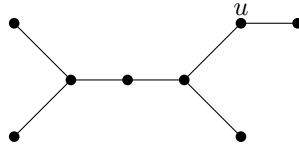

Figure 16: Counter-example for trees: appending a P_3 to u changes the outcome.

Proof. The bistar is an \mathcal{N} -position: removing u and the leaf attached to it leaves $S_{1,1,3}$ which is equivalent to $S_{1,1}$ by Theorem 7, which is a \mathcal{P} -position.

Appending a P_3 to u changes the outcome: by a straightforward case analysis, we can check that every move leaves a \mathcal{N} -position. □

Actually, we conjecture that the Grundy value of trees for the **0.33** game is not even bounded.

Conjecture 23. *For all $n \geq 4$, there exists a tree T such that $\mathcal{G}_{0.33}(T) = n$.*

This conjecture might even be true in the class of caterpillars. A feeble argument to illustrate this intuition comes from our computations. We may provide examples of caterpillars with Grundy values as large as 11. Figure 17 depicts a caterpillar with a Grundy value of 10 (checked by computer).

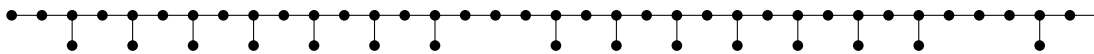

Figure 17: A caterpillar with a Grundy value of 10.

Conjecture 24. *For all $n \geq 4$, there exists a caterpillar H such that $\mathcal{G}_{0.33}(H) = n$.*

However, some of our results could be generalized to other octal games on subdivided stars, see [14].

Finally, we would like to mention that it would certainly be interesting to consider the misère version of the 0.33 game on graphs.

References

- [1] Berkelamp, E. R., Conway, J. H. and Guy, R. K. (2001-2004). *Winning ways for your mathematical plays* (2nd ed., 4 volumes). Wellesley, MA: A K Peters.
- [2] Albert, M., Nowakowski, R. and Wolfe, D. (2007). *Lessons in play: an introduction to combinatorial game theory*. CRC Press.
- [3] Siegel, A. N. (2013). *Combinatorial game theory* (Vol. 146). American Mathematical Soc..
- [4] Guy, R. K. (1996). Unsolved problems in Combinatorial Games. In R. Nowakowski (Ed.), *Games of No Chance*. MSRI Book Series (vol. 29). Cambridge: Cambridge University Press..
- [5] Althöfer, I. and Bülttermann, J. (1995). Superlinear period lengths in some subtraction games. *Theoretical computer science*, 148(1), 111–119. doi:10.1016/0304-3975(95)00019-S
- [6] Fleischer, R. and Trippen, G. (2006). Kayles on the way to the stars. In H. Jaap van den Herik et al. (Eds.), *Computers and Games. 4th International Conference, CG, 2004*. LNCS Book Series (vol. 3846). Berlin Heidelberg: Springer-Verlag. doi:10.1007/11674399_16
- [7] Schaeffer, T. J. (1978). On the complexity of some two-person perfect-information games. *J. Comput. System Sci.*, 16(2), 185–225. doi:10.1016/0022-0000(78)90045-4
- [8] Adams, R., Dixon, J., Elder, J., Peabody, J., Vega, O. and Will, K. (2015). *Combinatorial Analysis of a Subtraction Game on Graphs*. Retrieved from arXiv:1507.05673.
- [9] Fraenkel, A. S., Scheinerman, E. R. and Ullman, D. (1993). Undirected edge geography. *Theoretical Computer Science*, 112(2), 371-381.
- [10] Nowakowski, R. J. and Ottaway, P. (2005). Vertex deletion games with parity rules. *Integers: Electronic Journal of Combinatorial Number Theory*, 5(2), A15.
- [11] Harding, P. and Ottaway, P. (2014). Edge deletion games with parity rules. *Integers*, 14, G1.

- [12] Blanc, L., Duchêne, E. and Gravier, S. (2006). A Deletion Game On Graphs: “Le Pic’arete”. *Integers: Electronic Journal of Combinatorial Number Theory*, 6(G02), G02.
- [13] Huggan, M. (2015). *Impartial Intersection Restriction Games* (master’s thesis). Retrieved from Carleton University Research Virtual Environment (CURVE) (Record b3819898).
- [14] Dailly, A., Moncel, J. and Parreau, A. (2016). *Octal Games on Graphs: The games 0.3^n on subdivided stars*. Unpublished.
- [15] Sprague, R. (1935). Über mathematische Kampfspiele. *Tohoku Mathematical Journal, First Series*, 41, 438–444.
- [16] Duchêne, É., Gravier, S. and Mhalla, M. (2016). *Scoring octal games on tree*. Unpublished.